

1



TOOLKITS



1

TOOLKITS

635 PCS. JUEGOS UNIVERSALES / UNIVERSAL SETS / JEUX UNIVERSELS / UNIVERSELLE SÄTZE / KIT UNIVERSALE / ALGEMENE SETS / JOGOS UNIVERSAIS

NEW



| COD |  | pcs. | |  |
|-------|---|------|---------|---|
| 68960 | - | 635 | | 56 |
| 68961 | 51040 | 636 | mm/inch | 151 |



| Pcs. | Descripción / Description | Composición / Composition |
|------|--|---|
| 20 | alicates circlips pliers | 62214, 62215, 62216, 62217, 62218, 62219, 62220, 62221, 62222, 62223, 62224, 62225, 62226, 62227, 62228, 62229, 62180, 62181, 62182, 62183 |
| 9 | destornilladores mecanicos / screwdrivers slotted | 66400, 66401, 66403, 66405, 66407, 66408, 66409, 66410, 66525 |
| 7 | destornilladores electricistas / screwdrivers electrician | 66429, 66430, 66431, 66432, 66433, 66434, 66435 |
| 5 | destornilladores Philips screwdrivers | 66438, 66439, 66440, 66441, 66442, 66526 |
| 5 | destornilladores Pozidriv screwdrivers | 66456, 66457, 66458, 66459, 66460, 66527 |
| 13 | destornilladores Torx screwdrivers | 66474, 66475, 66476, 66477, 66478, 66479, 66480, 66481, 66482, 66483, 66484, 66485, 66486 |
| 7 | destornilladores T-mastertork screwdrivers | 66571, 66572, 66573, 66574, 66575, 66576, 66577 |
| 16 | set rev. Mastergear | 69870 |
| 13 | llaves de tubo doble boca / socket double ended | 61824, 61825, 61826, 61827, 61828, 61829, 61830, 61831, 61832, 61833, 61834, 61835, 61836 |
| 19 | llaves articuladas en T / T handle wrenches with universal joint | 61840, 61841, 61842, 61843, 61844, 61845, 61846, 61847, 61848, 61849, 61850, 61851, 61852, 61853, 61854, 61855, 61856, 61857, 61858 |
| 32 | llaves combinadas mm / combination wrenches mm | 61725, 61726, 61727, 61728, 61729, 61730, 61731, 61732, 61733, 61734, 61735, 61736, 61737, 61738, 61739, 61740, 61741, 61742, 61743, 61744, 61745, 61746, 61747, 61748, 61749, 61750, 60952, 60953, 60954, 60955, 60956 |
| 23 | llaves combinadas pulg. / combination wrenches inch. | 60340, 60341, 60342, 60343, 60344, 60345, 60346, 60347, 60348, 60349, 60350, 60351, 60352, 60353, 60354, 60355, 60356, 60357, 60358, 60957, 60958, 60959, 60960 |
| 14 | llaves fijas mm / open end wrenches mm | 61701, 61702, 61703, 61704, 61705, 61706, 61707, 61708, 61709, 61710, 61711, 60712, 61713 |
| 15 | llaves fijas pulg. / open end wrenches inch. | 60300, 60301, 60302, 60303, 60304, 60305, 60306, 60307, 60308, 60309, 60310, 60311, 60312, 60313, 60314 |
| 16 | llaves acodadas mm / double offset ring wrenches mm | 61775, 61776, 61777, 61778, 61779, 61780, 61781, 61782, 61783, 61784, 61785, 61786, 61787, 61788, 61789, 61790 |
| 15 | llaves acodadas pulg. / double offset ring wrenches inch. | 60380, 60381, 60382, 60383, 60384, 60385, 60386, 60387, 60388, 60389, 60390, 60391, 60392, 60393, 60394 |
| 25 | Juego 26 pcs mm 1/2" / 26 pcs. socket set 1/2" mm | 61960 |
| 25 | Juego 26 pcs pulg. 1/2" / 26 pcs. socket set 1/2" inch. | 61963 |
| 26 | llaves de pipa / angled sockets | 61870, 61871, 61872, 61873, 61874, 61875, 61876, 61877, 61878, 61879, 61880, 61881, 61882, 61883, 61884, 61885, 61886, 61887, 61888, 61889, 61890, 61891, 61892, 61893, 61894, 61895 |
| 23 | llaves hexagonales mm / hexagonal keys mm | 65302, 65303, 65304, 65305, 65306, 65307, 65308, 65309, 65310, 65311, 65312, 65313, 65314, 61501, 61502, 61503, 61504, 61505, 61506, 61507, 61508, 61509, 61510 |
| 7 | llaves hexagonales pulg. / hexagonal keys inch. | 65315, 65316, 65317, 65318, 65319, 65320, 65321, 65322, 65323, 65324, 65325, 65326, 65327, 65328, 65329 |
| 7 | botadores octogonales / octagonal punches | 63401, 63402, 63403, 63404, 63405, 63406, 63407 |
| 3 | granetes / center punches | 63429, 63430, 63431, 63432, 63433, 63434, 63435 |
| 13 | cortafrios / cold chisel | 63178, 63179, 63180 |
| 9 | alicates / pliers | 62331, 62332, 62333, 62337, 62338, 62339, 62340, 62341, 62342, 62343, 62344, 62345, 62349 |
| 3 | alicates mini pliers | 62241, 62242, 62243, 62244, 62245, 62246, 62247, 62248, 62249 |
| 2 | tenazas de canal / box joint | 62133, 62135, 62134 |
| 5 | llave ajustable / adjustable wrench | 61112, 61114 |
| 1 | extractores / gear pullers | 62586, 62587, 62588, 62589, 62590 |
| 29 | arco de sierra / hack saw | 63748 |
| 29 | juego vasos 1/4" mm socket set | 61958 |
| 1 | juego vasos 1/4" pulg. / 1/4" socket set inch. | 61961 |
| 7 | llave dinamométrica 1/2" 30-210 nm reversible torque wrench | 61209 |
| 32 | martillos / hammers | 69619, 69622, 69614, 69750, 69742, 69729, 69521 |
| 2 | juego puntas / bits set | 66942 |
| 8 | llave HD 12" HD pipe wrench | 61016, 61018 |
| 6 | tenazas grip / grip pliers | 62177, 62178, 62172, 62231, 62486, 62487, 62508, 62490, |
| 1 | limas / files | 63498, 63534, 63570, 63606, 63642, 63678 |
| 1 | tijera de chapa / tin snip | 62233 |
| 1 | tijera electricista snip | 69534 |
| 3 | calibre / caliper | 65479 |
| 3 | sargentos g clamps | 69570, 69572, 69575 |
| 1 | sargentos F clamps | 69582, 69586, 69588 |
| 1 | nivel trapezoidal 400mm bridge type spirit level | 65155 |
| 1 | destornillador portapuntas magnetico bitholder screwdriver | 66731 |
| 10 | juego de vasos impacto mm impact socket sets | 60693 |
| 11 | juego de vasos impacto inch. impact socket sets | 61267 |
| 2 | tenaza rusa 9",10" tower pincer | 62123, 62124 |
| 2 | tenaza carpintero / carpenter pincer | 62438, 62440 |
| 4 | set de pinzas / tweezers set | 69529 |
| 1 | alicate de terminales / crimping pliers | 62493 |
| 11 | llaves de carraca para racores / ratcheting ring wrench | 65089, 65090, 65091, 65092, 65093, 65095, 65096, 65098, 65099, 65100, 65102 |
| 19 | juego destornilladores microtronic screwdriver set | 66846, 66848, 66849, 66850, 66851, 66852, 66853, 66854, 66855, 66856, 66857, 66858, 66859, 66860, 66861, 66862, 66863, 66864, 66865 |
| 1 | Magnetizador-desmagnetizador / magnetizer-demagnetizer | 69504 |
| 1 | flexómetros 3m/10' measuring tape | 65362 |
| 6 | limas de aguja / needle files | 63714, 63715, 63716, 63717, 63718, 63719 |
| 1 | recogedor telescopico / telescopic joint pick up | 65695 |
| 1 | espejo articulado / joint telescopic mirror | 65586 |
| 1 | regla 300mm ruler | 65774 |
| 1 | cortatubos cobre 42 cooper tube cutter | 63119 |
| 1 | rasqueta / scrapper | 63376 |
| 1 | cepillo limpieza cobre / copper cleaner brushes | 63207 |
| 8 | set curvatubos carraca mm ratchet tube bender set | 68172 |
| 1 | abocinador mm / pulg flaring tool | 68091 |
| 1 | cortatubos acero 2" steel tube cutter | 63172 |
| 1 | cortatubos plastico piraina plastic tube cutter | 63205 |
| 14 | formones / firmer chisels | 67169, 67170, 67171, 67172, 67173, 67174, 67175, 67176, 67177, 67178, 67179, 67180, 67181, 67182 |
| 1 | cortavarillas 8" bolt cutters | 62200 |
| 1 | cutter | 69501 |
| 14 | set sierra de coronas / bimetel hole saws set | 64616 |
| 1 | espatula / scrapper | 67022 |
| 1 | tester | 66073 |

1

TOOLKITS

429 PCS. JUEGOS UNIVERSALES / UNIVERSAL SETS / JEUX UNIVERSELS / UNIVERSELLE SÄTZE / KIT UNIVERSALE / ALGEMENE SETS / JOGOS UNIVERSAIS

NEW



| COD | | pcs. | | Kg. |
|-------|-------|------|---------|-----|
| 68962 | - | 429 | mm/inch | 96 |
| 68963 | 51039 | 430 | | 149 |



| Pcs. | Descripción / Description | Composición / Composition |
|------|---|---|
| 20 | alicates circlip pliers | 62214, 62215, 62216, 62217, 62218, 62219, 62220, 62221, 62222, 62223, 62224, 62225, 62226, 62227, 62228, 62229, 62180, 62181, 62182, 62183 |
| 27 | destornilladores mec, electricistas, Philips, Pozidriv screwdrivers | 66400, 66401, 66403, 66405, 66407, 66408, 66409, 66410, 66429, 66430, 66431, 66432, 66433, 66434, 66435, 66438, 66439, 66440, 66441, 66442, 66451, 66452, 66456, 66457, 66458, 66459, 66460 |
| 26 | llaves combinadas mm / combination wrenches mm | 61725, 61726, 61727, 61728, 61729, 61730, 61731, 61732, 61733, 61734, 61735, 61736, 61737, 61738, 61739, 61740, 61741, 61742, 61743, 61744, 61745, 61746, 61747, 61748, 61749, 61750 |
| 17 | llaves combinadas pulg. / combination wrenches inch. | 60340, 60341, 60342, 60343, 60344, 60345, 60346, 60347, 60348, 60349, 60350, 60351, 60352, 60353, 60354, 60355, 60356 |
| 12 | llaves fijas mm / open end wrenches mm | 61701, 61702, 61703, 61704, 61705, 61706, 61707, 61708, 61709, 61710, 61711, 61713 |
| 12 | llaves fijas / open end wrenches inch. | 60300, 60301, 60302, 60303, 60304, 60306, 60309, 60310, 60311, 60312, 60313, 60314 |
| 12 | llaves acodadas mm. / double offset ring wrenches mm | 61775, 61776, 61777, 61778, 61779, 61780, 61781, 61782, 61783, 61784, 61785, 61787 |
| 12 | llaves acodadas pulg. / double offset ring wrenches inch. | 60380, 60381, 60382, 60383, 60384, 60386, 60389, 60390, 60391, 60392, 60393, 60394 |
| 25 | Juego 26 pcs mm 1/2" / 26 pcs. socket set 1/2" mm | 61960 |
| 25 | Juego 26 pcs pulg. 1/2" / 26 pcs. socket set 1/2" inch. | 61963 |
| 26 | llaves de pipa / angled sockets | 61870, 61871, 61872, 61873, 61874, 61875, 61876, 61877, 61878, 61879, 61880, 61881, 61882, 61883, 61884, 61885, 61886, 61887, 61888, 61889, 61890, 61891, 61892, 61893, 61894, 61895 |
| 23 | llaves hexagonales mm / hexagonal keys mm | 65302, 65303, 65304, 65305, 65306, 65307, 65308, 65309, 65310, 65311, 65312, 65313, 65314, 61501, 61502, 61503, 61504, 61505, 61506, 61507, 61508, 61509, 61510 |
| 15 | llaves hexagonales pulg. / hexagonal keys inch. | 65315, 65316, 65317, 65318, 65319, 65320, 65321, 65322, 65323, 65324, 65325, 65326, 65327, 65328, 65329 |
| 7 | botadores octogonales / octogonal punches | 63401, 63402, 63403, 63404, 63405, 63406, 63407 |
| 7 | granetes / center punches | 63429, 63430, 63431, 63432, 63433, 63434, 63435 |
| 3 | cortafrios / cold chisel | 63178, 63179, 63180 |
| 10 | alicates / pliers | 62331, 62332, 62477, 62339, 62340, 62341, 62342, 62343, 62344, 62349 |
| 9 | alicates mini pliers | 62241, 62242, 62243, 62244, 62245, 62246, 62247, 62248, 62249 |
| 2 | tenazas de canal / box joint | 62135, 62134 |
| 1 | llave ajustable / adjustable wrench | 61112 |
| 2 | extractores / gear pullers | 62587, 62590 |
| 1 | arco de sierra / hack saw | 63748 |
| 1 | llave dinamométrica 1/2" 30-210 nm reversible torque wrench | 61209 |
| 7 | martillos / hammers | 69619, 69622, 69614, 69750, 69742, 69729, 69521 |
| 32 | juego puntas / bits set | 66942 |
| 1 | llave HD 12" HD pipe wrench | 61016 |
| 3 | tenazas grip / grip pliers | 62177, 62178, 62172 |
| 6 | limas / files | 63498, 63534, 63570, 63606, 63642, 63678 |
| 1 | tijera de chapa / tin snip | 62233 |
| 1 | tijera electricista snip | 69534 |
| 1 | calibre / caliper | 65479 |
| 3 | sargentos g clamps | 69570, 69572, 69575 |
| 1 | nivel trapezoidal 400mm bridge type spirit level | 65155 |
| 1 | destornillador portapuntas magnetico bitholder screwdriver | 66731 |
| 10 | juego de vasos impacto mm impact socket sets | 60693 |
| 11 | juego de vasos impacto inch. impact socket sets | 61267 |
| 1 | tenaza rusa 10" tower pincer | 62124 |
| 2 | tenaza carpintero / carpenter pincer | 62438, 62440 |
| 4 | set de pinzas / tweezers set | 69529 |
| 1 | alicate de terminales / crimping pliers | 62493 |
| 12 | juego destornilladores microtronic screwdriver set | 66846, 66848, 66849, 66850, 66851, 66852, 66853, 66854, 66862, 66863, 66864, 66865 |
| 1 | Magnetizador-desmagnetizador / magnetizer-demagnetizer | 69504 |
| 1 | flexómetros 3m/10' measuring tape | 65362 |
| 6 | limas de aguja / needle files | 63714, 63715, 63716, 63717, 63718, 63719 |
| 1 | recogedor telescopico / telescopic joint pick up | 65595 |
| 1 | espejo articulado / joint telescopic mirror | 65586 |
| 1 | regla 300mm ruler | 65774 |
| 1 | cortatubos cobre 42 cooper tube cutter | 63119 |
| 1 | rasqueta / scrapper | 63376 |
| 1 | cepillo limpieza cobre / copper cleaner brushes | 63207 |
| 8 | set curvatubos carraca mm ratchet tube bender set | 68172 |
| 1 | abocinador mm-pulg. / pulg flaring tool mm.-inch | 68091 |
| 1 | cortatubos acero 2" steel tube cutter | 63172 |
| 1 | cortatubos plastico piraina plastic tube cutter | 63205 |
| 1 | cortavarillas 8" bolt cutters | 62200 |
| 1 | cutter | 69501 |
| 9 | set sierra de coronas / bimetal hole saws set | 64615 |
| 1 | tester | 66073 |

189 PCS. JUEGOS UNIVERSALES / UNIVERSAL SETS / JEUX UNIVERSELS / UNIVERSELLE SÄTZE / KIT UNIVERSALE / ALGEMENE SETS / JOGOS UNIVERSAIS



| COD | | pcs. | | Hg. |
|-------|-------|------|---------|-----|
| 68964 | - | 189 | | 39 |
| 68965 | 51025 | 190 | mm/inch | 92 |

| Pcs. | Descripción / Description | Composición / Composition |
|------|---|--|
| 16 | alicates circlip pliers | 62214, 62215, 62216, 62217, 62218, 62219, 62220, 62221, 62222, 62223, 62224, 62225, 62226, 62227, 62228, 62229 |
| 18 | destornilladores mec, electricistas, Philips, Pozidriv screwdrivers | 66400, 66401, 66403, 66407, 66408, 66430, 66431, 66432, 66433, 66434, 66439, 66440, 66441, 66451, 66452, 66457, 66458, 66459 |
| 12 | llaves combinadas mm combination wrenches | 61725, 61726, 61727, 61728, 61729, 61730, 61731, 61732, 61733, 61734, 61735, 61736 |
| 12 | llaves combinadas inch. combination wrenches | 60341, 60342, 60343, 60344, 60345, 60347, 60348, 60349, 60351, 60352, 60353, 60354 |
| 8 | llaves fijas mm / open end wrenches mm | 61701, 61702, 61703, 61704, 61705, 61706, 61707, 61708 |
| 8 | llaves fijas pulg. / open end wrenches inch. | 60302, 60303, 60304, 60306, 60309, 60310, 60311, 60312 |
| 8 | llaves acodadas mm. / double offset ring wrenches mm | 61775, 61776, 61777, 61778, 61779, 61780, 61781, 61782 |
| 8 | llaves acodadas pulg. / double offset ring wrenches inch. | 60382, 60383, 60384, 60385, 60386, 60389, 60390, 60391 |
| 16 | juego llaves vaso 1/2" mm socket wrench set | 61796 |
| 16 | juego llaves vaso 1/2" inch. socket wrench set | 61798 |
| 10 | llaves hexagonales mm hexagonal keys | 61503, 61504, 61505, 61506, 61508, 61509, 61510, 65307, 65308, 65310 |
| 10 | llaves hexagonales pulg. / hexagonal keys inch. | 65318, 65319, 65320, 65321, 65322, 65323, 65324, 65325, 65326, 65327 |
| 5 | botadores / punches | 63402, 63403, 63404, 63405, 63406 |
| 2 | cortafrios / cold chisel | 63178, 63179 |
| 4 | alicates / pliers | 62340, 62343, 62344, 62349 |
| 1 | tenazas de canal / box joint | 62135 |
| 1 | llave ajustable / adjustable wrench | 61112 |
| 2 | extractores / gear pullers | 62587, 62590 |
| 1 | arco de sierra / hack saw | 63748 |
| 4 | martillos / hammers | 69619, 69622, 69614, 69750 |
| 1 | llave HD 12" HD pipe wrench | 61016 |
| 3 | tenazas grip / grip pliers | 62177, 62178, 62172 |
| 6 | limas / files | 63498, 63534, 63570, 63606, 63642, 63678 |
| 1 | tijera de chapa / tin snip | 62233 |
| 1 | tijera electricista / electrician scissors | 69534 |
| 1 | calibre / caliper | 65479 |
| 1 | sargentos g clamps | 69572 |
| 1 | tenaza rusa 10" tower pincer | 62124 |
| 2 | tenaza carpintero / carpenter pincer | 62438, 62440 |
| 4 | set de pinzas / tweezers set | 69529 |
| 1 | alicate de terminales / crimping pliers | 62493 |
| 1 | flexómetros 3m/10' measuring tape | 65362 |
| 1 | recogedor telescopico / telescopic joint pick up | 65595 |
| 1 | cortatubos cobre 42 cooper tube cutter | 63119 |
| 1 | cutter | 69501 |
| 1 | tester | 66073 |

299 PCS. JUEGOS MANTENIMIENTO INDUSTRIAL / INDUSTRIAL MAINTENANCE SETS / JEUX DE MAINTENANCE INDUSTRIELLE / INDUSTRIELLE WARTUNG SÄTZE / KIT MANUTENZIONE INDUSTRIALE INDUSTRIËLE ONDERHOUDSSET / JOGOS DE MANUTENÇÃO INDUSTRIAL

NEW



| COD | | pcs. | | Mg. |
|-------|-------|------|----|-----|
| 68966 | - | 299 | mm | 52 |
| 68967 | 51039 | 300 | | 105 |

| Pcs. | Descripción / Description | Composición / Composition |
|------|---|---|
| 20 | alicates circlip pliers | 62214, 62215, 62216, 62217, 62218, 62219, 62220, 62221, 62222, 62223, 62224, 62225, 62226, 62227, 62228, 62229, 62180, 62181, 62182, 62183 |
| 27 | destornilladores mec, electricistas, Philips, Pozidriv screwdrivers | 66400, 66401, 66403, 66405, 66407, 66408, 66409, 66410, 66429, 66430, 66431, 66432, 66433, 66434, 66435, 66438, 66439, 66440, 66441, 66442, 66451, 66452, 66456, 66457, 66458, 66459, 66460 |
| 26 | llaves combinadas / combination wrenches | 61725, 61726, 61727, 61728, 61729, 61730, 61731, 61732, 61733, 61734, 61735, 61736, 61737, 61738, 61739, 61740, 61741, 61742, 61743, 61744, 61745, 61746, 61747, 61748, 61749, 61750 |
| 12 | llaves fijas / open end wrenches | 61701, 61702, 61703, 61704, 61705, 61706, 61707, 61708, 61709, 61710, 61711, 61713 |
| 12 | llaves acodadas / double offset ring wrenches | 61775, 61776, 61777, 61778, 61779, 61780, 61781, 61782, 61783, 61784, 61785, 61787 |
| 25 | Juego 26 pcs mm 1/2" / 26 pcs. socket set 1/2" mm | 61960 |
| 12 | llaves de pipa / angled sockets | 61872, 61874, 61875, 61877, 61878, 61881, 61883, 61886, 61888, 61891, 61894, 61895 |
| 14 | llaves hexagonales mm hexagonal keys | 61501, 61502, 61503, 61504, 61505, 61506, 61508, 61509, 61510, 65307, 65308, 65310, 65311, 65313 |
| 7 | botadores / punches | 63401, 63402, 63403, 63404, 63405, 63406, 63407 |
| 2 | cortafrios / cold chisel | 63178, 63179 |
| 10 | alicates / pliers | 62331, 62332, 62477, 62339, 62340, 62341, 62342, 62343, 62344, 62349 |
| 2 | tenazas de canal / box joint | 62135, 62134 |
| 1 | llave ajustable / adjustable wrench | 61112 |
| 2 | extractores / gear pullers | 62587, 62590 |
| 1 | arco de sierra / hack saw | 63748 |
| 29 | juego vasos 1/4" metrica socket set | 61958 |
| 1 | llave dinamométrica 1/2" 30-210 nm reversible torque wrench | 61209 |
| 4 | martillos / hammers | 69619, 69622, 69614, 69750 |
| 32 | juego puntas / bits set | 66942 |
| 1 | llave HD 12" HD pipe wrench | 61016 |
| 3 | tenazas grip / grip pliers | 62177, 62178, 62172 |
| 6 | limas / files | 63498, 63534, 63570, 63606, 63642, 63678 |
| 1 | tijera de chapal/ tin snip | 62233 |
| 1 | tijera electricista / electrician scissors | 69534 |
| 1 | calibre / caliper | 65479 |
| 2 | sargentos g clamps | 69571, 69574 |
| 1 | nivel trapezoidal 400mm bridge type spirit level | 65155 |
| 1 | destornillador portapuntas magnetico bitholder screwdriver | 66731 |
| 10 | juego de vasos impacto / impact socket sets | 60693 |
| 1 | tenaza rusa 10" tower pincer | 62124 |
| 4 | set de pinzas / tweezers set | 69529 |
| 1 | alicate de terminales / crimping pliers | 62493 |
| 11 | llaves de carraca para racores / ratcheting ring wrench | 65089, 65090, 65091, 65092, 65093, 65095, 65096, 65098, 65099, 65100, 65102 |
| 6 | juego destornilladores microtronic screwdriver set | 66999 |
| 1 | flexometro 3 m measuring tape | 65168 |
| 6 | limas de aguja / needle files | 63714, 63715, 63716, 63717, 63718, 63719 |
| 1 | recogedor telescopico / telescopic joint pick up | 65595 |
| 1 | espejo articulado / joint telescopic mirror | 65586 |
| 1 | regla 300mm ruler | 65774 |

284 PCS. JUEGOS MANTENIMIENTO INDUSTRIAL / INDUSTRIAL MAINTENANCE SETS / JEUX DE MAINTENANCE INDUSTRIELLE / INDUSTRIELLE WARTUNG SÄTZE / KIT MANUTENZIONE INDUSTRIALE INDUSTRIËLE ONDERHOUDSSET / JOGOS DE MANUTENÇÃO INDUSTRIAL

NEW

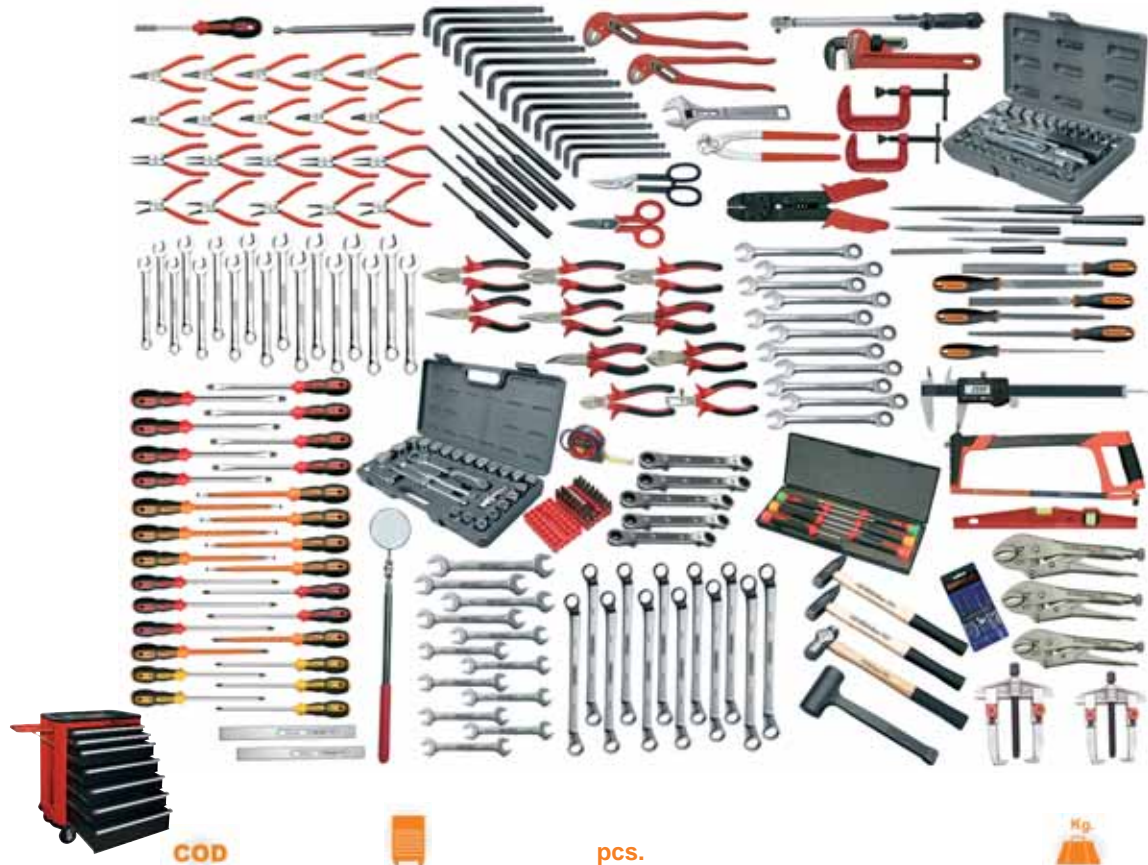

| COD | | pcs. | | Kg. |
|-------|-------|------|------|-----|
| 68968 | - | 284 | | 47 |
| 68969 | 51039 | 285 | inch | 100 |

| Pcs. | Descripción / Description | Composición / Composition |
|------|---|---|
| 20 | alicates circlips pliers | 62214, 62215, 62216, 62217, 62218, 62219, 62220, 62221, 62222, 62223, 62224, 62225, 62226, 62227, 62228, 62229, 62180, 62181, 62182, 62183 |
| 27 | destornilladores mec, electricistas, Philips, Pozidriv screwdrivers | 66400, 66401, 66403, 66405, 66407, 66408, 66409, 66410, 66429, 66430, 66431, 66432, 66433, 66434, 66435, 66438, 66439, 66440, 66441, 66442, 66451, 66452, 66456, 66457, 66458, 66459, 66460 |
| 17 | llaves combinadas / combination wrenches | 60340, 60341, 60342, 60343, 60344, 60345, 60346, 60347, 60348, 60349, 60350, 60351, 60352, 60353, 60354, 60355, 60356 |
| 12 | llaves fijas / open end wrenches | 60300, 60301, 60302, 60303, 60304, 60306, 60309, 60310, 60311, 60312, 60313, 60314 |
| 12 | llaves acodadas / double offset ring wrenches | 60380, 60381, 60382, 60383, 60384, 60386, 60389, 60390, 60391, 60392, 60393, 60394 |
| 25 | Juego 26 pcs pulg, 1/2" / 26 pcs. socket set 1/2" inch. | 61963 |
| 5 | llaves de estrella carraca / ratchet wrench | 65113, 65114, 65115, 65116, 65117 |
| 15 | llaves hexagonales inch. hexagonal keys | 65315, 65316, 65317, 65318, 65319, 65320, 65321, 65322, 65323, 65324, 65325, 65326, 65327, 65328, 65329 |
| 7 | botadores / punches | 63401, 63402, 63403, 63404, 63405, 63406, 63407 |
| 2 | cortafrios / cold chisel | 63178, 63179 |
| 10 | alicates / pliers | 62331, 62332, 62477, 62339, 62340, 62341, 62342, 62343, 62344, 62349 |
| 2 | tenazas de canal / box joint | 62135, 62134 |
| 1 | llave ajustable / adjustable wrench | 61112 |
| 2 | extractores / gear pullers | 62587, 62590 |
| 1 | arco de sierra / hack saw | 63748 |
| 29 | juego vasos 1/4" inch. socket set | 61961 |
| 1 | llave dinamométrica 1/2" 20-150lb-ft reversible torque wrench | 61209 |
| 4 | martillos / hammers | 69619, 69622, 69614, 69750 |
| 32 | juego puntas / bits set | 66942 |
| 1 | llave HD 12" HD pipe wrench | 61016 |
| 3 | tenazas grip / grip pliers | 62177, 62178, 62172 |
| 6 | limas / files | 63498, 63534, 63570, 63606, 63642, 63678 |
| 1 | tijera de chapa / tin snip | 62233 |
| 1 | tijera electricista / electrician scissors | 69534 |
| 1 | calibre / caliper | 65485 |
| 2 | sargentos g clamps | 69571, 69574 |
| 1 | nivel trapezoidal 400mm bridge type spirit level | 65155 |
| 1 | destornillador portapuntas magnetico bitholder screwdriver | 66731 |
| 10 | juego de vasos impacto inch. impact socket sets | 61267 |
| 1 | tenaza rusa 10" tower pincer | 62124 |
| 4 | set de pinzas / tweezers set | 69529 |
| 1 | alicate de terminales / crimping pliers | 62493 |
| 11 | Mastergear wrench | 62666, 62667, 62668, 62669, 62670, 62671, 62672, 62673, 62674, 62675, 62676 |
| 6 | juego destornilladores microtronic screwdriver set | 66999 |
| 1 | flexometro 3 m (mm/inch) measuring tape | 65172 |
| 6 | limas de aguja / needle files | 63714, 63715, 63716, 63717, 63718, 63719 |
| 1 | recogedor telescopico / telescopic joint pick up | 65595 |
| 1 | espejo articulado / joint telescopic mirror | 65586 |
| 1 | regla 300mm ruler | 65773 |

152 PCS. JUEGOS MANTENIMIENTO INDUSTRIAL / INDUSTRIAL MAINTENANCE SETS / JEUX DE MAINTENANCE INDUSTRIELLE / INDUSTRIELLE WARTUNG SÄTZE / KIT MANUTENZIONE INDUSTRIALE INDUSTRIËLE ONDERHOUDSSET / JOGOS DE MANUTENÇÃO INDUSTRIAL



| COD | | pcs. | | Hg. |
|-------|-------|------|----|-----|
| 68970 | - | 152 | mm | 35 |
| 68971 | 51025 | 153 | | 88 |

| Pcs. | Descripción / Description | Composición / Composition |
|------|---|--|
| 16 | alicates circlips pliers | 62214, 62215, 62216, 62217, 62218, 62219, 62220, 62221, 62222, 62223, 62224, 62225, 62226, 62227, 62228, 62229 |
| 18 | destornilladores mec, electricistas, Philips, Pozidriv screwdrivers | 66400, 66401, 66403, 66407, 66408, 66430, 66431, 66432, 66433, 66434, 66439, 66440, 66441, 66451, 66452, 66457, 66458, 66459 |
| 12 | llaves combinadas / combination wrenches | 61725, 61726, 61727, 61728, 61729, 61730, 61731, 61732, 61733, 61734, 61735, 61736 |
| 8 | llaves fijas / open end wrenches | 61701, 61702, 61703, 61704, 61705, 61706, 61707, 61708 |
| 8 | llaves acodadas / double offset ring wrenches | 61775, 61776, 61777, 61778, 61779, 61780, 61781, 61782 |
| 25 | Juego 26 pcs mm 1/2" / 26 pcs. socket set 1/2" mm | 61960 |
| 10 | llaves hexagonales mm hexagonal keys | 61503, 61504, 61505, 61506, 61508, 61509, 61510, 65307, 65308, 65310 |
| 5 | botadores / punches | 63402, 63403, 63404, 63405, 63406 |
| 2 | cortafrios / cold chisel | 63178, 63179 |
| 6 | alicates / pliers | 62332, 62340, 62342, 62343, 62344, 62349 |
| 1 | tenazas de canal / box joint | 62135 |
| 1 | llave ajustable / adjustable wrench | 61112 |
| 2 | extractores / gear pullers | 62587, 62590 |
| 1 | arco de sierra / hack saw | 63748 |
| 1 | llave dinamométrica 1/2" 30-210 nm reversible torque wrench | 61209 |
| 4 | martillos / hammers | 69619, 69622, 69614, 69750 |
| 1 | llave HD 12" HD pipe wrench | 61016 |
| 3 | tenazas grip / grip pliers | 62177, 62178, 62172 |
| 6 | limas / files | 63498, 63534, 63570, 63606, 63642, 63678 |
| 1 | tijera de chapa / tin snip | 62233 |
| 1 | tijera electricista / electrician scissors | 69534 |
| 1 | calibre / caliper | 65479 |
| 2 | sargentos g clamps | 69571, 69574 |
| 1 | nivel trapezoidal 400mm bridge type spirit level | 65155 |
| 1 | tenaza rusa 10" tower pincer | 62124 |
| 4 | set de pinzas / tweezers set | 69529 |
| 1 | alicate de terminales / crimping pliers | 62493 |
| 1 | flexometro 3 m measuring tape | 65168 |
| 6 | limas de aguja / needle files | 63714, 63715, 63716, 63717, 63718, 63719 |
| 1 | recogedor telescópico / telescopic joint pick up | 65595 |
| 1 | espejo articulado / joint telescopic mirror | 65586 |
| 1 | regla 300mm ruler | 65774 |

152 PCS. JUEGOS MANTENIMIENTO INDUSTRIAL / INDUSTRIAL MAINTENANCE SETS / JEUX DE MAINTENANCE INDUSTRIELLE / INDUSTRIELLE WARTUNG SÄTZE / KIT MANUTENZIONE INDUSTRIALE INDUSTRIËLE ONDERHOUDSSET / JOGOS DE MANUTENÇÃO INDUSTRIAL

NEW



| COD | | pcs. | | Kg. |
|-------|-------|------|------|-----|
| 68972 | - | 152 | | 33 |
| 68973 | 51025 | 153 | inch | 86 |

| Pcs. | Descripción / Description | Composición / Composition |
|------|---|--|
| 16 | alicates circlips pliers | 62214, 62215, 62216, 62217, 62218, 62219, 62220, 62221, 62222, 62223, 62224, 62225, 62226, 62227, 62228, 62229 |
| 18 | destornilladores mec, electricistas, Philips, Pozidriv screwdrivers | 66400, 66401, 66403, 66407, 66408, 66430, 66431, 66432, 66433, 66434, 66439, 66440, 66441, 66451, 66452, 66457, 66458, 66459 |
| 12 | llaves combinadas / combination wrenches | 60341, 60342, 60343, 60344, 60345, 60347, 60348, 60349, 60351, 60352, 60353, 60354 |
| 8 | llaves fijas / open end wrenches | 60302, 60303, 60304, 60306, 60309, 60310, 60311, 60312 |
| 8 | llaves acodadas / double offset ring wrenches | 60382, 60383, 60384, 60385, 60386, 60389, 60390, 60391 |
| 25 | Juego 26 pcs pulg. 1/2" / 26 pcs. socket set 1/2" inch. | 61963 |
| 10 | llaves hexagonales pulg. / hexagonal keys inch. | 65318, 65319, 65320, 65321, 65322, 65323, 65324, 65325, 65326, 65327 |
| 5 | botadores / punches | 63402, 63403, 63404, 63405, 63406 |
| 2 | cortafrios / cold chisel | 63178, 63179 |
| 6 | alicates / pliers | 62332, 62340, 62342, 62343, 62344, 62349 |
| 1 | tenazas de canal / box joint | 62135 |
| 1 | llave ajustable / adjustable wrench | 61112 |
| 2 | extractores / gear pullers | 62587, 62590 |
| 1 | arco de sierra / hack saw | 63748 |
| 1 | llave dinamométrica 1/2" 20-150 lb-ft reversible torque wrench | 61209 |
| 4 | martillos / hammers | 69619, 69622, 69614, 69750 |
| 1 | llave HD 12" HD pipe wrench | 61016 |
| 3 | tenazas grip / grip pliers | 62177, 62178, 62172 |
| 6 | limas / files | 63498, 63534, 63570, 63606, 63642, 63678 |
| 1 | tijera de chapa / tin snip | 62233 |
| 1 | tijera electricista / electrician scissors | 69534 |
| 1 | calibre / caliper | 65485 |
| 2 | sargentos g clamps | 69571, 69574 |
| 1 | nivel trapezoidal 400mm bridge type spirit level | 65155 |
| 1 | tenaza rusa 10" tower pincer | 62124 |
| 4 | set de pinzas / tweezers set | 69529 |
| 1 | alicate de terminales / crimping pliers | 62493 |
| 1 | flexometro 3 m (mm/inch) measuring tape | 65172 |
| 6 | limas de aguja / needle files | 63714, 63715, 63716, 63717, 63718, 63719 |
| 1 | recogedor telescópico / telescopic joint pick up | 65595 |
| 1 | espejo articulado / joint telescopic mirror | 65586 |
| 1 | regla 300mm ruler | 65773 |

1 TOOLKITS



158 PCS. JUEGO AERONAUTICA / AVIATION SET / JEU AERONAUTIQUE / WERKZEUGSET FÜR LUFTFAHRT / KIT PER AEREONAUTICA / GEREEDSCHAPSSET VOOR DE LUCHTVAART / JOGO AERONÁUTICA

NEW



| COD | | pcs. | | Kg. |
|-------|-------|------|------|-----|
| 68974 | - | 158 | | 21 |
| 68975 | 51039 | 159 | inch | 74 |

| Pcs. | Descripción / Description | Composición / Composition |
|------|--|---|
| 10 | botadores / punches | 63380, 63381, 63382, 63401, 63402, 63403, 63404, 63405, 63406, 63407 |
| 6 | limas / files | 63498, 63534, 63570, 63606, 63642, 63678 |
| 3 | cortafrios / cold chisel | 63178, 63179, 63180 |
| 12 | destornilladores Rotork screwdrivers | 66874, 66875, 66877, 66880, 66883, 66885, 66897, 66898, 66899, 66938, 66901, 66902, |
| 1 | calibre / caliper | 65479 |
| 1 | llave ajustable / adjustable wrench | 61112 |
| 1 | tenazas de canal / box joint | 62135 |
| 11 | set dinamométrica / reversible torque wrench set | 61226 |
| 4 | alicates / pliers | 62333, 62343, 62337, 62339 |
| 11 | llaves de Mastergear SPLINE Mastergear wrenches | 62695, 62696, 62697, 62698, 62699, 62700, 62701, 62702, 62703, 62704, 62705 |
| 15 | llaves acodadas / double offset ring wrenches | 60380, 60381, 60382, 60383, 60384, 60385, 60386, 60387, 60388, 60389, 60390, 60391, 60392, 60393, 60394 |
| 14 | llaves combinadas / combination wrenches | 60341, 60342, 60343, 60344, 60345, 60346, 60347, 60348, 60349, 60350, 60351, 60352, 60353, 60354 |
| 33 | juego de vasos 1/2" socket set | 61963 |
| 1 | arco de sierra / hack saw | 63748 |
| 12 | llaves hexagonales / hexagonal keys | 65315, 65316, 65317, 65318, 65319, 65320, 65321, 65322, 65323, 65324, 65325 |
| 1 | cutter | 69501 |
| 1 | flexómetros 3m/10' measuring tape | 65362 |
| 2 | martillos / hammers | 69619, 69544 |
| 1 | recogedor telescópico / telescopic joint pick up | 65595 |
| 1 | galga de espesores / feeler gauge | 65550 |
| 6 | limas de aguja / needle files | 63714, 63715, 63716, 63717, 63718, 63719 |
| 4 | set de pinzas / tweezers set | 69529 |
| 1 | tijera electricista / electrician scissors | 69534 |
| 3 | tenazas grip / grip pliers | 62178 |
| 1 | espejo articulado / joint telescopic mirror | 65586 |
| 1 | tijera aviación articulada reforzada / reinforced aviation tin snips | 62188 |
| 1 | tenaza de sifon / syphon plier | 62136 |



1

TOOLKITS

418 PCS. JUEGOS MECANICA / SETS FOR MECHANICS / JEUX DE MÉCANICIENS / WERKZEUGSÄTZE FÜR MECHANIKER / KIT MECCANICA / WERKTUIGSET / JOGO DE MECÂNICA

NEW



| COD |  | pcs. | |  |
|-------|---|------|----|---|
| 68976 | - | 418 | | 110 |
| 68977 | 51040 | 419 | mm | 205 |



| Pcs. | Descripción / Description | Composición / Composition |
|------|--|--|
| 20 | alicates circlip pliers | 62214, 62215, 62216, 62217, 62218, 62219, 62220, 62221, 62222, 62223, 62224, 62225, 62226, 62227, 62228, 62229, 62180, 62181, 62182, 62183 |
| 9 | destornilladores mecanicos / screwdrivers slotted | 66400, 66401, 66403, 66405, 66407, 66408, 66409, 66410, 66525 |
| 7 | destornilladores electricistas / screwdrivers electrician | 66429, 66430, 66431, 66432, 66433, 66434, 66435 |
| 5 | destornilladores Philips screwdrivers | 66438, 66439, 66440, 66441, 66442, 66526 |
| 5 | destornilladores Pozidriv screwdrivers | 66456, 66457, 66458, 66459, 66460, 66527 |
| 13 | destornilladores Torx screwdrivers | 66474, 66475, 66476, 66477, 66478, 66479, 66480, 66481, 66482, 66483, 66484, 66485, 66486 |
| 7 | destornilladores T-mastertork screwdrivers | 66571, 66572, 66573, 66574, 66575, 66576, 66577 |
| 16 | set rev. Mastergear | 69870 |
| 13 | llaves de tubo doble boca / socket double ended | 61824, 61825, 61826, 61827, 61828, 61829, 61830, 61831, 61832, 61833, 61834, 61835, 61836 |
| 19 | llaves articuladas en "T" handle wrenches with universal joint | 61840, 61841, 61842, 61843, 61844, 61845, 61846, 61847, 61848, 61849, 61850, 61851, 61852, 61853, 61854, 61855, 61856, 61857, 61858 |
| 32 | llaves combinadas mm combination wrenches | 61725, 61726, 61727, 61728, 61729, 61730, 61731, 61732, 61733, 61734, 61735, 61736, 61737, 61738, 61739, 61740, 61741, 61742, 61743, 61744, 61745, 61746, 61747, 61748, 61749, 61750, 60951, 60952, 60953, 60954, 60955, 60956 |
| 14 | llaves fijas mm / open end wrenches mm | 61701, 61702, 61703, 61704, 61705, 61706, 61700, 61707, 61708, 61709, 61710, 61711, 61712, 61713 |
| 16 | llaves acodadas mm / double offset ring wrenches mm | 61775, 61776, 61777, 61778, 61779, 61780, 61781, 61782, 61783, 61784, 61785, 61786, 61787, 61788, 61789, 61790 |
| 25 | Juego 26 pcs mm 1/2" / 26 pcs. socket set 1/2" mm | 61960 |
| 26 | llaves de pipa / angled sockets | 61870, 61871, 61872, 61873, 61874, 61875, 61876, 61877, 61878, 61879, 61880, 61881, 61882, 61883, 61884, 61885, 61886, 61887, 61888, 61889, 61890, 61891, 61892, 61893, 61894, 61895 |
| 23 | llaves hexagonales mm / hexagonal keys mm | 65302, 65303, 65304, 65305, 65306, 65307, 65308, 65309, 65310, 65311, 65312, 65313, 65314, 61501, 61502, 61503, 61504, 61505, 61506, 61507, 61508, 61509, 61510 |
| 7 | botadores octogonales / octagonal punches | 63401, 63402, 63403, 63404, 63405, 63406, 63407 |
| 7 | granetes / center punches | 63429, 63430, 63431, 63432, 63433, 63434, 63435 |
| 3 | cortafrios / cold chisel | 63178, 63179, 63180 |
| 13 | alicates / pliers | 62331, 62332, 62333, 62337, 62338, 62339, 62340, 62341, 62342, 62343, 62344, 62345, 62349 |
| 3 | tenazas de canal / box joint | 62133, 62135, 62134 |
| 2 | llave ajustable / adjustable wrench | 61112, 61114 |
| 5 | extractores / gear pullers | 62586, 62587, 62588, 62589, 62590 |
| 1 | arco de sierra / hack saw | 63748 |
| 29 | juego vasos 1/4" mm socket set | 61958 |
| 1 | llave dinamoétrica 1/2" 30-210 nm reversible torque wrench | 61209 |
| 7 | martillos / hammers | 69619, 69622, 69614, 69750, 69742, 69729, 69521 |
| 32 | juego puntas / bits set | 66942 |
| 1 | llave HD 12" HD pipe wrench | 61016 |
| 3 | tenazas grip / grip pliers | 62177, 62178, 62172 |
| 6 | limas / files | 63498, 63534, 63570, 63606, 63642, 63678 |
| 1 | tijera de chapa / tin snip | 62233 |
| 1 | tijera electricista / electrician scissors | 69534 |
| 1 | calibre / caliper | 65479 |
| 1 | nivel trapezoidal 400mm bridge type spirit level | 65155 |
| 1 | destornillador portapuntas magnetico bitholder screwdriver | 66731 |
| 10 | juego de vasos impacto mm. / impact socket sets mm | 60693 |
| 4 | set de pinzas / tweezers set | 69529 |
| 1 | alicate de terminales / crimping pliers | 62493 |
| 11 | llaves de carraca para racores / ratcheting ring wrench | 65089, 65090, 65091, 65092, 65093, 65095, 65096, 65098, 65099, 65100, 65102 |
| 1 | Magnetizador-desmagnetizador / magnetizer-demagnetizer | 69504 |
| 1 | flexometro 3 m (mm/inch) measuring tape | 65362 |
| 6 | limas de aguja / needle files | 63714, 63715, 63716, 63717, 63718, 63719 |
| 1 | recogedor telescopico / telescopic joint pick up | 65695 |
| 1 | espejo articulado / joint telescopic mirror | 65586 |
| 1 | regla 300mm ruler | 65774 |
| 1 | cortatubos cobre 42 cooper tube cutter | 63119 |
| 1 | cortatubos acero 2" steel tube cutter | 63172 |
| 1 | cortatubos plastico piraina plastic tube cutter | 63205 |
| 1 | cutter | 69501 |
| 1 | multimetro / multimeter | 65506 |
| 1 | navaja / penknife | 69527 |



1

TOOLKITS

335 PCS. JUEGOS MECANICA / SETS FOR MECHANICS / JEUX DE MÉCANICIENS / WERKZEUGSÄTZE FÜR MECHANIKER / KIT MECCANICA / WERKTUIGSET / JOGO DE MECÂNICA

NEW



| COD |  | pcs. |  |
|-------|---|------|---|
| 68978 | - | 335 | 71 |
| 68979 | 51040 | 336 | 166 |



| Pcs. | Descripción / Description | Composición / Composition |
|------|---|---|
| 20 | alicates circlip pliers | 62214, 62215, 62216, 62217, 62218, 62219, 62220, 62221, 62222, 62223, 62224, 62225, 62226, 62227, 62228, 62229, 62180, 62181, 62182, 62183 |
| 9 | destornilladores mecanicos / screwdrivers slotted | 66400, 66401, 66403, 66405, 66407, 66408, 66409, 66410, 66525 |
| 7 | destornilladores electricistas / screwdrivers electrician | 66429, 66430, 66431, 66432, 66433, 66434, 66435 |
| 5 | destornilladores Philips screwdrivers | 66438, 66439, 66440, 66441, 66442, 66526 |
| 5 | destornilladores Pozidriv screwdrivers | 66456, 66457, 66458, 66459, 66460, 66527 |
| 13 | destornilladores Torx screwdrivers | 66474, 66475, 66476, 66477, 66478, 66479, 66480, 66481, 66482, 66483, 66484, 66485, 66486 |
| 7 | destornilladores T-mastertork screwdrivers | 66571, 66572, 66573, 66574, 66575, 66576, 66577 |
| 19 | llaves articuladas en "T" handle wrenches with universal joint | 61840, 61841, 61842, 61843, 61844, 61845, 61846, 61847, 61848, 61849, 61850, 61851, 61852, 61853, 61854, 61855, 61856, 61857, 61858 |
| 23 | llaves combinadas inch. combination wrenches | 60340, 60341, 60342, 60343, 60344, 60345, 60346, 60347, 60348, 60349, 60350, 60351, 60352, 60353, 60354, 60355, 60356, 60357, 60358, 60957, 60958, 60959, 60960 |
| 15 | llaves fijas inch. open end wrenches | 60300, 60301, 60302, 60303, 60304, 60305, 60306, 60307, 60308, 60309, 60310, 60311, 60312, 60313, 60314 |
| 15 | llaves acodadas inch. double offset ring wrenches | 60380, 60381, 60382, 60383, 60384, 60385, 60386, 60387, 60388, 60389, 60390, 60391, 60392, 60393, 60394 |
| 25 | llaves de vaso 1/2", extensiones 5" y 10", carraca, mango corredizo en T, articulacion universal (inch.)1/2" socket wrench, 5"-10" extensions, ratchet, sliding T handle, universal joint | 61963 |
| 15 | llaves hexagonales inch. hexagonal keys | 65315, 65316, 65317, 65318, 65319, 65320, 65321, 65322, 65323, 65324, 65325, 65326, 65327, 65328, 65329 |
| 7 | botadores octogonales / octagonal punches | 63401, 63402, 63403, 63404, 63405, 63406, 63407 |
| 7 | granetes / center punches | 63429, 63430, 63431, 63432, 63433, 63434, 63435 |
| 3 | cortafrios / cold chisel | 63178, 63179, 63180 |
| 13 | alicates / pliers | 62331, 62332, 62333, 62337, 62338, 62339, 62340, 62341, 62342, 62343, 62344, 62345, 62349 |
| 3 | tenazas de canal / box joint | 62133, 62135, 62134 |
| 2 | llave ajustable / adjustable wrench | 61112, 61114 |
| 5 | extractores / gear pullers | 62586, 62587, 62588, 62589, 62590 |
| 1 | arco de sierra / hack saw | 63748 |
| 29 | juego vasos 1/4" pulg. / socket set 1/4" inch. | 61961 |
| 1 | llave dinamométrica 1/2" 30-210 nm reversible torque wrench | 61209 |
| 7 | martillos / hammers | 69619, 69622, 69614, 69750, 69742, 69729, 69521 |
| 32 | juego puntas / bits set | 66942 |
| 1 | llave HD 12" HD pipe wrench | 61016 |
| 3 | tenazas grip / grip pliers | 62177, 62178, 62172 |
| 6 | limas / files | 63498, 63534, 63570, 63606, 63642, 63678 |
| 1 | tijera de chapa / tin snip | 62233 |
| 1 | tijera electricista / electrician scissors | 69534 |
| 1 | calibre / caliper | 65479 |
| 1 | nivel trapezoidal 400mm bridge type spirit level | 65155 |
| 1 | destornillador portapuntas magnetico bitholder screwdriver | 66731 |
| 11 | juego de vasos impacto pulg. / impact socket sets inch. | 61267 |
| 4 | set de pinzas / tweezers set | 69529 |
| 1 | alicate de terminales pliers | 62493 |
| 1 | Magnetizador-desmagnetizador / magnetizer-demagnetizer | 69504 |
| 1 | flexómetros 3m/10' measuring tape | 65362 |
| 6 | limas de aguja / needle files | 63714, 63715, 63716, 63717, 63718, 63719 |
| 1 | recogedor telescopico / telescopic joint pick up | 65695 |
| 1 | espejo articulado / joint telescopic mirror | 65586 |
| 1 | regla 300mm ruler | 65774 |
| 1 | cortatubos cobre 42 cooper tube cutter | 63119 |
| 1 | cortatubos acero 2" steel tube cutter | 63172 |
| 1 | cortatubos plastico piraina plastic tube cutter | 63205 |
| 1 | cutter | 69501 |
| 1 | multimetro / multimeter | 65506 |
| 1 | navaja / penknife | 69527 |

227 PCS. JUEGOS MECANICA / SETS FOR MECHANICS / JEUX DE MÉCANICIENS / WERKZEUGSÄTZE FÜR MECHANIKER / KIT MECCANICA / WERKTUIGSET / JOGO DE MECÂNICA

NEW



| COD | | pcs. | | Kg. |
|-------|-------|------|----|-----|
| 68980 | - | 227 | mm | 42 |
| 68981 | 51025 | 228 | | 95 |

| Pcs. | Descripción / Description | Composición / Composition |
|------|---|--|
| 16 | alicates circlip pliers | 62214, 62215, 62216, 62217, 62218, 62219, 62220, 62221, 62222, 62223, 62224, 62225, 62226, 62227, 62228, 62229 |
| 18 | destornilladores mec, electricistas, Philips, Pozidriv screwdrivers | 66400, 66401, 66403, 66407, 66408, 66430, 66431, 66432, 66433, 66434, 66439, 66440, 66441, 66451, 66452, 66457, 66458, 66459 |
| 13 | destornilladores Torx screwdrivers | 66474, 66475, 66476, 66477, 66478, 66479, 66480, 66481, 66482, 66483, 66484, 66485, 66486 |
| 7 | destornilladores T-mastertork screwdrivers | 66571, 66572, 66573, 66574, 66575, 66576, 66577 |
| 13 | llaves de tubo doble boca / socket double ended | 61824, 61825, 61826, 61827, 61828, 61829, 61830, 61831, 61832, 61833, 61834, 61835, 61836 |
| 12 | llaves combinadas mm combination wrenches | 61725, 61726, 61727, 61728, 61729, 61730, 61731, 61732, 61733, 61734, 61735, 61736 |
| 8 | llaves fijas / open end wrenches | 61701, 61702, 61703, 61704, 61705, 61706, 61707, 61708 |
| 8 | llaves acodadas / double offset ring wrenches | 61775, 61776, 61777, 61778, 61779, 61780, 61781, 61782 |
| 16 | juego llaves vaso 1/2" mm socket set | 61796 |
| 10 | llaves hexagonales mm hexagonal keys | 61503, 61504, 61505, 61506, 61508, 61509, 61510, 65307, 65308, 65310 |
| 7 | botadores octogonales / octagonal punches | 63401, 63402, 63403, 63404, 63405, 63406, 63407 |
| 7 | granetes / center punches | 63429, 63430, 63431, 63432, 63433, 63434, 63435 |
| 3 | cortafrios / cold chisel | 63178, 63179, 63180 |
| 6 | alicates / pliers | 62332, 62340, 62342, 62343, 62344, 62349 |
| 1 | tenazas de canal / box joint | 62135 |
| 1 | llave ajustable / adjustable wrench | 61112 |
| 2 | extractores / gear pullers | 62587, 62590 |
| 1 | arco de sierra / hack saw | 63748 |
| 1 | llave dinamométrica 1/2" 30-210 nm reversible torque wrench | 61209 |
| 7 | martillos / hammers | 69619, 69622, 69614, 69750, 69742, 69729, 69521 |
| 32 | juego puntas / bits set | 66942 |
| 1 | llave HD 12" HD pipe wrench | 61016 |
| 3 | tenazas grip / grip pliers | 62177, 62178, 62172 |
| 6 | limas / files | 63498, 63534, 63570, 63606, 63642, 63678 |
| 1 | tijera de chapa / tin snip | 62233 |
| 1 | tijera electricista / electrician scissors | 69534 |
| 1 | calibre / caliper | 65479 |
| 1 | nivel trapezoidal 400mm bridge type spirit level | 65155 |
| 1 | destornillador portapuntas magnetico bitholder screwdriver | 66731 |
| 10 | juego de vasos impacto mm impact socket sets | 60693 |
| 4 | set de pinzas / tweezers set | 69529 |
| 1 | alicate de terminales / crimping pliers | 62493 |
| 1 | Magnetizador-desmagnetizador / magnetizer-demagnetizer | 69504 |
| 1 | flexómetros 3m/10' measuring tape | 65362 |
| 1 | recogedor telescopico / telescopic joint pick up | 65595 |
| 1 | espejo articulado / joint telescopic mirror | 65586 |
| 1 | regla 300mm ruler | 65774 |
| 1 | cortatubos plastico piraina plastic tube cutter | 63205 |
| 1 | cutter | 69501 |
| 1 | navaja / penknife | 69527 |

1 TOOLKITS



214 PCS. JUEGOS MECANICA / SETS FOR MECHANICS / JEUX DE MÉCANICIENS / WERKZEUGSÄTZE FÜR MECHANIKER / KIT MECCANICA / WERKTUIGSET / JOGO DE MECÂNICA

NEW



| COD | | pcs. | | Kg |
|-------|-------|------|------|----|
| 68982 | - | 214 | inch | 37 |
| 68983 | 51025 | 215 | | 90 |

| Pcs. | Descripción / Description | Composición / Composition |
|------|---|--|
| 16 | alicates circlip pliers | 62214, 62215, 62216, 62217, 62218, 62219, 62220, 62221, 62222, 62223, 62224, 62225, 62226, 62227, 62228, 62229 |
| 18 | destornilladores mec, electricistas, Philips, Pozidriv screwdrivers | 66400, 66401, 66403, 66407, 66408, 66430, 66431, 66432, 66433, 66434, 66439, 66440, 66441, 66451, 66452, 66457, 66458, 66459 |
| 13 | destornilladores Torx screwdrivers | 66474, 66475, 66476, 66477, 66478, 66479, 66480, 66481, 66482, 66483, 66484, 66485, 66486 |
| 7 | destornilladores T-mastertork screwdrivers | 66571, 66572, 66573, 66574, 66575, 66576, 66577 |
| 12 | llaves combinadas / combination wrenches | 60341, 60342, 60343, 60344, 60345, 60347, 60348, 60349, 60351, 60352, 60353, 60354 |
| 8 | llaves fijas / open end wrenches | 60302, 60303, 60304, 60306, 60309, 60310, 60311, 60312 |
| 8 | llaves acodadas / double offset ring wrenches | 60382, 60383, 60384, 60385, 60386, 60389, 60390, 60391 |
| 16 | juego llaves vaso 1/2" inch. socket set | 61798 |
| 10 | llaves hexagonales inch. hexagonal keys | 65318, 65319, 65320, 65321, 65322, 65323, 65324, 65325, 65326, 65327 |
| 7 | botadores octogonales / octogonal punches | 63401, 63402, 63403, 63404, 63405, 63406, 63407 |
| 7 | granetes / center punches | 63429, 63430, 63431, 63432, 63433, 63434, 63435 |
| 3 | cortafrios / cold chisel | 63178, 63179, 63180 |
| 6 | alicates / pliers | 62332, 62340, 62342, 62343, 62344, 62349 |
| 1 | tenazas de canal / box joint | 62135 |
| 1 | llave ajustable / adjustable wrench | 61112 |
| 2 | extractores / gear pullers | 62587, 62590 |
| 1 | arco de sierra / hack saw | 63748 |
| 1 | llave dinamométrica 1/2" 30-210 nm reversible torque wrench | 61209 |
| 7 | martillos / hammers | 69619, 69622, 69614, 69750, 69742, 69729, 69521 |
| 32 | juego puntas / bits set | 66942 |
| 1 | llave HD 12" HD pipe wrench | 61016 |
| 3 | tenazas grip / grip pliers | 62177, 62178, 62172 |
| 6 | limas / files | 63498, 63534, 63570, 63606, 63642, 63678 |
| 1 | tijera de chapa / tin snip | 62233 |
| 1 | tijera electricista / electrician scissors | 69534 |
| 1 | calibre / caliper | 65479 |
| 1 | nivel trapezoidal 400mm bridge type spirit level | 65155 |
| 1 | destornillador portapuntas magnetico bitholder screwdriver | 66731 |
| 11 | juego de vasos impacto / impact socket sets | 61267 |
| 4 | set de pinzas / tweezers set | 69529 |
| 1 | alicate de terminales / crimping pliers | 62493 |
| 1 | Magnetizador-desmagnetizador / magnetizer-demagnetizer | 69504 |
| 1 | flexómetros 3m/10' measuring tape | 65362 |
| 1 | recogedor telescopico / telescopic joint pick up | 65595 |
| 1 | espejo articulado / joint telescopic mirror | 65586 |
| 1 | regla 300mm ruler | 65774 |
| 1 | cortatubos plastico piraina plastic tube cutter | 63205 |
| 1 | cutter | 69501 |
| 1 | navaja / penknife | 69527 |

NATO Commercial and Government Entity (NCAGE) Code / Código (NCAGE) OTAN: 8552B

108 PCS. JUEGOS MECANICA / SETS FOR MECHANICS / JEUX DE MÉCANICIENS / WERKZEUGSÄTZE FÜR MECHANIKER / KIT MECCANICA / WERKTUIGSET / JOGO DE MECÂNICA

NEW



| Pcs. | Descripción / Description | Composición / Composition |
|------|---|--|
| 8 | alicates circlip pliers | 62214, 62215, 62216, 62217, 62222, 62223, 62224, 62225 |
| 11 | destornilladores mec, electricistas, Philips, Pozidriv screwdrivers | 66400, 66401, 66403, 66407, 66408, 66439, 66440, 66441, 66457, 66458, 66459 |
| 10 | destornilladores Torx screwdrivers | 66475, 66476, 66477, 66478, 66479, 66480, 66481, 66482, 66483, 66484 |
| 12 | llaves combinadas mm combination wrenches | 61725, 61726, 61727, 61728, 61729, 61730, 61731, 61732, 61733, 61734, 61735, 61736 |
| 8 | llaves fijas / open end wrenches | 61701, 61702, 61703, 61704, 61705, 61706, 61707, 61708 |
| 8 | llaves acodadas / double offset ring wrenches | 61775, 61776, 61777, 61778, 61779, 61780, 61781, 61782 |
| 16 | juego llaves vaso 1/2" mm socket set | 61796 |
| 10 | llaves hexagonales / hexagonal keys | 61503, 61504, 61505, 61506, 61508, 61509, 61510, 65307, 65308, 65310 |
| 3 | botadores / punches | 63402, 63404, 63406 |
| 1 | cortafrios / cold chisel | 63179 |
| 4 | alicates / pliers | 62332, 62343, 62344, 62349 |
| 1 | tenazas de canal / box joint | 62135 |
| 1 | llave ajustable / adjustable wrench | 61112 |
| 2 | extractores / gear pullers | 62587, 62590 |
| 1 | llave dinamométrica 1/2" 30-210 nm reversible torque wrench | 61209 |
| 4 | martillos / hammers | 69619, 69622, 69614, 69750 |
| 1 | tenazas grip pliers | 62178 |
| 3 | limas / files | 63498, 63570, 63678 |
| 1 | tijera de chapa / tin snip | 62233 |
| 1 | flexómetros 3m/10' measuring tape | 65362 |
| 1 | recogedor telescópico / telescopic joint pick up | 65595 |
| 1 | cutter | 69501 |

1 TOOLKITS

108 PCS. JUEGOS MECANICA / SETS FOR MECHANICS / JEUX DE MÉCANICIENS / WERKZEUGSÄTZE FÜR MECHANIKER / KIT MECCANICA / WERKTUIGSET / JOGO DE MECÂNICA



| COD | | pcs. | | Kg. |
|-------|-------|------|-------|-----|
| 68986 | - | 108 | inch. | 27 |
| 68987 | 51024 | 109 | | 67 |

| Pcs. | Descripción / Description | Composición / Composition |
|------|---|--|
| 8 | alicates circlip pliers | 62214, 62215, 62216, 62217, 62222, 62223, 62224, 62225 |
| 11 | destornilladores mec, electricistas, Philips, Pozidriv screwdrivers | 66400, 66401, 66403, 66407, 66408, 66439, 66440, 66441, 66457, 66458, 66459 |
| 10 | destornilladores Torx screwdrivers | 66475, 66476, 66477, 66478, 66479, 66480, 66481, 66482, 66483, 66484 |
| 12 | llaves combinadas / combination wrenches | 60341, 60342, 60343, 60344, 60345, 60347, 60348, 60349, 60351, 60352, 60353, 60354 |
| 8 | llaves fijas / open end wrenches | 60302, 60303, 60304, 60306, 60309, 60310, 60311, 60312 |
| 8 | llaves acodadas / double offset ring wrenches | 60382, 60383, 60384, 60385, 60386, 60389, 60390, 60391 |
| 16 | juego llaves vaso 1/2" pulg. / socket set 1/2" inch. | 61798 |
| 10 | llaves hexagonales / hexagonal keys | 65318, 65319, 65320, 65321, 65322, 65323, 65324, 65325, 65326, 65327 |
| 3 | botadores / punches | 63402, 63404, 63406 |
| 1 | cortafrios / cold chisel | 63179 |
| 4 | alicates / pliers | 62332, 62343, 62344, 62349 |
| 1 | tenazas de canal / box joint | 62135 |
| 1 | llave ajustable / adjustable wrench | 61112 |
| 2 | extractores / gear pullers | 62587, 62590 |
| 1 | llave dinamométrica 1/2" 30-210 nm reversible torque wrench | 61209 |
| 4 | martillos / hammers | 69619, 69622, 69614, 69750 |
| 1 | tenazas grip pliers | 62178 |
| 3 | limas / files | 63498, 63570, 63678 |
| 1 | tijera de chapa / tin snip | 62233 |
| 1 | flexómetros 3m/10' measuring tape | 65362 |
| 1 | recogedor telescopico / telescopic joint pick up | 65595 |
| 1 | cutter | 69501 |

1

TOOLKITS

52 PCS. JUEGOS MECANICA / SETS FOR MECHANICS / JEUX DE MÉCANICIENS / WERKZEUGSÄTZE FÜR MECHANIKER / KIT MECCANICA / WERKTUIGSET / JOGO DE MECÂNICA



| COD | | pcs. | | Kg. |
|-------|-------|------|----|-----|
| 68988 | - | 52 | | 8 |
| 68989 | 51011 | 53 | mm | 33 |

| Pcs. | Descripción / Description | Composición / Composition |
|------|---|--|
| 1 | alicate circlip plier | 62213 |
| 7 | destornilladores mec, electricistas, Philips, Pozidriv screwdrivers | 66401, 66403, 66407, 66439, 66440, 66457, 66458 |
| 12 | llaves combinadas / combination wrenches | 61725, 61726, 61727, 61728, 61729, 61730, 61731, 61732, 61733, 61734, 61735, 61736 |
| 16 | juego llaves vaso 1/2" mm socket set | 61796 |
| 7 | llaves hexagonales / hexagonal keys | 61504, 61505, 61506, 61508, 61509, 61510, 65307 |
| 1 | llave dinamométrica 1/2" 30-210 nm reversible torque wrench | 61209 |
| 3 | alicates / pliers | 62332, 62343, 62344 |
| 1 | tenazas de canal / box joint | 62135 |
| 1 | llave ajustable / adjustable wrench | 61112 |
| 2 | martillos / hammers | 69622, 69614 |
| 1 | tijera electricista / electrician scissors | 69534 |

| COD | | pcs. | | Kg. |
|-------|-------|------|------|-----|
| 68990 | - | 52 | | 9 |
| 68991 | 51011 | 53 | inch | 34 |

| Pcs. | Descripción / Description | Composición / Composition |
|------|---|--|
| 1 | alicate circlip plier | 62213 |
| 7 | destornilladores mec, electricistas, Philips, Pozidriv screwdrivers | 66400, 66401, 66403, 66407, 66408, 66439, 66440, 66441, 66457, 66458, 66459 |
| 12 | llaves combinadas / combination wrenches | 60341, 60342, 60343, 60344, 60345, 60347, 60348, 60349, 60351, 60352, 60353, 60354 |
| 16 | juego llaves vaso 1/2" socket set | 61798 |
| 7 | llaves hexagonales / hexagonal keys | 65320, 65321, 65322, 65323, 65324, 65325, 65326 |
| 1 | llave dinamométrica 1/2" 30-210 nm reversible torque wrench | 61209 |
| 3 | alicates / pliers | 62332, 62343, 62344 |
| 1 | tenazas de canal / box joint | 62135 |
| 1 | llave ajustable / adjustable wrench | 61112 |
| 2 | martillos / hammers | 69622, 69614 |
| 1 | tijera electricista / electrician scissors | 69534 |

1 TOOLKITS



JUEGOS MECANICA / SETS FOR MECHANICS / JEUX DE MÉCANICIENS / WERKZEUGSÄTZE FÜR MECHANIKER / KIT MECCANICA / WERKTUIGSET / JOGO DE MECÂNICA

| COD | |
|-------|--|
| 61112 | Llave ajustable 10" Unique Plus Titacrom Adjustable wrench |
| 62497 | Alicate universal Mastercut 200mm Combination pliers |
| 62499 | Alicate telefonista Mastercut 200mm Long nose pliers |
| 62343 | Alicate corte diagonal 160mm Diagonal cutting pliers |
| 61496 | Set allen punta bola / Long pattern ballpoint allen set |
| 66401 | Destornillador mecánico 4x100 Slotted screwdriver |
| 66403 | Destornillador mecánico 5,5x125 Slotted screwdriver |
| 66405 | Destornillador mecánico 6,5x150 Slotted screwdriver |
| 66406 | Destornillador mecánico 8x150 Slotted screwdriver |
| 66439 | Destornillador Philips PH1 Screwdriver |
| 66440 | Destornillador Philips PH2 Screwdriver |
| 66457 | Destornillador Pozidriv PZ1 Screwdriver |
| 66458 | Destornillador Pozidriv PZ2 Screwdriver |
| 69613 | Martillo de bola 425grs. Ball pein hammer |
| 63327 | Cinzel 16x250 Flat chisel |
| 63300 | Arco de Sierra / Hack saw |
| 63179 | Cortafíos 20x200 Cold chisel |
| 51013 | Bolsa portaherramientas / Tool bag |



| | | |
|-------------------------------|----|---|
| 81900 | 26 | JUEGO DE 26 UN 1/2" SET |
| 61725 - 61750 | 26 | LLAVES COMBINADAS 6 -32 COMBINATION WRENCHES |
| 61870 - 61895 | 26 | LLAVES DE PIPA 6-32 ANGLED OPEN SOCKETS |
| 61500 | 10 | JUEGO LLAVES ALLEN 1.5/2/2.5/3/4/5.5/6/8/10 HEXAGONAL KEYS WRENCHES SET |
| 61110 | 1 | LLAVE AJUSTABLE 6" UNIQUE PLUS ADJUSTABLE WRENCH |
| 61935 | 1 | LLAVE AJUSTABLE ALAVESA COMBI 12" UNIQUE PLUS BASQUE WRENCH COMBI |
| 66877/66878/66879/66881/66882 | 5 | DESTORNILLADORES MECANICO ROTORK SLOTTED SCREWDRIVERS |
| 66998/66999/66990 | 3 | DESTORNILLADORES PHILIPS ROTORK PHILIPS SCREWDRIVERS |
| 66908/66909/66910 | 3 | DESTORNILLADORES POZIDRIV ROTORK POZIDRIV SCREWDRIVERS |
| 66921/66923/66926 | 3 | DESTORNILLADORES TORX ROTORK TORX SCREWDRIVERS |
| 62332 | 1 | ALICATE UNIVERSAL TITACROM COMBINATION PLIERS |
| 62340 | 1 | ALICATE TELEFONISTA TITACROM LONG NOSE PLIERS PLIERS |
| 62342 | 1 | ALICATE TELEFONISTA BICURVA TITACROM BENT NOSE PLIERS |
| 62344 | 1 | CORTAALAMBRES REFORZADO / HEAVY DUTY CUTTING NIPPERS |
| 62128 | 1 | TENAZA CANAL / BOX JOINT PLIERS |
| 62172 | 1 | TENAZA GRIP CURVE CURVED GRIP PLIERS |
| 62348 | 1 | ALICATE PELACABLES WIRESTRIPPER |
| 62216 | 1 | ALICATE CIRCLIPS EXTERIOR RECTO / EXTERNAL STRAIGHT CIRCLIPS PLIERS |
| 62220 | 1 | ALICATE CIRCLIPS EXTERIOR CURVO / EXTERNAL BENT CIRCLIPS PLIERS |
| 62224 | 1 | ALICATE CIRCLIPS INTERIOR RECTO / INTERNAL STRAIGHT CIRCLIPS PLIERS |
| 62228 | 1 | ALICATE CIRCLIPS INTERIOR CURVO / INTERNAL BENT CIRCLIPS PLIERS |
| 63300 | 1 | ARCO DE SIERRA HACK SAW |
| 64435 | 10 | HOJA DE SIERRA 24 DIENTES ACERO AL CARBONO / CARBON STEEL HACKSAW BLADE |
| 69621 | 1 | MARTELO ALEMAN / MACHINIST HAMMER |
| 69616 | 1 | MARTILLO DE BOLA / BALL PEIN HAMMER |
| 69544 | 1 | MARTILLO DE NYLON HAMMER |
| 61017 | 1 | LLAVE HEAVY DUTY 14" HEAVY DUTY PIPE WRENCH |
| 61035 | 1 | LLAVE DE CADENA REVERSIBLE CHAIN PIPE WRENCH |
| 61480 | 1 | LLAVE DECORREA / STRAP WRENCH |
| 63119 | 1 | CORTATUBOS UNIQUE 42 TUBE CUTTER |
| 60003 | 1 | ABOCINADOR / FLARING TOOL |
| 62131 | 1 | TENAZA CORTACABLES / CABLE CUTTER |
| 69501 | 1 | CUTTER |
| 51011 | 1 | COFRE / TOOL CHEST |



| | | |
|---|----|--|
| 81900 | 26 | JUEGO DE 26 UN 1/2" SET |
| 61701/61702/61703/61704/61705/61706/61707/61708/61709/61710/61711/61712/61713 | 13 | LLAVES FUJAS 6-7/8-8/10-11/12-13/14-15/16-17/18-19/20-22/21-23/24-26/25-28/27-29/30-32 |
| 69274 | 12 | JUEGO LLAVES COMBINADAS 6/7/8/9/10/11/12/13/14/15/16/17/COMBINATION WRENCHES SET |
| 61000 | 10 | JUEGO LLAVES ALLEN 1.5/2/2.5/3/4/5.5/6/8/10 HEXAGONAL KEYS WRENCHES SET |
| 61110/61113 | 2 | LLAVES AJUSTABLES 6"/12" UNIQUE ADJUSTABLE WRENCHES |
| 66877/66878/66879/66881/66882 | 5 | DESTORNILLADORES MECANICO ROTORK SLOTTED SCREWDRIVER |
| 66898/66899/66900 | 3 | DESTORNILLADORES PHILIPS ROTORK PHILIPS SCREWDRIVER |
| 66908/66909/66910 | 3 | DESTORNILLADORES POZIDRIV ROTORK POZIDRIV SCREWDRIVERS |
| 66921/66923/66926 | 3 | DESTORNILLADORES TORX ROTORK TORX SCREWDRIVERS |
| 66937/66938/66939 | 3 | DESTORNILLADORES CARROCERO ROTORK STUBBY |
| 62332 | 1 | ALICATE UNIVERSAL TITACROM BIMAT COMBINATION PLIERS |
| 62337 | 1 | ALICATE BIPLANA TITACROM BIMAT FLAT NOSE PLIERS |
| 62338 | 1 | ALICATE BREDONDA TITACROM BIMAT ROUND NOSE PLIERS |
| 62341 | 1 | ALICATE TELEFONISTA BICURVA TITACROM BIMAT BENT NOSE PLIERS |
| 62343 | 1 | ALICATE C/DIAGONAL TITACROM BIMAT CUTTING PLIERS |
| 62445 | 1 | TENAZA PICO LORO BIMAT GROOVE JOINT |
| 62231 | 1 | TENAZA GRIP RECTA STRAIGHT GRIP PLIERS |
| 62183 | 1 | ALICATE CIRCLIPS EXTERIOR RECTO / EXTERNAL STRAIGHT CIRCLIPS PLIERS |
| 64182 | 1 | ALICATE CIRCLIPS EXTERIOR CURVO / EXTERNAL BENT CIRCLIPS PLIERS |
| 62181 | 1 | ALICATE CIRCLIPS INTERIOR RECTO / INTERNAL STRAIGHT CIRCLIPS PLIERS |
| 62180 | 1 | ALICATE CIRCLIPS INTERIOR CURVO / INTERNAL BENT CIRCLIPS PLIERS |
| 63300 | 1 | ARCO DE SIERRA - HACK SAW |
| 64435 | 10 | HOJAS DE SIERRA 24 DIENTES ACERO AL CARBONO / CARBON STEEL HACKSAW BLADE |
| 69924 | 1 | MARTILLO EBANISTA / JOINERS HAMMER |
| 69544 | 1 | MARTILLO DE NYLON HAMMER |
| 61012 | 1 | MALETA / CASE |



1

TOOLKITS

47 PCS. JUEGOS HIDRAULICA / SET FOR HYDRAULICS / JEUX HYDRAULIQUES / WERKZEUGSÄTZE FÜR HYDRAULIK / KIT IDRAULICA / HYDRAULISCHE WERKTUIGSET / JOGOS HIDRÁULICA



NEW



| COD | | pcs. | Kg. |
|-------|-------|------|-----|
| 68992 | - | 47 | 16 |
| 68993 | 51011 | 48 | 41 |

| Pcs. | Descripción / Description | Composición / Composition |
|------|---|-----------------------------------|
| 12 | juego llaves fijas 6x7, 8x9, 10x11, 12x13, 14x15, 16x17, 18x19, 20x22, 21x23, 24x27, 25x28, 30x32 open end wrenches set | 69247 |
| 2 | cortafrios 160 - 200 cold chisel | 63178, 63179 |
| 1 | llave ajustable 10" adjustable wrench | 61112 |
| 1 | cortatubos acero 2" steel tube cutter | 63172 |
| 1 | cortatubos de cobre unique 42 copper | 63119 |
| 1 | llave stillson 14" stillson wrench | 61004 |
| 1 | llave blitz 175 wrench | 61465 |
| 1 | tenaza de canal 10" box joint | 62133 |
| 1 | tijera para chapa 12" tin snip | 62233 |
| 1 | tenaza grip boca curva 10" curved jaw grip plier | 62172 |
| 1 | tijera electricista / electrician's scissors | 69534 |
| 1 | alicate universal titacrom 180 universal plier | 62333 |
| 5 | destornilladores mastertork 3x80, 4x100, 5.5x125, 6.5x150 y 8x200 screwdrivers | 66400, 66401, 66403, 66405, 66407 |
| 2 | destornilladores mastertork PH1- PH2 screwdrivers | 66439, 66440 |
| 1 | martillo mecanico aleman 300g german type machinist's hammer | 69619 |
| 1 | flexometro 3m/16mm chrome measuring tape | 65168 |
| 1 | lima media cana entrefina 8" medium half round file | 63570 |
| 1 | lima redonda entrefina 8" medium round file | 63678 |
| 1 | nivel trapezoidal 400mm bridge type spirit level | 65293 |
| 1 | arco de sierra / hack saw | 63748 |
| 1 | abocinador mm flaring tool | 68003 |
| 1 | llave de correa 450mm strap wrench | 61480 |
| 8 | set curvatubos carraca mm ratchet tube bender set | 68172 |

1 TOOLKITS



JUEGOS FONTANERIA Y AIRE ACONDICIONADO / PLUMBING AND CONDITIONED AIR SETS / JEUX PLOMBERIE ET AIR CONDITIONNEE / WERKZEUGSÄTZE FÜR KLEMPNER UND LÜFTUNG / KIT PER IDRAULICA E CONDIZIONAMENTO / GEREEDSCHAPSSET VOOR LOODGIETER EN AIRCONDITIONING / JOGOS DE CANALIZAÇÃO E AR CONDICIONADO

| COD | |
|-------|---|
| 61934 | Llave ajustable 10" alavesa combi / 10" Combi adjustable wrench |
| 61017 | Llave Heavy Duty 14" Pipe wrench |
| 63172 | Cortatubos acero 2" Steel pipe cutter |
| 62497 | Alicate universal Mastercut 200mm Combination pliers |
| 62499 | Alicate telefonista Mastercut 200mm Long nose pliers |
| 62343 | Alicate corte diagonal 160mm Diagonal cutting pliers |
| 61496 | Set allen punta bola / Long patern ballpoint allen set |
| 66401 | Destornillador mecánico 4x100 Slotted screwdriver |
| 66403 | Destornillador mecánico 5,5x125 Slotted screwdriver |
| 66405 | Destornillador mecánico 6,5x150 Slotted screwdriver |
| 66406 | Destornillador mecánico 8x150 Slotted screwdriver |
| 66439 | Destornillador Philips PH1 Screwdriver |
| 66440 | Destornillador Philips PH2 Screwdriver |
| 63119 | Cortatubos unique-42 Tube cutter |
| 63300 | Arco de Sierra / Hack saw |
| 51013 | Bolsa portaherramientas / Tool bag |



| COD | PCS. | Kg |
|-------|------|-----|
| 69537 | 16 | 7,8 |

| | | |
|---|----|--|
| 61701/61702/61703/61704/61705/61706/61707/61708/61709/61710/61711/61712/61713 | 13 | LLAVES FUJAS 6-7/8-9/10-11/12-13/14-15/16-17/18-19/20-22/21-23/24-26/25-28/27-29/30-32 OPEN END WRENCHES SET |
| 69336 | 10 | JUEGO DE LLAVES ACODADAS 6-7/8-9/10-11/12-13/14-15/16-17/18-19/20-22/21-23/24-26 DOUBLE OFFSET WRENCHES SET |
| 61113 | 1 | LLAVE AJUSTABLE 12" UNIQUE TITACROM ADJUSTABLE WRENCH |
| 61998 | 29 | JUEGO DE 29 UN 1/4" SET |
| 61325/61306 | 2 | LLAVES DE VASO DE DOBLE ARTICULACION 18-17/18-19 DOUBLE ENDED SWIVEL |
| 61500 | 10 | JUEGO LLAVES ALLEN 1,5/2/2,5/3/4/5/5,5/6/8/10 HEXAGONAL KEYS WRENCHES SET |
| 66874/66876/66878/66880/66881 | 5 | DESTORNILLADORES MECANICOS ROTORK SLOTTED SCREWDRIVERS |
| 66893/66895/66896 | 3 | DESTORNILLADORES VARILLA PROTEGIDA ROTORK INSULATED SCREWDRIVERS |
| 66903/66904/66905 | 3 | D. VARILLA PROTEGIDA PHILIPS ROTORK PHILIP INSULATED SCREWDRIVERS |
| 66913/66914/66915 | 3 | D. VARILLA PROT. POZDRIV ROTORK POZDRIV INSULATED SCREWDRIVERS |
| 66920/66921/66922/66923 | 4 | DESTORNILLADORES TORX MICROTRONIC TORX SCREWDRIVERS |
| 66937/66938/66939 | 3 | DESTORNILLADORES CARROCCERO ROTORK STUBBY SCREWDRIVERS |
| 66071 | 1 | DESTORNILLADOR BUSCAPOLOS / VOLTAGE TESTER SCREWDRIVER |
| 61011 | 1 | LLAVE SUECA S-45° /SWEDISH PIPE WRENCH S-45° |
| 61035 | 1 | LLAVE DE CADENA REVERSIBLE CHAIN PIPE WRENCH |
| 63195 | 1 | CORTATUBOS TELESCOPIC 32 TUBE CUTTER |
| 68052 | 6 | KIT FRIGORIFISTA / REFRIGERATION KIT |
| 63300 | 1 | ARCO DE SIERRA HACK SAW |
| 64435 | 10 | HOJAS DE SIERRA 24 DIENTES ACERO AL CARBONO / CARBON STEEL HACKSAW BLADE |
| 69501 | 1 | CUTTER |
| 69604 | 1 | MARTILLO EBANISTA / JOINERS HAMMER |
| 62333 | 1 | ALICATE UNIVERSAL TITACROM BIMAT COMBINATION PLIERS |
| 62342 | 1 | ALICATE TELEFONISTA B/ CURVA TITACROM BIMAT BENT NOSE PLIERS |
| 62344 | 1 | ALICATE CORTAALAMBRES TITACROM BIMAT HEAVY DUTY CUTTING KNIPPERS |
| 62349 | 1 | ALICATE PELACABLES BIMAT WIRESTRIPPER PLIERS |
| 62297 | 1 | TENAZA CANAL BIMAT BOX JOINT PLIERS |
| 62178 | 1 | TENAZA GRIP CURVA / CURVED GRIP PLIERS |
| 61012 | 1 | MALETA / CASE |



| COD | PCS. | Kg |
|-------|------|------|
| 69393 | 116 | 19,5 |

| | | |
|---|----|--|
| 61701/61702/61703/61704/61705/61706/61707/61708/61709/61710/61711/61712/61713 | 13 | LLAVES FUJAS 6-7/8-9/10-11/12-13/14-15/16-17/18-19/20-22/21-23/24-26/25-28/27-29/30-32 |
| 61935 | 1 | LLAVE COMBI 12" UNIQUE ADJUSTABLE WRENCH COMBI |
| 61994 | 1 | LLAVE STILLSON 14" PIPE WRENCH |
| 61041 | 1 | LLAVE SUECA 45° 1" / 1" SWEDISH PIPE WRENCH COMBI |
| 61035 | 1 | LLAVE DE CADENA REVERSIBLE CHAIN PIPE WRENCH |
| 61500 | 10 | JUEGO LLAVES ALLEN 1,5/2/2,5/3/4/5/5,5/6/8/10 HEXAGONAL KEYS WRENCHES SET |
| 61099 | 1 | LLAVE DE LAVABO / BASIN WRENCH |
| 66875/66877/66879/66881/66882 | 5 | DESTORNILLADORES MECANICO ROTORK SLOTTED SCREWDRIVER |
| 66898/66899/66900 | 3 | DESTORNILLADORES PHILPS ROTORK PHILIPS SCREWDRIVER |
| 66909/66910 | 2 | DESTORNILLADORES POZDRIV ROTORK POZDRIV SCREWDRIVER |
| 66921/66926/66927 | 3 | DESTORNILLADORES TORX ROTORK TORX SCREWDRIVERS |
| 62333 | 1 | ALICATE UNIVERSAL TITACROM BIMAT COMBINATION PLIERS |
| 62344 | 1 | ALICATE CORTAALAMBRES TITACROM BIMAT HEAVY DUTY CUTTING KNIPPERS PLIERS |
| 62172 | 1 | TENAZA GRIP CURVA CURVED GRIP PLIERS |
| 62294 | 1 | TENAZA CANAL TITACROM BOX JOINT PLIERS |
| 62123 | 1 | TENAZA RUSA TITACROM TOWER Pincer |
| 63170 | 1 | CORTATUBOS CLASSIC 32 TUBE CUTTER |
| 63171 | 1 | CORTATUBOS ACERO 1 1/4" STEEL PIPE CUTTER |
| 63200 | 1 | TUERA PARA TUBO DE PLASTICO / PLASTIC PIPE CUTTER |
| 62159 | 1 | TUERA CORTACHAPA / TIN SNIP |
| 63300 | 1 | ARCO DE SIERRA HACK SAW |
| 64435 | 10 | HOJAS DE SIERRA 24 DIENTES ACERO AL CARBONO / CARBON STEEL HACKSAW BLADE |
| 69920 | 1 | MARTILLO ALEMAN / MACHINIST HAMMER |
| 69605 | 1 | MACETA / STONING HAMMER |
| 66003 | 1 | ABOCINADOR / FLARING TOOL |
| 69505 | 1 | DESATASCADOR DE MUELLE / SPRING PIPE CLEANER |
| 68043/68045/68054 | 3 | MUELLES CURVATUBOS 10/14/18 SPRING TUBE BENDERS |
| 61012 | 1 | MALETA / CASE |



| COD | PCS. | Kg |
|-------|------|----|
| 69397 | 69 | 19 |



52 PCS. JUEGOS ELECTRICIDAD / ELECTRICIAN SETS / JEUX ÉLECTRICIENS / WERKZEUGSÄTZE FÜR ELEKTRIZITÄT / KIT ELETTRICISTI / ELEKTRICIEN WERKTUIGSET JOGOS ÉCTRICIDADE



| COD | | pcs. | Kg. |
|-------|-------|------|-----|
| 68994 | - | 52 | 6 |
| 68995 | 51011 | 53 | 31 |

| Pcs. | Descripción / Description | Composición / Composition |
|------|--|--|
| 8 | Alicates / pliers 1000V | 62373, 62378, 62380, 62379, 62381, 62382, 62383, 62389 |
| 1 | tenaza cortacables / cable cutter 1000V | 73008 |
| 2 | Pinzas / tweezers 1000V | 73040, 73041 |
| 2 | Cuchillos / knives 1000V | 73035, 73036 |
| 1 | Cortacables de carraca / ratchet electrician cable cutter 1000V | 73011 |
| 1 | tenazas de canal / box joint 1000V | 73005 |
| 1 | llave ajustable / adjustable wrench 1000V | 61986 |
| 8 | llaves fijas una boca / single ended open jaw spaner 1000V | 73064, 73065, 73066, 73067, 73068, 73071, 73073, 73076 |
| 1 | tijera electricista / electrician's scissors | 69534 |
| 1 | alicate para terminales / terminals plier | 62494 |
| 1 | tester | 66076 |
| 6 | destornilladores electricistas / electrician screwdriver 1000V | 66430, 66431, 66432, 66433, 66434, 66435 |
| 5 | destornilladores phillips screwdriver 1000V | 66450, 66451, 66452, 66453, 66454 |
| 1 | soldador de estaño / soldering iron | 63253 |
| 1 | succionador con boquilla antiestática para soldadura desoldering pump with anti-static rubber nozzle | 63256 |
| 1 | espejo articulado / joint telescopic mirror | 65587 |
| 6 | vasos / sockets 1000V | 73232, 73233, 73234, 73236, 73238, 73239 |
| 1 | alargadera / extension 1000V | 73245 |
| 1 | carraca / ratchet 1000V | 73246 |
| 3 | boquillas hexagonales / hexagonal sockets 1000V | 73251, 73252, 73253 |

1 TOOLKITS

37 PCS. JUEGOS ELECTRICIDAD / ELECTRICIAN SETS / JEUX ÉLECTRICIENS / WERKZEUGSÄTZE FÜR ELEKTRIZITÄT / KIT ELETTRICISTI / ELEKTRICIEN WERKTUIGSET JOGOS ÉCTRICIDADE



| COD | | pcs. | Kg. |
|-------|-------|------|-----|
| 68996 | - | 37 | 3 |
| 68997 | 51010 | 38 | 7 |

| Pcs. | Descripción / Description | Composición / Composition |
|------|---|--|
| 5 | Alicates / pliers 1000V | 62373, 62379, 62381, 62383, 62389 |
| 1 | tenaza cortacables / cable cutter 1000V | 73008 |
| 1 | Pinzas / tweezers 1000V | 73040 |
| 1 | Cuchillos / knives 1000V | 73035 |
| 1 | tenazas de canal / box joint 1000V | 73005 |
| 5 | llaves fijas una boca / single ended open jaw spanner 1000V | 73064, 73065, 73067, 73068, 73070 |
| 1 | tijera electricista / electrician's scissors | 69534 |
| 1 | tester | 66076 |
| 5 | destornilladores electricistas / electrician screwdriver 1000V | 66430, 66431, 66432, 66433, 66434 |
| 3 | destornilladores phillips screwdriver 1000V | 66451, 66452, 66453 |
| 1 | soldador de estaño / soldering iron | 63253 |
| 1 | succionador con boquilla antiestática para soldadura desoldering pump with anti-static rubber nozzle | 63256 |
| 6 | vasos / sockets 1000V | 73232, 73233, 73234, 73236, 73238, 73239 |
| 1 | alargadera / extension 1000V | 73245 |
| 1 | carraca / ratchet 1000V | 73246 |
| 3 | boquillas hexagonales / hexagonal sockets 1000V | 73251, 73252, 73253 |

16 PCS.



| COD | | pcs. | Kg. |
|-------|-------|------|-----|
| 68998 | - | 16 | 2 |
| 68999 | 51013 | 17 | 4 |

| Pcs. | Descripción / Description | Composición / Composition |
|------|--|----------------------------|
| 3 | Alicates / pliers 1000V | 62373, 62379, 62383 |
| 1 | Pinzas / tweezers 1000V | 73040 |
| 1 | Cuchillos / knives 1000V | 73035 |
| 3 | llaves fijas una boca / single ended open jaw spanner 1000V | 73064, 73067, 73070 |
| 1 | tijera electricista / electrician's scissors | 69534 |
| 1 | buscapolos / voltage tester | 66071 |
| 4 | destornilladores electricistas / electrician screwdriver 1000V | 66430, 66431, 66433, 66434 |
| 2 | destornilladores phillips screwdriver 1000V | 66451, 66452 |

JUEGOS ELECTRICIDAD / ELECTRICIAN SETS / JEUX ÉLECTRICIENS / WERKZEUGSÄTZE FÜR ELEKTRIZITÄT / KIT ELETTRICISTI / ELEKTRICIEN WERKTUIGSET / JOGOS ÉCTRICIDADE

| COD | |
|-------|---|
| 62512 | Alicates universales Mastercut 1000V 200mm Combination pliers |
| 62383 | Alicate corte diagonal 1000V 160mm Diagonal cutting pliers |
| 62379 | Alicates telefonista recto 1000V 160mm Long nose pliers |
| 62389 | Alicate pelacables 1000V 160mm Wirestripper |
| 62494 | Alicate para terminales 220mm Crimping pliers |
| 66431 | Destornillador electricista 1000V 4x125 Screwdriver |
| 66433 | Destornillador electricista 1000V 6,5x150 Screwdriver |
| 66451 | Destornillador Philips 1000V PH1 Screwdriver |
| 66452 | Destornillador Philips 1000V PH2 Screwdriver |
| 66422 | Destornillador electricista 3x100 Electrician screwdriver |
| 66423 | Destornillador electricista 4x125 Electrician screwdriver |
| 66425 | Destornillador electricista 5,5x150 Electrician screwdriver |
| 66426 | Destornillador electricista 6,5x150 Electrician screwdriver |
| 66427 | Destornillador electricista 8x175 Electrician screwdriver |
| 66072 | Buscapolos 150mm Voltage tester |
| 69526 | Navaja 120mm Penknife |
| 69662 | Maceta modelo español 1000grs. Spanish type stoning hammer |
| 69534 | Tijera electricista 145mm Electrician's scissors |
| 65167 | Flexómetro robust magnet 5x25 Measuring tape |
| 63300 | Arco de sierra / Hack saw |
| 51013 | Bolsa portaherramientas / Tool bag |



| COD | PCS. | Kg |
|-------|------|-----|
| 69536 | 21 | 4,2 |

| | | |
|-------------------------------|----|---|
| 61958 | 29 | JUEGO DE 29 UN 1/4" SET |
| 69244 | 6 | JUEGO DE LLAVES FLIAS 6-7/8-9/10-11/12-13/14-15/16-17 OPEN END WRENCHES SET |
| 61110 | 1 | LLAVE AJUSTABLE 6" UNIQUE PLUS TITACROM ADJUSTABLE WRENCH |
| 66846/66847/66848/66849 | 4 | DESTORNILLADORES BOCA PLANA MICROTRONIC FLAT NOSE SCREWDRIVERS |
| 66850/66851/66852 | 3 | DESTORNILLADORES PHILIPS MICROTRONIC PHILIPS SCREWDRIVERS |
| 66853/66854 | 2 | DESTORNILLADORES POZIDRIV MICROTRONIC POZIDRIV SCREWDRIVERS |
| 66855/66856/66857/66858/66859 | 5 | DESTORNILLADORES TORX MICROTRONIC TORX SCREWDRIVERS |
| 66862/66863/66864/66865 | 4 | DESTORNILLADORES HEXAGONALES MICROTRONIC HEXAGONAL SCREWDRIVERS |
| 66866/66867/66868/66869 | 3 | DESTORNILLADORES VARILLA PROTEGIDA ROTORK INSULATED SCREWDRIVERS |
| 66903/66904 | 2 | D. VARILLA PROTEGIDA PHILIPS ROTORK PHILIP INSULATED SCREWDRIVERS |
| 66913/66914 | 2 | D. VARILLA PROT. POZIDRIV ROTORK POZIDRIV INSULATED SCREWDRIVERS |
| 66928/66929/66930 | 3 | DESTORNILLADORES PUNTA ESFERA ROTORK PHILIPS BALL TIP SCREWDRIVERS |
| 66937/66938/66939 | 3 | DESTORNILLADORES TORX ROTORK TORX SCREWDRIVERS |
| 66970 | 1 | DESTORNILLADOR BUSCAPOLOS / VOLTAGE TESTER SCREWDRIVER |
| 61499 | 8 | JUEGO LLAVES ALLEN 1.5/2/2.5/3/4/5/5.5/6 HEXAGONAL KEYS WRENCHES SET |
| 61870/61871/61872/61873/61874 | 5 | LLAVES DE PIPA 6/7/8/9/10 ANGLED OPEN SOCKETS |
| 61824/61825/61826/61827 | 4 | LLAVES TUBO 6-7/8-9/10-11/12-13 SOCKET DOUBLE ENDED WRENCHES |
| 62241 | 1 | ALICATE MINI UNIVERSAL TITACROM BIMAT COMBINATION ELECTRONIC PLIERS |
| 62242 | 1 | ALICATE MINI B/PLANA TITACROM BIMAT FLAT NOSE ELECTRONIC PLIERS |
| 62243 | 1 | ALICATE MINI B/REDONDA TITACROM BIMAT ROUND NOSE ELECTRONIC PLIERS |
| 62244 | 1 | ALICATE MINI TELEFONISTA TITACROM BIMAT LONG NOSE ELECTRONIC PLIERS |
| 62245 | 1 | ALICATE MINI B/CURVA TITACROM BIMAT BENT NOSE ELECTRONIC PLIERS |
| 62246 | 1 | ALICATE MINI B/AGUJA TITACROM BIMAT LONG NEEDLE NOSE ELECTRONIC PLIERS |
| 62247 | 1 | ALICATE MINI C/DIAGONAL TITACROM BIMAT DIAGONAL CUTTING ELECTRONIC PLIERS |
| 62249 | 1 | ALICATE MINI C/FRONTAL TITACROM BIMAT END CUTTER ELECTRONIC PLIERS |
| 69529 | 4 | PINZAS SET-4 NEAT TIPS/FLAT NOSE/45°/SELF ADJUSTING TWEEZERS |
| 69501 | 1 | CUTTER |
| 69601 | 1 | MARTILLO EBANISTA / JOINERS HAMMER |
| 51612 | 1 | MALETA / CASE |



| COD | PCS. | Kg |
|-------|------|----|
| 69390 | 100 | 8 |

| | | |
|-------------------------------|----|---|
| 61958 | 29 | JUEGO DE 29 UN 1/4" SET |
| 69245 | 8 | JUEGO DE LLAVES FLIAS 6-7/8-9/10-11/12-13/14-15/16-17/18-19/20-22 OPEN END WRENCHES SET |
| 61816/61817/61818/61819 | 10 | LLAVES ALLEN P/BOLA 1.5/2/2.5/3/4/5/5.5/6/6/10 HEXAGONAL KEYS WRENCHES |
| 61820/61821/61822/61823/61824 | 4 | DESTORNILLADORES VARILLA PROTEGIDA ROTORK INSULATED SCREWDRIVERS |
| 66893/66894/66895/66896 | 4 | D. VARILLA PROTEGIDA PHILIPS ROTORK PHILIPS INSULATED SCREWDRIVERS |
| 66903/66904/66905/66906 | 4 | D. VARILLA PROT. POZIDRIV ROTORK POZIDRIV INSULATED SCREWDRIVERS |
| 66913/66914/66915/66916 | 1 | DESTORNILLADOR BUSCAPOLOS / VOLTAGE TESTER SCREWDRIVER |
| 66070 | 1 | LLAVE AJUSTABLE 10" UNIQUE PLUS TITACROM 1000V ADJUSTABLE WRENCH |
| 61996 | 1 | ALICATE UNIVERSAL 1000V COMBINATION PLIERS |
| 62373 | 1 | ALICATE B/PLANA 1000V FLAT NOSE PLIERS |
| 62377 | 1 | ALICATE B/REDONDA 1000V ROUND NOSE PLIERS |
| 62378 | 1 | ALICATE TELEFONISTA 1000V LONG NOSE PLIERS |
| 62379 | 1 | ALICATE TELEFONISTA B/CURVA 1000V BENT NOSE PLIERS |
| 62381 | 1 | ALICATE C/DIAGONAL 1000V DIAGONAL CUTTING PLIERS |
| 62383 | 1 | ALICATE C/FRONTAL 1000V END CUTTER PLIERS |
| 62389 | 1 | ALICATE PELACABLES 1000V WIRESTRIPPER PLIERS |
| 62445 | 1 | TENAZA PICO LORO BIMAT GROOVE JOINT |
| 62178 | 1 | TENAZA GRIP 7" GRIP PLIERS |
| 62181 | 1 | TENAZA CORTACABLES / CABLE CUTTER |
| 69501 | 1 | CUTTER |
| 63382 | 1 | ARCO DE SIERRA TIPO B T/PE HACK SAW |
| 64435 | 10 | HOJA DE SIERRA 24 DIENTES ACERO AL CARBONO / CARBON STEEL HACKSAW BLADE |
| 69603 | 1 | MARTILLO EBANISTA / JOINERS HAMMER |
| 51012 | 1 | MALETA / CASE |



| COD | PCS. | Kg |
|-------|------|------|
| 69391 | 85 | 11,5 |

ELECTROMECHANICA / ELECTROMECHANICAL KIT / KIT ÉLECTROMECANIQUE / WERKZEUGSATZ FÜR ELEKTROMECHANIKER / ELETTRMECCANICA / ELEKTRO-MECHANICA KIT / ELECTROMECÂNICA

| | | |
|---|----|---|
| 61958 | 29 | JUEGO DE 29 UN 1/4" SET |
| 01025/01026/01027/01028/01029 01030/01031/01032/01033/01034 | 10 | LLAVES COMBINADAS 6/7/8/9/10/11/12/13/14/15 COMBINATION WRENCHES |
| 01999 | 1 | LLAVE AJUSTABLE 10" UNIQUE PLUS TITACROM COMFORT ADJUSTABLE WRENCH |
| 00093/00094/00095/00096 00097/00098/00099 | 4 | DESTORNILLADORES VARILLA PROTEGIDA ROTORK INSULATED SCREWDRIVERS |
| 00103/00104/00105 | 3 | D. VARILLA PROT. POZIDRIV ROTORK PHILIPS INSULATED SCREWDRIVERS |
| 00028/00029/00030/00031/00032 00017/00018/00019/00020/00021 00034/00035 | 5 | DESTORNILLADORES TORX ROTORK TORX SCREWDRIVERS |
| 00071 | 2 | DESTORNILLADORES ROBERTSON ROTORK ROBERTSON SCREWDRIVERS |
| 01024/01025/01026/01027/01028 | 5 | DESTORNILLADOR BUSCAPOLOS / VOLTAGE TESTER SCREWDRIVER |
| 01499 | 8 | LLAVES TUBO 6-7/8-9/10-11/12-13/14-15 SOCKET DOUBLE ENDED WRENCHES |
| 02177 | 1 | JUEGO LLAVES ALLEN 1,5/2/2,5/3/4/5/5,5/6/8/10 HEXAGONAL KEYS WRENCHES SET |
| 02331 | 1 | TENAZA GRIP CURVA CURVED GRIP PLIERS |
| 02337 | 1 | ALICATE UNIVERSAL TITACROM BIMAT COMBINATION PLIERS |
| 02339 | 1 | ALICATE B/PLANA TITACROM BIMAT FLAT NOSE PLIERS |
| 02341 | 1 | ALICATE TELEFONISTA TITACROM BIMAT LONG NOSE PLIERS |
| 02343 | 1 | ALICATE TELEFONISTA B/CURVA TITACROM BIMAT BENT NOSE PLIERS |
| 02349 | 1 | ALICATE CORTE DIAGONAL TITACROM BIMAT DIAGONAL CUTTING PLIERS |
| 02445 | 1 | ALICATE PELACABLES TITACROM BIMAT WIRESTRIPPER |
| 02214 | 1 | TENAZA PICO LORO BIMAT GROOVE JOINT |
| 02218 | 1 | ALICATE CIRCLIPS EXTERIOR RECTO / EXTERNAL STRAIGHT CIRCLIPS PLIERS |
| 02222 | 1 | ALICATE CIRCLIPS INTERIOR RECTO / INTERNAL STRAIGHT CIRCLIPS PLIERS |
| 02225 | 1 | ALICATE CIRCLIPS INTERIOR CURVO / INTERNAL BENT CIRCLIPS PLIERS |
| 09083 | 1 | MARTILLO EBANISTA / JOINERS HAMMER |
| 09031 | 1 | PINZA 45° TWEEZERS |
| 09033 | 1 | PINZA B/PLANA / FLAT NOSE TWEEZERS |
| 09032 | 1 | PINZA AUTOAPRETANTE / SELF ADJUSTING TWEEZERS |
| 09453 | 8 | ALICATES KIT-5 PLIERS |
| 09304 | 1 | MAGNETIZADOR / MAGNETIZER |
| 09001 | 1 | CUTTER |
| 01012 | 1 | MALETA / CASE |



| COD | PCS. | Kg |
|-------|------|------|
| 69392 | 100 | 10,5 |

MANTENIMIENTO DE EDIFICIOS / BUILDING MAINTENANCE / KIT POUR L'ENTRETIEN DE BÂTIMENT / WERKZEUGSATZ FÜR GEBÄUDEWARTUNG / EDILIZIA INDUSTRIALE ONDERHOUDSKIT / MANUTENÇÃO DE EDIFICIOS

| | | |
|--|----|--|
| 09245 | 8 | JUEGO DE LLAVES FUAS 6-7/8-9/10-11/12-13/14-15/16-17/18-19/20-22 OPEN END WRENCHES SET |
| 01113 | 1 | LLAVE AJUSTABLE 12" UNIQUE PLUS TITACROM ADJUSTABLE WRENCH |
| 01024/01025/01026/01027 01028/01029/01030/01031 | 8 | LLAVES TUBO 6-7/8-9/10-11/12-13/14-15/16-17/18-19/20-22 SOCKET DOUBLE ENDED WRENCHES |
| 01500 | 10 | JUEGO LLAVES ALLEN 1,5/2/2,5/3/4/5/5,5/6/8/10 HEXAGONAL KEYS WRENCHES SET |
| 02332 | 1 | ALICATE UNIVERSAL TITACROM BIMAT COMBINATION PLIERS |
| 02344 | 1 | ALICATE CORTAALAMBRES TITACROM BIMAT HEAVY DUTY CUTTING NIPPERS |
| 02297 | 1 | TENAZA CANAL BIMAT BOX JOINT PLIERS |
| 02172 | 1 | TENAZA GRIP CURVE CURVED GRIP PLIERS |
| 02349 | 1 | ALICATE PELACABLES TITACROM BIMAT WIRESTRIPPER |
| 02134 | 1 | TENAZA RUSA TITACROM TOWER PNCER |
| 01005 | 1 | LLAVE STILLSON 18" / STILLSON WRENCH |
| 03300 | 1 | ARCO DE SIERRA HACK SAW |
| 04435 | 10 | HOJAS DE SIERRA 34 DIENTES ACERO AL CARBONO / CARBON STEEL HACKSAW BLADE |
| 02130 | 1 | TUERA CORTACHAPA / TIN SNIP |
| 09001 | 1 | CUTTER |
| 02151 | 1 | TENAZA CORTACABLES/CABLE CUTTER |
| 09014 | 1 | MARTILLO DE BOLA / BALL PEIN HAMMER |
| 09028 | 1 | MARTILLO UÑA MOD. AMERICANO / CLAW HAMMER |
| 09544 | 1 | MARTILLO DE NYLON HAMMER |
| 09520 | 1 | MACETA GOMA / RUBBER HAMMER |
| 00075/00077/00079/00081/00082 00083/00089 00094/00095 00094/00095 00097/00098 00099/00100 | 5 | DESTORNILLADORES MECANICO ROTORK SLOTTED SCREWDRIVERS |
| | 2 | DESTORNILLADORES POZIDRIV ROTORK POZIDRIV SCREWDRIVERS |
| | 2 | DESTORNILLADORES VARILLA PROTEGIDA ROTORK INSULATED SCREWDRIVERS |
| | 2 | D. VARILLA PROTEGIDA PHILIPS ROTORK PHILIPS INSULATED SCREWDRIVERS |
| | 2 | DESTORNILLADORES TORX ROTORK TORX SCREWDRIVERS |
| | 1 | DESTORNILLADOR BUSCAPOLOS / VOLTAGE TESTER SCREWDRIVERS |
| | 1 | CARRACA / RATCHER |
| | 2 | CABEZAS / HEADS |
| | 1 | DESATASCADOR DE MUELLE / SPRING PIPE CLEANER |
| | 1 | KIT REPARADOR DE GRIFOS / VALVE RESEATER |
| | 1 | PALETA MOD. MADRID BRICKLAYER |
| | 1 | ESPATULA / SCRAPER |
| | 1 | MALETA / CASE |



| COD | PCS. | Kg |
|-------|------|----|
| 69395 | 74 | 20 |

ASISTENCIA DE EQUIPOS DOMESTICOS / HOUSE EQUIPMENT KIT / KIT ÉQUIPEMENT DE MAISON / WERKZEUGSATZ HAUSAUSRÜSTUNG / ASSISTENZA APPARECCHI DOMESTICI / HOME KIT / ASSISTÊNCIA A ELECTRODOMESTICOS

| | | |
|---|----|--|
| 01950 | 29 | JUEGO DE 29 UN 1/4" SET |
| 09245 | 8 | JUEGO DE LLAVES FUAS 6-7/8-9/10-11/12-13/14-15/16-17/18-19/20-22 OPEN END WRENCHES SET |
| 01070/01071/01072/01073/01074 01075/01076/01077/01078 | 9 | LLAVES DE PIRA 6/7/8-9/10/11/12/13/14 ANGLED OPEN SOCKETS |
| 01499 | 8 | JUEGO LLAVES ALLEN 1,5/2/2,5/3/4/5/5,5/6/8/10 HEXAGONAL KEYS WRENCHES SET |
| 01111 | 1 | LLAVE AJUSTABLE 8" UNIQUE TITACROM ADJUSTABLE WRENCH |
| 00093/00094/00095 00096/00097/00098/00099 00103/00104/00105 00017/00018/00019 00034/00035/00036 | 3 | DESTORNILLADORES VARILLA PROTEGIDA ROTORK INSULATED SCREWDRIVERS |
| | 3 | D. VARILLA PROT. POZIDRIV ROTORK PHILIPS INSULATED SCREWDRIVERS |
| | 3 | D. VARILLA PROT. POZIDRIV ROTORK POZIDRIV INSULATED SCREWDRIVERS |
| | 3 | DESTORNILLADORES TORX ROTORK TORX SCREWDRIVERS |
| | 3 | DESTORNILLADORES TORX ROTORK TORX SCREWDRIVERS |
| | 3 | DESTORNILLADORES TORX ROTORK TORX SCREWDRIVERS |
| | 3 | DESTORNILLADORES TORX ROTORK TORX SCREWDRIVERS |
| | 3 | DESTORNILLADORES TORX ROTORK TORX SCREWDRIVERS |
| | 1 | DESTORNILLADOR BUSCAPOLOS / VOLTAGE TESTER SCREWDRIVER |
| | 1 | ALICATE UNIVERSAL TITACROM BIMAT COMBINATION PLIERS |
| | 1 | ALICATE B/PLANA TITACROM BIMAT FLAT NOSE PLIERS |
| | 1 | ALICATE B/BREDONDA TITACROM BIMAT ROUND NOSE PLIERS |
| | 1 | ALICATE TELEFONISTA B/CURVA TITACROM BIMAT BENT NOSE PLIERS |
| | 1 | ALICATE C/DIAGONAL TITACROM BIMAT DIAGONAL CUTTING PLIERS |
| | 1 | ALICATE PELACABLES BIMAT WIRESTRIPPER PLIERS |
| | 1 | TENAZA PICO LORO BIMAT GROOVE JOINT |
| | 1 | TENAZA GRIP CURVE CURVED GRIP PLIERS |
| | 1 | PINZA 45° TWEEZERS |
| | 1 | PINZA B/FINA NEAT TIPS TWEEZER |
| | 1 | ALICATE MINI B/PLANA TITACROM BIMAT FLAT NOSE ELECTRONIC PLIERS |
| | 1 | ALICATE MINI C/DIAGONAL TITACROM BIMAT DIAGONAL CUTTING ELECTRONIC PLIERS |
| | 1 | ALICATE MINI B/AGUJA TITACROM BIMAT LONG NEEDLE NOSE ELECTRONIC PLIERS |
| | 1 | CORTATUBOS MINI 22 TUBE CUTTER |
| | 1 | CUTTER |
| | 1 | MARTILLO EBANISTA / JOINERS HAMMER |
| | 1 | MALETA / CASE |



| COD | PCS. | Kg |
|-------|------|-----|
| 69394 | 88 | 9,5 |

1

TOOLKITS

MALETA DE ALUMINIO PORTAHERRAMIENTAS / ALUMINIUM TOOL CASE / MALETTE PORTE-OUTILS / ALUMINIUMKOFFER ZUM ROLLEN
VALIGIA IN ALUMINIO PORTAUTENSILI / MALA DE ALUMINIO PORTAFERRAMENTAS

| COD | LxWxH | Kg |
|-------|-------------|-----|
| 51012 | 455x205x320 | 4,2 |

Cerradura de combinación / Number combination lock / Serrure à code
Asa telescópica / Telescopic handle / Anse télescopique
Ruedas / Wheels / Roues



MALETA PORTAHERRAMIENTAS / TOOL CASE / MALETTE PORTE-OUTILS / WERKZEUGKOFFER / VALIGIA PORTAUTENSILI / KOFER
MALA PORTAFERRAMENTAS

| COD | LxWxH | Kg |
|-------|-------------|-----|
| 51010 | 485x200x380 | 3,8 |

ABS Extra resistente / Extra-resistant ABS / ABS extra-résistant
Cerradura con llave / Key lock / Serrure à clef



CAJAS DE HERRAMIENTAS / TOOL BOXES / CAISSES A OUTILS / WERKZEUGKASTEN / GEREEDSCHAPSKIST
CASSA PORTAUTENSILI / CAIXAS DE FERRAMENTAS

| COD | LxWxH | Kg |
|-------|-------------|----|
| 51022 | 460x210x170 | 3 |

3 elementos / 3 compartments / 3 cases / 3 teilig



| COD | LxWxH | Kg |
|-------|-------------|-----|
| 51023 | 500x200x215 | 4,6 |

5 elementos / 5 compartments / 5 cases / 5 teilig



| COD | LxWxH | Kg |
|-------|-------------|-----|
| 51038 | 404x200x195 | 3,3 |

5 elementos / 5 compartments / 5 cases / 5 teilig



CARROS PORTAHERRAMIENTAS / ROLLER CABINETS / SERVANTES WERKZEUGWAGEN CARRELLO PORTAUTENSILI / GEREEDSCHAPSWAGEN / CARROS PORTA FERRAMENTAS

COFRE PORTAHERRAMIENTAS / TOOL CHEST / COFFRES A OUTILS / WERKSTATT KASTEN MIT SCHUBLADEN / KIST MET LADEN
CASSETTIERE PORTAUTENSILI / BAÚS DE FERRAMENTAS

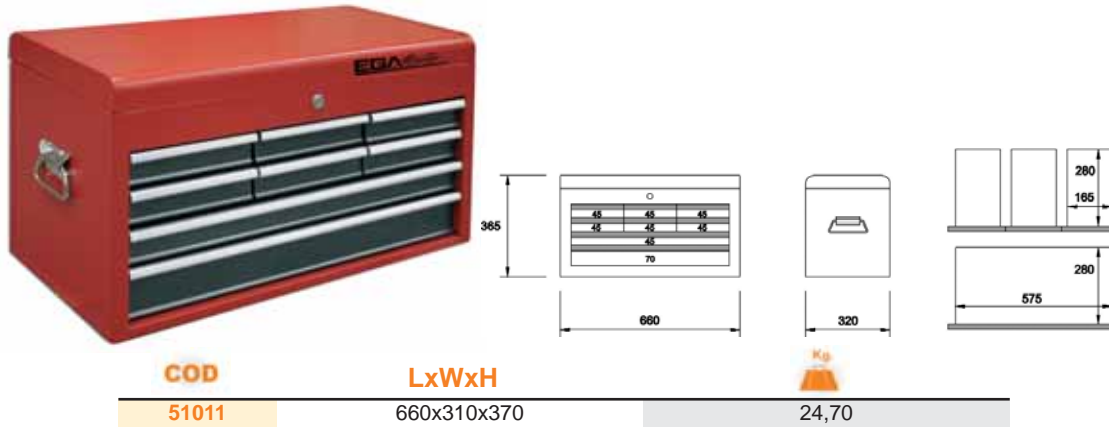

COD

LxWxH

Kg

51011

660x310x370

24,70

Especificaciones técnicas / Technical specification / Détails techniques

| | |
|---|---|
| 8 cajones con rodamientos / 8 Ball-bearing slides / 8 Tiroirs à roulement | ● |
| Asas laterales / Lateral handles / Anses latérales | ● |
| Cerradura con llave / Key lock / Serrure à clef | ● |

ARMARIOS PORTAHERRAMIENTAS CON RUEDAS / ROLLER CABINETS / SERVANTES A ROUES / WERKSTATTWAGEN
GEREEDSCHAPSWAGEN / ARMADIO PORTAUTENSILI CON RUOTE / ARMARIOS PORTAFERRAMENTAS COM RODAS



COD

LxWxH

Kg

51024

690x435x780

40

Especificaciones técnicas / Technical specification / Détails techniques

| | |
|---|--------|
| 5 cajones con rodamientos / 5 Ball-bearing slides / 5 Tiroirs à roulement | ● |
| 2 ruedas fijas y 2 giratorias con freno / 2 fixed and 2 revolving with brake wheels 2 roues fixes et 2 roues giratoires avec frein | 4"X1" |
| Capacidad de carga estática total / Total static weight capacity Capacité totale de charge statique | 300 Kg |
| Sistema de cierre centralizado / Central locking system Système de fermeture centralisée | ● |
| Estructura reforzada / Reinforced heavy duty structure / Structure renforcée | ● |

ARMARIOS PORTAHERRAMIENTAS CON RUEDAS / ROLLER CABINETS / SERVANTES A ROUES / WERKSTATTWAGEN
GEREEDSCHPSWAGEN / ARMADIO PORTAUTENSILI CON ROUTE / ARMARIOS PORTAFERRAMENTAS COM RODAS



COD

LxWxH

51045

695x570x1365

63

Especificaciones técnicas / Technical specification / Détails techniques

| | |
|--|--------|
| 7 cajones con rodamientos / 7 Ball-bearing slides / 7 Tiroirs à roulement | ● |
| 2 ruedas fijas y 2 giratorias con freno / 2 fixed and 2 revolving with brake wheels 2 roues fixes et 2 roues giratoires avec frein | 5"X2" |
| Capacidad de cada cajón / capacity in each drawer / Capacité de chaque tiroir | 15 Kg |
| Capacidad de carga estática total / Total static weight capacity Capacité totale de charge statique | 300 Kg |
| Numero de agujeros del panel / Number of holes of the panel Nombre de trous du panneau | 12&12 |
| Panel accionado neumaticamente / Pneumatically operated panel Panneau actionné pneumatiquement | ● |
| Sistema de cierre centralizado en el panel y en el carro / Central locking system in the panle and in the cabinet / Système de fermeture centralisée dans le panneau et la servante | ● |
| Estructura reforzada / Reinforced heavy duty structure / Structure renforcée | ● |

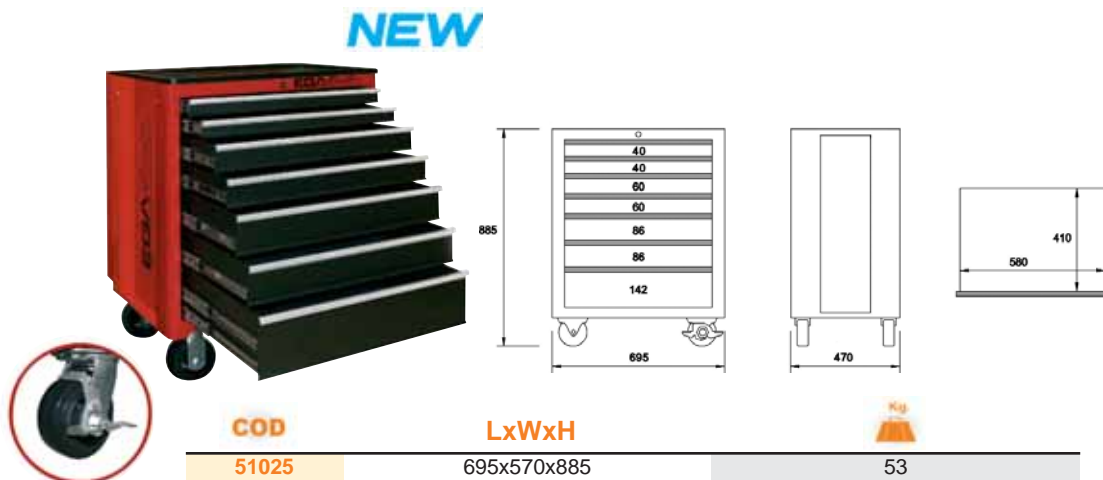

COD

LxWxH

51025

695x570x885

53

Especificaciones técnicas / Technical specification / Détails techniques

| | |
|---|--------|
| 7 cajones con rodamientos / 7 Ball-bearing slides / 7 Tiroirs à roulement | ● |
| 2 ruedas fijas y 2 giratorias con freno / 2 fixed and 2 revolving with brake wheels 2 roues fixes et 2 roues giratoires avec frein | 5"X2" |
| Capacidad de cada cajón / capacity in each drawer / Capacité de chaque tiroir | 15 Kg |
| Capacidad de carga estática total / Total static weight capacity Capacité totale de charge statique | 300 Kg |
| Sistema de cierre centralizado / Central locking system / Système de fermeture centralisée | ● |
| Estructura reforzada / Reinforced heavy duty structure / Structure renforcée | ● |

ARMARIOS PORTAHERRAMIENTAS CON RUEDAS / ROLLER CABINETS / SERVANTES A ROUES / WERKSTATTWAGEN
GEREEDSCHPSWAGEN / ARMADIO PORTAUTENSILI CON RUOTE / ARMARIOS PORTAFERRAMENTAS COM RODAS

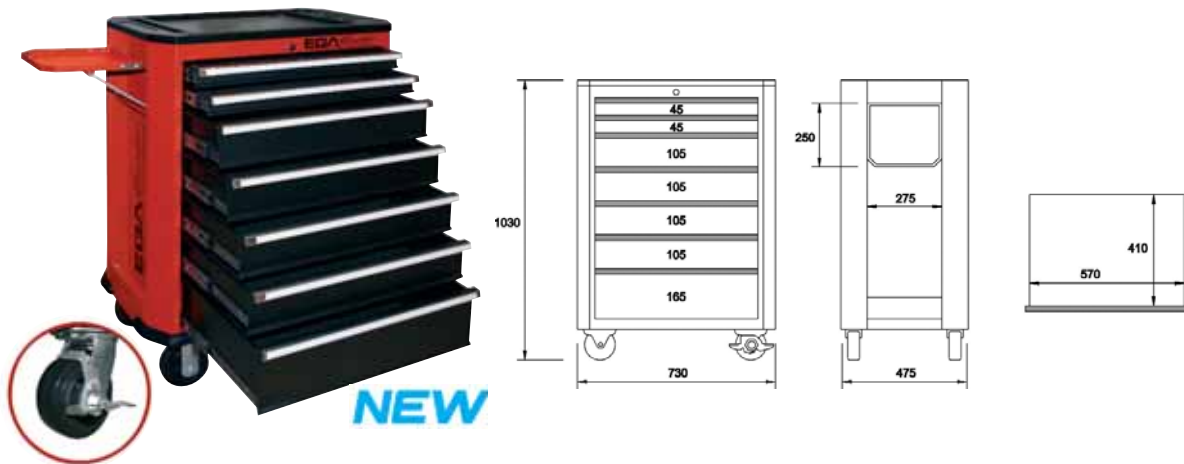

COD

LxWxH



51039

730x470x1030

53

Especificaciones técnicas / Technical specification / Détails techniques

| | |
|---|--------|
| 7 cajones con rodamientos / 7 Ball-bearing slides / 7 Tiroirs à roulement | ● |
| 2 ruedas fijas y 2 giratorias con freno / 2 fixed and 2 revolving with brake wheels 2 roues fixes et 2 roues giratoires avec frein | 5"X2" |
| Capacidad de cada cajón / capacity in each drawer / Capacité de chaque tiroir | 15 Kg |
| Capacidad de carga estática total / Total static weight capacity Capacité totale de charge statique | 300 Kg |
| Panel accionado neumáticamente / Pneumatically operated panel Panneau actionné pneumatiquement | ● |
| Sistema de cierre centralizado / Central locking system / Système de fermeture centralisée | ● |
| Estructura reforzada / Reinforced heavy duty structure / Structure renforcée | ● |
| Bandeja lateral plegable / Lateral foldable tray / Plateaux latéraux pliables | ● |
| Colgador lateral para herramientas / Lateral tool holder / Rangement latéral d'outils | ● |
| Sistema antivuelco en cada bandeja / Anti-overturn system in each drawers Système anti-chute dans chaque tiroir | ● |

EGA Master S.A.
ART IN INNOVATION



ARMARIOS PORTAHERRAMIENTAS CON RUEDAS / ROLLER CABINETS / SERVANTES A ROUES / WERKSTATTWAGEN
GEREEDSCHPSWAGEN / ARMADIO PORTAUTENSILI CON ROUTE / ARMARIOS PORTAFERRAMENTAS COM RODAS



COD

LxWxH



51040

1100x470x1030

94,5

Especificaciones técnicas / Technical specification / Détails techniques

| | |
|---|--------|
| 7 cajones y 1 armario / 7 drawers and 1 closet / 7 tiroirs et une armoire | ● |
| 2 ruedas fijas y 2 giratorias con freno / 2 fixed and 2 revolving with brake wheels 2 roues fixes et 2 roues giratoires avec frein | 5"X2" |
| Capacidad de cada cajón / capacity in each drawer / Capacité de chaque tiroir | 15 Kg |
| Capacidad de carga estática total / Total static weight capacity Capacité totale de charge statique | 500 Kg |
| Panel accionado neumáticamente / Pneumatically operated panel Panneau actionné pneumatiquement | ● |
| Sistema de cierre centralizado / Central locking system / Système de fermeture centralisée | ● |
| Estructura reforzada / Reinforced heavy duty structure / Structure renforcée | ● |
| Bandeja lateral / Foldable tray / Plateaux latéraux | ● |
| Colgador lateral para herramientas / Lateral tool holder / Rangement latéral d'outils | ● |
| Sistema antivuelco en cada bandeja / Anti-overturn system in each drawers Système anti-chute dans chaque tiroir | ● |



MESA DE TRABAJO / WORK BENCH / TABLE DE MONTEUR / ARBEITSTISCH / WERKTAFEL
MESAS DE TRABALHO



Especificaciones técnicas / Technical specification / Détails techniques

| | |
|--|---|
| Cajones con rodamientos / Ball bearing slide drawers / Tiroirs à roulement | ● |
| Sistema de cierre centralizado / Central locking system / Système de fermeture centralisée | ● |

ARMARIO DE PARED / WALL CABINET / ARMOIRE MURALE / WANDWERKZEUGSCHRANK
ARMADIO DA PARETE / WANDWERKTUIGKAST / ARMÁRIO DE PAREDE



Especificaciones técnicas / Technical specification / Détails techniques

| | |
|---|---|
| Baldas / Shelves / Rayons | 3 |
| Cerradura con llave / Key lock / Serrure avec clé | ● |



1

TOOLKITS

BOLSAS PORTAHERRAMIENTAS / TOOL BAGS / SACS PORTE-OUTILS / WERKZEUGTASCHE / BORSA PORTAUTENSILI
GEREEDSCHAPSTAS / BOLSA PORTA FERRAMENTAS

| COD | LxWxH | |
|-------|-------------|----|
| 51014 | 495x265x340 | 50 |



| COD | LxWxH | |
|-------|-------------|----|
| 51034 | 400x265x295 | 32 |



| COD | LxWxH | |
|-------|-------------|----|
| 51013 | 400x215x305 | 22 |



| COD | LxWxH | |
|-------|-------------|----|
| 51033 | 400x230x295 | 16 |



CHALECO / VEST / VESTE / MANTEL / MAGLIA / VEST / COLETE

| COD | LxW |
|-------|---------|
| 51015 | 510x600 |



CINTURON PORTAHERRAMIENTAS / TOOL BELT / CEINTURE PORTE - OUTILS / WERKZEUGGÜRTEL / CINTURA PORTAUTENSILI
GEREEDSCHAPSRIEM / CINTURAO PORTA FERRAMENTAS

| COD | L |
|-------|---------|
| 51009 | 32"-44" |





ALICATE MASTERCUT: EL MÁS PROFESIONAL DEL MERCADO
MASTERCUT PLIER: THE MOST PROFESSIONAL IN THE MARKET
PINCE MASTERCUT: LA PLUS PROFESSIONELLE DU MARCHÉ



Premio a la Innovación, Certamen Metalmaq, Lisboa 2001
 Innovation Award, Metalmaq, Lisbon 2001
 Prix a L'Innovation, Metalmaq, Lisbonne 2001

Medalla de Bronce, Salon Internacional de la Invención, París 2004
 Bronze Medal, International Inventors Competition, Paris 2004
 Medaille de Bronze, Salon International de L'Invention, Paris 2004

1 Gracias a su sistema de eje desplazado y a la tecnología aplicada en sus bocas, la capacidad de corte se ha incrementado en un 60% respecto a los alicates tradicionales. Corta clavos de hasta 5mm de diámetro.

Displaced joint axle high-leverage system, together with the applied technology on the jaws, provides 60% higher cutting capacity than traditional pliers. Cuts nails up to 5mm.

Grâce à un système d'axe déplacé, la capacité de coupe est augmentée de 60% par rapport à une pince traditionnelle. Coupe des clous de 5mm de diamètre.

2 Eje poligonal extrafuerte para larga duración y suavidad de funcionamiento sin holgura.

Polygonal super-resistant axle pin, long lasting and smooth action.

Axe polygonal extrafort longue durée.

3 Sistema de engastar terminales en los alicates universales.

Terminal Crimping system for combination pliers.

Incluent la fonction sertissage de terminaux.

4 TITACROM® -tratamiento superficial especial, resistente a la corrosión y a los golpes y roces, es antirreflejante y de gran atractivo.

TITACROM® - special surface treatment, rust-proof and anti-chipping off, it is non-reflecting and with very attractive finishing.

TITACROM® traitement superficiel spécial, résistant à la corrosion et aux coups, anti-réfléchissant et au desing attirant.

5 Mango bicomponente BIMAT® ergonómico para un agarre ideal, antideslizante y cómodo.

BIMAT® 2 component ergonomic and anti-slippery handles provide comfortable gripping.

Manche bi-matière ergonomique pour la meilleure accroche.

6 Patentado.

Patented.

Breveté.



capacidad de corte
 cutting capacity
 capacité de coupe

60% +

MASTERCUT TITACROM BIMAT

TITACROM® BIMAT

UNIVERSALES
COMBINATION
UNIVERSELLES
KOMBIZANGEN
UNIVERSALE
COMBINATIETANG
UNIVERSAIS



| COD | L mm | mm | mm | mm |
|-------|------|-----|----|----|
| 62495 | 165 | 220 | | |
| 62496 | 180 | 230 | | |
| 62497 | 200 | 280 | 6 | 1 |
| 62479 | 210 | 280 | | |
| 62537 | 220 | 310 | | |
| 62480 | 235 | 380 | | |

TELEFONISTA
LONG NOSE
TELEPHONE
TELEFONZANGEN
TELEFONISTI
TELEFOONTANG
TELEFONISTA



DIN 5745

| COD | L mm | mm | mm | mm |
|-------|------|-----|----|----|
| 62498 | 160 | 170 | 6 | 1 |
| 62499 | 200 | 210 | | |

TELEFONISTA BOCA CURVA
BENT NOSE PLIERS
TELEPHONE BECS COUDES
TELEFONZANGEN GEBOGEN
TELEFONISTI BECCHI PIEGATI
RADIO TANG MET GEBOGEN BEKKEN
TELEFONISTA PONTAS CURVAS



DIN 5745

| COD | L mm | mm | mm | mm |
|-------|------|-----|----|----|
| 62500 | 160 | 170 | 6 | 1 |
| 62501 | 200 | 210 | | |

CORTE DIAGONAL
DIAGONAL CUTTING PLIERS
COUPANTES DIAGONALES
SEITENSCHNEIDER, VERSTÄRKT
TAGLIO LATERALE
ZIKNIPTANG
CORTE DIAGONAL



| COD | L mm | mm | mm | mm |
|-------|------|-----|----|----|
| 62299 | 160 | 210 | 6 | 1 |
| 62350 | 190 | 245 | | |

CORTE DIAGONAL REFORZADO
HEAVY DUTY CUTTING NIPPERS
COUPANTES RENFORCEES
SEITENSCHNEIDER, VERSTÄRKT
TAGLIO LATERALE RINFORZATO
ZIKNIPTANG-VERSTERKT
CORTE DIAGONAL REFORÇADO



| COD | L mm | mm | mm | mm |
|-------|------|-----|----|----|
| 62300 | 180 | 350 | 6 | 1 |
| 62598 | 200 | 375 | | |

CARACTERÍSTICAS

- Sistema de eje desplazado, incrementando la capacidad de corte hasta en un 60% respecto a los alicates tradicionales.
- Corta clavos de hasta 4,5mm de diámetro.
- Eje poligonal extrafuerte para larga duración y suavidad.
- Los alicates universales incorporan una zona de engastar terminales.
- Titacrom®; tratamiento superficial especial, resistente a la corrosión y a los golpes, es antirreflectante y de gran atractivo.
- Mango bicomponente BIMAT ergonómico para un agarre ideal.
- Patentado.

FEATURES

- Displaced joint axle provides high leverage system and 60% more cutting power than standard pliers. Nails of diameter up to 4,5mm.
- Extraresistant polygonal axle pin, long lasting and smooth action.
- Crimping system incorporated in combination pliers for different crimping actions.
- Titcrom® special surface treatment, antirusty, non peel off, non reflecting and attractive finishing.
- Bimat ergonomic two component handle for ideal grip.
- Patented.

CARACTERISTIQUES

- Grâce à un système d'axe déplacé, la capacité de coupe est augmentée de 60% par rapport à une pince traditionnelle.
- Coupe des clous de 4,5mm de diamètre.
- Axe polygonal extrafort longue durée.
- Les pinces universelles incluent la fonction sertissage de terminaux.
- Titacrom® traitement superficiel spécial, résistant à la corrosion et aux coups, anti-réfléchissant et au design attirant.
- Manche bi-matière BIMAT ergonomique pour la meilleure accroche.
- Breveté.

TITACROM BIMAT

TITACROM® BIMAT

UNIVERSALES
COMBINATION
UNIVERSELLES
KOMBIZANGEN
UNIVERSALE
COMBINATIETANG
UNIVERSAIS



DIN 5746

| COD | L | W | W | W |
|-------|-----|-----|---|---|
| 62331 | 165 | 235 | 6 | 1 |
| 62332 | 180 | 275 | | |
| 62333 | 200 | 330 | | |
| 62477 | 210 | 385 | | |

UNIVERSALES CORTE REFORZADO
COMBINATION REINFORCED CUTTING
UNIVERSELLES RENFORCEES
KOMBIZANGEN, VERSTÄRKT
UNIVERSALE RINFORZATA
COMBINATIETANG VERSTERKT
UNIVERSAIS CORTE REFORÇADO



DIN 5746

| | | | | |
|-------|-----|-----|---|---|
| 62334 | 160 | 235 | 6 | 1 |
| 62335 | 180 | 275 | | |
| 62336 | 200 | 330 | | |

BOCA PLANA
FLAT NOSE
PLATES
FLACHZANGEN
BECCHI PIATTI
PLATE TANG
PONTAS CHATAS



DIN 5745

| COD | L | W | W | W |
|-------|-----|-----|---|---|
| 62337 | 160 | 170 | 6 | 1 |

BOCA REDONDA
ROUND NOSE
RONDES
RUNDZANGEN
BECCHI TONDI
TANG MET GEBOGEN BEKKEN
PONTAS REDONDAS



DIN 5745

| COD | L | W | W | W |
|-------|-----|-----|---|---|
| 62338 | 160 | 160 | 6 | 1 |

TELEFONISTA
LONG NOSE
TELEPHONE
TELEFONZANGEN
TELEFONISTI
TELEFOONTANG
TELEFONISTA



DIN 5745

| COD | L | W | W | W |
|-------|-----|-----|---|---|
| 62339 | 160 | 170 | 6 | 1 |
| 62340 | 200 | 210 | | |

TELEFONISTA BOCA CURVA
BENT NOSE PLIERS
TELEPHONE BECS COUDES
TELEFONZANGEN GEBOGEN
TELEFONISTI BECCHI PIEGATI
RADIO TANG MET GEBOGEN BEKKEN
TELEFONISTA PONTAS CURVAS



DIN 5745

| COD | L | W | W | W |
|-------|-----|-----|---|---|
| 62341 | 160 | 170 | 6 | 1 |
| 62342 | 200 | 210 | | |

CORTE DIAGONAL
DIAGONAL CUTTING PLIERS
COUPANTES DIAGONALES
SEITENSCHNEIDER, VERSTÄRKT
TAGLIO LATERALE
ZIKNIPTANG
CORTE DIAGONAL



DIN 5749

| COD | L | W | W | W |
|-------|-----|-----|---|---|
| 62343 | 160 | 210 | 6 | 1 |
| 62540 | 190 | 250 | | |

CORTE DIAGONAL REFORZADO
HEAVY DUTY CUTTING NIPPERS
COUPANTES RENFORCEES
SEITENSCHNEIDER, VERSTÄRKT
TAGLIO LATERALE RINFORZATO
ZIKNIPTANG-VERSTERKT
CORTE DIAGONAL REFORÇADO



DIN 5749

| COD | L | W | W | W |
|-------|-----|-----|---|---|
| 62344 | 180 | 350 | 6 | 1 |
| 62370 | 200 | 375 | | |

CORTE FRONTAL
END CUTTING NIPPER
COUPANTES DEVANT
VORSCHNEIDER
TAGLIO FRONTALE
KOPKNIPTANG
CORTE FRONTAL



DIN 5748

| COD | L | W | W | W |
|-------|-----|-----|---|---|
| 62345 | 160 | 250 | 6 | 1 |

CORTE FRONTAL ELECTRICISTA
END CUTTING NIPPER (ELECTRICIAN)
COUPANTES DEVANT ELECTRICIEN
ELEKTRIKER VORSCHNEIDER
TAGLIO FRONTALE PER ELETTRICISTI
KOPKNIPTANG ELECTRIEKER
CORTE FRONTAL ELECTRICISTA



DIN 5748

| COD | L | W | W | W |
|-------|-----|-----|---|---|
| 62346 | 160 | 250 | 6 | 1 |
| 62347 | 180 | 300 | | |
| 62348 | 200 | 410 | | |

PELACABLES
WIRESTRIPPER
PINCES A DENUDER
ABISOLIERZANGEN
PINZE SPELAFILI
STRIPTANG
DECAPADORES



DIN 5743

| COD | L | W | W | W |
|-------|-----|-----|---|---|
| 62349 | 160 | 170 | 6 | 1 |

1.000V

1.000V
IEC 900 resp.
DIN EN 60 900

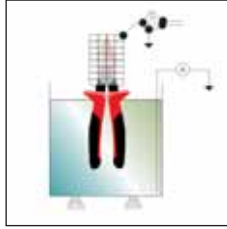

TEST DIELECTRICO A 10.000V
DIELECTRIC TEST AT 10.000V
TEST DIELECTRIQUE A 10.000V
DI-ELEKTRISCHER TEST 10.000V
TEST DIELETTICO A 10.000V
DI-ELECTRISCHE TEST 10.000V
TESTE ELECTRICO 10.000V

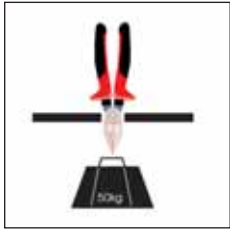

TEST DE ADHERENCIA DE MANGOS
TESTING OF ADHESIVENESS
TEST D'ADHERENCE
KLEBTEST
TEST DI ADERENZA DEI MANICI
KLEEFTEST
TESTE DE ADERÊNCIA DOS CABOS



TEST DE PROPAGACIÓN DE LLAMA
HEAT RESISTANCE TEST
TEST DE COMBUSTIBILITE
BRENNBARKEITS PRÜFUNG
TEST DI DIFFUSIONE DELLA FIAMMA
BRANDBAARHEIDSTEST
TESTE DE PROPAGAÇÃO DE CHAMA

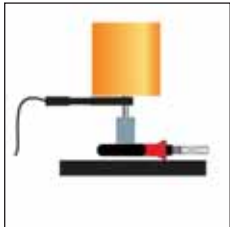

TEST DE PENETRACION
PENETRATION TEST
TEST DE PENETRATION
DI-ELEKTRISCHE PRÜFUNG
PROVA DIELETTICA
DI-ELECTRISCHE TEST
TESTE DE PENETRAÇÃO

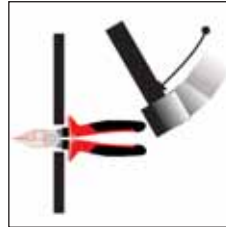

TEST DE IMPACTO
IMPACT TEST
TEST D'IMPACT
SCHLAGBIEGEFESTIGKEIT PRÜFUNG
TEST DI RESA AD IMPATTO
KOUDE RESISTENTIE TEST
TESTE DE IMPACTO

MASTERCUT TITACROM BIMAT 1000V

TITACROM[®] BIMAT

UNIVERSALES
COMBINATION
UNIVERSELLES
KOMBIZANGEN
UNIVERSALE
COMBINATIETANG
UNIVERSAIS

1.000V
IEC 900 resp.
DIN EN 60 900



| COD | | | | |
|-------|-----|-----|---|---|
| 62510 | 160 | 220 | | |
| 62511 | 180 | 230 | | |
| 62512 | 200 | 280 | | |
| 62483 | 210 | 290 | 6 | 1 |
| 62488 | 220 | 310 | | |
| 62484 | 235 | 380 | | |

TELEFONISTA
LONG NOSE
TELEPHONE
TELEFONZANGEN
TELEFONISTI
TELEFOONTANG
TELEFONISTA

1.000V
IEC 900 resp.
DIN EN 60 900



| COD | | | | |
|-------|-----|-----|---|---|
| 62778 | 160 | 170 | | |
| 62779 | 200 | 210 | 6 | 1 |

TELEFONISTA BOCA CURVA
BENT NOSE PLIERS
TELEPHONE BECS COUDES
TELEFONZANGEN GEBOGEN
TELEFONISTI BECCHI PIEGATI
RADIO TANG MET GEBOGEN BEKKEN
TELEFONISTA PONTAS CURVAS

1.000V
IEC 900 resp.
DIN EN 60 900



| COD | | | | |
|-------|-----|-----|---|---|
| 62780 | 160 | 170 | | |
| 62781 | 200 | 210 | 6 | 1 |

CORTE DIAGONAL
DIAGONAL CUTTING PLIERS
COUPANTES DIAGONALES
SEITENSCHNEIDER, VERSTÄRKT
TAGLIO LATERALE
ZIKNIPTANG
CORTE DIAGONAL

1.000V
IEC 900 resp.
DIN EN 60 900



| COD | | | | |
|-------|-----|-----|---|---|
| 62782 | 160 | 210 | | |
| 62783 | 190 | 245 | 6 | 1 |

CORTE DIAGONAL REFORZADO
HEAVY DUTY CUTTING NIPPERS
COUPANTES RENFORCEES
SEITENSCHNEIDER, VERSTÄRKT
TAGLIO LATERALE RINFORZATO
ZIKNIPTANG-VERSTERKT
CORTE DIAGONAL REFORÇADO

1.000V
IEC 900 resp.
DIN EN 60 900



| COD | | | | |
|-------|-----|-----|---|---|
| 62784 | 180 | 350 | | |
| 62599 | 200 | 375 | 6 | 1 |

TITACROM BIMAT 1000V

TITACROM® BIMAT

UNIVERSALES
COMBINATION
UNIVERSELLES
KOMBIZANGEN
UNIVERSALE
COMBINATIETANG
UNIVERSAIS

△1.000V
IEC 900 resp.
DIN EN 60 900



DIN 5746

| COD | | | | |
|-------|-----|-----|---|---|
| 62371 | 165 | 235 | 6 | 1 |
| 62372 | 180 | 275 | | |
| 62373 | 200 | 330 | | |
| 62481 | 210 | 385 | | |

UNIVERSALES CORTE REFORZADO
COMBINATION REINFORCED CUTTING
UNIVERSELLES RENFORCEES
KOMBIZANGEN, VERSTÄRKT
UNIVERSALE RINFORZATA
COMBINATIETANG VERSTERKT
UNIVERSAIS CORTE REFORÇADO

△1.000V
IEC 900 resp.
DIN EN 60 900



DIN 5746

| COD | | | | |
|-------|-----|-----|---|---|
| 62374 | 160 | 250 | 6 | 1 |
| 62375 | 180 | 290 | | |
| 62376 | 200 | 400 | | |

BOCA PLANA
FLAT NOSE
PLATES
FLACHZANGEN
BECCHI PIATTI
PLATE TANG
PONTAS CHATAS

△1.000V
IEC 900 resp.
DIN EN 60 900



DIN 5745

| COD | | | | |
|-------|-----|-----|---|---|
| 62377 | 160 | 170 | 6 | 1 |

BOCA REDONDA
ROUND NOSE
RONDES
RUNDZANGEN
BECCHI TONDI
TANG MET GEBOGEN BEKKEN
PONTAS REDONDAS

△1.000V
IEC 900 resp.
DIN EN 60 900



DIN 5745

| COD | | | | |
|-------|-----|-----|---|---|
| 62378 | 160 | 160 | 6 | 1 |

TELEFONISTA
LONG NOSE
TELEPHONE
TELEFONZANGEN
TELEFONISTI
TELEFOONTANG
TELEFONISTA

△1.000V
IEC 900 resp.
DIN EN 60 900



DIN 5745

| COD | | | | |
|-------|-----|-----|---|---|
| 62379 | 160 | 170 | 6 | 1 |
| 62380 | 200 | 210 | | |

TELEFONISTA BOCA CURVA
BENT NOSE PLIERS
TELEPHONE BECS COUDES
TELEFONZANGEN GEBOGEN
TELEFONISTI BECCHI PIEGATI
RADIO TANG MET GEBOGEN BEKKEN
TELEFONISTA PONTAS CURVAS

△1.000V
IEC 900 resp.
DIN EN 60 900



DIN 5745

| COD | | | | |
|-------|-----|-----|---|---|
| 62381 | 160 | 170 | 6 | 1 |
| 62382 | 200 | 210 | | |

CORTE DIAGONAL
DIAGONAL CUTTING PLIERS
COUPANTES DIAGONALES
SEITENSCHNEIDER, VERSTÄRKT
TAGLIO LATERALE
ZIKNIPTANG
CORTE DIAGONAL

△1.000V
IEC 900 resp.
DIN EN 60 900



DIN 5749

| COD | | | | |
|-------|-----|-----|---|---|
| 62383 | 160 | 210 | 6 | 1 |
| 62600 | 190 | 245 | | |

CORTE DIAGONAL REFORZADO
HEAVY DUTY CUTTING NIPPERS
COUPANTES RENFORCEES
SEITENSCHNEIDER, VERSTÄRKT
TAGLIO LATERALE RINFORZATO
ZIKNIPTANG-VERSTERKT
CORTE DIAGONAL REFORÇADO

△1.000V
IEC 900 resp.
DIN EN 60 900



DIN 5749

| COD | | | | |
|-------|-----|-----|---|---|
| 62384 | 180 | 350 | 6 | 1 |
| 62321 | 200 | 375 | | |

CORTE FRONTAL
END CUTTING NIPPER
COUPANTES DEVANT
VORSCHNEIDER
TAGLIO FRONTALE
KOPKNIPTANG
CORTE FRONTAL

△1.000V
IEC 900 resp.
DIN EN 60 900



DIN 5748

| COD | | | | |
|-------|-----|-----|---|---|
| 62385 | 160 | 250 | 6 | 1 |

CORTE FRONTAL ELECTRICISTA
END CUTTING NIPPER (ELECTRICIAN)
COUPANTES DEVANT ELECTRICIEN
ELEKTRIKER VORSCHNEIDER
TAGLIO FRONTALE PER ELETTRICISTI
KOPKNIPTANG ELECTRIEKER
CORTE FRONTAL ELECTRICISTA

△1.000V
IEC 900 resp.
DIN EN 60 900



DIN 5748

| COD | | | | |
|-------|-----|-----|---|---|
| 62386 | 160 | 250 | 6 | 1 |
| 62387 | 180 | 300 | | |
| 62388 | 200 | 410 | | |

PELACABLES
WIRESTRIPPER
PINCES A DENUDER
ABISOLIERZANGEN
PINZE SPELAFILI
STRIPTANG
DECAPARADORES

△1.000V
IEC 900 resp.
DIN EN 60 900



DIN 5743

| COD | | | | |
|-------|-----|-----|---|---|
| 62389 | 160 | 170 | 6 | 1 |

CROMADO NEGRO / BLACK CHROME PLATING / CHROME NOIR / SCHWARZ VERCHROMT
ZWART VERCHROOMD / BRUNITO / BRUNIDOS

BiMAT

UNIVERSALES
COMBINATION
UNIVERSELLES
KOMBIZANGEN
UNIVERSALE
COMBINATIETANG
UNIVERSAIS



DIN 5746

| COD | L mm | W mm | W mm | W mm |
|-------|------|------|------|------|
| 62391 | 160 | 235 | 6 | 1 |
| 62392 | 180 | 275 | | |
| 62393 | 200 | 330 | | |
| 62408 | 210 | 385 | | |

UNIVERSALES CORTE REFORZADO
COMBINATION REINFORCED CUTTING
UNIVERSELLES RENFORCEES
KOMBIZANGEN, VERSTÄRKT
UNIVERSALE RINFORZATA
COMBINATIETANG VERSTERKT
UNIVERSAIS CORTE REFORÇADO



DIN 5746

| COD | L mm | W mm | W mm | W mm |
|-------|------|------|------|------|
| 62394 | 160 | 235 | 6 | 1 |
| 62395 | 180 | 275 | | |
| 62396 | 200 | 330 | | |

BOCA PLANA
FLAT NOSE
PLATES
FLACHZANGEN
BECCHI PIATTI
PLATE TANG
PONTAS CHATAS



DIN 5745

| COD | L mm | W mm | W mm | W mm |
|-------|------|------|------|------|
| 62397 | 160 | 170 | 6 | 1 |

BOCA REDONDA
ROUND NOSE
RONDES
RUNDZANGEN
BECCHI TONDI
TANG MET GEBOGEN BEKKEN
PONTAS REDONDAS



DIN 5745

| COD | L mm | W mm | W mm | W mm |
|-------|------|------|------|------|
| 62398 | 160 | 160 | 6 | 1 |

TELEFONISTA
LONG NOSE
TELEPHONE
TELEFONZANGEN
TELEFONISTI
TELEFOONTANG
TELEFONISTA



DIN 5745

| COD | L mm | W mm | W mm | W mm |
|-------|------|------|------|------|
| 62399 | 160 | 170 | 6 | 1 |
| 62400 | 200 | 210 | | |

TELEFONISTA BOCA CURVA
BENT NOSE PLIERS
TELEPHONE BECS COUDES
TELEFONZANGEN GEBOGEN
TELEFONISTI BECCHI PIEGATI
RADIO TANG MET GEBOGEN BEKKEN
TELEFONISTA PONTAS CURVAS



DIN 5745

| COD | L mm | W mm | W mm | W mm |
|-------|------|------|------|------|
| 62401 | 160 | 170 | 6 | 1 |
| 62402 | 200 | 210 | | |

CORTE DIAGONAL
DIAGONAL CUTTING PLIERS
COUPANTES DIAGONALES
SEITENSCHNEIDER, VERSTÄRKT
TAGLIO LATERALE
ZIKNIPTANG
CORTE DIAGONAL



DIN 5749

| COD | L mm | W mm | W mm | W mm |
|-------|------|------|------|------|
| 62403 | 160 | 210 | 6 | 1 |

CORTE DIAGONAL REFORZADO
HEAVY DUTY CUTTING NIPPERS
COUPANTES RENFORCEES
SEITENSCHNEIDER, VERSTÄRKT
TAGLIO LATERALE RINFORZATO
ZIKNIPTANG-VERSTERKT
CORTE DIAGONAL REFORÇADO



DIN 5749

| COD | L mm | W mm | W mm | W mm |
|-------|------|------|------|------|
| 62404 | 180 | 350 | 6 | 1 |

PELACABLES
WIRESSTRIPPER
PINCES A DENUDER
ABISOLIERZANGEN
PINZE SPELAFILI
STRIPTANG
DECAPADORES



DIN 5743

| COD | L mm | W mm | W mm | W mm |
|-------|------|------|------|------|
| 62405 | 160 | 170 | 6 | 1 |



ALICATES / PLIERS / PINCES / ZANGEN / PINZE / UITVOERING / ALICATES

PULIDOS / POLISHED / POLIE / POLIERT / FINITURA LUCIDA / GEPOLIJST / POLIDOS

BMAT

UNIVERSALES
COMBINATION
UNIVERSELLES
KOMBIZANGEN
UNIVERSALE
COMBINATIETANG
UNIVERSAIS



DIN 5745

| COD | L mm | | | |
|-------|---------|-----|---|---|
| 62450 | 160 | 235 | 6 | 1 |
| 62451 | 180 | 275 | | |
| 62452 | 200 | 330 | | |
| 62462 | 210 | 385 | | |

BOCA PLANA
FLAT NOSE
PLATES
FLACHZANGEN
BECCHI PIATTI
PLATE TANG
PONTAS CHATAS



DIN 5745

| COD | L mm | | | |
|-------|---------|-----|---|---|
| 62453 | 160 | 150 | 6 | 1 |

BOCA REDONDA
ROUND NOSE
RONDES
RUNDZANGEN
BECCHI TONDI
TANG MET GEBOGEN BEKKEN
PONTAS REDONDAS



DIN 5745

| COD | L mm | | | |
|-------|---------|-----|---|---|
| 62454 | 160 | 140 | 6 | 1 |

TELEFONISTA
LONG NOSE
TELEPHONE
TELEFONZANGEN
TELEFONISTI
TELEFOONTANG
TELEFONISTA



DIN 5745

| COD | L mm | | | |
|-------|---------|-----|---|---|
| 62455 | 160 | 150 | 6 | 1 |
| 62456 | 200 | 190 | | |

TELEFONISTA BOCA CURVA
BENT NOSE PLIERS
TELEPHONE BECS COUDES
TELEFONZANGEN GEBOGEN
TELEFONISTI BECCHI PIEGATI
RADIO TANG MET GEBOGEN BEKKEN
TELEFONISTA PONTAS CURVAS



DIN 5745

| COD | L mm | | | |
|-------|---------|-----|---|---|
| 62457 | 160 | 150 | 6 | 1 |
| 62458 | 200 | 190 | | |

CORTE DIAGONAL
DIAGONAL CUTTING PLIERS
COUPANTES DIAGONALES
SEITENSCHNEIDER, VERSTÄRKT
TAGLIO LATERALE
ZIKNIPTANG
CORTE DIAGONAL



DIN 5749

| COD | L mm | | | |
|-------|---------|-----|---|---|
| 62459 | 160 | 210 | 6 | 1 |

CORTE DIAGONAL REFORZADO
HEAVY DUTY CUTTING NIPPERS
COUPANTES RENFORCEES
SEITENSCHNEIDER, VERSTÄRKT
TAGLIO LATERALE RINFORZATO
ZIKNIPTANG-VERSTERKT
CORTE DIAGONAL REFORÇADO



DIN 5749

| COD | L mm | | | |
|-------|---------|-----|---|---|
| 62460 | 180 | 350 | 6 | 1 |

PELACABLES
WIRESSTRIPPER
PINCES A DENUDER
ABISOLIERZANGEN
PINZE SPELAFILI
STRIPTANG
DECAPADORES



DIN 5743

| COD | L mm | | | |
|-------|---------|-----|---|---|
| 62461 | 160 | 150 | 6 | 1 |

UNIVERSAL MOD. ELECTRICISTA
LINESMAN'S
ELECTRICIEN
KOMBIZANGEN
UNIVERSALE MOD. PER ELETTRICISTI
COMBINATIETANG ELECTRIEKER
UNIVERSAL MOD. ELECTRICISTA



| COD | L mm | | | |
|-------|---------|-----|---|---|
| 62074 | 250 | 475 | 6 | 1 |

ALICATES CIRCLIPS / CIRCLIPS PLIERS / PINCES POUR CIRCLIPS / ZANGEN FÜR SICHERUNGSRINGE / PINZE PER ANELLI / BORGVEERTANGEN / ALICATES FREIOS

PAVONADO / BLACK FINISHED / BRUNIE / BRÜNIERT / BRUNITO / ZWARTE / BRUNIDO



EXTERIOR RECTO
EXTERNAL STRAIGHT
EXTERIEUR DROIT
AUSSENSICHERUNGSRINGE, GERADE
DIRITTO PER ANELLI
BUITEN-RECHTE BEKKEN
EXTERIOR DIREITO



DIN 5254

| COD | L mm | mm | mm | | |
|-------|------|--------|-----|---|---|
| 62214 | | 3÷10 | 100 | | |
| 62215 | 150 | 10÷25 | 100 | | |
| 62183 | 180 | 19÷60 | 150 | 6 | 1 |
| 62216 | 230 | 40÷100 | 265 | | |
| 62217 | 320 | 85÷200 | 525 | | |

EXTERIOR CURVO
EXTERNAL BENT
EXTERIEUR COUDE
BACKEN UM 90 GEBOGEN
PIEGATO PER ESTERNI
BUITEN-GEBOGEN BEKKEN
EXTERIOR CURVO



DIN 5254

| COD | L mm | mm | mm | | |
|-------|------|--------|-----|---|---|
| 62218 | | 3÷10 | 100 | | |
| 62219 | 150 | 10÷25 | 100 | | |
| 62182 | 170 | 19÷60 | 150 | 6 | 1 |
| 62220 | 210 | 40÷100 | 265 | | |
| 62221 | 305 | 85÷200 | 525 | | |

INTERIOR RECTO
INTERNAL STRAIGHT
INTERIEUR DROIT
INNENSICHERUNGSRINGE, GERADE
DIRITTO PER INTERNI
BINNEN-RECHTE BEKKEN
INTERIOR DIREITO



DIN 5256

| COD | L mm | mm | mm | | |
|-------|------|--------|-----|---|---|
| 62222 | | 8÷13 | 100 | | |
| 62223 | 150 | 12÷25 | 100 | | |
| 62181 | 180 | 19÷60 | 150 | 6 | 1 |
| 62224 | 220 | 40÷100 | 265 | | |
| 62225 | 320 | 85÷200 | 525 | | |

INTERIOR CURVO
INTERNAL BENT
INTERIEUR COUDE
BACKEN UM 90 GEBOGEN
PIEGATO PER INTERNI
BINNEN-GEBOGEN BEKKEN
INTERIOR CURVO



DIN 5256

| COD | L mm | mm | mm | | |
|-------|------|--------|-----|---|---|
| 62226 | | 8÷13 | 100 | | |
| 62227 | 150 | 12÷25 | 100 | | |
| 62180 | 170 | 19÷60 | 150 | 6 | 1 |
| 62228 | 210 | 40÷100 | 265 | | |
| 62229 | 305 | 85÷200 | 525 | | |

MULTI CIRCLIPS

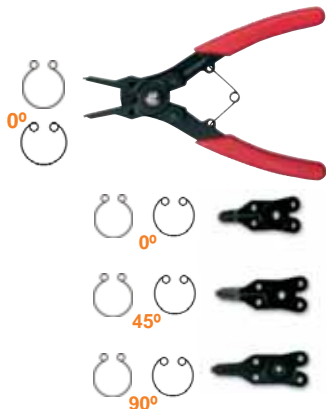

| COD | L mm | mm | mm | | |
|-------|------|-------|-----|---|---|
| 62213 | 160 | 10-50 | 200 | 6 | 1 |

ALICATES / PLIERS / PINCES / ZANGEN / PINZE / UITVOERING / ALICATES

MINIS PARA ELECTRONICA / ELECTRONIC PLIERS / PINCES ELECTRONIQUES
ELEKTRONIK-ZANGEN / PINZE PER ELETTRONICA / ELEKTRONICA TANGENTITACROM® **BMAT**UNIVERSALES
COMBINATION
UNIVERSELLES
KOMBIZANGEN
UNIVERSALE
COMBINATIETANG
UNIVERSAIS

DIN 9655

| COD |  |  |  |  |
|-------|---|---|---|---|
| 62241 | 125 | 65 | 12 | 1 |



BOCA PLANA
FLAT NOSE
PLATES
FLACHZANGEN
BECCHI PIATTI
PLATE TANG
PONTAS CHATAS

DIN 9655

| COD |  |  |  |  |
|-------|---|---|---|---|
| 62242 | 125 | 50 | 12 | 1 |





BOCA REDONDA
ROUND NOSE
RONDES
RUNDZANGEN
BECCHI TONDI
TANG MET GEBOGEN BEKKEN
PONTAS REDONDAS

DIN 9655

| COD |  |  |  |  |
|-------|---|---|---|---|
| 62243 | 125 | 50 | 12 | 1 |





TELEFONISTA
LONG NOSE
TELEPHONE
TELEFONZANGEN
TELEFONISTI
TELEFOONTANG
TELEFONISTA

DIN 9655

| COD |  |  |  |  |
|-------|--|--|--|--|
| 62244 | 125 | 50 | 12 | 1 |

TELEFONISTA BOCA CURVA
BENT NOSE PLIERS
TELEPHONE BECS COUDES
TELEFONZANGEN GEBOGEN
TELEFONISTI BECCHI PIEGATI
RADIO TANG MET GEBOGEN BEKKEN
TELEFONISTA PONTAS CURVAS

DIN 9655

| COD |  |  |  |  |
|-------|---|---|---|---|
| 62245 | 125 | 50 | 12 | 1 |



BOCA AGUJA
LONG NEEDLE NOSE
LONG BECS DEMI-RONDS
FLACHZANGE MIT LANGEM MAUL
BECHI TONDI AFFUSOLATI
TANG MET HALF-RONDE BEKKEN, EXTRA LANG
PONTAS AGULHA

DIN 9655

| COD |  |  |  |  |
|-------|---|---|---|---|
| 62246 | 150 | 60 | 12 | 1 |

CORTE DIAGONAL
DIAGONAL CUTTING PLIERS
COUPANTES DIAGONALES
SEITENSCHNEIDER, VERSTÄRKT
TAGLIO LATERALE
ZIKNIPTANG
CORTE DIAGONAL

DIN 9654

| COD |  |  |  |  |
|-------|---|---|---|---|
| 62247 | 115 | 55 | 12 | 1 |

CORTE DIAGONAL TRIANGULAR
DIAGONAL CUTTING TRIANGULAR
COUPANTES DIAGONALE TRIANGULAIRE
SEITENSCHNEIDER
TAGLIO LATERALE TRIANGOLARE
ZIJKNIPTANG DIAGONAL
CORTE DIAGONAL TRIANGULAR

DIN 9654

| COD |  |  |  |  |
|-------|---|---|---|---|
| 62248 | 115 | 45 | 12 | 1 |

CORTE FRONTAL
END CUTTING NIPPER
COUPANTES DEVANT
VORN SCHNEIDER
TAGLIO FRONTALE
KOPKNIPTANG
CORTE FRONTAL

DIN 9654

| COD |  |  |  |  |
|-------|---|---|---|---|
| 62249 | 110 | 55 | 12 | 1 |

MINIS PARA ELECTRONICA / ELECTRONIC PLIERS / PINCES ELECTRONIQUES
ELEKTRONISK-ZANGEN / PINZE PER ELETTRONICA / ELEKTRONICA TANGENCROMADO NEGRO / BLACK CHROME PLATING / CHROMÉE NOIR / SCHWARZ VERCHROMT / ZWART VERCHROOMD
BRUNITO / BRUNIDOS**BITAT**UNIVERSALES
COMBINATION
UNIVERSELLES
KOMBIZANGEN
UNIVERSALE
COMBINATIETANG
UNIVERSAIS

DIN 9655



COD

62523

L

125



65



12



1

BOCA PLANA
FLAT NOSE
PLATES
FLACHZANGEN
BECCHI PIATTI
PLATE TANG
PONTAS CHATAS

DIN 9655



COD

62524

L

125



50



12



1

BOCA REDONDA
ROUND NOSE
RONDES
RUNDZANGEN
BECCHI TONDI
TANG MET GEBOGEN BEKKEN
PONTAS REDONDAS

DIN 9655



COD

62525

L

125



50



12



1

TELEFONISTA
LONG NOSE
TELEPHONE
TELEFONZANGEN
TELEFONISTI
TELEFOONTANG
TELEFONISTA

DIN 9655



COD

62526

L

125



50



12



1

TELEFONISTA BOCA CURVA
BENT NOSE PLIERS
TELEPHONE BECS COUDES
TELEFONZANGEN GEBOGEN
TELEFONISTI BECCHI PIEGATI
RADIO TANG MET GEBOGEN BEKKEN
TELEFONISTA PONTAS CURVAS

DIN 9655



COD

62527

L

125



50



12



1

BOCA AGUJA
LONG NEEDLE NOSE
LONG BECS DEMI-RONDS
FLACHZANGE MIT LANGEM MAUL
BECCHI TONDI AFFUSOLATI
TANG MET HALF-RONDE BEKKEN, EXTRA LANG
PONTAS AGULHA

DIN 9655



COD

62528

L

150



60



12



1

CORTE DIAGONAL
DIAGONAL CUTTING PLIERS
COUPANTES DIAGONALES
SEITENSCHNEIDER, VERSTÄRKT
TAGLIO LATERALE
ZIKNIPTANG
CORTE DIAGONAL

DIN 9654



COD

62529

L

115



55



12



1

CORTE DIAGONAL TRIANGULAR
DIAGONAL CUTTING TRIANGULAR
COUPANTES DIAGONALE TRIANGULAIRE
SEITENSCHNEIDER
TAGLIO LATERALE TRIANGOLARE
ZIKNIPTANG DIAGONAL
CORTE DIAGONAL TRIANGULAR

DIN 9654



COD

62530

L

115



45



12



1

CORTE FRONTAL
END CUTTING NIPPER
COUPANTES DEVANT
VORN SCHNEIDER
TAGLIO FRONTALE
KOPKNIPTANG
CORTE FRONTAL

DIN 9654



COD

62531

L

110



55



12



1



EXPOSITORES / DISPLAYS / PRESENTOIRS / STÄNDER / ESPOSITORE / DISPLAY STAND

BMAT



| UN. | COD. 62330 | |
|-----|------------|-------|
| 3 | 62331 | 160mm |
| | 62332 | 180mm |
| | 62333 | 200mm |
| | 62337 | |
| | 62338 | 160mm |
| | 62339 | |
| | 62340 | 200mm |
| | 62341 | 160mm |
| | 62342 | 200mm |
| | 62343 | 160mm |
| | 62344 | 180mm |
| | 62345 | 160mm |

TITACROM®

| UN. | COD. 62410 | |
|-----|------------|-------|
| 3 | 62391 | 160mm |
| | 62392 | 180mm |
| | 62393 | 200mm |
| | 62397 | |
| | 62398 | 160mm |
| | 62399 | |
| | 62400 | 200mm |
| | 62401 | 160mm |
| | 62402 | 200mm |
| | 62403 | 160mm |
| | 62404 | 180mm |
| | 62395 | 180mm |

CROMADO NEGRO
BLACK CHROME PLATING
CHROME NOIR

| UN. | COD. 62040 | |
|-----|------------|-------|
| 3 | 62450 | 160mm |
| | 62451 | 180mm |
| | 62452 | 200mm |
| | 62453 | |
| | 62454 | 160mm |
| | 62455 | |
| | 62456 | 200mm |
| | 62457 | 160mm |
| | 62458 | 200mm |
| | 62459 | 160mm |
| | 62460 | 180mm |
| | 62461 | 160mm |

PULIDOS
POLISHED
POLIE

BMAT



| UN. | COD. 62265 | |
|-----|------------|-------|
| 6 | 62241 | |
| | 62242 | |
| 3 | 62243 | 125mm |
| | 62244 | |
| | 62245 | |
| 6 | 62246 | 150mm |
| | 62247 | 115mm |
| 3 | 62248 | 115mm |
| | 62249 | 110mm |

TITACROM®

| UN. | COD. 62535 | |
|-----|------------|-------|
| 6 | 62523 | |
| | 62524 | |
| 3 | 62525 | 125mm |
| | 62526 | |
| | 62527 | |
| 6 | 62528 | 150mm |
| | 62529 | 115mm |
| 3 | 62530 | 115mm |
| | 62531 | 110mm |

CROMADO NEGRO
BLACK CHROME PLATING
CHROME NOIR

KITS **BIMAT**

| UN. | COD A: 69365 COD B: 68475 | |
|-----|------------------------------|-------|
| | 62332 | 180mm |
| 1 | 62343 | 160mm |
| | 62349 | 160mm |

TITACROM®

| UN. | COD A: 69368 COD B: 68479 | |
|-----|------------------------------|-------|
| | 62392 | 180mm |
| 1 | 62403 | 160mm |
| | 62405 | 160mm |

CROMADO NEGRO
BLACK CHROME PLATING
CHROME NOIR

| UN. | COD A: 69367 COD B: 68483 | |
|-----|------------------------------|-------|
| | 62451 | 180mm |
| 1 | 62459 | 160mm |
| | 62461 | 160mm |

PULIDOS
POLISHED
POLIE



A

NEW



B



| UN. | COD A: 69370 COD B: 68476 | |
|-----|------------------------------|-------|
| | 62332 | 180mm |
| 1 | 62343 | 160mm |
| | 62446 | 250mm |

TITACROM®

| UN. | COD A: 69373 COD B: 68480 | |
|-----|------------------------------|-------|
| | 62392 | 180mm |
| 1 | 62403 | 160mm |
| | 62446 | 250mm |

CROMADO NEGRO
BLACK CHROME PLATING
CHROME NOIR

| UN. | COD A: 69372 COD B: 68484 | |
|-----|------------------------------|-------|
| | 62451 | 180mm |
| 1 | 62459 | 160mm |
| | 62446 | 250mm |

PULIDOS
POLISHED
POLIE



A

NEW



B



| UN. | COD A: 69375 COD B: 68477 | |
|-----|------------------------------|-------|
| | 62332 | 180mm |
| 1 | 62343 | 160mm |
| | 62340 | 200mm |

TITACROM®

| UN. | COD A: 69378 COD B: 68481 | |
|-----|------------------------------|-------|
| | 62392 | 180mm |
| 1 | 62403 | 160mm |
| | 62400 | 200mm |

CROMADO NEGRO
BLACK CHROME PLATING
CHROME NOIR

| UN. | COD A: 69377 COD B: 68485 | |
|-----|------------------------------|-------|
| | 62451 | 180mm |
| 1 | 62459 | 160mm |
| | 62456 | 200mm |

PULIDOS
POLISHED
POLIE



A

NEW



B



| UN. | COD A: 69380 COD B: 68478 | |
|-----|------------------------------|-------|
| | 62332 | 180mm |
| 1 | 62343 | 160mm |
| | 62143 | 250mm |

TITACROM®

| UN. | COD A: 69383 COD B: 68482 | |
|-----|------------------------------|-------|
| | 62392 | 180mm |
| 1 | 62403 | 160mm |
| | 62143 | 250mm |

CROMADO NEGRO
BLACK CHROME PLATING
CHROME NOIR

| UN. | COD A: 69382 COD B: 68486 | |
|-----|------------------------------|-------|
| | 62451 | 180mm |
| 1 | 62459 | 160mm |
| | 62143 | 250mm |

PULIDOS
POLISHED
POLIE



A

NEW



B



BMAAT



| UN. | COD. 69434 | |
|-----|------------|-------|
| 1 | 62249 | 110mm |
| | 62241 | 125mm |
| | 62247 | 115mm |

TITACROM®



| UN. | COD. 69495 | |
|-----|------------|-------|
| 1 | 62531 | 110mm |
| | 62523 | 125mm |
| | 62529 | 115mm |

CROMADO NEGRO
BLACK CHROME PLATING
CHROME NOIR



| UN. | COD. 69433 | |
|-----|------------|-------|
| 1 | 62244 | 125mm |
| | 62245 | |
| | 62246 | 150mm |
| | 62247 | 115mm |
| | 62249 | 110mm |
| | 66846 | 50x2 |
| | 66850 | PH-00 |
| | 69530 | - |

TITACROM®



| UN. | COD. 69496 | |
|-----|------------|-------|
| 1 | 62526 | 125mm |
| | 62527 | |
| | 62528 | 150mm |
| | 62529 | 115mm |
| | 62531 | 110mm |
| | 66846 | 50x2 |
| | 66850 | PH-00 |
| | 69530 | - |

CROMADO NEGRO
BLACK CHROME PLATING
CHROME NOIR

EGA Master S.A.
ART IN INNOVATION



PARA TERMINALES AISLADOS / FOR INSULATED TERMINALS / POUR TERMINAUX ISOLES / FÜR ISOLIERTE KABELSCHUHE
VOOR GEISOLIEERTE TERMINALS / PER TERMINALI ISOLATI / PARA TERMINAIS ISOLADOS

| COD | L mm | CAP. mm ² | | | |
|-------|---------|-------------------------|-----|---|---|
| 62493 | 200 | 0,75-6 | 175 | 6 | 1 |



PARA UNION DE CABLES AISLADOS Y NO AISLADOS / FOR CABLE LINKS INSULATED & NO INSULATED / POUR UNION DE
CABLES ISOLES ET NON ISOLES / FÜR ISOLIERTE UND NICHT ISOLIERTE KABELSCHUHE / VOOR GEISOLIEERTE EN NIET GEI-
SOLEERDE TERMINALS / PER UNIRE CAVI ISOLATI E NON ISOLATI / PARA UNIÃO DE CABOS ISOLADOS E Não ISOLADOS

| COD | L mm | CAP. mm ² | | | |
|-------|---------|-------------------------|-----|---|---|
| 62494 | 220 | 0,75-6 | 190 | 6 | 1 |



PARA TERMINALES AISLADOS / FOR INSULATED TERMINALS / POUR TERMINAUX ISOLES / FÜR ISOLIERTE KABELSCHUHE
VOOR GEISOLIEERTE TERMINALS / PER TERMINALI ISOLATI / PARA TERMINAIS ISOLADOS

| COD | L mm | DIN mm ² | AWG | | |
|-------|---------|------------------------|-------|-----|---|
| 62591 | 9" | 0,5-6 | 22-10 | 540 | 6 |



PARA UNION DE CABLES AISLADOS Y NO AISLADOS / FOR CABLE LINKS INSULATED & NO INSULATED / POUR UNION DE
CABLES ISOLES ET NON ISOLES / FÜR ISOLIERTE UND NICHT ISOLIERTE KABELSCHUHE / VOOR GEISOLIEERTE EN NIET
GEISOLEERDE TERMINALS / PER UNIRE CAVI ISOLATI E NON ISOLATI / PARA UNIÃO DE CABOS ISOLADOS E Não ISOLADOS

| COD | L mm | DIN mm ² | AWG | | |
|-------|---------|------------------------|-------|-----|---|
| 62594 | 7.1/2" | 0,14-2,5 | 26-14 | 360 | 6 |



PARA TERMINALES NO AISLADOS / FOR NOT INSULATED TERMINALS / POUR TERMINAUX NON ISOLES / FÜR NICHT ISOLIERTE
KABELSCHUHE / VOOR NIET GEISOLIEERTE TERMINALS / PER TERMINALI NON ISOLATI / PARA TERMINAIS Não ISOLADOS

| COD | L mm | DIN mm ² | AWG | | |
|-------|---------|------------------------|-------|-----|---|
| 62593 | 7.1/2" | 0,5-2,5 | 20-14 | 345 | 6 |



3 *ELECTRICIDAD / ELECTRICIAN TOOLS / OUTILLAGE D'ELECTRICIEN / ELEKTRIK ELECTRICIENSMES / FERRAMENTI PER ELETTRICISTI / ELECTRICIDADE*



PARA TERMINALES AISLADOS DE COLORES / FOR COLOR INSULATED TERMINALS / POUR TERMINAUX ISOLES DE COULEUR
 ABISOLIERWERKZEUG FÜR FARBISOLIERTE KABELSCHUHE / VOOR KLEURGEISOLEERDE TERMINALS / PER TERMINALI ISOLATI
 COLORATI / PARA TERMINAIS ISOLADOS DE CORES

| COD | L | DIN mm² | AWG | | | |
|-------|--------|-------------------------------|----------------------|-----|---|---|
| 62592 | 7.1/2" | 0,25-0,5 0,75-1,5 2-2,5 | 24-20 18-16 14 | 350 | 6 | 1 |



ALICATES PARA CONECTORES COAX-BNC-TNC / FOR COAX-BNC-TNC CONNECTORS / POUR CONNECTEURS COAX-BNC-TNC
 ABISOLIERWERKZEUG FÜR COAX-BNC-TNC VERBINDER / VOOR COAX-BNC-TNC KABELSCHOENEN / PER CONNETTORI COAX-
 BNC-TNC / PARA CONECTORES COAXIAIS BNC-TNC

| COD | L | CAP | | | |
|-------|----|--|-----|---|---|
| 62597 | 9" | 58,59,62,8X, 140,141,174, 210,223,303,400 FIBER OPTIC BELDEN 8279 | 550 | 6 | 1 |



PARA TERMINALES DE TELEFONO / FOR PHONE TERMINALS / POUR TERMINAUX TELEPHONIQUES / ABISOLIERWERKZEUG FÜR
 TELEFONKABEL VOOR TELEFOON TERMINALS / PER TERMINALE TELEFONISTI / PARA TERMINAIS DE TELEFONE

| COD | L | CAP | | | |
|-------|----|--|-----|---|---|
| 62595 | 8" | 4P2C, 4P4C, 6P4C (RJ-11) 6P6C (RJ-12) 8P8C, 10P6C, 10P8C (RJ-45) | 510 | 6 | 1 |



PARA TERMINALES DE TELEFONO / FOR PHONE TERMINALS / POUR TERMINAUX TELEPHONIQUES / ABISOLIERWERKZEUG FÜR
 TELEFONKABEL VOOR TELEFOON TERMINALS / PER TERMINALE TELEFONISTI / PARA TERMINAIS DE TELEFONE



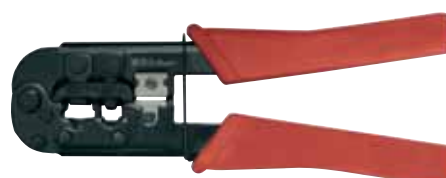

| COD | L | CAP | | | |
|-------|--------|------------------------------------|-----|---|---|
| 62596 | 7.1/2" | 6P4C, 6P6C (RJ-11) 8P8C (RJ-45) | 260 | 6 | 1 |



3

ELECTRICIDAD / ELECTRICIAN TOOLS / OUTILLAGE D'ELECTRICIEN / ELEKTRIK ELECTRICIENSMEŠ / FERRAMENTI PER ELETTRICISTI / ELECTRICIDADE

TIJERA ELECTRICISTA / ELECTRICIAN'S SCISSORS / CISEAUX D'ELECTRICIEN / ELEKTRIKERSCHERE / ELECTRICIENSMEŠ FORBICI PER ELETTRICISTI / TESOURA ELECTRICISTA

| COD |  |  |  |  |
|----------|---|---|---|---|
| A- 69534 | 145 | 100 | 6 | 1 |
| B- 69535 | | 105 | | |

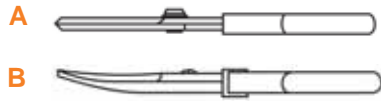

CORTACABLES DE CARRACA / RATCHET ELECTRICIAN CABLE CUTTER / COUPE-CABLES A CLIQUETS / KABELSCHNEIDER MIT RATSCHEN / KABELSNIJDER MET RATEL / TAGLIACAVI CRICCO PER ELETTRICI / CORTA CABOS DE ROQUETE PARA ELECTRICISTA

| COD |  |  |  |  |
|-------|---|---|---|---|
| 62538 | 255 | 32 | 610 | 6 |







TENAZAS CORTACABLES / CABLE CUTTERS / COUPE-CABLES / KABELSCHNEIDER / CESOIE PER CAVI / KABELSNIJDERS TESOURAS CORTA CABOS

| COD |  |  |  |  |  |
|-------|---|---|---|---|---|
| 62151 | 220 mm / 9" inch. | 12 | 390 | 6 | 1 |

Para cobre y aluminio / For copper & aluminium / Pour cuivre et aluminium



| COD |  |  |  |  |  |
|-------|---|---|---|---|---|
| 62164 | 600 mm / 24" inch. | 10 | 455 | 1 | - |

Para cobre y aluminio / For copper & aluminium / Pour cuivre et aluminium



| COD |  |
|-------|---|
| 64055 | 24 |

PINZAS / TWEEZERS / BRUCELLES / GREIFPINZETTEN / PINZETTE DI PRECISIONE / PINCETTEN / PINÇAS
ACERO INOXIDABLE / STAINLESS STEEL / INOX / ACCIAIO INOX / AÇO INOXIDAVEL

| | | | | |
|------------|-----|----|----|---|
| COD | | | | |
| 69530 | 115 | 15 | 12 | 1 |

| | | | | |
|------------|-----|----|----|---|
| COD | | | | |
| 69532 | 120 | 15 | 12 | 1 |

| | | | | |
|------------|-----|----|----|---|
| COD | | | | |
| 69533 | 110 | 15 | 12 | 1 |

| | | | | |
|------------|-----|----|----|---|
| COD | | | | |
| 69531 | 120 | 15 | 12 | 1 |



SET-4 (69530-69531-69532-69533)

| | | | |
|------------|----|----|---|
| COD | | | |
| 69529 | 70 | 12 | 1 |



NAVAJA / PENKNIFE / CANIF / TASCHENMESSER / ZAKMES / COLTELLI / NAVALHA

| | | | | |
|------------|----|-----|----|----|
| COD | | | | |
| 69528 | 85 | 100 | 50 | 12 |
| 69527 | 72 | 85 | 40 | |



| | | | | |
|------------|----|-----|----|----|
| COD | | | | |
| 69525 | 88 | 110 | 70 | 12 |



| | | | | |
|------------|----|-----|----|----|
| COD | | | | |
| 69526 | 73 | 120 | 70 | 12 |



| | | | | | |
|------------|----|----|-----|-----|---|
| COD | | | | | |
| 69591 | 90 | 80 | 115 | 180 | 1 |



SOLDADOR CILINDRICO / SOLDERING IRON / SOUDEUR Á L'ÉTAIN / LÖTKOLBEN / SALDATORE STAGNO / SOLDEERBOUT
SOLDADOR ESTANHADOR

| COD | V | W | °C | | | | |
|-------|-----|----|-----|--|------|--|---|
| 63252 | 230 | 30 | 300 | | Euro | | 1 |
| 63253 | | 40 | 350 | | | | |
| 63254 | | 60 | 380 | | | | |



PISTOLA PARA SOLDAR / SOLDERING IRON GUN / PISTOLET Á SOUDER / LÖTPISTOLE / PISTOLA PER SALDARE
SOLDEERPISTOOL / PISTOLA DE SOLDAR

| COD | V | W | °C | | | |
|-------|-----|----|-----|------|----|---|
| 63255 | 230 | 60 | 380 | Euro | 75 | 1 |

A: Con alimentador / With feeder / Avec alimentateur



| COD | V | W | Hz | Incluye / Included | | |
|-------|-----|-----|----|--|------|----------------------------|
| 63268 | 230 | 100 | 50 | 1 punta / 1 tip INOX | 700 | Blister |
| 63269 | | | | 3 puntas / 3 tips INOX Rollo estañar / Soldering roil Pasta decapante / Flux | 1000 | Estuche Plastic case |

Longitud de cable / Length of cable: 1,8m



DESOLDADOR CON BOQUILLA ANTIESTÁTICA / DESOLDERING PUMP WITH ANTI-STATIC RUBBER NOZZLE / PISTOLET Á COLLE / ABLÖTPUMPE MIT ANTI-STATIC GUMMI SPITZE / POMPETTA PER DISSALDARE / TINZUIGPOMP MET ANTISTATISCHE GUMMI TIP / CHUPA SOLDAS COM BORRACHA ANTI-ESTÁTICA PARA SOLDADURA

| COD | | | | |
|-------|-----|---|----|------|
| 63256 | 170 | 5 | 55 | Euro |



SOPORTE PARA SOLDADOR DE ESTAÑO / BASE FOR SOLDERING IRON / SUPPORT POUR SOUDEUR A L'ÉTAIN / LÖTKOLBEN HALTER / SUPPORTO PER SALDATORE STAGNO SOLDEERBOUHOUDER / SUPORTE PARA SOLDADOR DE ESTANHO

| COD | | |
|-------|-----|---|
| 63257 | 250 | 1 |



ROLLO DE ESTAÑO PARA SOLDAR / SOLDERING ROLL / ROULEAU D'ÉTAIN Á SOUDER / LÖTDRHAHT ROCCHETTO DI STAGNO PER SALDARE / SOLDEERDRAAD / ROLO DE ESTANHO PARA SOLDAR

| COD | %Sn | %Pb | | |
|-------|-----|-----|-----|---|
| 63258 | 35 | 65 | 900 | 1 |
| 63259 | 60 | 40 | 500 | |



CORTACABLES PARA TALADRO / WIRE CUTTER FOR DRILL / COUPE CÂBLE POURPERCEUSE
DRAHTSCHNEIDER FÜR BOHRMASCHINE / TAGLIACAVI PER TRAPANODRAADSNIJDER VOOR
BOORMACHINE / CORTA CABOS PARA BERBEQUIM



| COD | CAP (mm) | | | Kg |
|-------|----------|-------|---|-----|
| 60135 | 30 | 84405 | | 2,8 |
| 60136 | 33 | 84406 | | 2,9 |
| 60137 | 35 | 84407 | | 2,9 |
| 60138 | 53 | 84408 | 1 | 3,2 |
| 60145 | 55 | 84409 | | 3,3 |
| 60146 | 80 | 84410 | | 3,8 |
| 60147 | 100 | 84411 | | 4 |

Especificaciones técnicas / Technical specification / Détails techniques

| | |
|---|---|
| Acero especial para corte de materiales metálicos / Special steel for cutting metallic materials Acier spécial de coupe pour matériaux métalliques | ● |
| Apropiado para cualquier taladro estándar / Suitable to be used with any standard drill Approprié pour toutes perceuses standarts | ● |
| Estuche aluminio / Aluminium case / Etui aluminium | ● |
| Uso seguro, cómodo y eficaz / Safe, comfortable and effective Utilisation sûre, commode et efficace | ● |



COBRE
COPPER
CUIVRE



ALUMINIO
ALUMINIUM
ALUMINIUM



COBRE MULTIPLE
MULTI-COPPER
CUIVRE MULTIPLE



CABLE ACERO
STEEL WIRE ROPE
CÂBLE ACIER



CABLE ACERO RECUBIERTO
COATED STEEL WIRE ROPE
CÂBLE ACIER GAINÉ



CADENA
CHAIN
CHAÎNE

Consultar diámetros y características de corte orientativos en página siguiente / Check guidance on diameters and cutting specifications in next page / Voir les diamètres et caractéristiques de coupe orientatifs dans la page suivante



Valores máximos de corte / Cutting maximum values / Valeurs maximum de coupe

| COD |  Cu |  Al |  Acero/Steel |  Acero/Steel |  Acero/Steel |  ACSR |
|-------|--|--|---|---|---|--|
| 60135 | Ø30mm | Ø30mm | Ø12mm | Ø12mm | Ø8mm | Ø30mm |
| 60136 | Ø33mm | Ø33mm | Ø12mm | Ø12mm | Ø8mm | - |
| 60137 | Ø35mm | Ø35mm | - | - | - | - |
| 60138 | Ø53mm | Ø53mm | - | - | - | Ø53mm |
| 60145 | Ø55mm | Ø55mm | - | - | - | - |
| 60146 | Ø80mm | Ø80mm | - | - | - | - |
| 60147 | Ø100mm | Ø100mm | - | - | - | - |

Estos valores pueden variar en función de distintas resistencias, diámetros y calidades
 This info can be modified according to different resistance values, diameters and quality
 Ces valeurs peuvent varier suivant les différentes résistances, diamètres et qualités



Taladro no incluido / Drill not included / Perceuse exclude

EGA Master S.A.
 ART IN INNOVATION





TENAZA RUSA MASTERPLUS MASTERPLUS TOWER PINCER TENAILLE RUSSE MASTERPLUS



Premio a la Innovación, Certamen Metalmaq, Lisboa 2001
Innovation Award, Metalmaq, Lisbon 2001
Prix a L'Innovation, Metalmaq, Lisbonne 2001

Medalla de Bronce, Salon Internacional de la Invención, París 2004
Bronze Medal, International Inventors Competition, Paris 2004
Medaille de Bronze, Salon International de L'Invention, Paris 2004

EGA Master es pionera mundial en desarrollar una tenaza rusa para encofradores de una capacidad de corte muy superior (clavos de 4,5mm) debido a su innovador concepto.

EGA Master is worldwide pioneer on the development of a tower pincer with a much higher cutting capacity due to its innovative design (cuts up to 4,5mm diameter nails).

EGA Master S.A. est le premier au monde, grâce à un concept innovateur, à développer une Tenaille Russe pour les coffreurs, avec une capacité de coupe très élevée (clous de 4,5mm).

1 Diseño especial de las zonas de corte y sistema de eje desplazado, mejorando notablemente su capacidad y permitiendo cortar clavos de hasta 4,5mm de diámetro.

Special cutting edge design in addition to displaced joint axle improve notably cutting capacity, allowing it to cut nails up to 4,5mm in diameter.

Dessin spécial des zones de coupe et du système d'axe déporté, améliorant notablement sa capacité et permettant de couper des clous allant jusqu'à 4,5 mm de diamètre.

2 Sistema de remache dentado de gran duración sin holgura.

Long lasting teeth riveted pin system for smooth action.

Système de rivetage denté qui garantit une plus grande durée de vie.

3 TITACROM® -tratamiento superficial especial, resistente a la corrosión y a los golpes, antireflectante y de gran atractivo con mangos confortables y antideslizantes.

TITACROM®- special surface treatment, rust-proof does not chip off. It is non-reflecting and with very attractive finishing.

TITACROM® – traitement superficiel spécial, résistant à la corrosion et aux coups, anti-réfléchissant et de grand attrait avec un manche confortable et anti-dérapant.

4 Mangos por inmersión antideslizantes.

Anti-slippery dipping handles.

Manches avec anti-dérapant par immersion.

5 Patentado.

Patented.

Brevetée.

capacidad de corte
cutting capacity
capacité de coupe

60% +



4 TENAZAS / PINCERS / ZANGE / TENAILLES / TENAGLIE / NIPTANG / ALICATES



TENAZA RUSA / TOWER PINCER / TENAILLE RUSSE / RABITZZANGE / TENAGLIE PER CEMENTISTI
VLECHTWERKTANG / TURQUES RUSSA **Metalmag**

MASTERPLUS

TITACROM®



DIN 9242

| COD | ← L → | ← A → | ← B → | ← C → | | | |
|-------|-------|-------|-------|-------|-----|----|---|
| 62123 | 9" | 35 | 12 | 23 | 400 | 10 | 1 |
| 62124 | 10" | 35 | 12 | 23 | 415 | | |
| 62125 | 11" | 37 | 16 | 26 | 470 | | |

MASTERPLUS AUTO OPENING

TITACROM®

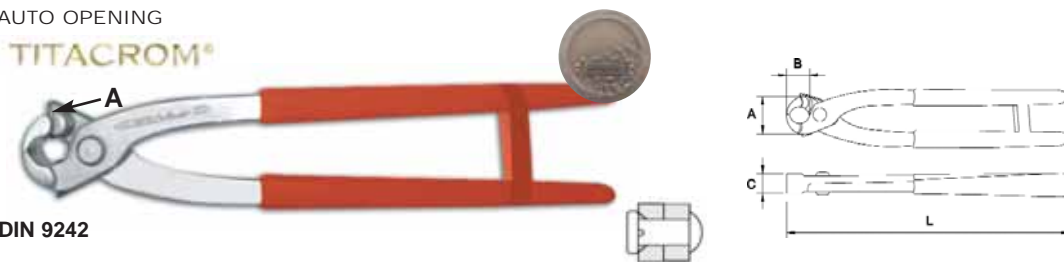

DIN 9242

| COD | ← L → | ← A → | ← B → | ← C → | | | |
|-------|-------|-------|-------|-------|-----|----|---|
| 62281 | 9" | 35 | 12 | 23 | 400 | 10 | 1 |
| 62282 | 10" | 35 | 12 | 23 | 415 | | |

MUELLE / SPRING / RESORT / MOLLA / FEDER / MOLA



| COD | ← L → |
|-------|---------|
| 64269 | 9", 10" |

MASTERPLUS

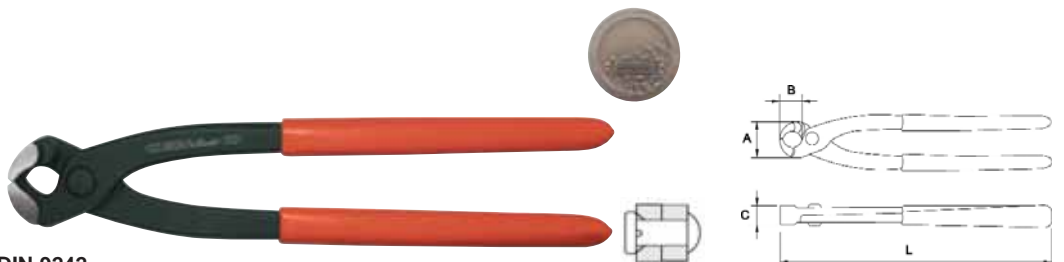

DIN 9242

| COD | ← L → | ← A → | ← B → | ← C → | | | |
|-------|-------|-------|-------|-------|-----|----|---|
| 62140 | 9" | 35 | 12 | 23 | 400 | 10 | 1 |
| 62142 | 10" | 35 | 12 | 23 | 415 | | |
| 62138 | 11" | 37 | 16 | 26 | 470 | | |

MASTERPLUS

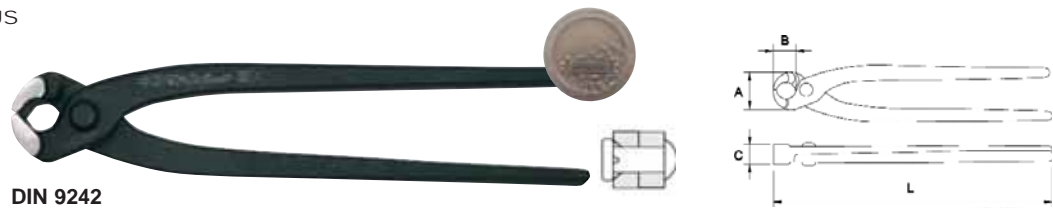

DIN 9242

| COD | L | A | B | C | | | |
|-------|-----|----|----|----|-----|----|---|
| 62141 | 9" | 35 | 12 | 23 | 400 | | |
| 62143 | 10" | 35 | 12 | 23 | 415 | 10 | 1 |
| 62139 | 11" | 37 | 16 | 26 | 470 | | |

TENAZA PARA ENGASTAR / CRIMPING TOWER Pincer / PINCE A SERTIR / KABELKLEMMZANGE
KABELKLEMTANG / TENAGLIA / TURQUÊS PARA ENGASTAR



| COD | L | A | B | C | D | | | |
|-------|----|----|----|----|----|-----|----|---|
| 62210 | 9" | 35 | 12 | 23 | 11 | 325 | 10 | 1 |

TENAZA DE CARPINTERO / CARPENTER Pincer / TENAILLE DE MANUISIER / KANTENZANGE /
TENAGLIE PER CARPENTIERI KLEMTANG / TURQUES DE CARPINTEIRO

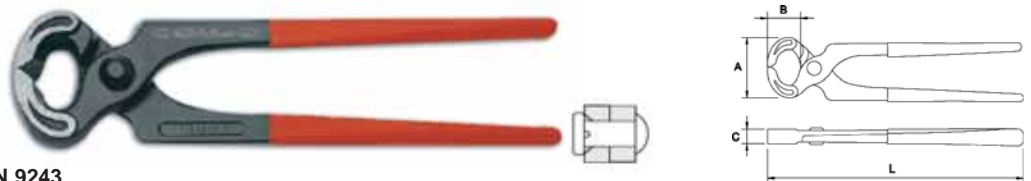

DIN 9243

| COD | L | A | B | C | | | |
|-------|----|----|----|----|-----|---|---|
| 62437 | 6" | 47 | 20 | 19 | 250 | | |
| 62438 | 7" | 52 | 24 | 20 | 310 | | |
| 62439 | 8" | 54 | 26 | 21 | 380 | 6 | 1 |
| 62440 | 9" | 56 | 27 | 25 | 400 | | |



DIN 9243

| COD | L | A | B | C | | | |
|-------|----|----|----|----|-----|---|---|
| 62144 | 6" | 47 | 20 | 19 | 250 | | |
| 62145 | 7" | 52 | 24 | 20 | 310 | | |
| 62146 | 8" | 54 | 26 | 21 | 360 | 6 | 1 |
| 62436 | 9" | 56 | 27 | 25 | 400 | | |

4 TENAZAS / PINCERS / ZANGE / TENAILLES / TENAGLIE / NIPTANG / ALICATES



TENAZA DE CANAL / BOX JOINT / MULTIPRISE ENTREPASSEE / WASSERPUMPENZANGE / PINZE REGOLABILI / WATERPOMPTANG / BICO DE PAPAGAIO

AUTO GRIP

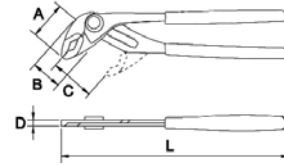
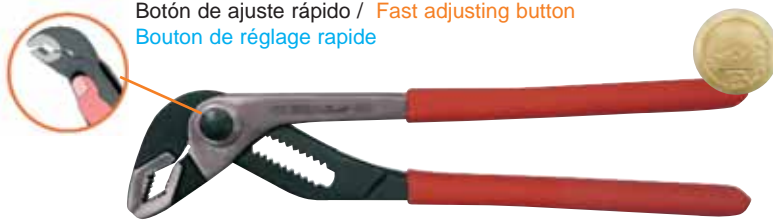

DIN 8976

| COD | L | A | B | C | D | | | |
|-------|------|------|------|------|------|-----|---|---|
| 62328 | 8" | 28mm | 30mm | 37mm | 9mm | 300 | 6 | 1 |
| 62329 | 9,5" | 38mm | 35mm | 43mm | 11mm | 400 | | |

TITACROM® Bimat

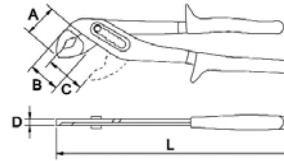

DIN 8976

| COD | L | A | B | C | D | | | |
|-------|-----|------|------|------|-----|-----|---|---|
| 62297 | 10" | 32mm | 36mm | 34mm | 7mm | 400 | 6 | 1 |
| 62298 | 12" | 43mm | 46mm | 46mm | 8mm | 615 | | |

TITACROM®

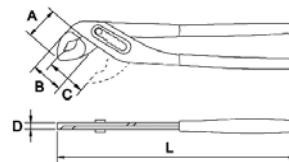

DIN 8976

| COD | L | A | B | C | D | | | |
|-------|-----|------|------|------|-----|-----|---|---|
| 62294 | 10" | 32mm | 36mm | 34mm | 7mm | 400 | 6 | 1 |
| 62295 | 12" | 43mm | 46mm | 46mm | 8mm | 615 | | |

TITACROM®

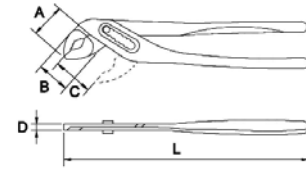

DIN 8976

| COD | L | A | B | C | D | | | |
|-------|-----|------|------|------|-----|-----|---|---|
| 62291 | 10" | 32mm | 36mm | 34mm | 7mm | 400 | 6 | 1 |
| 62292 | 12" | 43mm | 46mm | 46mm | 8mm | 615 | | |

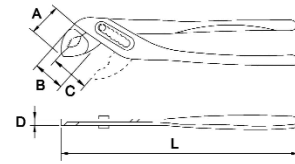

DIN 8976

| COD | L | A | B | C | D | | | |
|-------|-----|------|------|------|-----|-----|---|---|
| 62133 | 7" | 28mm | 28mm | 25mm | 7mm | 165 | 6 | 1 |
| 62135 | 10" | 32mm | 36mm | 34mm | 7mm | 400 | | |
| 62134 | 12" | 43mm | 46mm | 46mm | 8mm | 615 | | |

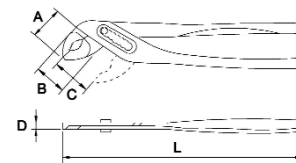

DIN 8976

| COD | L | A | B | C | D | | | |
|-------|-----|------|------|------|-----|-----|---|---|
| 62127 | 7" | 28mm | 28mm | 25mm | 7mm | 165 | 6 | 1 |
| 62128 | 10" | 32mm | 36mm | 34mm | 7mm | 350 | | |
| 62129 | 12" | 43mm | 46mm | 46mm | 8mm | 510 | | |

4 TENAZAS / PINCERS / ZANGE / TENAILLES / TENAGLIE / NIPTANG / ALICATES



TENAZA DE CANAL TIPO ALEMAN / GERMAN TYPE BOX JOINT PLIERS / PINCE A CREMAILLIERE TYPE ALLEMAND / WASSER-PUMPEZANGE DEUTSCHER MODELL / PINZA POLIGRIP MOD. TEDESCO / WATERPOMPTANG DUIJS MODEL / ALICATE BICO PAPAGAIO TIPO ALEMÃO



DIN 8976

NEW

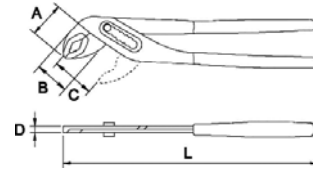

| COD | L | A | B | C | D | | | |
|-------|-----|------|------|------|------|-----|---|---|
| 62793 | 7" | 25mm | 26mm | 28mm | 6mm | 150 | | |
| 62794 | 10" | 34mm | 34mm | 31mm | 7mm | 340 | 6 | 1 |
| 62795 | 12" | 40mm | 41mm | 41mm | 9mm | 500 | | |
| 62796 | 16" | 60mm | 57mm | 69mm | 11mm | 665 | | |

PICO DE LORO / GROOVE JOINT / MULTIPRISE A CREMAILLIERE / WASSERPUMPENZANGE / PINZE REGOLABILI / WATERPOMPTANG MET RILLENVERSTELLING / BICO DE PAPAGAIO

AUTO GRIP

Botón de ajuste rápido / Fast adjusting button
Bouton de réglage rapide



DIN 8976

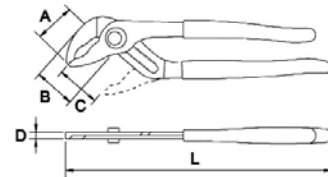

| COD | L | A | B | C | D | | | |
|-------|-----|------|------|------|------|-----|---|---|
| 62411 | 8" | 30mm | 37mm | 31mm | 10mm | 300 | | |
| 62412 | 10" | 37mm | 41mm | 47mm | 12mm | 450 | 6 | 1 |
| 62413 | 12" | 48mm | 48mm | 49mm | 13mm | 650 | | |

TITACROM® **BMAT**



DIN 8976

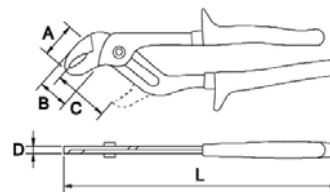

| COD | L | A | B | C | D | | | |
|-------|-----|------|------|------|------|-----|---|---|
| 62445 | 8" | 30mm | 36mm | 30mm | 9mm | 300 | | |
| 62446 | 10" | 34mm | 40mm | 36mm | 10mm | 465 | 6 | 1 |
| 62447 | 12" | 43mm | 48mm | 48mm | 11mm | 705 | | |

TITACROM®



DIN 8976

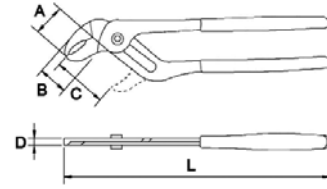

| COD | L | A | B | C | D | Weight | Box | Case |
|-------|-----|------|------|------|------|--------|-----|------|
| 62105 | 8" | 30mm | 36mm | 30mm | 9mm | 240 | | |
| 62106 | 10" | 34mm | 40mm | 36mm | 10mm | 390 | 6 | 1 |
| 62107 | 12" | 43mm | 48mm | 48mm | 11mm | 620 | | |
| 62108 | 16" | 67mm | 57mm | 84mm | 12mm | 1290 | | |

ALICATE TIPO FORD / SLIP JOINT PLIER / PINCE BIPRISE / MECHANIKERZANGE
PINZE PER GASISTI / TANG DUBBELE INSTELLING / ALICATE MOTORISTA

| COD | L | Weight | Box | Case |
|-------|-----|--------|-----|------|
| 62090 | 6" | 200 | 6 | 1 |
| 62091 | 8" | 275 | | |
| 62092 | 10" | 430 | | |

TITACROM®



ALICATE MULTIUSOS / FENCING PLIER / PINCE POUR BARRIERE / HEKWERTANG
ZAUNZANGE

| COD | L | Weight | Box | Case |
|-------|-----|--------|-----|------|
| 62211 | 10" | 635 | 6 | 1 |

TITACROM®



La más galardonada
The most awarded
La plus primée

4 TENAZAS / PINCERS / ZANGE / TENAILLES / TENAGLIE / NIPTANG / ALICATES



EXPOSITORES / DISPLAYS / PRESENTOIRS / STÄNDER / ESPOSITORE / DISPLAY STAND

DE CANAL / WASSERPUMPENZANGE / MULTIPRISE ENTREPASSEE / BOX JOINT / PINZE REGOLABILI / WATERPOMPTANG
BICO DE PAPAGAIO

| UN. | COD:69416 | | |
|-----|-----------|-----|--|
| 6 | 62133 | 7" | |
| 6 | 62135 | 10" | |
| 6 | 62134 | 12" | |
| 6 | 62127 | 7" | |
| 6 | 62128 | 10" | |
| 6 | 62129 | 12" | |

| UN. | COD:69417 | | |
|-----|-----------|-----|--|
| 6 | 62291 | 10" | |
| 6 | 62292 | 12" | |
| 6 | 62294 | 10" | |
| 6 | 62295 | 12" | |
| 6 | 62297 | 10" | |
| 6 | 62298 | 12" | |

| UN. | COD:69420 | | |
|-----|-----------|-----|--|
| 18 | 62291 | 10" | |
| 18 | 62292 | 12" | |

| UN. | COD:69421 | | |
|-----|-----------|-----|--|
| 18 | 62294 | 10" | |
| 18 | 62295 | 12" | |

| UN. | COD:69418 | | |
|-----|-----------|-----|--|
| 12 | 62133 | 7" | |
| 12 | 62135 | 10" | |
| 12 | 62134 | 12" | |

| UN. | COD:69419 | | |
|-----|-----------|-----|--|
| 12 | 62127 | 7" | |
| 12 | 62128 | 10" | |
| 12 | 62129 | 12" | |

| UN. | COD:69422 | | |
|-----|-----------|-----|--|
| 12 | 62105 | 8" | |
| 12 | 62106 | 10" | |
| 12 | 62108 | 12" | |

| UN. | COD:69423 | | |
|-----|-----------|-----|--|
| 12 | 62445 | 8" | |
| 12 | 62446 | 10" | |
| 12 | 62447 | 12" | |



TENAZA RUSA+TENAZA DE CARPINTERO / TOWER PINCER+CARPENTER PINCER / TENAILLES RUSSE+TENAILLES DE MENUISIER
RABITZZANGE+KANTENZANGE / TENAGLIE PER CEMENTISTI+TENAGLIE PER CARPENTIERI / VLECHTWERKTANG+KLEMTANG
TURQUES RUSSA+TURQUES DE CARPINTEIRO

| UN. | COD:69427 | | |
|-----|-----------|-----|--|
| 6 | 62141 | 9" | |
| 6 | 62143 | 10" | |
| 6 | 62140 | 9" | |
| 6 | 62142 | 10" | |
| 6 | 62123 | 9" | |
| 6 | 62124 | 10" | |

| UN. | COD:69430 | | |
|-----|-----------|-----|--|
| 6 | 62123 | 9" | |
| 6 | 62124 | 10" | |
| 6 | 62140 | 9" | |
| 6 | 62142 | 10" | |
| 6 | 62438 | 7" | |
| 6 | 62439 | 8" | |

| UN. | COD:69428 | | |
|-----|-----------|----|--|
| 6 | 62144 | 6" | |
| 12 | 62145 | 7" | |
| 12 | 62146 | 8" | |
| 6 | 62436 | 9" | |

| UN. | COD:69429 | | |
|-----|-----------|----|--|
| 6 | 62437 | 6" | |
| 12 | 62438 | 7" | |
| 12 | 62439 | 8" | |
| 6 | 62440 | 9" | |

| UN. | COD:69424 | | |
|-----|-----------|-----|--|
| 12 | 62141 | 9" | |
| 12 | 62143 | 10" | |
| 12 | 62139 | 11" | |

| UN. | COD:69425 | | |
|-----|-----------|-----|--|
| 12 | 62140 | 9" | |
| 12 | 62142 | 10" | |
| 12 | 62138 | 11" | |

| UN. | COD:69426 | | |
|-----|-----------|-----|--|
| 12 | 62123 | 9" | |
| 12 | 62124 | 10" | |
| 12 | 62125 | 11" | |



GRIP TITACROM®

TENAZA GRIP CON CORTACABLES / GRIP PLIER WITH WIRE CUTTER / PINCE ETAU A COUPE / CABLE GRIPZANGE F/ DRAHTSCHNEIDER / PINZA A MORSETTO CON TAGLIACAVI / DRAADKNIP GRIPTANG / ALICATE DE GRIF CORTA CABOS



| COD | L | A | B | BOCA / JAW | | | |
|-------|-----|------|------|--|-----|---|---|
| 62179 | 4" | 7mm | 11mm | CURVA / CURVED COURBÉE / PIEGATA GEBOGEN | 100 | 6 | 1 |
| 62177 | 5" | 8mm | 13mm | | 160 | | |
| 62178 | 7" | 13mm | 21mm | | 365 | | |
| 62172 | 10" | 14mm | 24mm | | 535 | | |

TENAZA GRIP BOCA CURVA SIN CORTACABLES / CURVED JAW GRIP PLIER WITHOUT WIRE CUTTER / PINCE ETAU SANS COUPE CABLE / GRIPZANGE MIT GEBOGEN BACKEN OHNE DRAHTSCHNEIDER / PINZA GRIP BOCCA CURVA SENZA TAGLIACAVI / GEBOGEN GRIPTANG ZONDER DRAADSNIJDER / ALICATE DE GRIF BOCA CURVA SEM CORTA CABOS



| COD | L | A | B | BOCA / JAW | | | |
|-------|----|------|------|--|-----|---|---|
| 62260 | 7" | 9mm | 21mm | CURVA / CURVED COURBÉE / PIEGATA GEBOGEN | 350 | 6 | 1 |
| 62261 | 9" | 11mm | 24mm | | 500 | | |

TENAZA GRIP BOCA RECTA / STRAIGHT JAW GRIP PLIER / PINCE ÉAU BECS DROITS / GRIPZANGE MIT GERADE BACKEN / PINZE A MORSETTO DIRITTE / GRIPTANG MET RECHTE BEKKEN / ALICATES DE GRIF BOCA RECTA

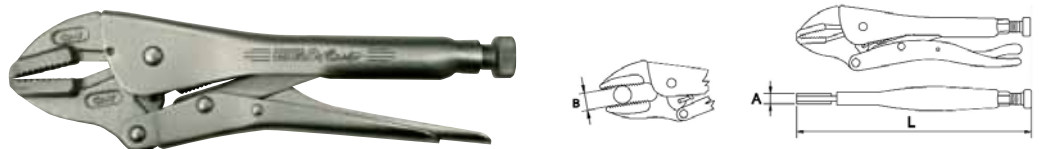

| COD | L | A | B | BOCA / JAW | | | |
|-------|-----|------|------|---|-----|---|---|
| 62231 | 10" | 16mm | 24mm | RECTA / STRAIGHT DROITE / GEBOGEN DIREITA | 520 | 6 | 1 |

BOCAS LARGAS / LONG NOSE JAWS / BECS LONGS / GRIPZANGE MIT LANGEN BACKEN / GRIPTANG MET LANGE BEKKEN / PINZE A MORSETTO PIATTO / PONTAS COMPRIDAS



| COD | L | A | B | | | |
|-------|------|------|------|-----|---|---|
| 62485 | 6,5" | 8mm | 19mm | 185 | 6 | 1 |
| 62486 | 8,5" | 10mm | 34mm | 360 | | |

4 TENAZAS / PINCERS / ZANGE / TENAILLES / TENAGLIE / NIPTANG / ALICATES



CON MORDAZAS PARA CHAPA / SHEET METAL GRIP PLIER / POUR TOLE / GRIPZANGE FÜR STAHLPLATTEN
 GRIPTANG VOOR STAALPLAAT / PER LAMIERE / COM MORDENTES PARA CHAPA



| COD | L | A | B | C | Weight | Material | Accessories |
|-------|----|------|------|------|--------|----------|-------------|
| 62487 | 8" | 78mm | 42mm | 17mm | 490 | 6 | 1 |

CON MORDAZAS PARA SOLDADURA / WELDING GRIP PLIER / POUR CORNIERE / SCHWEISSERGRIPZANGE
 GRIPTANG VOOR LASSEN / PER SOLDATURA / COM MORDENTES PARA SOLDADURA



| COD | L | A | B | Weight | Material | Accessories |
|-------|-----|------|------|--------|----------|-------------|
| 62508 | 9" | 68mm | 26mm | 575 | 6 | 1 |
| 62509 | 11" | 75mm | 35mm | 800 | | |

CON MORDAZAS EN "C" / "C" CLAMPS GRIP PLIER / PINCE-ETAU COL DE CYGNE / GRIPZANGE MIT "C" BACKEN
 GRIPTANG MET "C" BEKKEN / PINZE A MORSETTO A FORMA DI "C" / COM MORDENTES EM "C"

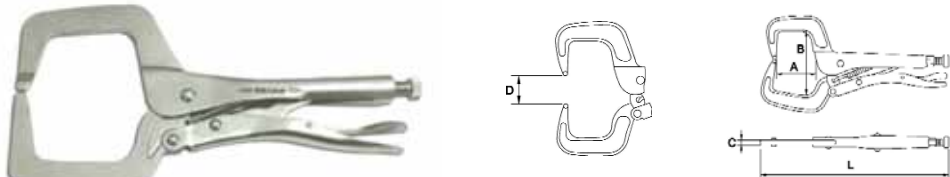

| COD | L | A | B | C | D | Weight | Material | Accessories |
|-------|-----|------|------|-----|------|--------|----------|-------------|
| 62492 | 11" | 76mm | 97mm | 7mm | 50mm | 760 | 6 | 1 |

CON MORDAZAS EN "C" BASCULANTES / "C" CLAMPS SWIVEL PADS GRIP PLIER / PINCE-ETAU A MACHOIRES BASCULANTES
 GRIPZANGE MIT SCHWENKBACKEN / GRIPTANG MET KANTELENDE BEKKEN / PINZE A MORSETTO BASCULANTE
 COM MORDENTES EM BASCULANTES



| COD | L | A | B | C | D | Weight | Material | Accessories |
|-------|-----|-------|-------|------|-------|--------|----------|-------------|
| 62489 | 7" | 55mm | 55mm | 5mm | 15mm | 270 | 6 | 1 |
| 62490 | 11" | 68mm | 93mm | 6mm | 45mm | 795 | | |
| 62491 | 18" | 250mm | 100mm | 12mm | 118mm | 1440 | | |

TENAZAS / PINCERS / ZANGE / TENAILLES / TENAGLIE / NIPTANG / ALICATES

TENAZA GRIP CON CADENA / GRIP PLIER WITH CHAIN / PINCE ÉTAU À CHAÎNE / GRIPZANGE MIT KETTE / PINZE A MORSETTO CON CATENA / KETTINGGRIPTANG / ALICATES DE GRIF COM CORRENTE

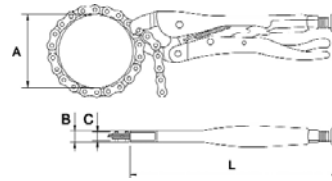

| | | | | | | | | |
|------------|-------|-------|-------|-------|-----|-----|---|---|
| COD | ← L → | ← A → | ← B → | ← C → | | | | |
| 62174 | 9" | 150mm | 13mm | 7mm | 20" | 800 | 6 | 1 |

GRIP-SARGENTO / CLAMP GRIP PLIER / PINCE-ETAU SERRE-JOINT / GRIPZANGE MIT KLEMME / GRIPTANG MET KLEBEKKEN / PINCE GRIP A MORSETTO / ALICATE PRESSÃO COM GRAMPO

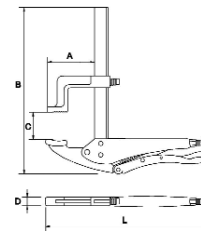

| | | | | | | | | | |
|------------|-------|-------|-------|-------|-------|-------|------|---|---|
| COD | ← L → | ← A → | ← B → | ← C → | ← D → | | | | |
| 62571 | 10" | 79mm | 292mm | 170mm | 15mm | 116mm | 1180 | 1 | 1 |

EGA *Master* S.A.
ART IN INNOVATION



5

EXTRACTORES / GEAR PULLERS / EXTRACTEURS / ABZIEHERS / TREKKERS ESTRATTORI / EXTRACTORES

EXTRACTOR 3 GARRAS ARTICULADAS 2 POSICIONES / 3 JAW GEAR PULLER 2 POSITION / EXTRACTEUR 3 BRAS ARTICULES 2 POSITIONS / AUSSEN-INNENABZIEHER 3 KLAUEN / BINNEN EN BUITENTREKKER 3 BEKKEN / ESTRATTORE A 3 BRACCIA 2 POSIZIONI / EXTRACTOR DE 3 GARRAS ARTICULADAS 2 POSIÇÕES

| COD | Ø | A | B | C | Kg | |
|-------|-----|----|--------|-----|------|---|
| 62576 | 4" | 14 | 20-120 | 110 | 0,70 | 1 |
| 62577 | 6" | 17 | 20-165 | 150 | 1,10 | |
| 62578 | 9" | 19 | 36-230 | 210 | 2,70 | |
| 62579 | 12" | 24 | 50-320 | 250 | 5,75 | |
| 62580 | 16" | | 80-420 | 350 | 8 | |

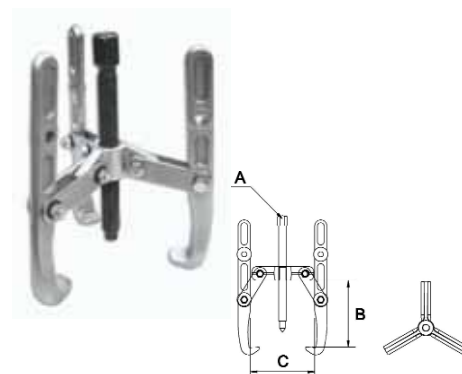

EXTRACTOR 3 GARRAS ARTICULADAS REVERSIBLES / 3 JAW REVERSIBLE GEAR PULLER / EXTRACTEUR 3 BRAS ARTICULES REVERSIBLES / AUSSENABZIEHER 3 KLAUEN / BUITENTREKKER 3 BEKKEN / ESTRATTORE A 3 BRACCI REVERSIBILI / EXTRACTOR DE 3 GARRAS ARTICULADO REVERSIVEL

| COD | Ø | A | B | C | Kg | |
|-------|-----|----|--------|-----|------|---|
| 62572 | 3" | 19 | 15-80 | 70 | 0,40 | 1 |
| 62573 | 6" | 21 | 25-160 | 120 | 1,75 | |
| 62574 | 8" | 24 | 30-210 | 155 | 3,16 | |
| 62575 | 12" | 29 | 50-317 | 235 | 9 | |

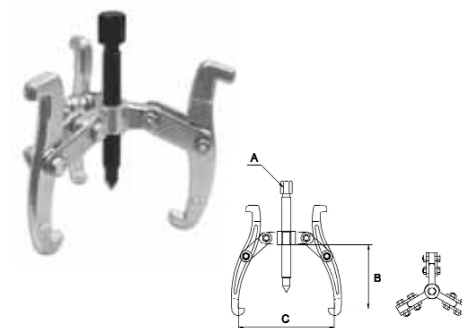

EXTRACTOR 2 GARRAS ARTICULADAS 2 POSICIONES / 2 JAW GEAR PULLER 2 POSITION / EXTRACTEUR 2 BRAS ARTICULES 2 POSITIONS / AUSSEN-INNENABZIEHER 2 KLAUEN / BINNEN EN BUITENTREKKER 2 BEKKEN / ESTRATTORE A 2 BRACCIA 2 POSIZIONI / EXTRACTOR DE 2 GARRAS ARTICULADAS 2 POSIÇÕES

| COD | Ø | A | B | C | Kg | |
|-------|-----|----|--------|-----|------|---|
| 62581 | 4" | 14 | 20-120 | 110 | 0,50 | 1 |
| 62582 | 6" | 15 | 20-165 | 150 | 0,80 | |
| 62583 | 9" | 17 | 36-230 | 210 | 2 | |
| 62584 | 12" | | 50-320 | 250 | 4 | |
| 62585 | 16" | 26 | 80-420 | 350 | 5,80 | |

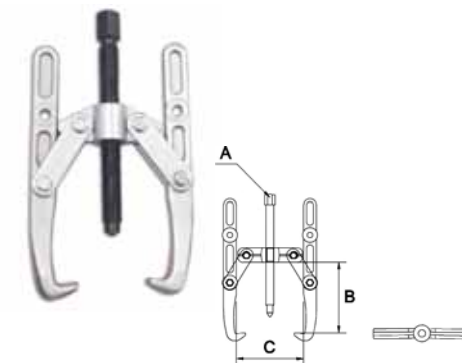

EXTRACTOR 2 GARRAS UNIVERSAL / UNIVERSAL 2 JAW GEAR PULLER / EXTRACTEUR DEUX BRAS UNIVERSEL / UNIVERSELLE AUSZIEHER 2 KLAUEN / ESTRATTORE UNIVERSALE A 2 BRACCIA / UNIVERSELE 2-ARMIGE POLIETREKKER / EXTRACTOR DE DUAS GARRAS UNIVERSAL

| COD | Nº | A | B | C | Kg | |
|-------|----|----|--------|-----|------|---|
| 62586 | 1 | 17 | 25-80 | 100 | 1 | 1 |
| 62587 | 2 | 17 | 25-130 | | 1,20 | |
| 62588 | 3 | 23 | 50-160 | 150 | 2,70 | |
| 62589 | 4 | 25 | 60-200 | | 3,10 | |
| 62590 | 5 | 27 | 80-250 | 200 | 6,50 | |

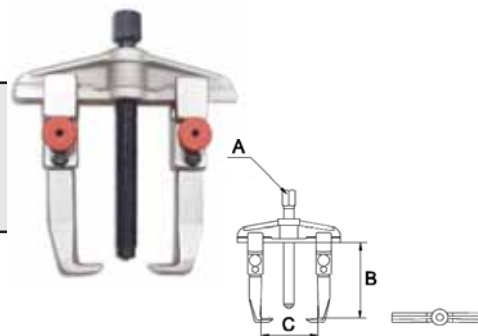

EXTRACTOR 3 GARRAS UNIVERSAL / UNIVERSAL 3 JAW GEAR PULLER / EXTRACTEUR TROIS BRAS UNIVERSEL / UNIVERSELLE AUSZIEHER 3 KLAUEN / ESTRATTORE UNIVERSALE A 3 BRACCIA / UNIVERSELE 3-ARMIGE POLIETREKKER / EXTRACTOR DE 3 GARRAS UNIVERSAL

| COD | ∅ | A | B | C | Kg | |
|-------|----|----|--------|-----|-----|---|
| 62828 | 5" | 17 | 25-130 | 100 | 1,5 | 1 |
| 62829 | 8" | 22 | 60-200 | 150 | 4 | |

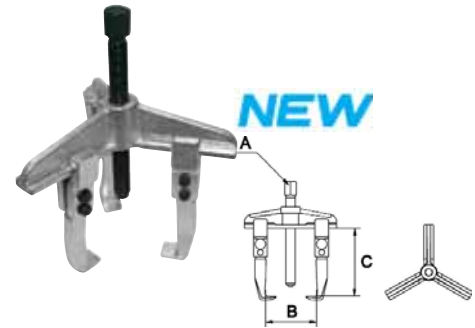

EXTRACTOR 3 GARRAS / 3 JAW GEAR PULLER / EXTRACTEUR 3 BRAS / AUSZIEHER 3 KLAUEN / ESTRATTORE A 3 BRACCIA 3-ARMIGE POLIETREKKER / EXTRACTOR DE 3 GARRAS

| COD | ∅ | A | B | C | Kg | |
|-------|----|----|--------|-----|-----|---|
| 62816 | 4" | 14 | 20-110 | 110 | 1,3 | 1 |
| 62817 | 6" | 19 | 25-160 | 140 | 2,6 | |



EXTRACTOR 2 GARRAS / 2 JAW GEAR PULLER / EXTRACTEUR DEUX BRAS / AUSZIEHER 2 KLAUEN / ESTRATTORE A 2 BRACCIA 2-ARMIGE POLIETREKKER / EXTRACTOR DE DUAS GARRAS

| COD | ∅ | A | B | C | Kg | |
|-------|----|----|--------|-----|----|---|
| 62818 | 4" | 14 | 20-110 | 110 | 1 | 1 |
| 62819 | 6" | 19 | 25-160 | 140 | 2 | |

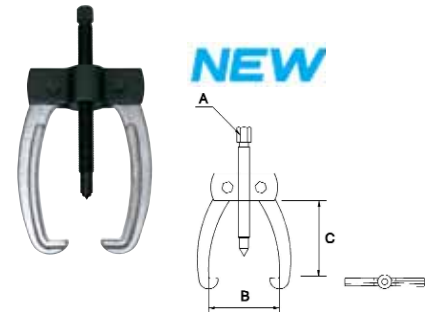

EXTRACTOR 3 GARRAS LIGERO / 3 JAW LIGH GEAR PULLER / EXTRACTEURS 3 BRAS LÉGER / AUSZIEHER 3 KLAUEN ESTRATTORE A 3 BRACCIA LEGA LEGGERA / 3-ARMIGE POLIETREKKER / EXTRACTOR DE TRÊS GARRAS LIGEIRO

| COD | ∅ | A | B | C | Kg | |
|-------|--------|----|-------|----|------|---|
| 62821 | 2" | 12 | 15-60 | 50 | 0,25 | 1 |
| 62822 | 2.3/4" | | 15-70 | 70 | 0,3 | |
| 62823 | 3.1/4" | | 15-80 | 80 | 0,35 | |

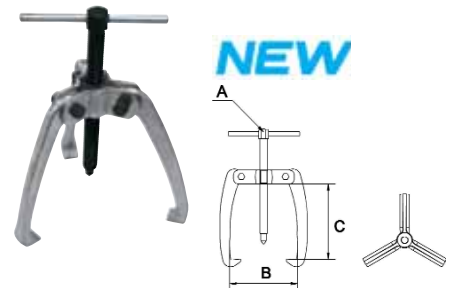

EXTRACTOR 2 GARRAS LIGERO / 2 JAW LIGH GEAR PULLER / EXTRACTEURS 2 BRAS LÉGER / AUSZIEHER 2 KLAUEN ESTRATTORE A 2 BRACCIA LEGA LEGGERA / 2-ARMIGE POLIETREKKER / EXTRACTOR DE DUAS GARRAS LIGEIRO

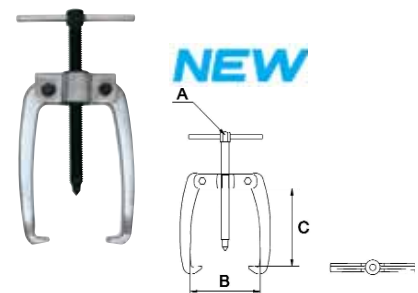

| COD | ∅ | A | B | C | Kg | |
|-------|--------|----|-------|----|------|---|
| 62824 | 2" | 12 | 15-60 | 50 | 0,25 | 1 |
| 62825 | 2.3/4" | | 15-70 | 70 | 0,3 | |
| 62826 | 3.1/4" | | 15-80 | 80 | 0,35 | |





5

EXTRACTORES / GEAR PULLERS / EXTRACTEURS / ABZIEHERS / TREKKERS ESTRATTORI / EXTRACTORES

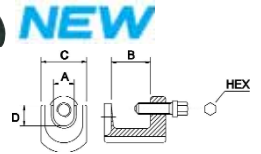

EXTRACTOR DE ROTULAS / BALL JOINT PULLER / EXTRACTEUR DE ROUEMENTS / KUGELGELENKABZIEHER / ESTRATTORE A SFERE / KOGELGEWICHTTREKKER / EXTRACTOR DE RÓTULAS

| COD | A | B | C | D |  |  |
|-------|----|----|----|----|---|--|
| 62831 | 19 | 55 | 44 | 21 | 1,8 | 0,8 |



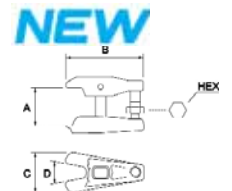

| COD | A | B | C | D |  |  |
|-------|----|-----|----|-------|---|--|
| 62832 | 50 | 100 | 56 | 18-22 | 19 | 0,7 |

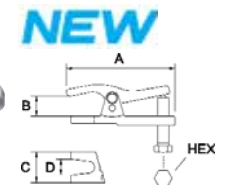

| COD | A | B | C | D |  |  |
|-------|-----|-------|----|----|---|--|
| 62833 | 160 | 12-50 | 47 | 20 | 24 | 1,2 |
| 62834 | | 60-80 | | 17 | 1,5 | |



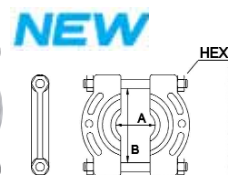

GUILLOTINA PARA RODAMIENTOS Y POLEAS / BEARING SEPARATOR / GUILLOTINE POUR ROUEMENTS ET POULIES / LAGER-SEPARATOR / SEPARATORE DI CUSCINETTI E PULEGGE / ROLLAGER SEPARATOR / GUILHOTINA PARA ROLAMENTOS E POLIS

| COD | Ø | A | B |  |  |
|-------|----|--------|-----|---|--|
| 62836 | 2" | 30-50 | 61 | 17 | 0,5 |
| 62837 | 3" | 50-75 | 92 | 19 | 0,8 |
| 62838 | 4" | 75-105 | 111 | 24 | 1,7 |





EXTRACTORES PARA GUILLOTINAS / PULLERS FOR BEARING SEPARATOR / EXTRACTEURS POUR GUILLOTINES / AUSZIEHER F/LAGERSEPARATOR / ESTRATTORI PER SEPARATORE / TREKKER VOOR ROLLAGER SEPARATOR / EXTRACTOR PARA GUILHOTINAS

| COD |  | L |  |  |
|-------|---|-----|---|--|
| 62840 | 62836 | 75 | 14 | 0,7 |
| 62841 | 62837 | 100 | 17 | 1 |
| 62842 | 62838 | 220 | 19 | 3 |



PROLONGACIONES PARA EXTRACTORES PARA GUILLOTINAS / EXTENSIONS FOR BEARING SEPARATOR PULLERS / PROLONGATEURS POUR EXTRACTEURS PAR GUILLOTINE / VERLÄNGERUNGEN FÜR LAGER SEPARATORABZIEHER / PROLUNGA PER ESTRATTORE PER GHIGLIOTTINA / VERLENGSTUKKEN VOOR ROLLAGER SEPARATOR / PROLONGADORES PARA EXTRACTORES PARA GUILHOTINAS

| COD |  | L |  |  |
|-------|---|-----|---|--|
| 62844 | 62836 | 90 | 14 | 0,2 |
| 62845 | 62837 | 115 | 17 | 0,3 |
| 62846 | 62838 | 220 | 19 | 0,5 |

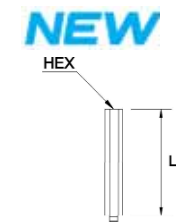

SET

| COD |  |
|-------|---|
| 62883 | 2"-3" 5,75 |



NEW



*LLAVES AJUSTABLES / ADJUSTABLE WRENCHES / CLES A MOLETTE
ROLLGABELSCHLÜSSEL / CHIAVI REGOLABILI A RULLINO
VERSTELBARE SLEUTELS / CHAVES AJUSTAVELS*

LLAVE ALAVESA **BASQUE WRENCH** **CLÉ BASQUE**

Premio a la Innovación, Certamen Metalmaq, Lisboa 2001

Innovation Award, Metalmaq, Lisbon 2001

Prix a L'Innovation, Metalmaq Lisbonne 2001



Medalla de Oro, Salon Internacional de la Invención, París 2004

Gold Medal, International Inventors Competition, Paris 2004

Medaille d'Or, Salon International de L'Invention, Paris 2004

Premio Especial de la Unión Francesa de Inventores, 2003

Special Prize of French Inventors Association, 2003

Prix Spécial de L'Union Française des Inventeurs, 2003

Medalla de Plata del Mundial de la Invención en Innovación, 2003

Silver Medal at the World Innovation and Invention Congress, 2003

Médaille d'Argent au Mondial de L'Invention et d'Innovation, 2003

EGA Master fabrica la más amplia gama de llaves ajustables del mundo, de distintos tamaños, tipos, e innovaciones exclusivas a nivel mundial: ajustables, combi, con acción rápida, con o sin mango Confort, de moleta lateral, aisladas 1000V, a izquierdas, de boca ancha, Titacrom® o fosfatadas.

EGA Master manufactures the widest range of adjustable wrenches in the world, with all kinds of sizes, types, and exclusive innovations: adjustable, combi, quick action, with or without Comfort handle, with lateral nut, 1000V safety insulated, left turn, wide opening, Titacrom® or phosphated.

EGA Master S.A. fabrique la plus grande gamme de clés à molette au monde, avec toutes sortes de dimensions et avec des innovations exclusives au niveau mondial: Ajustables, combi, avec action rapide ou non, avec ou sans manche confort, à molette latérale, isolées 1000 v, tourne à gauche, de grande ouverture, Titacrom ou bruni.

1 Acción rápida para un rápido posicionamiento de la medida.

Quick action system enables fast positioning

Action rapide pour positionner rapidement la mesure désirée.

2 Sistema Combi permite trabajar con elementos poligonales, tubo o tuercas desgastadas.

Combi system for working with polygonal elements, pipes or rounded-off nuts.

Système Combi qui permet de travailler avec des éléments polygonaux, des tubes et des écrous détériorés.

3 Máxima apertura y mínimo espesor de bocas para una máxima operabilidad.

Maximum opening and minimum jaw thickness for best accessibility.

Ouverture maximum et épaisseur minimum des mâchoires pour une action optimale.

4 TITACROM® -tratamiento superficial especial, resistente a la corrosión y a los golpes y roces, es antireflectante y de gran atractivo.

TITACROM®- special surface treatment, rust-proof and anti-chipping off, it is non-reflecting and with very attractive finishing.

TITACROM® – traitement spécial de surface, résistant à la corrosion et aux coups, anti-réfléchissant et de grand attrait avec un manche confortable et anti-dérapant.

5 Mango Confort bi-componente antideslizante para máxima comodidad y de gran atractivo.

Comfort bi-component anti-slippery handle for best comfortability and great attractive design.

Manche confort bi matières anti-dérapant pour une meilleure commodité et une meilleure esthétique.

6 Diseño reforzado para trabajos pesados que multiplica su resistencia al apriete.

Heavy Duty Performance to provide maximum resistance to high torque.

Conception renforcée qui permet une résistance au serrage pour les travaux lourds.

7 Patente mundial.

Worldwide patent.

Brevet mondial.

Las ajustables aisladas a 1000V no se pueden homologar ya que la moleta no puede ser aislada, por lo tanto no se puede garantizar la seguridad del usuario, aunque el material aislante cumple la norma EN-60900 en cuanto a resistencia eléctrica.

The insulated adjustable wrenches 1000V can not be homologated as the wheel nut can not be insulated. The safety of the user can not be guaranteed, even though the insulated material fulfills the requirements of the norm EN-60900 regarding the electrical resistance.

Les clés à molette isolées 1000 V ne peuvent être homologuées, la molette ne pouvant être isolée, nous ne pouvons garantir la sécurité de l'utilisateur, malgré que le matériau isolant est conforme à la norme EN-60900 sur la résistance électrique.

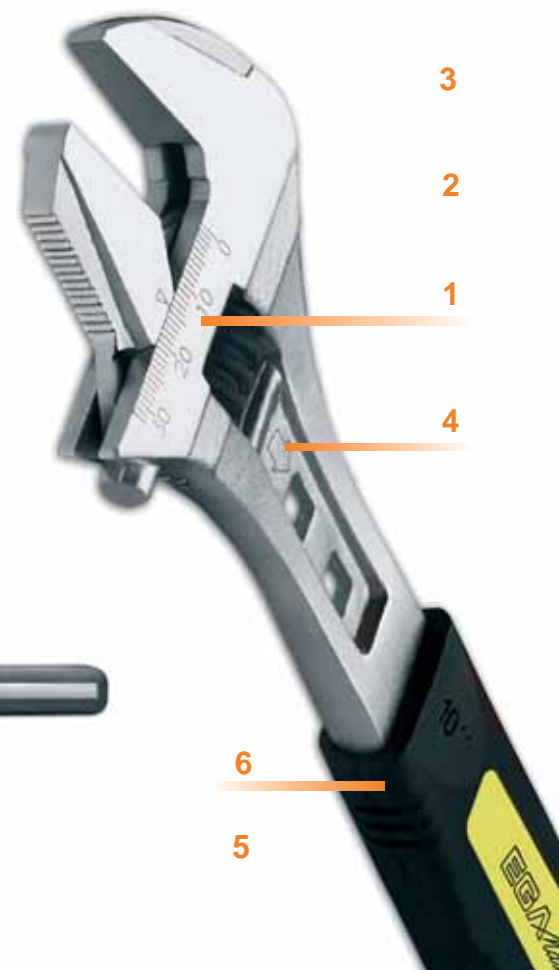

LLAVES AJUSTABLES / ADJUSTABLE WRENCHES / CLES A MOLETTE / ROLLGABELSCHLÜSSEL

TITACROM®

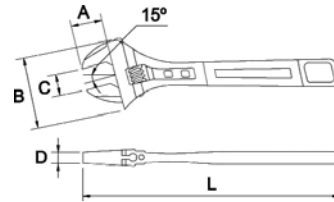

| COD | L | A | B | C | D | gr. | | |
|-------|-----|----|----|------|------|-----|----|---|
| 61109 | 4" | 13 | 34 | 13 | 5,6 | 70 | | |
| 61110 | 6" | 20 | 47 | 19 | 6,5 | 150 | | |
| 61111 | 8" | 25 | 57 | 24 | 7,2 | 285 | 10 | 1 |
| 61112 | 10" | 30 | 70 | 29 | 8,4 | 515 | | |
| 61113 | 12" | 35 | 84 | 33,5 | 10,2 | 850 | 6 | |



| | | | | | | | | |
|-------|-----|------|-----|----|----|------|---|---|
| 61114 | 15" | 44 | 103 | 45 | 13 | 1245 | | |
| 61115 | 18" | 50,5 | 120 | 55 | 14 | 1960 | 1 | 1 |
| 61116 | 24" | 60 | 122 | 62 | 15 | 3100 | | |

TITACROM® COMFORT

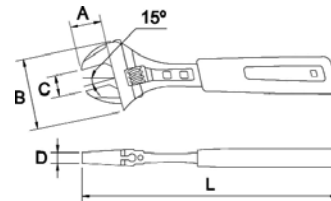

| COD | L | A | B | C | D | gr. | | |
|-------|-----|----|----|------|------|-----|---|---|
| 61906 | 6" | 20 | 47 | 19 | 6,5 | 180 | | |
| 61907 | 8" | 25 | 57 | 24 | 7,2 | 335 | | |
| 61908 | 10" | 30 | 70 | 29 | 8,4 | 595 | 6 | 1 |
| 61909 | 12" | 35 | 84 | 33,5 | 10,2 | 900 | | |



| | | | | | | | | |
|-------|-----|------|-----|----|----|------|---|---|
| 61370 | 15" | 44 | 103 | 45 | 13 | 1250 | | |
| 61371 | 18" | 50,5 | 120 | 55 | 14 | 2050 | 1 | 1 |
| 61372 | 24" | 60 | 122 | 62 | 15 | 3150 | | |

TITACROM® 1000V

1.000V
 IEC 900 resp.
 DIN EN 60 900

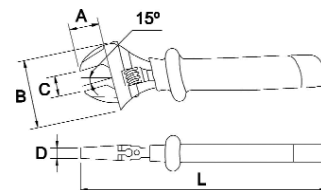

| COD | L | A | B | C | D | gr. | | |
|-------|-----|----|----|------|------|-----|---|---|
| 61984 | 6" | 20 | 47 | 19 | 6,5 | 200 | | |
| 61985 | 8" | 25 | 57 | 24 | 7,2 | 365 | | |
| 61986 | 10" | 30 | 70 | 29 | 8,4 | 615 | 6 | 1 |
| 61987 | 12" | 35 | 84 | 33,5 | 10,2 | 970 | | |

6

LLAVES AJUSTABLES / ADJUSTABLE WRENCHES / CLES A MOLETTE ROLLGABELSCHLÜSSEL / CHIAVI REGOLABILI A RULLINO VERSTELBARE SLEUTELS / CHAVES AJUSTAVELS

LLAVES AJUSTABLES / ADJUSTABLE WRENCHES / CLES A MOLETTE / ROLLGABELSCHLÜSSEL

FOSFATADA / PHOSPHATED / PHOSPHATEE BRUNIE / PHOSPHATIERT / FINITURA BRUNITA / ZWART / BRUNIDA

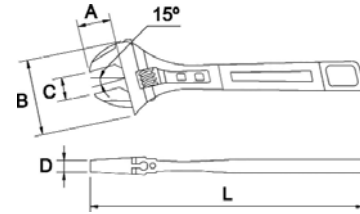

| COD | L | A | B | C | D | W | B | R |
|-------|-----|----|----|------|------|-----|----|---|
| 61136 | 4" | 13 | 34 | 13 | 5,6 | 70 | 10 | 1 |
| 61117 | 6" | 20 | 47 | 19 | 6,5 | 160 | | |
| 61118 | 8" | 25 | 57 | 24 | 7,2 | 310 | | |
| 61119 | 10" | 30 | 70 | 29 | 8,4 | 550 | | |
| 61120 | 12" | 35 | 84 | 33,5 | 10,2 | 850 | 6 | |



| | | | | | | | | |
|-------|-----|------|-----|----|----|------|---|---|
| 61121 | 15" | 44 | 103 | 45 | 13 | 1200 | 1 | 1 |
| 61122 | 18" | 50,5 | 120 | 55 | 14 | 2000 | | |
| 61123 | 24" | 60 | 122 | 62 | 15 | 3100 | | |

FOSFATADA / PHOSPHATED / PHOSPHATEE BRUNIE / PHOSPHATIERT / FINITURA BRUNITA / ZWART / BRUNIDA **COMFORT**

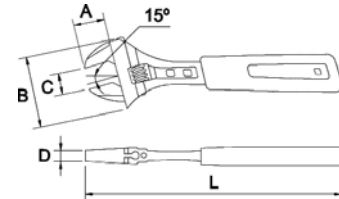

| COD | L | A | B | C | D | W | B | R |
|-------|-----|----|----|------|------|-----|---|---|
| 61898 | 6" | 20 | 47 | 19 | 6,5 | 180 | 6 | 1 |
| 61910 | 8" | 25 | 57 | 24 | 7,2 | 335 | | |
| 61911 | 10" | 30 | 70 | 29 | 8,4 | 595 | | |
| 61912 | 12" | 35 | 84 | 33,5 | 10,2 | 900 | | |



| | | | | | | | | |
|-------|-----|------|-----|----|----|------|---|---|
| 61373 | 15" | 44 | 103 | 45 | 13 | 1250 | 1 | 1 |
| 61374 | 18" | 50,5 | 120 | 55 | 14 | 2050 | | |
| 61375 | 24" | 60 | 122 | 62 | 15 | 3150 | | |

FOSFATADA / PHOSPHATED / PHOSPHATEE BRUNIE / PHOSPHATIERT / FINITURA BRUNITA / ZWART / BRUNIDA **1000V**



1.000V
IEC 900 resp.
DIN EN 60 900

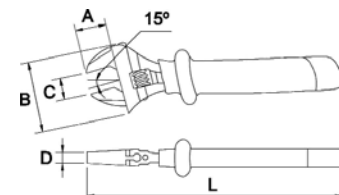

| COD | L | A | B | C | D | W | B | R |
|-------|-----|----|----|------|------|------|---|---|
| 61988 | 6" | 20 | 47 | 19 | 6,5 | 195 | 6 | 1 |
| 61989 | 8" | 25 | 57 | 24 | 7,2 | 370 | | |
| 61990 | 10" | 30 | 70 | 29 | 8,4 | 645 | | |
| 61991 | 12" | 35 | 84 | 33,5 | 10,2 | 1030 | | |

Las ajustables aisladas a 1000V no se pueden homologar ya que la moleta no puede ser aislada, por lo tanto no se puede garantizar la seguridad del usuario, aunque el material aislante cumple la norma EN-60900 en cuanto a resistencia eléctrica.

The insulated adjustable wrenches 1000V can not be homologated as the wheel nut can not be insulated. The safety of the user can not be guaranteed, even though the insulated material fulfills the requirements of the norm EN-60900 regarding the electrical resistance.

Les clés à molette isolées 1000 V ne peuvent être homologuées, la molette ne pouvant être isolée, nous ne pouvons garantir la sécurité de l'utilisateur, malgré que le matériau isolant est conforme à la norme EN-60900 sur la résistance électrique.

ALAVESA / BASQUE / BASKISCH / BASCA / TYPE BASK

PATENTADA / PATENTED / BREVETEE / PATENTIERT / BREVETTATO / GEPATENTERD / PATENTEADA

SISTEMA DE ACCION RAPIDA / QUICK ACTION SYSTEM / ACTION RAPIDE / SCHNELLVERSTELLUNG
SISTEMA DE AZIONE RAPIDA / SNELVSTELLING / SISTEMA DE ACÇÃO RAPIDA

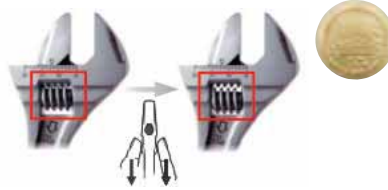

TITACROM®

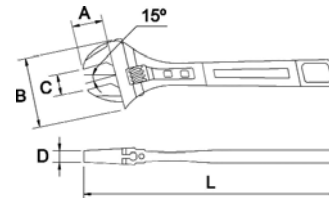

| COD | L | A | B | C | D | Icon 1 | Icon 2 | Icon 3 |
|-------|-----|----|----|------|------|--------|--------|--------|
| 61920 | 6" | 20 | 47 | 19 | 6,5 | 160 | | |
| 61921 | 8" | 25 | 57 | 24 | 7,2 | 310 | 10 | |
| 61922 | 10" | 30 | 70 | 29 | 8,4 | 550 | | 1 |
| 61923 | 12" | 35 | 84 | 33,5 | 10,2 | 850 | 6 | |

TITACROM® COMFORT

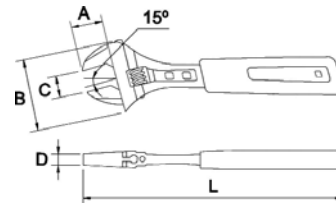

| COD | L | A | B | C | D | Icon 1 | Icon 2 | Icon 3 |
|-------|-----|----|----|------|------|--------|--------|--------|
| 61867 | 6" | 20 | 47 | 19 | 6,5 | 180 | | |
| 61924 | 8" | 25 | 57 | 24 | 7,2 | 335 | | |
| 61925 | 10" | 30 | 70 | 29 | 8,4 | 595 | 6 | 1 |
| 61926 | 12" | 35 | 84 | 33,5 | 10,2 | 900 | | |

TITACROM® 1000V

1.000V
IEC 900 resp.
DIN EN 60 900

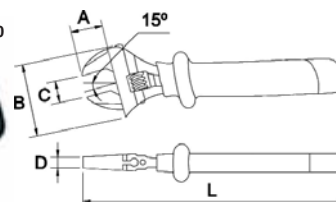

| COD | L | A | B | C | D | Icon 1 | Icon 2 | Icon 3 |
|-------|-----|----|----|------|------|--------|--------|--------|
| 61992 | 6" | 20 | 47 | 19 | 6,5 | 195 | | |
| 61993 | 8" | 25 | 57 | 24 | 7,2 | 370 | | |
| 61994 | 10" | 30 | 70 | 29 | 8,4 | 645 | 6 | 1 |
| 61995 | 12" | 35 | 84 | 33,5 | 10,2 | 1030 | | |

6

LLAVES AJUSTABLES / ADJUSTABLE WRENCHES / CLES A MOLETTE ROLLGABELSCHLÜSSELS / CHIAVI REGOLABILI A RULLINO VERSTELBARE SLEUTELS / CHAVES AJUSTAVELS

ALAVESA / BASQUE / BASKISCH / BASCA / TYPE BASK

PATENTADA / PATENTED / BREVETEE / PATENTIERT / BREVETTATO / GEPATENTERD / PATENTEADA
SISTEMA DE ACCION RAPIDA / QUICK ACTION SYSTEM / ACTION RAPIDE / SCHNELLVERSTELLUNG
SISTEMA DE AZIONE RAPIDA / SNELVERSTELLING / SISTEMA DE ACÇÃO RAPIDA

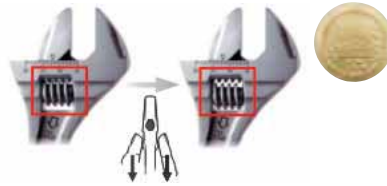

TITACROM®

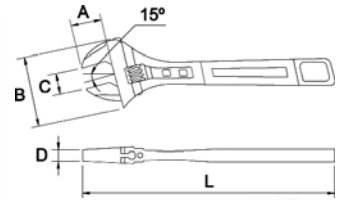

| COD | ← L → | ← A → | ← B → | ← C → | ← D → | | | |
|-------|-------|-------|-------|-------|-------|-----|----|---|
| 61927 | 6" | 20 | 47 | 19 | 6,5 | 160 | 10 | 1 |
| 61928 | 8" | 25 | 57 | 24 | 7,2 | 310 | | |
| 61929 | 10" | 30 | 70 | 29 | 8,4 | 550 | | |
| 61930 | 12" | 35 | 84 | 33,5 | 10,2 | 850 | | |

TITACROM® COMFORT

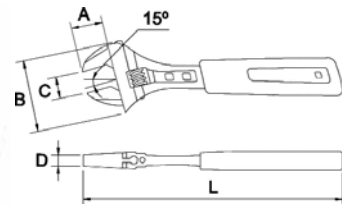

| COD | ← L → | ← A → | ← B → | ← C → | ← D → | | | |
|-------|-------|-------|-------|-------|-------|-----|---|---|
| 61868 | 6" | 20 | 47 | 19 | 6,5 | 180 | 6 | 1 |
| 61931 | 8" | 25 | 57 | 24 | 7,2 | 335 | | |
| 61932 | 10" | 30 | 70 | 29 | 8,4 | 595 | | |
| 61933 | 12" | 35 | 84 | 33,5 | 10,2 | 900 | | |

TITACROM® 1000V

1.000V
IEC 900 resp.
DIN EN 60 900

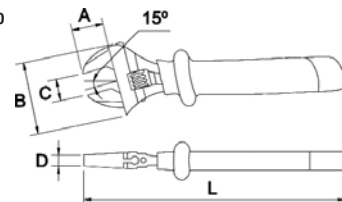

| COD | ← L → | ← A → | ← B → | ← C → | ← D → | | | |
|-------|-------|-------|-------|-------|-------|------|---|---|
| 61996 | 6" | 20 | 47 | 19 | 6,5 | 195 | 6 | 1 |
| 61997 | 8" | 25 | 57 | 24 | 7,2 | 370 | | |
| 61998 | 10" | 30 | 70 | 29 | 8,4 | 645 | | |
| 61999 | 12" | 35 | 84 | 33,5 | 10,2 | 1030 | | |

LLAVE COMBI / WRENCH COMBI / CLE COMBI / ROLLGABELSCHLÜSSEL COMBI



TITACROM®

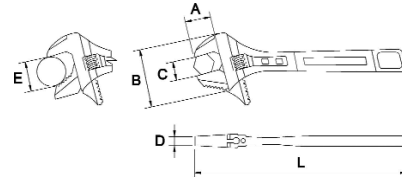

| COD | L | A | B | C | D | E | W | H | U |
|-------|-----|----|------|------|------|-------|-----|----|---|
| 61942 | 10" | 30 | 68,5 | 29 | 8,4 | 1.1/4 | 550 | 10 | 1 |
| 61943 | 12" | 35 | 82 | 33,5 | 10,2 | 1.1/2 | 850 | 6 | 1 |

TITACROM® COMFORT

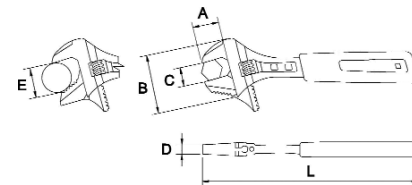

| COD | L | A | B | C | D | E | W | H | U |
|-------|-----|----|------|------|------|-------|-----|---|---|
| 61944 | 10" | 30 | 68,5 | 29 | 8,4 | 1.1/4 | 600 | 6 | 1 |
| 61945 | 12" | 35 | 82 | 33,5 | 10,2 | 1.1/2 | 900 | | |

TITACROM® 1000V

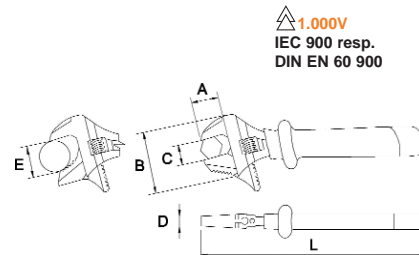

| COD | L | A | B | C | D | E | W | H | U |
|-------|-----|----|------|------|------|-------|------|---|---|
| 61976 | 10" | 30 | 68,5 | 29 | 8,4 | 1.1/4 | 645 | 6 | 1 |
| 61977 | 12" | 35 | 82 | 33,5 | 10,2 | 1.1/2 | 1030 | | |

6

LLAVES AJUSTABLES / ADJUSTABLE WRENCHES / CLES A MOLETTE ROLLGABELSCHLÜSSELS / CHIAVI REGOLABILI A RULLINO VERSTELBARE SLEUTELS / CHAVES AJUSTAVELS

LLAVE COMBI / WRENCH COMBI / CLE COMBI / ROLLGABELSCHLÜSSEL COMBI

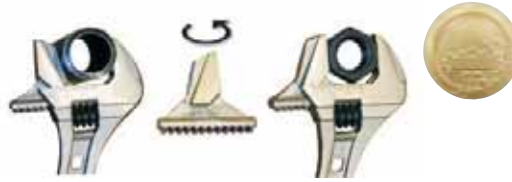

FOSFATADA / PHOSPHATED / PHOSPHATEE BRUNIE / PHOSPHATIERT / FINITURA BRUNITA / ZWART / BRUNIDA



| COD | L | A | B | C | D | E | UF | | |
|-------|-----|----|------|------|------|-------|-----|----|---|
| 61946 | 10" | 30 | 68,5 | 29 | 8,4 | 1.1/4 | 550 | 10 | 1 |
| 61947 | 12" | 35 | 82 | 33,5 | 10,2 | 1.1/2 | 850 | 6 | 1 |

FOSFATADA / PHOSPHATED / PHOSPHATEE BRUNIE / PHOSPHATIERT / FINITURA BRUNITA / ZWART / BRUNIDA **COMFORT**



| COD | L | A | B | C | D | E | UF | | |
|-------|-----|----|------|------|------|-------|-----|---|---|
| 61948 | 10" | 30 | 68,5 | 29 | 8,4 | 1.1/4 | 600 | 6 | 1 |
| 61949 | 12" | 35 | 82 | 33,5 | 10,2 | 1.1/2 | 900 | 6 | 1 |

FOSFATADA / PHOSPHATED / PHOSPHATEE BRUNIE / PHOSPHATIERT / FINITURA BRUNITA / ZWART / BRUNIDA **1000V**



| COD | L | A | B | C | D | E | UF | | |
|-------|-----|----|------|------|------|-------|------|---|---|
| 61978 | 10" | 30 | 68,5 | 29 | 8,4 | 1.1/4 | 645 | 6 | 1 |
| 61979 | 12" | 35 | 82 | 33,5 | 10,2 | 1.1/2 | 1030 | 6 | 1 |

Las ajustables aisladas a 1000V no se pueden homologar ya que la moleta no puede ser aislada, por lo tanto no se puede garantizar la seguridad del usuario, aunque el material aislante cumple la norma EN-60900 en cuanto a resistencia eléctrica.

The insulated adjustable wrenches 1000V can not be homologated as the wheel nut can not be insulated. The safety of the user can not be guaranteed, even though the insulated material fulfils the requirements of the norm EN-60900 regarding the electrical resistance.

Les clés à molette isolées 1000 V ne peuvent être homologuées, la molette ne pouvant être isolée, nous ne pouvons garantir la sécurité de l'utilisateur, malgré que le matériau isolant est conforme à la norme EN-60900 sur la résistance électrique.

LLAVES AJUSTABLES / ADJUSTABLE WRENCHES / CLES A MOLETTE ROLLGABELSCHLÜSSEL / CHIAVI REGOLABILI A RULLINO VERSTELBARE SLEUTELS / CHAVES AJUSTAVELS



ALAVESA COMBI / BASQUE COMBI / BASKISCH KOMBI / BASCA COMBI / TYPE BASK COMBI

PATENTADA / PATENTED / BREVETEE / PATENTIERT / BREVETTATO / GEPATENTERD / PATENTEADA

SISTEMA DE ACCION RAPIDA / QUICK ACTION SYSTEM / ACTION RAPIDE / SCHNELLVERSTELLUNG
SISTEMA DE AZIONE RAPIDA / SNELVSTELLING / SISTEMA DE ACÇÃO RAPIDA



TITACROM®

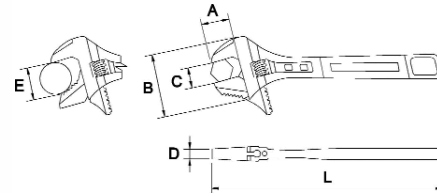

| COD | L | A | B | C | D | E | IP | W | U |
|-------|-----|----|------|------|------|-------|-----|----|---|
| 61934 | 10" | 30 | 68,5 | 29 | 8,4 | 1.1/4 | 550 | 10 | 1 |
| 61935 | 12" | 35 | 82 | 33,5 | 10,2 | 1.1/2 | 850 | 6 | 1 |

TITACROM® COMFORT

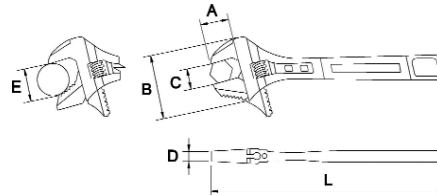

| COD | L | A | B | C | D | E | IP | W | U |
|-------|-----|----|------|------|------|-------|-----|---|---|
| 61936 | 10" | 30 | 68,5 | 29 | 8,4 | 1.1/4 | 600 | 6 | 1 |
| 61937 | 12" | 35 | 82 | 33,5 | 10,2 | 1.1/2 | 900 | 6 | 1 |

TITACROM® 1000V

1.000V
IEC 900 resp.
DIN EN 60 900

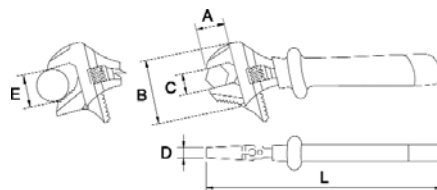

| COD | L | A | B | C | D | E | IP | W | U |
|-------|-----|----|------|------|------|-------|------|---|---|
| 61128 | 10" | 30 | 68,5 | 29 | 8,4 | 1.1/4 | 645 | 6 | 1 |
| 61129 | 12" | 35 | 82 | 33,5 | 10,2 | 1.1/2 | 1030 | 6 | 1 |

6

LLAVES AJUSTABLES / ADJUSTABLE WRENCHES / CLES A MOLETTE ROLLGABELSCHLÜSSELS / CHIAVI REGOLABILI A RULLINO VERSTELBARE SLEUTELS / CHAVES AJUSTAVELS

ALAVESA COMBI / BASQUE COMBI / BASKISCH KOMBI / BASCA COMBI / TYPE BASK COMBI

PATENTADA / PATENTED / BREVETEE / PATENTIERT / BREVETTATO / GEPATENTERD / PATENTEADA

SISTEMA DE ACCION RAPIDA / QUICK ACTION SYSTEM / ACTION RAPIDE / SCHNELLVERSTELLUNG
SISTEMA DE AZIONE RAPIDA / SNELVSTELLING / SISTEMA DE ACÇÃO RAPIDA



FOSFATADA / PHOSPHATED / PHOSPHATEE BRUNIE / PHOSPHATIERT / FINITURA BRUNITA / ZWART / BRUNIDA



| COD | L | A | B | C | D | E | Ph | Zn | Coin |
|-------|-----|----|------|------|------|-------|-----|----|------|
| 61938 | 10" | 30 | 68,5 | 29 | 8,4 | 1.1/4 | 550 | 10 | 1 |
| 61939 | 12" | 35 | 82 | 33,5 | 10,2 | 1.1/2 | 850 | 6 | 1 |

FOSFATADA / PHOSPHATED / PHOSPHATEE BRUNIE / PHOSPHATIERT / FINITURA BRUNITA / ZWART / BRUNIDA **COMFORT**



| COD | L | A | B | C | D | E | Ph | Zn | Coin |
|-------|-----|----|------|------|------|-------|-----|----|------|
| 61940 | 10" | 30 | 68,5 | 29 | 8,4 | 1.1/4 | 600 | 6 | 1 |
| 61941 | 12" | 35 | 82 | 33,5 | 10,2 | 1.1/2 | 900 | 6 | 1 |

FOSFATADA / PHOSPHATED / PHOSPHATEE BRUNIE / PHOSPHATIERT / FINITURA BRUNITA / ZWART / BRUNIDA **1000V**



| COD | L | A | B | C | D | E | Ph | Zn | Coin |
|-------|-----|----|------|------|------|-------|------|----|------|
| 61130 | 10" | 30 | 68,5 | 29 | 8,4 | 1.1/4 | 645 | 6 | 1 |
| 61131 | 12" | 35 | 82 | 33,5 | 10,2 | 1.1/2 | 1030 | 6 | 1 |

Las ajustables aisladas a 1000V no se pueden homologar ya que la molette no puede ser aislada, por lo tanto no se puede garantizar la seguridad del usuario, aunque el material aislante cumple la norma EN-60900 en cuanto a resistencia eléctrica.

The insulated adjustable wrenches 1000V can not be homologated as the wheel nut can not be insulated. The safety of the user can not be guaranteed, even though the insulated material fulfils the requirements of the norm EN-60900 regarding the electrical resistance.

Les clés à molette isolées 1000 V ne peuvent être homologuées, la molette ne pouvant être isolée, nous ne pouvons garantir la sécurité de l'utilisateur, malgré que le matériau isolant est conforme à la norme EN-60900 sur la résistance électrique.

LLAVES AJUSTABLES / ADJUSTABLE WRENCHES / CLES A MOLETTE / ROLLGABELSCHLÜSSEL

PLUMBINGWRENCH

AJUSTABLES GRAN APERTURA / WIDE OPENING ADJUSTABLES / CLE A MOLETTE GRAND OUVERTURE / ROLLGABELSCHLÜSSEL-MIT WEITER OFFNUNG / REGOLABILE APERTURA GRANDE / VERSTELBARE SLEUTEL, GROTE OPENING / AJUSTÁVEL GRANDE ABERTURA



TITACROM®

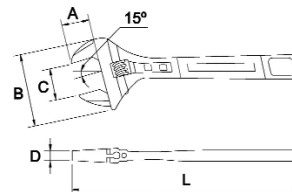

| COD | L | A | B | C | D | W | H | U |
|-------|----|----|----|------|-----|-----|----|---|
| 61229 | 6" | 28 | 60 | 35,5 | 5,9 | 180 | 6 | 1 |
| 61213 | 8" | 33 | 73 | 41 | 6,3 | 430 | 10 | 1 |

TITACROM® COMFORT

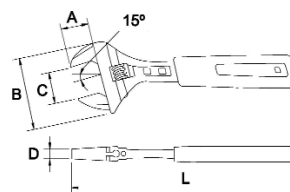

| COD | L | A | B | C | D | W | H | U |
|-------|----|----|----|------|-----|-----|----|---|
| 61230 | 6" | 28 | 60 | 35,5 | 5,9 | 195 | 6 | 1 |
| 61214 | 8" | 33 | 73 | 41 | 6,3 | 450 | 10 | 1 |

FOSFATADA / PHOSPHATED / PHOSPHATEE BRUNIE / PHOSPHATIERT/ FINITURA BRUNITA / ZWART / BRUNIDA

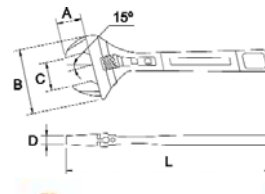

| COD | L | A | B | C | D | W | H | U |
|-------|----|----|----|------|-----|-----|----|---|
| 61231 | 6" | 28 | 60 | 35,5 | 5,9 | 180 | 6 | 1 |
| 61215 | 8" | 33 | 73 | 41 | 6,3 | 430 | 10 | 1 |

FOSFATADA / PHOSPHATED / PHOSPHATEE BRUNIE / PHOSPHATIERT / FINITURA BRUNITA / ZWART / BRUNIDA **COMFORT**

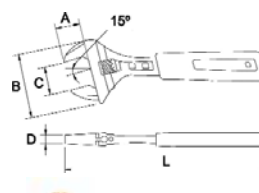

| COD | L | A | B | C | D | W | H | U |
|-------|----|----|----|------|-----|-----|----|---|
| 61232 | 6" | 28 | 60 | 35,5 | 5,9 | 195 | 6 | 1 |
| 61216 | 8" | 33 | 73 | 41 | 6,3 | 450 | 10 | 1 |

LLAVES AJUSTABLES / ADJUSTABLE WRENCHES / CLES A MOLETTE ROLLGABELSCHLÜSSELS / CHIAVI REGOLABILI A RULLINO VERSTELBARE SLEUTELS / CHAVES AJUSTAVELS

ALAVESA / BASQUE / BASKISCH / BASCA / TYPE BASK

BASQUE PLUMBINGWRENCH

PATENTADA / PATENTED / BREVETEE / PATENTIERT / BREVETTATO / GEPATENTERD / PATENTEADA

SISTEMA DE ACCION RAPIDA / QUICK ACTION SYSTEM / ACTION RAPIDE / SCHNELLVERSTELLUNG

SISTEMA DE AZIONE RAPIDA / SNELVSTELLING / SISTEMA DE ACÇÃO RAPIDA

TITACROM®

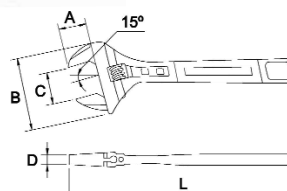
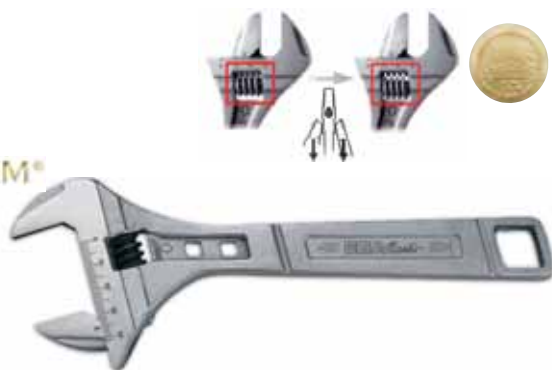

| COD | L | A | B | C | D | gr. | mm | mm |
|-------|----|----|----|------|-----|-----|----|----|
| 61233 | 6" | 28 | 60 | 35,5 | 5,9 | 180 | 6 | 1 |
| 61217 | 8" | 33 | 73 | 41 | 6,3 | 430 | 10 | 1 |

TITACROM® COMFORT

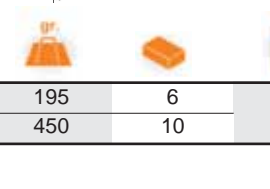
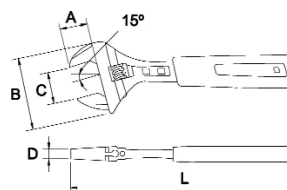

| COD | L | A | B | C | D | gr. | mm | mm |
|-------|----|----|----|------|-----|-----|----|----|
| 61234 | 6" | 28 | 60 | 35,5 | 5,9 | 195 | 6 | 1 |
| 61218 | 8" | 33 | 73 | 41 | 6,3 | 450 | 10 | 1 |

FOSFATADA / PHOSPHATED / PHOSPHATEE BRUNIE / PHOSPHATIERT/ FINITURA BRUNITA / ZWART / BRUNIDA

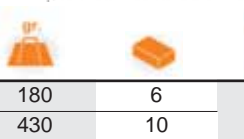
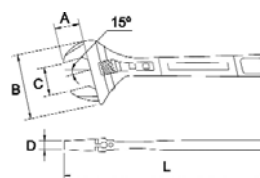

| COD | L | A | B | C | D | gr. | mm | mm |
|-------|----|----|----|------|-----|-----|----|----|
| 61235 | 6" | 28 | 60 | 35,5 | 5,9 | 180 | 6 | 1 |
| 61219 | 8" | 33 | 73 | 41 | 6,3 | 430 | 10 | 1 |

FOSFATADA / PHOSPHATED / PHOSPHATEE BRUNIE / PHOSPHATIERT / FINITURA BRUNITA / ZWART / BRUNIDA

COMFORT

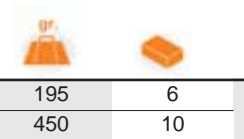
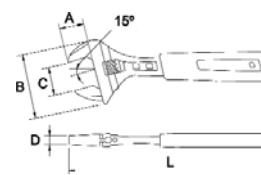

| COD | L | A | B | C | D | gr. | mm | mm |
|-------|----|----|----|------|-----|-----|----|----|
| 61236 | 6" | 28 | 60 | 35,5 | 5,9 | 195 | 6 | 1 |
| 61220 | 8" | 33 | 73 | 41 | 6,3 | 450 | 10 | 1 |

LLAVE COMBI / WRENCH COMBI / CLE COMBI / ROLLGABELSCHLÜSSEL COMBI

COMBI PLUMBINGWRENCH

PATENTADA / PATENTED / BREVETEE / PATENTIERT / BREVETTATO / GEPATENTERD / PATENTEADA

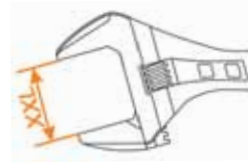

TITACROM®

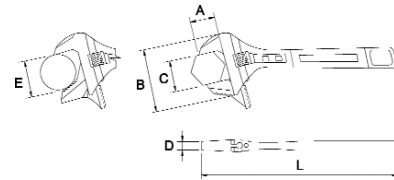

| COD | L | A | B | C | D | E | IP | IP | IP |
|-------|----|----|----|----|-----|-------|-----|----|----|
| 61237 | 8" | 33 | 73 | 41 | 6,3 | 1.1/4 | 430 | 10 | 1 |

TITACROM® COMFORT

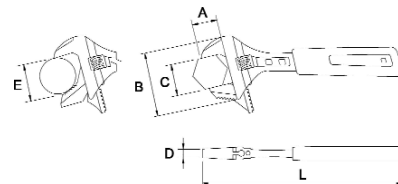

| COD | L | A | B | C | D | E | IP | IP | IP |
|-------|----|----|----|----|-----|-------|-----|----|----|
| 61238 | 8" | 33 | 73 | 41 | 6,3 | 1.1/4 | 450 | 10 | 1 |

FOSFATADA / PHOSPHATED / PHOSPHATEE BRUNIE / PHOSPHATIERT / FINITURA BRUNITA / ZWART / BRUNIDA

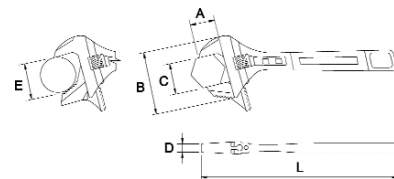

| COD | L | A | B | C | D | E | IP | IP | IP |
|-------|----|----|----|----|-----|-------|-----|----|----|
| 61239 | 8" | 33 | 73 | 41 | 6,3 | 1.1/4 | 430 | 10 | 1 |

FOSFATADA / PHOSPHATED / PHOSPHATEE BRUNIE / PHOSPHATIERT / FINITURA BRUNITA / ZWART / BRUNIDA **COMFORT**

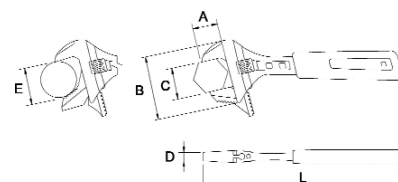

| COD | L | A | B | C | D | E | IP | IP | IP |
|-------|----|----|----|----|-----|-------|-----|----|----|
| 61240 | 8" | 33 | 73 | 41 | 6,3 | 1.1/4 | 450 | 10 | 1 |

LLAVES AJUSTABLES / ADJUSTABLE WRENCHES / CLES A MOLETTE ROLLGABELSCHLÜSSELS / CHIAVI REGOLABILI A RULLINO VERSTELBARE SLEUTELS / CHAVES AJUSTAVELS

ALAVESA COMBI / BASQUE COMBI / BASKISCH KOMBI / BASCA COMBI / TYPE BASK COMBI

BASQUE COMBI PLUMBINGWRENCH

PATENTADA / PATENTED / BREVETEE / PATENTIERT / BREVETTATO / GEPATENTERD / PATENTEADA

SISTEMA DE ACCION RAPIDA / QUICK ACTION SYSTEM / ACTION RAPIDE / SCHNELLVERSTELLUNG

SISTEMA DE AZIONE RAPIDA / SNELVSTELLING / SISTEMA DE ACÇÃO RAPIDA



TITACROM®

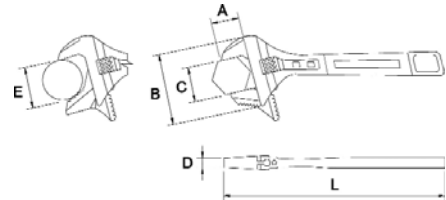

| COD | L | A | B | C | D | E | UP | W | H |
|-------|----|----|----|----|-----|-------|-----|----|---|
| 61221 | 8" | 33 | 73 | 41 | 6,3 | 1.1/4 | 430 | 10 | 1 |

TITACROM® COMFORT

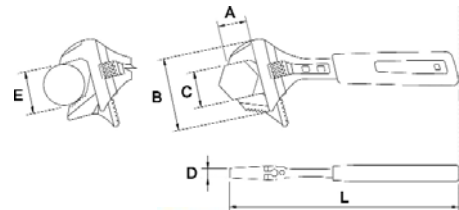

| COD | L | A | B | C | D | E | UP | W | H |
|-------|----|----|----|----|-----|-------|-----|----|---|
| 61222 | 8" | 33 | 73 | 41 | 6,3 | 1.1/4 | 450 | 10 | 1 |

FOSFATADA / PHOSPHATED / PHOSPHATEE BRUNIE / PHOSPHATIERT / FINITURA BRUNITA / ZWART / BRUNIDA

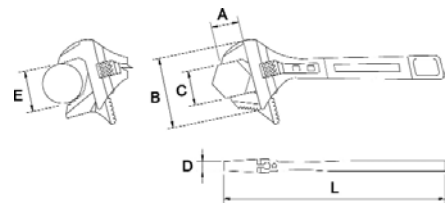

| COD | L | A | B | C | D | E | UP | W | H |
|-------|----|----|----|----|-----|-------|-----|----|---|
| 61223 | 8" | 33 | 73 | 41 | 6,3 | 1.1/4 | 430 | 10 | 1 |

FOSFATADA / PHOSPHATED / PHOSPHATEE BRUNIE / PHOSPHATIERT / FINITURA BRUNITA / ZWART / BRUNIDA **COMFORT**

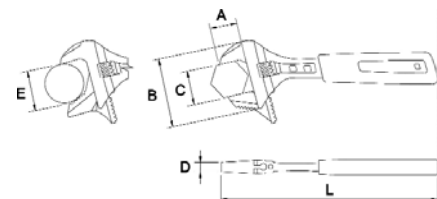

| COD | L | A | B | C | D | E | UP | W | H |
|-------|----|----|----|----|-----|-------|-----|----|---|
| 61224 | 8" | 33 | 73 | 41 | 6,3 | 1.1/4 | 450 | 10 | 1 |

Las ajustables aisladas a 1000V no se pueden homologar ya que la molette no puede ser aislada, por lo tanto no se puede garantizar la seguridad del usuario, aunque el material aislante cumple la norma EN-60900 en cuanto a resistencia eléctrica.

The insulated adjustable wrenches 1000V can not be homologated as the wheel nut can not be insulated. The safety of the user can not be guaranteed, even though the insulated material fulfils the requirements of the norm EN-60900 regarding the electrical resistance.

Les clés à molette isolées 1000 V ne peuvent être homologuées, la molette ne pouvant être isolée, nous ne pouvons garantir la sécurité de l'utilisateur, malgré que le matériau isolant est conforme à la norme EN-60900 sur la résistance électrique.

LLAVES AJUSTABLES / ADJUSTABLE WRENCHES / CLES A MOLETTE / ROLLGABELSCHLÜSSEL
 SCANDINAVIAN TYPE / LEFT TURN

FOSFATADA / PHOSPHATED / PHOSPHATEE BRUNIE / PHOSPHATIERT / FINITURA BRUNITA / ZWART / BRUNIDA

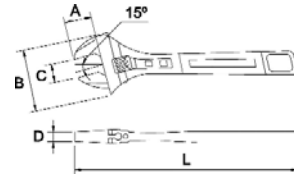

| COD | L | A | B | C | D | WF | | |
|-------|-----|------|-----|------|------|------|----|---|
| 60549 | 4" | 13 | 34 | 13 | 5,6 | 70 | | |
| 60550 | 6" | 20 | 47 | 19 | 6,5 | 160 | 10 | |
| 60551 | 8" | 25 | 57 | 24 | 7,2 | 310 | | 1 |
| 60552 | 10" | 30 | 70 | 29 | 8,4 | 550 | | |
| 60553 | 12" | 35 | 84 | 33,5 | 10,2 | 850 | 6 | |
| 60554 | 15" | 44 | 103 | 45 | 13 | 1200 | | |
| 60555 | 18" | 50,5 | 120 | 55 | 14 | 2000 | 1 | 1 |
| 60556 | 24" | 60 | 122 | 62 | 15 | 3100 | | |

FOSFATADA / PHOSPHATED / PHOSPHATEE BRUNIE / PHOSPHATIERT / FINITURA BRUNITA / ZWART / BRUNIDA

COMFORT

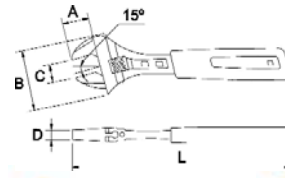

| COD | L | A | B | C | D | WF | | |
|-------|-----|------|-----|------|------|------|---|---|
| 60548 | 6" | 20 | 47 | 19 | 6,5 | 180 | | |
| 60557 | 8" | 25 | 57 | 24 | 7,2 | 335 | 6 | 1 |
| 60558 | 10" | 30 | 70 | 29 | 8,4 | 595 | | |
| 60559 | 12" | 35 | 84 | 33,5 | 10,2 | 900 | | |
| 60560 | 15" | 44 | 103 | 45 | 13 | 1200 | | |
| 60561 | 18" | 50,5 | 120 | 55 | 14 | 2000 | 1 | 1 |
| 60562 | 24" | 60 | 122 | 62 | 15 | 3150 | | |

FOSFATADA / PHOSPHATED / PHOSPHATEE BRUNIE / PHOSPHATIERT / FINITURA BRUNITA / ZWART / BRUNIDA

1000V



1.000V
 IEC 900 resp.
 DIN EN 60 900

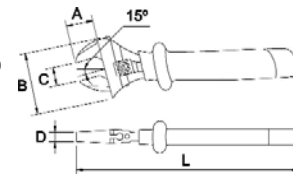

| COD | L | A | B | C | D | WF | | |
|-------|-----|----|----|------|------|------|---|---|
| 60563 | 6" | 20 | 47 | 19 | 6,5 | 195 | | |
| 60564 | 8" | 25 | 57 | 24 | 7,2 | 370 | 6 | 1 |
| 60565 | 10" | 30 | 70 | 29 | 8,4 | 645 | | |
| 60566 | 12" | 35 | 84 | 33,5 | 10,2 | 1030 | | |

LLAVES AJUSTABLES / ADJUSTABLE WRENCHES / CLES A MOLETTE ROLLGABELSCHLÜSSELS / CHIAVI REGOLABILI A RULLINO VERSTELBARE SLEUTELS / CHAVES AJUSTAVELS

ALAVESA / BASQUE / BASKISCH / BASCA / TYPE BASK

BASQUE SCANDINAVIAN TYPE / LEFT TURN

PATENTADA / PATENTED / BREVETEE / PATENTIERT / BREVETTATO / GEPATENTERD / PATENTEADA

SISTEMA DE ACCION RAPIDA / QUICK ACTION SYSTEM / ACTION RAPIDE / SCHNELLVERSTELLUNG
SISTEMA DE AZIONE RAPIDA / SNEELVERSTELLING / SISTEMA DE ACÇÃO RAPIDA



FOSFATADA / PHOSPHATED / PHOSPHATEE BRUNIE / PHOSPHATIERT / FINITURA BRUNITA / ZWART / BRUNIDA

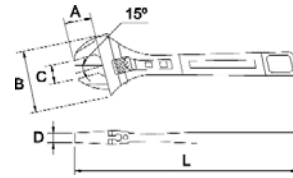

| COD | L | A | B | C | D | W | W | W |
|-------|-----|----|----|------|------|-----|---|---|
| 60567 | 6" | 20 | 47 | 19 | 6,5 | 160 | | |
| 60568 | 8" | 25 | 57 | 24 | 7,2 | 310 | | |
| 60569 | 10" | 30 | 70 | 29 | 8,4 | 550 | 6 | 1 |
| 60570 | 12" | 35 | 84 | 33,5 | 10,2 | 850 | | |

FOSFATADA / PHOSPHATED / PHOSPHATEE BRUNIE / PHOSPHATIERT / FINITURA BRUNITA / ZWART / BRUNIDA

COMFORT

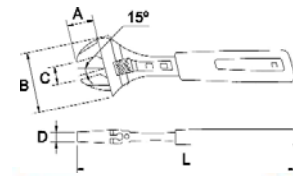

| COD | L | A | B | C | D | W | W | W |
|-------|-----|----|----|------|------|-----|---|---|
| 60547 | 6" | 20 | 47 | 19 | 6,5 | 180 | | |
| 60571 | 8" | 25 | 57 | 24 | 7,2 | 335 | | |
| 60572 | 10" | 30 | 70 | 29 | 8,4 | 595 | 6 | 1 |
| 60573 | 12" | 35 | 84 | 33,5 | 10,2 | 900 | | |

FOSFATADA / PHOSPHATED / PHOSPHATEE BRUNIE / PHOSPHATIERT / FINITURA BRUNITA / ZWART / BRUNIDA

1000V



▲1.000V
IEC 900 resp.
DIN EN 60 900

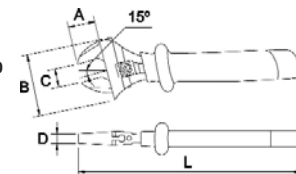

| COD | L | A | B | C | D | W | W | W |
|-------|-----|----|----|------|------|------|---|---|
| 60574 | 6" | 20 | 47 | 19 | 6,5 | 195 | | |
| 60575 | 8" | 25 | 57 | 24 | 7,2 | 370 | | |
| 60576 | 10" | 30 | 70 | 29 | 8,4 | 645 | 6 | 1 |
| 60577 | 12" | 35 | 84 | 33,5 | 10,2 | 1030 | | |

Las ajustables aisladas a 1000V no se pueden homologar ya que la molette no puede ser aislada, por lo tanto no se puede garantizar la seguridad del usuario, aunque el material aislante cumple la norma EN-60900 en cuanto a resistencia eléctrica.

The insulated adjustable wrenches 1000V can not be homologated as the wheel nut can not be insulated. The safety of the user can not be guaranteed, even though the insulated material fulfils the requirements of the norm EN-60900 regarding the electrical resistance.

Les clés à molette isolées 1000 V ne peuvent être homologuées, la molette ne pouvant être isolée, nous ne pouvons garantir la sécurité de l'utilisateur, malgré que le matériau isolant est conforme à la norme EN-60900 sur la résistance électrique.

LLAVE COMBI / WRENCH COMBI / CLE COMBI / ROLLGABELSCHLÜSSEL COMBI

COMBI SCANDINAVIAN TYPE / LEFT TURN

PATENTADA / PATENTED / BREVETEE / PATENTIERT / BREVETTATO / GEPATENTERD / PATENTEADA



FOSFATADA / PHOSPHATED / PHOSPHATEE BRUNIE / PHOSPHATIERT / FINITURA BRUNITA / ZWART / BRUNIDA

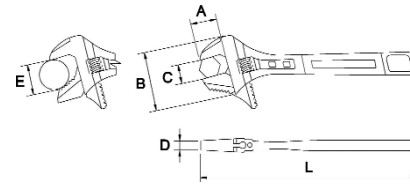

| COD | L | A | B | C | D | E | IP | 6 | 1 |
|-------|-----|----|------|------|------|-------|-----|---|---|
| 61241 | 10" | 30 | 68,5 | 29 | 8,4 | 1.1/4 | 550 | 6 | 1 |
| 61242 | 12" | 35 | 82 | 33,5 | 10,2 | 1.1/2 | 850 | 6 | 1 |

FOSFATADA / PHOSPHATED / PHOSPHATEE BRUNIE / PHOSPHATIERT / FINITURA BRUNITA / ZWART / BRUNIDA **COMFORT**

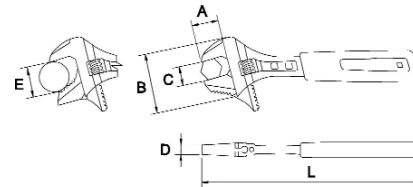

| COD | L | A | B | C | D | E | IP | 6 | 1 |
|-------|-----|----|------|------|------|-------|-----|---|---|
| 61243 | 10" | 30 | 68,5 | 29 | 8,4 | 1.1/4 | 600 | 6 | 1 |
| 61244 | 12" | 35 | 82 | 33,5 | 10,2 | 1.1/2 | 900 | 6 | 1 |

FOSFATADA / PHOSPHATED / PHOSPHATEE BRUNIE / PHOSPHATIERT / FINITURA BRUNITA / ZWART / BRUNIDA **1000V**



1.000V
IEC 900 resp.
DIN EN 60 900

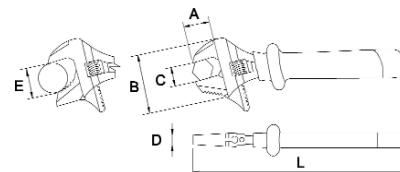

| COD | L | A | B | C | D | E | IP | 6 | 1 |
|-------|-----|----|------|------|------|-------|------|---|---|
| 61245 | 10" | 30 | 68,5 | 29 | 8,4 | 1.1/4 | 645 | 6 | 1 |
| 61246 | 12" | 35 | 82 | 33,5 | 10,2 | 1.1/2 | 1030 | 6 | 1 |

6

LLAVES AJUSTABLES / ADJUSTABLE WRENCHES / CLES A MOLETTE ROLLGABELSCHLÜSSELS / CHIAVI REGOLABILI A RULLINO VERSTELBARE SLEUTELS / CHAVES AJUSTAVELS

ALAVESA COMBI / BASQUE COMBI / BASKISCH KOMBI / BASCA COMBI / TYPE BASK COMBI

BASQUE COMBI SCANDINAVIAN TYPE / LEFT TURN

PATENTADA / PATENTED / BREVETEE / PATENTIERT / BREVETTATO / GEPATENTERD / PATENTEADA
SISTEMA DE ACCION RAPIDA / QUICK ACTION SYSTEM / ACTION RAPIDE / SCHNELLVERSTELLUNG
SISTEMA DE AZIONE RAPIDA / SNEELVERSTELLING / SISTEMA DE ACÇÃO RAPIDA



FOSFATADA / PHOSPHATED / PHOSPHATEE BRUNIE / PHOSPHATIERT / FINITURA BRUNITA / ZWART / BRUNIDA

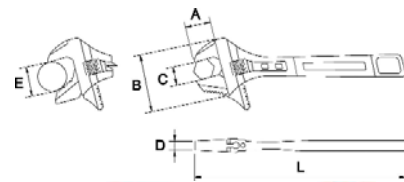

| COD | L | A | B | C | D | E | W | W | W |
|-------|-----|----|------|------|------|-------|-----|---|---|
| 60584 | 10" | 30 | 68,5 | 29 | 8,4 | 1.1/4 | 550 | 6 | 1 |
| 60585 | 12" | 35 | 82 | 33,5 | 10,2 | 1.1/2 | 850 | 6 | 1 |

FOSFATADA / PHOSPHATED / PHOSPHATEE BRUNIE / PHOSPHATIERT / FINITURA BRUNITA / ZWART / BRUNIDA **COMFORT**

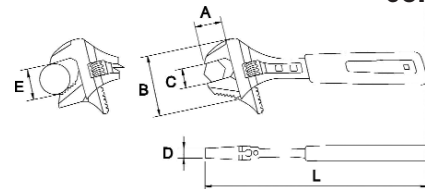

| COD | L | A | B | C | D | E | W | W | W |
|-------|-----|----|------|------|------|-------|-----|---|---|
| 60586 | 10" | 30 | 68,5 | 29 | 8,4 | 1.1/4 | 600 | 6 | 1 |
| 60587 | 12" | 35 | 82 | 33,5 | 10,2 | 1.1/2 | 900 | 6 | 1 |

FOSFATADA / PHOSPHATED / PHOSPHATEE BRUNIE / PHOSPHATIERT / FINITURA BRUNITA / ZWART / BRUNIDA **1000V**



1.000V
IEC 900 resp.
DIN EN 60 900

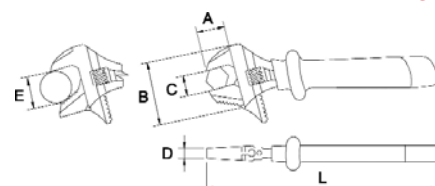

| COD | L | A | B | C | D | E | W | W | W |
|-------|-----|----|------|------|------|-------|------|---|---|
| 60588 | 10" | 30 | 68,5 | 29 | 8,4 | 1.1/4 | 645 | 6 | 1 |
| 60589 | 12" | 35 | 82 | 33,5 | 10,2 | 1.1/2 | 1030 | 6 | 1 |

Las ajustables aisladas a 1000V no se pueden homologar ya que la molette no puede ser aislada, por lo tanto no se puede garantizar la seguridad del usuario, aunque el material aislante cumple la norma EN-60900 en cuanto a resistencia eléctrica.

The insulated adjustable wrenches 1000V can not be homologated as the wheel nut can not be insulated. The safety of the user can not be guaranteed, even though the insulated material fulfills the requirements of the norm EN-60900 regarding the electrical resistance.

Les clés à molette isolées 1000 V ne peuvent être homologuées, la molette ne pouvant être isolée, nous ne pouvons garantir la sécurité de l'utilisateur, malgré que le matériau isolant est conforme à la norme EN-60900 sur la résistance électrique.

**LLAVES AJUSTABLES / ADJUSTABLE WRENCHES / CLES A MOLETTE / ROLLGABELSCHLÜSSEL
SCANDINAVIAN TYPE PLUMBINGWRENCH / LEFT TURN**

AJUSTABLES GRAN APERTURA / WIDE OPENING ADJUSTABLES / CLE A MOLETTE GRAND OUVERTURE / ROLLGABELSCHLÜSSEL-MIT WEITER OFFNUNG / REGOLABILE APERTURA GRANDE / VERSTELBARE SLEUTEL, GROTE OPENING / AJUSTÁVEL GRANDE ABERTURA



FOSFATADA / PHOSPHATED / PHOSPHATEE BRUNIE / PHOSPHATIERT / FINITURA BRUNITA / ZWART / BRUNIDA

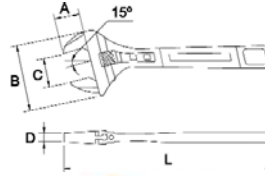

| COD | L | A | B | C | D | UF | UF | UF |
|-------|----|----|------|------|-----|-----|----|----|
| 61248 | 6" | 28 | 39,6 | 35,5 | 5,9 | 180 | 6 | 1 |
| 61252 | 8" | 33 | 73 | 41 | 6,3 | 430 | 10 | 1 |

FOSFATADA / PHOSPHATED / PHOSPHATEE BRUNIE / PHOSPHATIERT / FINITURA BRUNITA / ZWART / BRUNIDA **COMFORT**

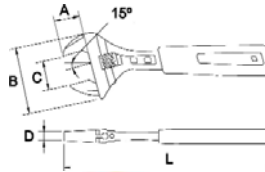

| COD | L | A | B | C | D | UF | UF | UF |
|-------|----|----|------|------|-----|-----|----|----|
| 61249 | 6" | 28 | 39,6 | 35,5 | 5,9 | 195 | 6 | 1 |
| 61253 | 8" | 33 | 73 | 41 | 6,3 | 450 | 10 | 1 |

ALAVESA / BASQUE / BASKISCH / BASCA / TYPE BASK

BASQUE SCANDINAVIAN TYPE PLUMBINGWRENCH / LEFT TURN

PATENTADA / PATENTED / BREVETEE / PATENTIERT / BREVETTATO / GEPATENTERD / PATENTEADA

SISTEMA DE ACCION RAPIDA / QUICK ACTION SYSTEM / ACTION RAPIDE / SCHNELLVERSTELLUNG

SISTEMA DE AZIONE RAPIDA / SNELVSTELLING / SISTEMA DE ACÇÃO RAPIDA



FOSFATADA / PHOSPHATED / PHOSPHATEE BRUNIE / PHOSPHATIERT / FINITURA BRUNITA / ZWART / BRUNIDA

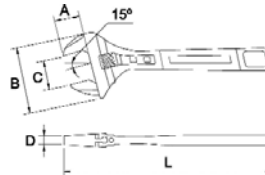

| COD | L | A | B | C | D | UF | UF | UF |
|-------|----|----|------|------|-----|-----|----|----|
| 61250 | 6" | 28 | 39,6 | 35,5 | 5,9 | 180 | 6 | 1 |
| 61254 | 8" | 33 | 73 | 41 | 6,3 | 430 | 10 | 1 |

FOSFATADA / PHOSPHATED / PHOSPHATEE BRUNIE / PHOSPHATIERT / FINITURA BRUNITA / ZWART / BRUNIDA **COMFORT**

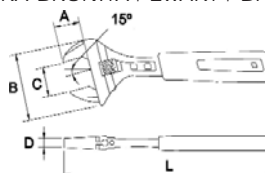

| COD | L | A | B | C | D | UF | UF | UF |
|-------|----|----|------|------|-----|-----|----|----|
| 61251 | 6" | 28 | 39,6 | 35,5 | 5,9 | 195 | 6 | 1 |
| 61255 | 8" | 33 | 73 | 41 | 6,3 | 450 | 10 | 1 |

**LLAVES AJUSTABLES / ADJUSTABLE WRENCHES / CLES A MOLETTE
ROLLGABELSCHLÜSSEL / CHIAVI REGOLABILI A RULLINO
VERSTELBARE SLEUTELS / CHAVES AJUSTAVELS**

LLAVE COMBI / WRENCH COMBI / CLE COMBI / ROLLGABELSCHLÜSSEL COMBI

COMBI SCANDINAVIAN TYPE PLUMBINGWRENCH / LEFT TURN

PATENTADA / PATENTED / BREVETEE / PATENTIERT / BREVETTATO / GEPATENTERD / PATENTEADA



FOSFATADA / PHOSPHATED / PHOSPHATEE BRUNIE / PHOSPHATIERT / FINITURA BRUNITA / ZWART / BRUNIDA

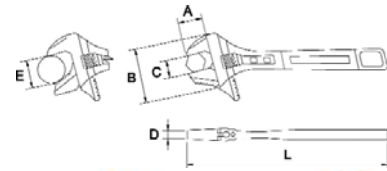

| | | | | | | | | | |
|------------|-------|-------|-------|-------|-------|-------|-----|----|---|
| COD | ← L → | ← A → | ← B → | ← C → | ← D → | ← E → | | | |
| 61256 | 8" | 25 | 57 | 24 | 7,2 | 1.1/4 | 430 | 10 | 1 |

FOSFATADA / PHOSPHATED / PHOSPHATEE BRUNIE / PHOSPHATIERT / FINITURA BRUNITA / ZWART / BRUNIDA **ComFORT**

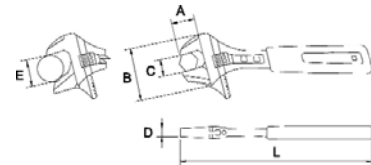

| | | | | | | | | | |
|------------|-------|-------|-------|-------|-------|-------|-----|----|---|
| COD | ← L → | ← A → | ← B → | ← C → | ← D → | ← E → | | | |
| 61257 | 8" | 25 | 57 | 24 | 7,2 | 1.1/4 | 450 | 10 | 1 |

ALAVESA COMBI / BASQUE COMBI / BASKISCH KOMBI / BASCA COMBI / TYPE BASK COMBI

BASQUE COMBI SCANDINAVIAN TYPE PLUMBINGWRENCH / LEFT TURN

PATENTADA / PATENTED / BREVETEE / PATENTIERT / BREVETTATO / GEPATENTERD / PATENTEADA

SISTEMA DE ACCION RAPIDA / QUICK ACTION SYSTEM / ACTION RAPIDE / SCHNELLVERSTELLUNG / SISTEMA DE AZIONE RAPIDA / SNEELVERSTELLING / SISTEMA DE ACÇÃO RAPIDA



FOSFATADA / PHOSPHATED / PHOSPHATEE BRUNIE / PHOSPHATIERT / FINITURA BRUNITA / ZWART / BRUNIDA

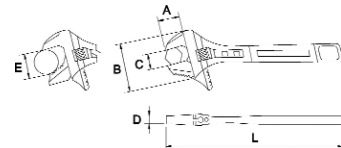

| | | | | | | | | | |
|------------|-------|-------|-------|-------|-------|-------|-----|----|---|
| COD | ← L → | ← A → | ← B → | ← C → | ← D → | ← E → | | | |
| 61258 | 8" | 25 | 57 | 24 | 7,2 | 1.1/4 | 430 | 10 | 1 |

FOSFATADA / PHOSPHATED / PHOSPHATEE BRUNIE / PHOSPHATIERT / FINITURA BRUNITA / ZWART / BRUNIDA **ComFORT**

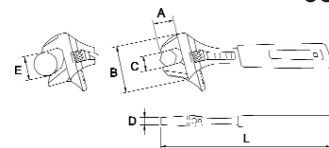

| | | | | | | | | | |
|------------|-------|-------|-------|-------|-------|-------|-----|----|---|
| COD | ← L → | ← A → | ← B → | ← C → | ← D → | ← E → | | | |
| 61259 | 8" | 25 | 57 | 24 | 7,2 | 1.1/4 | 450 | 10 | 1 |

Las ajustables aisladas a 1000V no se pueden homologar ya que la molette no puede ser aislada, por lo tanto no se puede garantizar la seguridad del usuario, aunque el material aislante cumple la norma EN-60900 en cuanto a resistencia eléctrica.

The insulated adjustable wrenches 1000V can not be homologated as the wheel nut can not be insulated. The safety of the user can not be guaranteed, even though the insulated material fulfils the requirements of the norm EN-60900 regarding the electrical resistance.

Les clés à molette isolées 1000 V ne peuvent être homologuées, la molette ne pouvant être isolée, nous ne pouvons garantir la sécurité de l'utilisateur, malgré que le matériau isolant est conforme à la norme EN-60900 sur la résistance électrique.

LLAVES AJUSTABLES / ADJUSTABLE WRENCHES / CLES A MOLETTE / ROLLGABELSCHLÜSSEL

MOLETA LATERAL / LATERAL NUT / MIT SCHNECKENROLLE / MOLETTE LATERALE
 RULLINO LATERALE / ZIJ-INSTELLING

TITACROM®

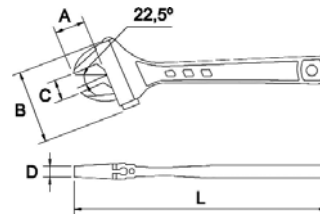

| COD | L | A | B | C | D | W | W | W |
|-------|-----|------|------|------|------|-----|----|---|
| 61057 | 6" | 19,5 | 54,1 | 19 | 8,5 | 180 | 10 | 1 |
| 61058 | 8" | 24 | 64,2 | 24 | 9,5 | 310 | | |
| 61059 | 10" | 30 | 78,5 | 29 | 11,1 | 520 | | |
| 61060 | 12" | 36 | 93,4 | 33,5 | 12,7 | 885 | | |

TITACROM® COMFORT

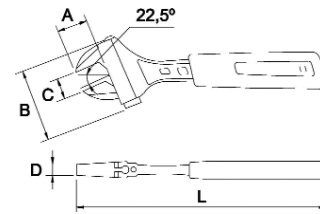

| COD | L | A | B | C | D | W | W | W |
|-------|-----|----|------|------|------|-----|---|---|
| 61061 | 8" | 24 | 64,2 | 24 | 9,5 | 310 | 6 | 1 |
| 61062 | 10" | 30 | 78,5 | 29 | 11,1 | 520 | | |
| 61063 | 12" | 36 | 93,4 | 33,5 | 12,7 | 885 | | |

TITACROM® 1000V



1.000V
 IEC 900 resp.
 DIN EN 60 900

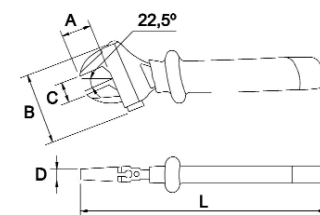

| COD | L | A | B | C | D | W | W | W |
|-------|-----|------|------|------|------|------|---|---|
| 61132 | 6" | 19,5 | 54,1 | 19 | 8,5 | 200 | 6 | 1 |
| 61133 | 8" | 24 | 64,2 | 24 | 9,5 | 400 | | |
| 61134 | 10" | 30 | 78,5 | 29 | 11,1 | 600 | | |
| 61135 | 12" | 36 | 93,4 | 33,5 | 12,7 | 1000 | | |

6



LLAVES AJUSTABLES / ADJUSTABLE WRENCHES / CLES A MOLETTE ROLLGABELSCHLÜSSELS / CHIAVI REGOLABILI A RULLINO VERSTELBARE SLEUTELS / CHAVES AJUSTAVELS

EXPOSITORES / DISPLAYS / PRESENTOIRS / STÄNDER / ESPOSITORE / DISPLAY STAND



UNIQUE PLUS

DIN 3117

UN. **COD:69411**

| | | | |
|---|-------|-----|---|
| 6 | 61110 | 6" |  |
| 9 | 61111 | 8" | |
| 9 | 61112 | 10" |  |
| 6 | 61907 | 8" | |
| 6 | 61908 | 10" | |

UN. **COD:69412**

| | | | |
|---|-------|-----|---|
| 6 | 61117 | 6" |  |
| 9 | 61118 | 8" | |
| 9 | 61119 | 10" |  |
| 6 | 61910 | 8" | |
| 6 | 61911 | 10" | |



UN. **COD:69415**

| | | | |
|---|-------|-----|---|
| 6 | 61110 | 6" |  |
| 6 | 61111 | 8" | |
| 6 | 61112 | 10" | |
| 6 | 61057 | 6" |  |
| 6 | 61058 | 8" | |
| 6 | 61059 | 10" | |



UN. **COD:69435**

| | | | |
|---|-------|-----|---|
| 6 | 61110 | 6" |  |
| 6 | 61111 | 8" | |
| 6 | 61112 | 10" | |
| 6 | 61113 | 12" |  |
| 6 | 61936 | 10" | |
| 6 | 61937 | 12" | |
| 6 | 61057 | 6" |  |
| 6 | 61058 | 8" | |
| 6 | 61059 | 10" | |
| 6 | 61060 | 12" | |
| 6 | 61060 | 12" | |



UN. **COD:69437**

| | | | |
|----|-------|-----|---|
| 6 | 61110 | 6" |  |
| 6 | 61111 | 8" | |
| 12 | 61112 | 10" | |
| 6 | 61113 | 12" |  |
| 6 | 61907 | 8" | |
| 6 | 61908 | 10" | |
| 6 | 61909 | 12" |  |
| 6 | 61936 | 10" | |
| 6 | 61937 | 12" | |

UN. **COD:69439**

| | | | |
|----|-------|-----|---|
| 6 | 61117 | 6" |  |
| 6 | 61118 | 8" | |
| 12 | 61119 | 10" |  |
| 6 | 61120 | 12" | |
| 6 | 61910 | 8" |  |
| 6 | 61911 | 10" | |
| 6 | 61912 | 12" |  |
| 6 | 61940 | 10" | |
| 6 | 61941 | 12" | |



LLAVE COMBINADA REVERSIBLE MASTERGEAR REVERSIBLE MASTERGEAR COMBINATION WRENCH CLÉS MIXTES REVERSIBLES MASTERGEAR

El diseño exclusivo de las llaves MASTERGEAR provee al profesional más exigente de una llave multiuso para el apriete en los lugares de más difícil acceso y con un cómodo sistema de carraca. Fabricadas en Cromo-Vanadio, soportan ampliamente los valores de torsión de los estándares de calidad más exigentes. Su carraca de 72 dientes junto con el diseño especial de su cabeza posibilita aprietes en las posiciones más complicadas, necesitando únicamente 5° para ello. Reversibles, Stubby, E-Torx...todo lo necesario para el profesional.

The exclusive design of the MASTERGEAR Wrenches, provides the demanding professional with an all-in-one wrench for the most difficult access tightening, with a comfortable ratchet system. Made in Chrome Vanadium, they easily stand the most restrictive quality standards for torque. Their 72 teeth gear together with the ratchet head design enables tightening in the narrowest places, with only 5° required for such purpose. Reversible, Stubby, E-Torx...all that the demanding professional may need.

La conception exclusive de la clé MASTERGEAR fournit au professionnel le plus exigeant une clé multi-usages pour le serrage dans des lieux exigus, avec un système de cliquet. Fabriquées en Chrome Vanadium, elles supportent amplement les valeurs de torsion que requièrent les standards de qualité les plus exigeants. Son cliquet de 72 dents, combiné à un dessin spécifique de la tête, permettent des serrages dans les positions les plus complexes, requerrant uniquement 5° pour agir. Réversibles, Stubby, E-Torx...tout l'indispensable pour le professionnel.

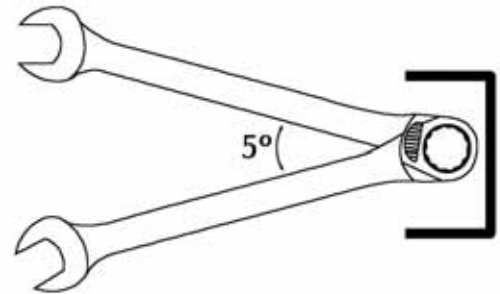

1

1 Nuestro objetivo de fabricar herramientas más eficientes y fáciles de usar, nos ha llevado a diseñar la palanca de cambio HALF-MOON para las llaves combinadas reversibles MASTERGEAR, que evita cambios indeseados y repentinos de dirección de giro durante el uso. Asimismo, está diseñada para evitar el reemplazo prematuro por rotura de palanca, al encontrarse ésta protegida y sin sobresalir del cuerpo de la llave.

Our aim to make more easy-to-be-used and more efficient items, led us to design the newest HALF-MOON switch for the MASTERGEAR Reversible Combination Wrenches, which avoids unwanted or unconscious switch reversing as well as premature damage of the switch.

Notre objectif de fabriquer des outils plus performants et plus aisés d'utilisation, nous a amené à dessiner le bouton de changement de sens de la clé à cliquet réversible MASTERGEAR, en forme de demi-lune, ce qui a pour effet d'éviter des changements de sens indésirables et soudain durant l'utilisation. De même, sa conception permet d'éviter des remplacements prématurés de la clé pour cause de rupture du levier, le bouton étant protégé car ne ressortant pas trop du corps de l'outil.



Su innovador diseño de estrella permite apretar múltiples y diferentes cabezas de tornillo, tales como Spherical, 6-lados, 12 lados, E-torx y Cuadrados, incluso en cabezas redondeadas hasta en un 50% por el desgaste.

Its innovative box drive allows to tighten multiple nut heads such as Spherical, 6-point, 12 point, Square and E-torx, as well as with 50% rounded off nuts.

Son dessin innovateur en étoile, permet de serrer de multiples et différentes têtes de vissage, telles que sphériques, 6 pans, 12 pans, E-Torx et carrées, y compris des têtes arrondies à 50% par usure.

MASTERGEAR REV.

LLAVE COMBINADA DE CARRACA REVERSIBLE MASTERGEAR / REVERSIBLE MASTERGEAR COMBINATION RATCHET WRENCH
 CLE MIXTE A CLIQUET REVERSIBLE MASTERGEAR / RATSCHEN-RINGGABELSCHLÜSSEL, UMKEHRBAR / RATELRINGSLEUTEL MET
 HENDELCHIAVE COMBINATA A CRICCO REVERSIBILE MASTERGEAR / CHAVE DE BOCA E LUNETEA DE ROQUETE REVERSIVEL MASTERGEAR

REVERSIBLE

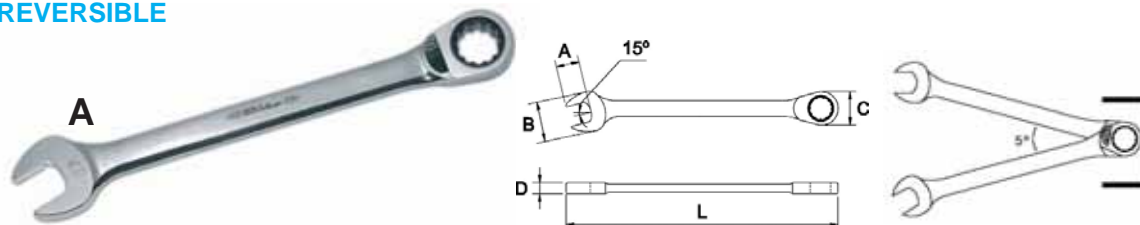

| COD | mm | L | A | B | C | D | mm | mm | mm |
|-------|--------|-----|------|------|------|-----|-----|----|----|
| 62680 | 8mm | 144 | 9,5 | 17 | 18 | 4,7 | 50 | 10 | 1 |
| 62681 | 9mm | 150 | 10 | 18,8 | 19,5 | 5,3 | 55 | | |
| 62682 | 10mm | 158 | 11 | 21,7 | 21 | 5,7 | 60 | | |
| 62683 | 11mm | 165 | 12,5 | 23 | 22 | 6,1 | 80 | | |
| 62684 | 12mm | 173 | 13,5 | 25,2 | 23,5 | 6,4 | 87 | | |
| 62685 | 13mm | 182 | 15 | 26,5 | 25 | 6,6 | 100 | | |
| 62686 | 14mm | 190 | 16 | 29,5 | 26,5 | 7,3 | 120 | | |
| 62687 | 15mm | 202 | 17 | 31,3 | 28 | 7,5 | 130 | | |
| 62688 | 16mm | 215 | 18 | 33,4 | 29 | 7,7 | 150 | | |
| 62689 | 17mm | 229 | 19,7 | 36,3 | 30,5 | 7,9 | 180 | | |
| 62690 | 18mm | 240 | 20,8 | 38 | 32 | 8,4 | 204 | | |
| 62691 | 19mm | 252 | 21,1 | 39 | 34 | 8,7 | 240 | | |
| 62692 | 21mm | 275 | 23,6 | 43,5 | 38 | 9,5 | 310 | | |
| 62693 | 22mm | 285 | 25 | 46,5 | 41 | 10 | 340 | | |
| 62694 | 24mm | 296 | 25,7 | 48,5 | 45 | 11 | 450 | | |
| 62695 | 5/16" | 144 | 9 | 17 | 18 | 4,7 | 50 | 10 | 1 |
| 62696 | 3/8" | 158 | 11,7 | 21,7 | 21 | 5,7 | 60 | | |
| 62697 | 7/16" | 165 | 12 | 23 | 22 | 6,1 | 80 | | |
| 62698 | 1/2" | 182 | 14,1 | 26,5 | 25 | 6,6 | 100 | | |
| 62699 | 9/16" | 190 | 16,5 | 29,5 | 26,5 | 7,3 | 120 | | |
| 62700 | 5/8" | 215 | 17,6 | 33,4 | 29 | 7,7 | 150 | | |
| 62701 | 11/16" | 229 | 20 | 36,3 | 30,5 | 7,9 | 180 | | |
| 62702 | 3/4" | 252 | 22 | 39 | 34 | 8,7 | 240 | | |
| 62703 | 13/16" | 275 | 22,7 | 43,5 | 38 | 9,5 | 310 | | |
| 62704 | 7/8" | 285 | 26 | 46,5 | 41 | 10 | 340 | | |
| 62705 | 15/16" | 296 | 26,6 | 48,5 | 45 | 11 | 450 | | |

Cr-V DIN 1711

SETS

| COD | Nº | 8-10-12-13-17-19 | 1/4"-10mm 3/8"-17mm 1/2"-19mm | 1/4"-1/4" | 1000 |
|-------|----|------------------|-------------------------------------|-----------|------|
| 69866 | 10 | 8-10-12-13-17-19 | 1/4"-10mm 3/8"-17mm 1/2"-19mm | 1/4"-1/4" | 1000 |
| 69867 | 6 | 8-10-12-13-17-19 | - | - | 800 |

| COD | Nº | 8-9-10-11-12-13-14-15-16-17-18-19 | 1/4"-10mm 3/8"-17mm 1/2"-19mm | 1/4"-1/4" | 2000 |
|-------|----|-----------------------------------|-------------------------------------|-----------|------|
| 69870 | 16 | 8-9-10-11-12-13-14-15-16-17-18-19 | 1/4"-10mm 3/8"-17mm 1/2"-19mm | 1/4"-1/4" | 2000 |
| 69871 | 12 | 8-9-10-11-12-13-14-15-16-17-18-19 | - | - | 1800 |



MASTERGEAR

LLAVE COMBINADA DE CARRACA MASTERGEAR / MASTERGEAR COMBINATION RATCHET WRENCH
 CLE MIXTE A CLIQUET MASTERGEAR / RATSCHEN-RINGGABELSCHLÜSSEL / CHIAVE COMBINATA A CRICCO MASTERGEAR
 RATELRINGSLEUTEL / CHAVE DE BOCA E LUNETA COM ROQUETE MASTERGEAR

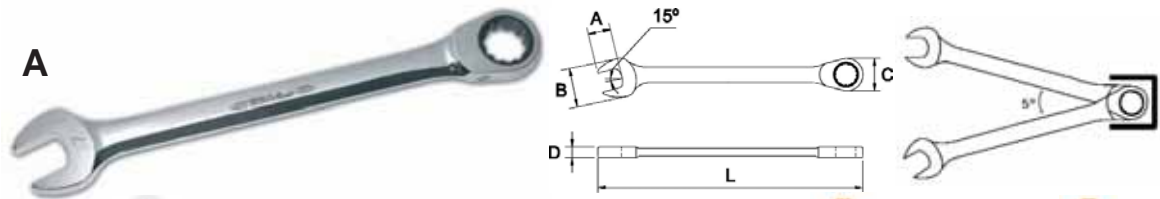

| COD | mm | L (mm) | A | B | C | D | mm | mm | mm |
|-------|--------|--------|------|------|------|-----|-----|----|----|
| 62651 | 8mm | 144 | 9,5 | 17 | 18 | 4,7 | 50 | 10 | 1 |
| 62652 | 9mm | 150 | 10 | 18,8 | 19,5 | 5,3 | 55 | | |
| 62653 | 10mm | 158 | 11 | 21,7 | 21 | 5,7 | 60 | | |
| 62654 | 11mm | 165 | 12,5 | 23 | 22 | 6,1 | 80 | | |
| 62655 | 12mm | 173 | 13,5 | 25,2 | 23,5 | 6,4 | 87 | | |
| 62656 | 13mm | 182 | 15 | 26,5 | 25 | 6,6 | 100 | | |
| 62657 | 14mm | 190 | 16 | 29,5 | 26,5 | 7,3 | 120 | | |
| 62658 | 15mm | 202 | 17 | 31,3 | 28 | 7,5 | 130 | | |
| 62659 | 16mm | 215 | 18 | 33,4 | 29 | 7,7 | 150 | | |
| 62660 | 17mm | 229 | 19,7 | 36,3 | 30,5 | 7,9 | 180 | | |
| 62661 | 18mm | 240 | 20,8 | 38 | 32 | 8,4 | 204 | | |
| 62662 | 19mm | 252 | 21,1 | 39 | 34 | 8,7 | 240 | | |
| 62663 | 21mm | 275 | 23,6 | 43,5 | 38 | 9,5 | 310 | | |
| 62664 | 22mm | 285 | 25 | 46,5 | 41 | 10 | 340 | | |
| 62665 | 24mm | 296 | 25,7 | 48,5 | 45 | 11 | 450 | | |
| 62666 | 5/16" | 144 | 9 | 17 | 18 | 4,7 | 50 | 10 | 1 |
| 62667 | 3/8" | 158 | 11,7 | 21,7 | 21 | 5,7 | 60 | | |
| 62668 | 7/16" | 165 | 12 | 23 | 22 | 6,1 | 80 | | |
| 62669 | 1/2" | 182 | 14,1 | 26,5 | 25 | 6,6 | 100 | | |
| 62670 | 9/16" | 190 | 16,5 | 29,5 | 26,5 | 7,3 | 120 | | |
| 62671 | 5/8" | 215 | 17,6 | 33,4 | 29 | 7,7 | 150 | | |
| 62672 | 11/16" | 229 | 20 | 36,3 | 30,5 | 7,9 | 180 | | |
| 62673 | 3/4" | 252 | 22 | 39 | 34 | 8,7 | 240 | | |
| 62674 | 13/16" | 275 | 22,7 | 43,5 | 38 | 9,5 | 310 | | |
| 62675 | 7/8" | 285 | 26 | 46,5 | 41 | 10 | 340 | | |
| 62676 | 15/16" | 296 | 26,6 | 48,5 | 45 | 11 | 450 | | |

Cr-V DIN 1711

SETS

| COD | Nº | Wrenches | Bits | Accessories | Price |
|-------|----|------------------|-------------------------------------|-------------|-------|
| 69864 | 10 | 8-10-12-13-17-19 | 1/4"-10mm 3/8"-17mm 1/2"-19mm | 1/4"-1/4" | 1000 |
| 69865 | 6 | 8-10-12-13-17-19 | - | - | 800 |

| COD | Nº | Wrenches | Bits | Accessories | Price |
|-------|----|--------------------------------------|-------------------------------------|-------------|-------|
| 69868 | 16 | 8-9-10-11-12-13 14-15-16-17-18-19 | 1/4"-10mm 3/8"-17mm 1/2"-19mm | 1/4"-1/4" | 2000 |
| 69869 | 12 | 8-9-10-11-12-13 14-15-16-17-18-19 | - | - | 1800 |

DEMO-BLOCK

| COD | mm | Accessories | Price |
|-------|------|-----------------------|-------|
| 64502 | 13mm | 6 different bit types | 300 |



MASTERGEAR ARTICULADA / MASTERGEAR JOINT / MASTERGEAR ARTICULÉE / FLEXIBLE MASTERGEAR / MASTERGEAR SNODATA / FLEXIBELE MASTERGEAR / MASTERGEAR ARTICULADA

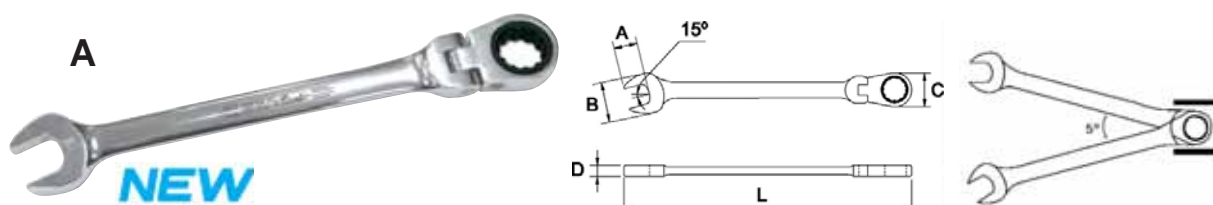

| COD | mm | L | A | B | C | D | mm | mm | mm |
|-------|--------|-----|------|------|------|-----|-----|----|----|
| 61530 | 8mm | 145 | 9,5 | 17 | 18 | 4,7 | 60 | 10 | 1 |
| 61531 | 9mm | 150 | 10 | 18,8 | 19,5 | 5,3 | 65 | | |
| 61532 | 10mm | 157 | 11 | 21,7 | 21 | 5,7 | 70 | | |
| 61533 | 11mm | 165 | 12,5 | 23 | 22 | 6,1 | 90 | | |
| 61534 | 12mm | 172 | 13,5 | 25,2 | 23,5 | 6,4 | 97 | | |
| 61535 | 13mm | 182 | 15 | 26,5 | 25 | 6,6 | 110 | | |
| 61536 | 14mm | 190 | 16 | 29,5 | 26,5 | 7,3 | 120 | | |
| 61537 | 15mm | 201 | 17 | 31,3 | 28 | 7,5 | 140 | | |
| 61538 | 16mm | 215 | 18 | 33,4 | 29 | 7,7 | 160 | | |
| 61539 | 17mm | 229 | 19,7 | 36,3 | 30,5 | 7,9 | 190 | | |
| 61540 | 18mm | 240 | 20,8 | 38 | 32 | 8,4 | 214 | | |
| 61541 | 19mm | 251 | 21,1 | 39 | 34 | 8,7 | 240 | | |
| 61542 | 20mm | 274 | 23,6 | 43,5 | 38 | 9,5 | 250 | | |
| 61543 | 22mm | 284 | 25 | 46,5 | 41 | 10 | 350 | | |
| 61544 | 24mm | 296 | 25,7 | 48,5 | 45 | 11 | 460 | | |
| 61545 | 5/16" | 145 | 9 | 17 | 18 | 4,7 | 60 | 10 | 1 |
| 61546 | 3/8" | 157 | 11,7 | 21,7 | 21 | 5,7 | 70 | | |
| 61547 | 7/16" | 165 | 12 | 23 | 22 | 6,1 | 90 | | |
| 61548 | 1/2" | 182 | 14,1 | 26,5 | 25 | 6,6 | 110 | | |
| 61549 | 9/16" | 190 | 16,5 | 29,5 | 26,5 | 7,3 | 130 | | |
| 61550 | 5/8" | 215 | 17,6 | 33,4 | 29 | 7,7 | 170 | | |
| 61551 | 11/16" | 229 | 20 | 36,3 | 30,5 | 7,9 | 190 | | |
| 61552 | 3/4" | 251 | 22 | 39 | 34 | 8,7 | 250 | | |
| 61553 | 13/16" | 274 | 22,7 | 43,5 | 38 | 9,5 | 320 | | |
| 61554 | 7/8" | 284 | 26 | 46,5 | 41 | 10 | 350 | | |
| 61555 | 15/16" | 296 | 26,6 | 48,5 | 45 | 11 | 460 | | |

Cr-V DIN 1711

SETS

| COD | UN. | |
|-------|-----|--------------------------------|
| 69105 | 6 | 8-10-12-13-17-19 mm |
| 69106 | 8 | 8-10-12-13-14-17-19-22 mm |
| 69107 | 10 | 8-9-10-11-12-13-14-17-19-22 mm |

| COD | UN. | |
|-------|-----|--|
| 69101 | 6 | 3/8, 7/16, 1/2, 9/16, 5/8, 3/4 |
| 69102 | 8 | 5/16, 3/8, 7/16, 1/2, 9/16, 5/8, 11/16, 3/4 |
| 69103 | 10 | 3/8, 7/16, 1/2, 9/16, 5/8, 11/16, 3/4, 13/16, 7/8, 15/16 |



NEW

MASTERGEAR STUBBY

LLAVE COMBINADA DE CARRACA SERIE CORTA / STUBBY MASTERGEAR COMBINATION RATCHET WRENCH
 CLE MIXTE A CLIQUET COURTE MASTERGEAR / RATSCHEN-RINGGABELSCHLÜSSEL KURZ / RATELRINGSLEUTEL KORT
 CHIAVE COMBINATA A CRICCO SERIE CORTA MASTERGEAR / CHAVE DE BOCA E LUNETA ROQUETE SERIE CURTA MASTERGEAR

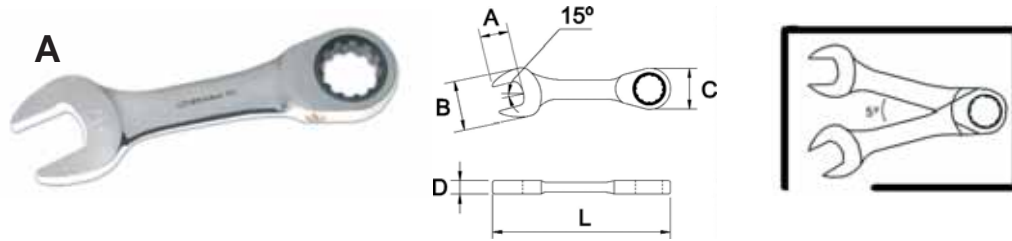

| COD | mm | L | A | B | C | D | mm | mm | mm |
|-------|--------|-----|------|------|------|-----|-----|----|----|
| 62710 | 8mm | 89 | 9,5 | 17 | 17 | 4,7 | 29 | 10 | 1 |
| 62711 | 9mm | 93 | 10 | 19,5 | 18,8 | 5,3 | 36 | | |
| 62712 | 10mm | 98 | 11 | 21 | 21,7 | 5,7 | 44 | | |
| 62713 | 11mm | 103 | 12,5 | 22 | 22,9 | 6,1 | 58 | | |
| 62714 | 12mm | 103 | 13,5 | 23,5 | 25,2 | 6,4 | 58 | | |
| 62715 | 13mm | 110 | 15 | 25 | 26,5 | 6,6 | 68 | | |
| 62716 | 14mm | 115 | 16 | 26,5 | 29,6 | 7,3 | 80 | | |
| 62717 | 15mm | 119 | 17 | 28 | 31,3 | 7,5 | 90 | | |
| 62718 | 16mm | 122 | 18 | 29,5 | 33,4 | 7,7 | 105 | | |
| 62719 | 17mm | 127 | 19,7 | 30,5 | 36,3 | 7,9 | 118 | | |
| 62720 | 18mm | 131 | 20,8 | 32 | 38 | 8,4 | 142 | | |
| 62721 | 19mm | 136 | 21,1 | 34 | 39 | 8,7 | 160 | | |
| <hr/> | | | | | | | | | |
| 62722 | 5/16" | 89 | 9 | 17 | 17 | 4,7 | 29 | 10 | 1 |
| 62723 | 3/8" | 98 | 11,7 | 21 | 21,7 | 5,7 | 44 | | |
| 62724 | 7/16" | 103 | 12 | 22 | 22,9 | 6,1 | 58 | | |
| 62725 | 1/2" | 110 | 14,1 | 25 | 26,5 | 6,6 | 68 | | |
| 62726 | 9/16" | 115 | 16,5 | 26,5 | 29,6 | 7,3 | 80 | | |
| 62727 | 5/8" | 122 | 17,5 | 29,5 | 33,4 | 7,7 | 105 | | |
| 62728 | 11/16" | 127 | 20 | 30,5 | 36,3 | 7,9 | 118 | | |
| 62729 | 3/4" | 136 | 22 | 34 | 39 | 8,7 | 160 | | |

Cr-V DIN 1711

SET

| COD | Nº | mm | mm | mm | mm | mm |
|-------|----|-------------------------------|-------------------------------------|-----------|------|----|
| 69872 | 14 | 10-11-12-13-14-15-16-17-18-19 | 1/4"-10mm 3/8"-17mm 1/2"-19mm | 1/4"-1/4" | 1300 | |
| 69873 | 10 | 10-11-12-13-14-15-16-17-18-19 | - | - | 1100 | |



ADAPTADOR / ADAPTER / ADAPTATEUR / VERBINDUNGSTEILE / ADATTATORE / ADAPTOR / ADAPTADOR

| COD | mm | mm | mm | mm | mm | mm |
|-------|-----------|-----------|----|----|----|----|
| 62772 | 1/4"-10mm | - | 20 | 12 | 6 | - |
| 62773 | 3/8"-17mm | - | 28 | 39 | | |
| 62774 | 1/2"-19mm | - | 35 | 65 | | |
| 62775 | - | 1/4"-1/4" | 25 | 10 | | |



MASTERGEAR E-TORX

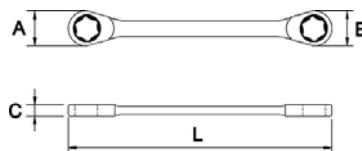

| COD | Hex Size | L | A | B | C | Weight | Quantity | Material |
|-------|-----------|-----|------|------|-----|--------|----------|----------|
| 62734 | E6 x E8 | 120 | 18 | 18 | 7,7 | 49 | 10 | 1 |
| 62735 | E10 x E12 | 137 | 18 | 19,5 | 7 | 61 | | |
| 62736 | E14 x E16 | 178 | 22 | 25 | 7,4 | 105 | | |
| 62737 | E18 x E20 | 200 | 26,5 | 29 | 8,7 | 145 | | |
| 62738 | E22 x E24 | 223 | 30,5 | 34,5 | 10 | 216 | | |

Cr-V DIN 1711

SET

| COD | Nº | Contents | Weight |
|-------|----|--|--------|
| 69874 | 5 | E6 x E8 - E10 x E12 - E14 x E16 E18 x E20 - E22 x E24 | 950 |



RAPID WRENCH

LLAVE COMBINADA RAPIDA / RAPID COMBINATION WRENCH / CLE MIXTE RAPIDE / RINGGABELSCHLÜSSEL RAPID
CHIAVE COMBINATA RAPIDA / STEEKRINGSLEUTEL RAPID / CHAVE BOCA E LUNETA DE RETOMA RAPIDA

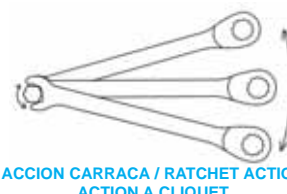
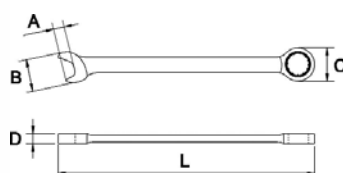

ACCION CARRACA / RATCHET ACTION
ACTION A CLIQUET

| COD | Size | L | A | B | C | D | Weight | Quantity | Material |
|-------|--------|-----|------|------|------|------|--------|----------|----------|
| 62740 | 8mm | 144 | 6,3 | 14,7 | 13,5 | 4,8 | 30 | 10 | 1 |
| 62742 | 10mm | 163 | 7,8 | 18,3 | 16 | 5 | 50 | | |
| 62743 | 11mm | 168 | 9,5 | 20,4 | 18 | 5,8 | 60 | | |
| 62744 | 12mm | 175 | 10,1 | 22 | 19 | 6,8 | 66 | | |
| 62745 | 13mm | 180 | 10,9 | 23,8 | 21 | 7 | 73 | | |
| 62746 | 14mm | 195 | 11,8 | 26,2 | 22 | 8 | 93 | | |
| 62747 | 15mm | 200 | 12,1 | 27,5 | 23 | 8,5 | 100 | | |
| 62748 | 16mm | 210 | 12,3 | 29,5 | 25 | 9,5 | 128 | | |
| 62749 | 17mm | 230 | 14,1 | 31,1 | 26 | 10 | 154 | | |
| 62750 | 18mm | 240 | 15,9 | 33 | 28 | 11,5 | 168 | | |
| 62751 | 19mm | 252 | 16,1 | 34,9 | 29 | 11,5 | 195 | | |
| 62752 | 20mm | 262 | 16,2 | 38,4 | 31 | 11,5 | 300 | | |
| 62753 | 21mm | 273 | 16,7 | 40,3 | 32 | 11,5 | 300 | | |
| 62754 | 22mm | 284 | 17,3 | 42,2 | 34 | 11,5 | 310 | | |
| 62755 | 23mm | 295 | 18,6 | 44,1 | 35 | 11,5 | 380 | | |
| 62756 | 24mm | 306 | 19,5 | 46 | 36 | 11,5 | 420 | | |
| 62757 | 26mm | 328 | 20,6 | 49,8 | 39 | 11,5 | 500 | | |
| 62758 | 5/16" | 144 | 6,3 | 14,7 | 13,5 | 4,8 | 30 | 10 | 1 |
| 62759 | 3/8" | 163 | 7,8 | 18,3 | 16 | 5 | 50 | | |
| 62760 | 7/16" | 168 | 9,5 | 20,4 | 18 | 5,8 | 60 | | |
| 62761 | 1/2" | 180 | 10,9 | 23,8 | 21 | 6,8 | 73 | | |
| 62762 | 9/16" | 195 | 11,8 | 26,2 | 22 | 7 | 93 | | |
| 62763 | 5/8" | 210 | 12,3 | 29,3 | 25 | 8 | 128 | | |
| 62764 | 11/16" | 230 | 14,1 | 31,1 | 26 | 8,5 | 154 | | |
| 62765 | 3/4" | 252 | 16,1 | 34,9 | 29 | 9,5 | 195 | | |
| 62766 | 13/16" | 273 | 16,7 | 40,3 | 32 | 10 | 300 | | |
| 62767 | 7/8" | 284 | 17,3 | 42,2 | 34 | 11 | 310 | | |
| 62768 | 15/16" | 306 | 19,5 | 46 | 36 | 11,5 | 420 | | |
| 62769 | 1" | 328 | 20,6 | 49,8 | 39 | 11,5 | 500 | | |



LLAVES / WRENCHES / CLES / SCHLÜSSEL / CHIAVI / SLEUTELS / CHAVES

LLAVES FIJAS / OPEN-END WRENCHES / CLES PLATES / GABELSCHLÜSSEL / CHIAVI FISSE / STEEKSLEUTELS
 CHAVES DUAS BOCAS

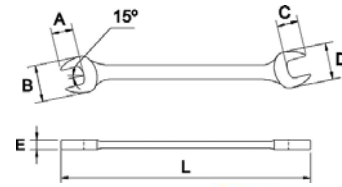

| A | COD | B | L | | | | | | | 15° | | E | |
|-------|-------|---------|-----|------|------|------|------|------|-----|-----|---|---|--|
| A | COD | B | L | A | B | C | D | E | 15° | | E | | |
| 61601 | 61701 | 6-7mm | 122 | 9 | 16 | 9 | 17,5 | 4,6 | 22 | 10 | 1 | | |
| 61602 | 61702 | 8-9mm | 141 | 9,3 | 19 | 10,5 | 20,7 | 5,5 | 38 | | | | |
| 61603 | 61703 | 10-11mm | 155 | 11 | 21 | 9,7 | 24 | 5,5 | 52 | | | | |
| 61604 | 61704 | 12-13mm | 167 | 11,4 | 28 | 10,7 | 30,4 | 5,5 | 70 | | | | |
| 61605 | 61705 | 14-15mm | 184 | 13,9 | 30,7 | 14,3 | 33 | 7 | 115 | | | | |
| 61606 | 61706 | 16-17mm | 202 | 14,2 | 35,1 | 16,3 | 37,2 | 7 | 130 | | | | |
| 61614 | 61700 | 17-19mm | 213 | 17 | 39 | 18,1 | 41,1 | 7,6 | 165 | | | | |
| 61607 | 61707 | 18-19mm | 222 | 17,6 | 39,3 | 18,5 | 41,8 | 7,7 | 160 | | | | |
| 61608 | 61708 | 20-22mm | 233 | 19 | 43,4 | 22 | 47,4 | 7,8 | 205 | | | | |
| 61609 | 61709 | 21-23mm | 243 | 23 | 47,5 | 22,8 | 51,2 | 9,1 | 250 | | | | |
| 61610 | 61710 | 24-26mm | 265 | 27,5 | 52,1 | 30,2 | 55,6 | 9,1 | 332 | 5 | 1 | | |
| 61651 | 61652 | 24-27mm | 268 | 27,5 | 52,1 | 30,3 | 55,7 | 9,1 | 335 | | | | |
| 61611 | 61711 | 25-28mm | 269 | 29,8 | 52,5 | 30,4 | 55,8 | 9,1 | 420 | | | | |
| 61612 | 61712 | 27-29mm | 282 | 29,8 | 64,5 | 34,5 | 69 | 10 | 430 | | | | |
| 61613 | 61713 | 30-32mm | 310 | 33,8 | 60 | 35,3 | 66,2 | 10,5 | 500 | | | | |

Cr-V DIN 3110

LLAVES COMBINADAS / COMBINATION WRENCHES / CLES MIXTES / RINGGABELSCHLÜSSEL / CHIAVI COMBINATE
 RINGSTEEKSLEUTELS / CHAVES BOCA E LUNETA

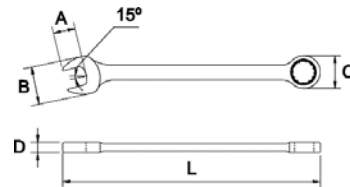

| A | COD | B | L | | | | | | | 15° | | E | |
|-------|-------|------|--------|------|-------|------|------|------|-----|-----|---|---|--|
| A | COD | B | L | A | B | C | D | E | 15° | | E | | |
| 61625 | 61725 | 6mm | 100,8 | 7,1 | 15,9 | 11,8 | 3,3 | 16 | 10 | 1 | | | |
| 61626 | 61726 | 7mm | 110,9 | 7,2 | 16,44 | 12,2 | 3,6 | 20 | | | | | |
| 61627 | 61727 | 8mm | 121,72 | 10,2 | 17,6 | 13,4 | 4,8 | 25 | | | | | |
| 61628 | 61728 | 9mm | 131,2 | 10,7 | 18,8 | 15,5 | 5,4 | 30 | | | | | |
| 61629 | 61729 | 10mm | 140,5 | 11,5 | 21,2 | 17,2 | 5,5 | 38 | | | | | |
| 61630 | 61730 | 11mm | 158 | 12,2 | 23,3 | 18,1 | 5,6 | 45 | | | | | |
| 61631 | 61731 | 12mm | 160,1 | 14,5 | 24,6 | 18,8 | 6,3 | 52 | | | | | |
| 61632 | 61732 | 13mm | 161,7 | 15,1 | 27,2 | 20,3 | 6,5 | 70 | | | | | |
| 61633 | 61733 | 14mm | 180,8 | 15,6 | 29,3 | 21,5 | 6,6 | 75 | | | | | |
| 61634 | 61734 | 15mm | 190,6 | 16,3 | 31,6 | 22,7 | 6,7 | 90 | | | | | |
| 61635 | 61735 | 16mm | 200,1 | 16,5 | 33,1 | 24,2 | 6,7 | 92 | | | | | |
| 61636 | 61736 | 17mm | 208 | 18,5 | 35,5 | 26,1 | 7,5 | 110 | | | | | |
| 61637 | 61737 | 18mm | 211 | 20,6 | 38,1 | 26,4 | 7,8 | 135 | | | | | |
| 61638 | 61738 | 19mm | 228 | 21,2 | 39,4 | 29,5 | 7,9 | 162 | | | | | |
| 61639 | 61739 | 20mm | 240 | 23,1 | 41,3 | 30,2 | 7,9 | 180 | | | | | |
| 61640 | 61740 | 21mm | 247 | 23,8 | 45,6 | 31,3 | 7,9 | 210 | | | | | |
| 61641 | 61741 | 22mm | 256 | 24,7 | 48,4 | 32,7 | 7,9 | 222 | | | | | |
| 61642 | 61742 | 23mm | 265 | 25,7 | 48,5 | 34,8 | 7,9 | 260 | | | | | |
| 61643 | 61743 | 24mm | 280 | 25,9 | 48,7 | 35,6 | 7,9 | 285 | | | | | |
| 61644 | 61744 | 25mm | 296 | 29,1 | 50,2 | 36,5 | 9,1 | 295 | | | | | |
| 61645 | 61745 | 26mm | 297 | 29,5 | 53,9 | 36,7 | 9,1 | 365 | | | | | |
| 61646 | 61746 | 27mm | 330 | 31,6 | 54,5 | 40,9 | 10,3 | 425 | | | | | |
| 61647 | 61747 | 28mm | 340 | 32,1 | 56,7 | 41,6 | 10,6 | 450 | | | | | |
| 61648 | 61748 | 29mm | 342 | 32,3 | 63,5 | 41,7 | 10,6 | 515 | | | | | |
| 61649 | 61749 | 30mm | 345 | 33,5 | 64,1 | 43,5 | 10,6 | 560 | | | | | |
| 61650 | 61750 | 32mm | 354 | 34,2 | 65,1 | 46,9 | 10,6 | 625 | | | | | |
| - | 60951 | 34mm | 386 | 34,4 | 68,4 | 49,5 | 11,2 | 630 | | | | | |
| - | 60952 | 36mm | 418 | 35,9 | 73,1 | 53,9 | 13,6 | 787 | | | | | |
| - | 60953 | 38mm | 419 | 36,3 | 73,1 | 54,1 | 13,6 | 820 | | | | | |
| - | 60954 | 41mm | 466 | 40,8 | 83,6 | 61,7 | 16,7 | 1260 | | | | | |
| - | 60955 | 46mm | 550 | 46,2 | 90,6 | 64,4 | 18,8 | 1750 | | | | | |
| - | 60956 | 50mm | 550 | 50 | 100,1 | 72,1 | 19,3 | 2035 | | | | | |

Cr-V DIN 3113

LLAVES ACODADAS / DOUBLE OFFSET RING WRENCHES / CLES POLYGONALES / RINGSCHLÜSSEL / CHIAVI POLIGONALI / RINGSLEUTELS / CHAVES LUNETA

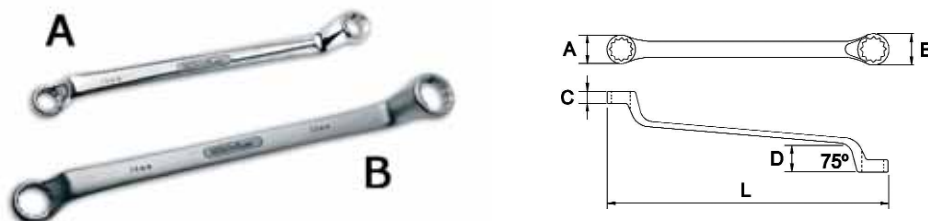

| A | COD | B | L | A | B | C | D | | |
|-------|-------|---------|-----|------|------|------|------|------|----|
| 61675 | 61775 | 6-7mm | 171 | 10,9 | 11,8 | 6,3 | 18,6 | 50 | 10 |
| 61676 | 61776 | 8-9mm | 180 | 14,9 | 16,6 | 6,7 | 19,8 | 65 | |
| 61677 | 61777 | 10-11mm | 198 | 17,4 | 18,9 | 7,7 | 21,8 | 85 | |
| 61678 | 61778 | 12-13mm | 220 | 19,5 | 21 | 8,9 | 23,5 | 110 | |
| 61679 | 61779 | 14-15mm | 238 | 22,4 | 23,6 | 9,5 | 24,8 | 140 | |
| 61680 | 61780 | 16-17mm | 265 | 25,4 | 27 | 9,5 | 27,5 | 180 | |
| 61681 | 61781 | 18-19mm | 286 | 27,8 | 29,5 | 12,5 | 27,5 | 225 | |
| 61682 | 61782 | 20-22mm | 323 | 31,7 | 34,1 | 12,8 | 28,9 | 360 | |
| 61683 | 61783 | 21-23mm | 327 | 35,3 | 38,7 | 12,8 | 30,3 | 400 | |
| 61684 | 61784 | 24-26mm | 338 | 36,5 | 41,3 | 12,8 | 30,4 | 490 | |
| - | 61788 | 24-27mm | 342 | 37,5 | 42,5 | 12,8 | 31,2 | 445 | 5 |
| 61685 | 61785 | 25-28mm | 348 | 38,6 | 43,1 | 12,8 | 31,8 | 580 | |
| 61686 | 61786 | 27-29mm | 350 | 38,8 | 41,5 | 13,1 | 31,9 | 620 | |
| 61687 | 61787 | 30-32mm | 373 | 44,5 | 47,2 | 16,1 | 32,8 | 695 | |
| 61690 | 61789 | 36-41mm | 540 | 69,1 | 74,9 | 19,4 | 48,9 | 1080 | |
| 61691 | 61790 | 46-50mm | 545 | 69,8 | 75,5 | 19,8 | 50,4 | 1970 | |

Cr-V DIN 838

LLAVES FIJAS / OPEN-END WRENCHES / CLES PLATES / GABELSCHLÜSSEL / CHIAVI FISSE / STEEKSLEUTELS / CHAVES DUAS BOCAS



| COD | A | L | A | B | C | D | E | | |
|-------|----------------|-----|------|------|------|------|-----|-----|----|
| 60300 | 1/4-5/16" | 122 | 8,1 | 14,5 | 8,9 | 16,9 | 3,6 | 22 | 10 |
| 60301 | 5/16-3/8" | 140 | 9,9 | 19,8 | 11,6 | 21,9 | 3,8 | 38 | |
| 60302 | 3/8-7/16" | 159 | 12,7 | 22,4 | 13,3 | 24,3 | 5,5 | 52 | |
| 60303 | 1/2-9/16" | 174 | 14,3 | 26,6 | 14,5 | 28,4 | 5,6 | 60 | |
| 60304 | 9/16-5/8" | 190 | 17,2 | 30,1 | 16,6 | 33,2 | 5,6 | 72 | |
| 60305 | 19/32-11/16" | 204 | 18,4 | 35,1 | 19,1 | 37,8 | 5,9 | 85 | |
| 60306 | 5/8-11/16" | 204 | 18,4 | 35,1 | 18,1 | 38 | 5,9 | 115 | |
| 60307 | 11/16-3/4" | 220 | 18,9 | 38,5 | 21,1 | 40,5 | 6,3 | 130 | |
| 60308 | 3/4-25/32" | 220 | 20,7 | 38,6 | 21,3 | 40,6 | 6,4 | 160 | |
| 60309 | 3/4-7/8" | 234 | 21,1 | 44,1 | 23,8 | 47,7 | 7,2 | 205 | |
| 60310 | 13/16-7/8" | 235 | 24,9 | 44,8 | 27,9 | 47,8 | 7,5 | 255 | 5 |
| 60311 | 15/16-1" | 262 | 26,1 | 51 | 28,4 | 57,2 | 7,9 | 332 | |
| 60312 | 1-1.1/8" | 278 | 26,3 | 54,1 | 30,2 | 59,1 | 8,3 | 420 | |
| 60313 | 1.1/16-1.1/18" | 278 | 28,1 | 54,3 | 31,1 | 59,8 | 8,4 | 430 | |
| 60314 | 1.1/16-1.1/4" | 318 | 34,6 | 60,1 | 36,5 | 65,9 | 9,7 | 510 | |

Cr-V DIN 3110

A cromado pulido espejo / mirror polished chrome plating / polie chromée / poliert verchromt / cromate lucide gepolijst en verchromd / cromado polido

B cromado aeroespacial / aerospaceal chrome plating / chromée aérospatiale / verchromt aerospaceal / cromate satiné / verchromd aerospaceal / cromado fosco aerospaceal

LLAVES / WRENCHES / CLES / SCHLÜSSEL / CHIAVI / SLEUTELS / CHAVES

LLAVES COMBINADAS / COMBINATION WRENCHES / CLES MIXTES / GABEL RINGGABELSCHLÜSSEL / CHIAVI COMBinate RINGSTEEKSLEUTELS / CHAVES BOCA E LUNETA

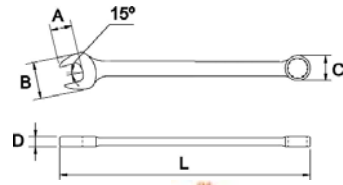

| COD | A | L | A | B | C | D | SP | 10 | 5 | 1 |
|-------|---------|-----|------|------|------|------|------|----|---|---|
| 60340 | 1/4" | 100 | 6,7 | 14,1 | 9,3 | 3,8 | 16 | | | |
| 60341 | 5/16" | 120 | 9,1 | 17,5 | 12,4 | 4,58 | 25 | | | |
| 60342 | 3/8" | 141 | 11,2 | 26,7 | 16,9 | 5,4 | 38 | | | |
| 60343 | 7/16" | 171 | 14,7 | 26,8 | 20,1 | 6,2 | 45 | | | |
| 60344 | 1/2" | 181 | 15,9 | 29,4 | 21,5 | 6,7 | 70 | | | |
| 60345 | 9/16" | 181 | 16,1 | 29,5 | 21,8 | 7,2 | 75 | | | |
| 60346 | 19/32" | 191 | 16,4 | 31,7 | 23,2 | 7,3 | 90 | | | |
| 60347 | 5/8" | 200 | 17,6 | 32,8 | 25,1 | 7,4 | 92 | | | |
| 60348 | 11/16" | 217 | 19,1 | 37,3 | 28,1 | 7,8 | 130 | | | |
| 60349 | 3/4" | 218 | 20,5 | 37,4 | 28,3 | 7,9 | 162 | | | |
| 60350 | 25/32" | 240 | 22,7 | 41,4 | 31,3 | 8,2 | 180 | | | |
| 60351 | 13/16" | 248 | 23,3 | 43,1 | 32,4 | 8,5 | 210 | | | |
| 60352 | 7/8" | 276 | 24,6 | 48,9 | 35,6 | 8,5 | 222 | | | |
| 60353 | 15/16" | 286 | 26,1 | 50,8 | 36,8 | 8,7 | 285 | | | |
| 60354 | 1" | 295 | 27,8 | 52,7 | 38,1 | 8,8 | 300 | | | |
| 60355 | 1.1/16" | 307 | 29,3 | 54,6 | 39,3 | 9,1 | 425 | | | |
| 60356 | 1.1/8" | 357 | 33,2 | 58,1 | 42,1 | 10,5 | 450 | | | |
| 60357 | 1.3/16" | 364 | 33,7 | 59,3 | 43,6 | 11,1 | 495 | | | |
| 60358 | 1.1/4" | 385 | 34,1 | 60,6 | 45,5 | 11,1 | 580 | | | |
| 60957 | 1.5/16" | 385 | 34,5 | 67,6 | 48,9 | 11,2 | 580 | | | |
| 60958 | 1.3/8" | 385 | 34,8 | 68,2 | 49,1 | 11,2 | 787 | | | |
| 60959 | 1.1/2" | 438 | 37,7 | 75,2 | 56,1 | 16,3 | 787 | | | |
| 60960 | 2" | 544 | 49,2 | 99,4 | 71,2 | 19,2 | 2035 | | | |

Cr-V DIN 3113

LLAVES ACODADAS / DOUBLE OFFSET RING WRENCHES / CLES POLYGOALES / RINGSCHLÜSSEL / CHIAVI POLIGONALI RINGSLEUTELS / CHAVES LUNETA

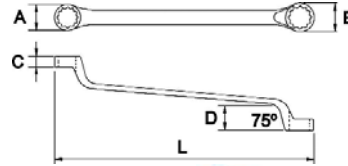

| COD | A | L | A | B | C | D | SP | 10 | 5 | 1 |
|-------|----------------|-----|------|------|------|------|-----|----|---|---|
| 60380 | 1/4-5/16" | 170 | 10,3 | 12 | 5,4 | 18,7 | 50 | | | |
| 60381 | 5/16-3/8" | 185 | 12,9 | 14,3 | 5,7 | 20,3 | 65 | | | |
| 60382 | 3/8-7/16" | 198 | 14,8 | 16,1 | 7,1 | 22,1 | 85 | | | |
| 60383 | 1/2-9/16" | 238 | 21,3 | 23,5 | 9,1 | 24,9 | 100 | | | |
| 60384 | 9/16-5/8" | 241 | 20,7 | 23,6 | 9,3 | 26,5 | 125 | | | |
| 60385 | 19/32-11/16" | 265 | 24,6 | 25,1 | 10,2 | 27,9 | 130 | | | |
| 60386 | 5/8-11/16" | 289 | 26,1 | 27,8 | 10,5 | 30,3 | 140 | | | |
| 60387 | 11/16-3/4" | 290 | 26,2 | 27,9 | 10,5 | 30,5 | 180 | | | |
| 60388 | 3/4-25/32" | 291 | 26,3 | 27,9 | 10,6 | 30,7 | 245 | | | |
| 60389 | 3/4-7/8" | 294 | 26,9 | 30,1 | 10,7 | 31,2 | 360 | | | |
| 60390 | 13/16-7/8" | 319 | 30,4 | 32,5 | 10,8 | 31,5 | 400 | | | |
| 60391 | 15/16-1" | 321 | 30,5 | 32,6 | 11,1 | 31,6 | 470 | | | |
| 60392 | 1-1.1/8" | 354 | 43,9 | 48,1 | 15,2 | 35,3 | 580 | | | |
| 60393 | 1.1/16-1.1/18" | 357 | 44,3 | 48,1 | 15,4 | 35,7 | 620 | | | |
| 60394 | 1.1/16-1.1/4" | 361 | 44,6 | 48,2 | 15,7 | 36,2 | 650 | | | |

Cr-V DIN 838

KIT DEMO 6 LLAVES / 6 SPANNER DEMO KIT / KIT DÉMO. 6 CLÉS / DEMOKIT 6 SCHLÜSSEL / KIT 6 CHIAVI DI DIMOSTRAZIONE / DEMOKIT 6 SLEUTELS / KIT DEMO 6 CHAVES

| COD | Composicion/Composition | 8mm | 300 |
|-------|-------------------------|----------------------|-----|
| 69342 | 61727 | Cr-V Aeroespacial | |
| | 61627 | Cr-V Espejo - Mirror | |
| | 73062 | Cr-V 1000V | |
| | 70172 | Cu-Be | |
| | 70684 | Al-Bron | |
| | 71669 | Titanium | |

NEW



SETS

LLAVES FIJAS / OPEN-END WRENCHES / CLES PLATES / GABELSCHLÜSSEL / CHIAVI FISSE / STEEKSLEUTELS / CHAVES DUAS BOCAS

| COD | UN. | A |
|-------|-----|--|
| 69244 | 6 | 6-7, 8-9, 10-11, 12-13, 14-15, 16-17 |
| 69245 | 8 | 6-7, 8-9, 10-11, 12-13, 14-15, 16-17, 18-19, 20-22 |
| 69246 | 10 | 6-7, 8-9, 10-11, 12-13, 14-15, 16-17, 18-19, 20-22, 21-23, 24-26 |
| 69247 | 12 | 6-7, 8-9, 10-11, 12-13, 14-15, 16-17, 18-19, 20-22, 21-23, 24-26, 25-28, 30-32 |
| 69794 | 12 | 6-7, 8-9, 10-11, 12-13, 14-15, 16-17, 18-19, 20-22, 21-23, 24-27, 25-28, 30-32 |



| COD | UN. | B |
|-------|-----|--|
| 69248 | 6 | 6-7, 8-9, 10-11, 12-13, 14-15, 16-17 |
| 69249 | 8 | 6-7, 8-9, 10-11, 12-13, 14-15, 16-17, 18-19, 20-22 |
| 69250 | 10 | 6-7, 8-9, 10-11, 12-13, 14-15, 16-17, 18-19, 20-22, 21-23, 24-26 |
| 69251 | 12 | 6-7, 8-9, 10-11, 12-13, 14-15, 16-17, 18-19, 20-22, 21-23, 24-26, 25-28, 30-32 |
| 69795 | 12 | 6-7, 8-9, 10-11, 12-13, 14-15, 16-17, 18-19, 20-22, 21-23, 24-27, 25-28, 30-32 |

LLAVES COMBINADAS / COMBINATION WRENCHES / CLES MIXTES / GABELRINGSCHLÜSSEL / CHIAVI COMBinate RINGSTEEKSLEUTELS / CHAVES BOCA E LUNETA

| COD | UN. | A |
|-------|-----|--|
| 69258 | 6 | 8, 10, 12, 14, 17, 19 |
| 69259 | 8 | 8, 10, 12, 13, 14, 17, 19, 22 |
| 69273 | 10 | 8, 9, 10, 11, 12, 13, 14, 17, 19, 22 |
| 69274 | 12 | 6, 7, 8, 9, 10, 11, 12, 13, 14, 15, 16, 17 |
| 69261 | 14 | 10, 11, 12, 14, 16, 17, 19, 20, 22, 24, 25, 27, 28, 32 |
| 69275 | 17 | 6, 7, 8, 9, 10, 11, 12, 13, 14, 15, 16, 17, 18, 19, 20, 21, 22 |
| 69552 | 17 | 7, 8, 9, 10, 11, 12, 13, 14, 15, 16, 17, 18, 19, 20, 21, 22, 24 |
| 69276 | 26 | 6, 7, 8, 9, 10, 11, 12, 13, 14, 15, 16, 17, 18, 19, 20, 21, 22, 23, 24, 25, 26, 27, 28, 29, 30, 32 |

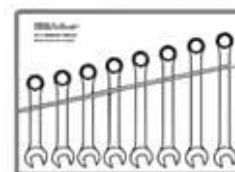

| COD | UN. | B |
|-------|-----|--|
| 69262 | 6 | 8, 10, 12, 14, 17, 19 |
| 69263 | 8 | 8, 10, 12, 13, 14, 17, 19, 22 |
| 69277 | 10 | 8, 9, 10, 11, 12, 13, 14, 17, 19, 22 |
| 69278 | 12 | 6, 7, 8, 9, 10, 11, 12, 13, 14, 15, 16, 17 |
| 69265 | 14 | 10, 11, 12, 14, 16, 17, 19, 20, 22, 24, 25, 27, 28, 32 |
| 69796 | 14 | 10, 11, 12, 14, 16, 17, 19, 20, 22, 24, 25, 27, 30, 32 |
| 69279 | 17 | 6, 7, 8, 9, 10, 11, 12, 13, 14, 15, 16, 17, 18, 19, 20, 21, 22 |
| 69556 | 17 | 7, 8, 9, 10, 11, 12, 13, 14, 15, 16, 17, 18, 19, 20, 21, 22, 24 |
| 69280 | 26 | 6, 7, 8, 9, 10, 11, 12, 13, 14, 15, 16, 17, 18, 19, 20, 21, 22, 23, 24, 25, 26, 27, 28, 29, 30, 32 |

LLAVES ACODADAS / DOUBLE OFFSET RING WRENCHES / CLES POLYGONALES / RINGSCHLÜSSEL / CHIAVI POLIGONALI / RINGSLEUTELS / CHAVES LUNETA

| COD | UN. | A |
|-------|-----|--|
| 69252 | 6 | 6-7, 8-9, 10-11, 12-13, 14-15, 16-17 |
| 69238 | 8 | 6-7, 8-9, 10-11, 12-13, 14-15, 16-17, 18-19, 20-22 |
| 69253 | 10 | 6-7, 8-9, 10-11, 12-13, 14-15, 16-17, 18-19, 20-22, 21-23, 24-26 |
| 69254 | 12 | 6-7, 8-9, 10-11, 12-13, 14-15, 16-17, 18-19, 20-22, 21-23, 24-26, 25-28, 30-32 |

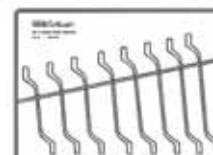

| COD | UN. | B |
|-------|-----|--|
| 69255 | 6 | 6-7, 8-9, 10-11, 12-13, 14-15, 16-17 |
| 69239 | 8 | 6-7, 8-9, 10-11, 12-13, 14-15, 16-17, 18-19, 20-22 |
| 69256 | 10 | 6-7, 8-9, 10-11, 12-13, 14-15, 16-17, 18-19, 20-22, 21-23, 24-26 |
| 69257 | 12 | 6-7, 8-9, 10-11, 12-13, 14-15, 16-17, 18-19, 20-22, 21-23, 24-26, 25-28, 30-32 |

A cromado pulido espejo / mirror polished chrome plating / polie chromée / poliert verchromt / cromate lucide gepolijst en verchromd / cromado polido

B cromado aeroespacial / aerospaceal chrome plating / chromée aérospatiale / verchromt aerospaceal cromate satinete / verchromd aerospaceal / cromado fosco aerospaceal

SETS

LLAVES FIJAS / OPEN-END WRENCHES / CLES PLATES / GABELSCHLÜSSEL / CHIAVI FISSE / STEEKSLEUTELS / CHAVES DUAS BOCAS

| COD | UN. | A |
|-------|-----|---|
| 69310 | 6 | 3/8-7/16, 1/2-9/16, 9/16-5/8, 19/32-11/16, 5/8-11/16, 13/16-7/8 |
| 69311 | 8 | 3/8-7/16, 1/2-9/16, 9/16-5/8, 19/32-11/16, 5/8-11/16, 3/4-7/8, 13/16-7/8, 15/16-1 |
| 69312 | 10 | 1/4-5/16, 5/16-3/8, 3/8-7/16, 1/2-9/16, 9/16-5/8, 5/8-11/16, 13/16-7/8, 15/16-1, 1-1.1/8, 1.1/16-1.1/4 |
| 69313 | 12 | 1/4-5/16, 5/16-3/8, 3/8-7/16, 1/2-9/16, 9/16-5/8, 5/8-11/16, 3/4-7/8, 13/16-7/8, 15/16-1, 1-1.1/8, 1.1/16-1.1/8, 1.1/16-1.1/4 |

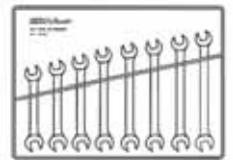

LLAVES COMBINADAS / COMBINATION WRENCHES / CLES MIXTES / RINGGABELSCHLÜSSEL / CHIAVI COMBinate / RINGSTEEKSLEUTELS / CHAVES BOCA E LUNETA

| COD | UN. | A |
|-------|-----|---|
| 69330 | 6 | 3/8, 7/16, 1/2, 9/16, 5/8, 3/4 |
| 69331 | 8 | 5/16, 3/8, 7/16, 1/2, 9/16, 5/8, 11/16, 3/4 |
| 69332 | 10 | 3/8, 7/16, 1/2, 9/16, 5/8, 11/16, 3/4, 13/16, 7/8, 1 |
| 69333 | 12 | 5/16, 3/8, 7/16, 1/2, 9/16, 5/8, 11/16, 3/4, 13/16, 7/8, 15/16, 1 |
| 69334 | 14 | 3/8, 7/16, 1/2, 9/16, 5/8, 11/16, 3/4, 13/16, 7/8, 15/16, 1, 1.1/16, 1.1/8, 1.1/4 |
| 69335 | 17 | 1/4, 5/16, 3/8, 7/16, 1/2, 9/16, 19/32, 5/8, 11/16, 3/4, 25/32, 13/16, 7/8, 15/16, 1, 1.1/16, 1.1/8 |

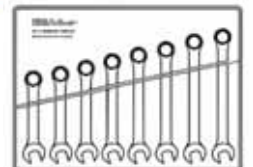

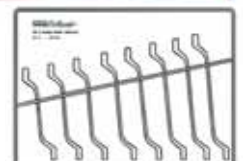

LLAVES ACODADAS / DOUBLE OFFSET RING WRENCHES / CLES POLYGOALES / RINGSCHLÜSSEL / CHIAVI POLIGONALI / RINGSLEUTELS / CHAVES LUNETA

| COD | UN. | A |
|-------|-----|---|
| 69320 | 6 | 3/8-7/16, 1/2-9/16, 9/16-5/8, 19/32-11/16, 5/8-11/16, 13/16-7/8 |
| 69321 | 8 | 3/8-7/16, 1/2-9/16, 9/16-5/8, 19/32-11/16, 5/8-11/16, 3/4-7/8, 13/16-7/8, 15/16-1 |
| 69322 | 10 | 1/4-5/16, 5/16-3/8, 3/8-7/16, 1/2-9/16, 9/16-5/8, 5/8-11/16, 13/16-7/8, 15/16-1, 1-1.1/8, 1.1/16-1.1/4 |
| 69323 | 12 | 1/4-5/16, 5/16-3/8, 3/8-7/16, 1/2-9/16, 9/16-5/8, 5/8-11/16, 3/4-7/8, 13/16-7/8, 15/16-1, 1-1.1/8, 1.1/16-1.1/8, 1.1/16-1.1/4 |





SETS

| COD | UN. |  | A |
|-------|-----|---|--|
| 68451 | 6 | | 6-7, 8-9, 10-11, 12-13, 14-15, 16-17 |
| 69444 | 8 | | 6-7, 8-9, 10-11, 12-13, 14-15, 16-17, 18-19, 20-22 |
| 68452 | 10 | | 6-7, 8-9, 10-11, 12-13, 14-15, 16-17, 18-19, 20-22, 21-23, 24-26 |
| 69445 | 12 | | 6-7, 8-9, 10-11, 12-13, 14-15, 16-17, 18-19, 20-22, 21-23, 24-26, 25-28, 30-32 |

| COD | UN. |  | B |
|-------|-----|---|--|
| 68453 | 6 | | 6-7, 8-9, 10-11, 12-13, 14-15, 16-17 |
| 69446 | 8 | | 6-7, 8-9, 10-11, 12-13, 14-15, 16-17, 18-19, 20-22 |
| 68454 | 10 | | 6-7, 8-9, 10-11, 12-13, 14-15, 16-17, 18-19, 20-22, 21-23, 24-26 |
| 69447 | 12 | | 6-7, 8-9, 10-11, 12-13, 14-15, 16-17, 18-19, 20-22, 21-23, 24-26, 25-28, 30-32 |

| COD | UN. |  | A |
|-------|-----|---|--|
| 68455 | 6 | | 8, 10, 12, 14, 17, 19 |
| 69448 | 8 | | 8, 9, 10, 11, 12, 14, 17, 19 |
| 68458 | 10 | | 8, 9, 10, 11, 12, 13, 14, 17, 19, 22 |
| 69449 | 12 | | 6, 7, 8, 9, 10, 11, 12, 13, 14, 15, 16, 17 |

| COD | UN. |  | B |
|-------|-----|---|--|
| 68457 | 6 | | 8, 10, 12, 14, 17, 19 |
| 69450 | 8 | | 8, 9, 10, 11, 12, 14, 17, 19 |
| 68456 | 10 | | 8, 9, 10, 11, 12, 13, 14, 17, 19, 22 |
| 69451 | 12 | | 6, 7, 8, 9, 10, 11, 12, 13, 14, 15, 16, 17 |

| COD | UN. |  | A |
|-------|-----|---|--|
| 68459 | 6 | | 6-7, 8-9, 10-11, 12-13, 14-15, 16-17 |
| 68460 | 8 | | 6-7, 8-9, 10-11, 12-13, 14-15, 16-17, 18-19, 20-22 |
| 68461 | 10 | | 6-7, 8-9, 10-11, 12-13, 14-15, 16-17, 18-19, 20-22, 21-23, 24-26 |
| 68462 | 12 | | 6-7, 8-9, 10-11, 12-13, 14-15, 16-17, 18-19, 20-22, 21-23, 24-26, 25-28, 30-32 |

| COD | UN. |  | B |
|-------|-----|---|--|
| 68463 | 6 | | 6-7, 8-9, 10-11, 12-13, 14-15, 16-17 |
| 69464 | 8 | | 6-7, 8-9, 10-11, 12-13, 14-15, 16-17, 18-19, 20-22 |
| 68465 | 10 | | 6-7, 8-9, 10-11, 12-13, 14-15, 16-17, 18-19, 20-22, 21-23, 24-26 |
| 69466 | 12 | | 6-7, 8-9, 10-11, 12-13, 14-15, 16-17, 18-19, 20-22, 21-23, 24-26, 25-28, 30-32 |



SETS

| COD | UN. |  | A |
|-------|-----|---|--|
| 69456 | 8 | | 6-7, 8-9, 10-11, 12-13, 14-15, 16-17, 18-19, 20-22 |
| 69470 | 12 | | 6-7, 8-9, 10-11, 12-13, 14-15, 16-17, 18-19, 20-22, 21-23, 24-26, 25-28, 30-32 |

| COD | UN. |  | B |
|-------|-----|---|--|
| 69457 | 8 | | 6-7, 8-9, 10-11, 12-13, 14-15, 16-17, 18-19, 20-22 |
| 69471 | 12 | | 6-7, 8-9, 10-11, 12-13, 14-15, 16-17, 18-19, 20-22, 21-23, 24-26, 25-28, 30-32 |

| COD | UN. |  | A |
|-------|-----|---|--|
| 69458 | 8 | | 8, 9, 10, 11, 12, 14, 17, 19 |
| 69472 | 12 | | 6, 7, 8, 9, 10, 11, 12, 13, 14, 15, 16, 17 |

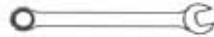
| COD | UN. |  | B |
|-------|-----|---|--|
| 69459 | 8 | | 8, 9, 10, 11, 12, 14, 17, 19 |
| 69473 | 12 | | 6, 7, 8, 9, 10, 11, 12, 13, 14, 15, 16, 17 |





A cromado pulido espejo / mirror polished chrome plating / polie chromée / poliert verchromt / cromate lucide gepolijst en verchromd / cromado pulido

B cromado aeroespacial / aerospaceal chrome plating / chromée aérospatiale / verchromt aerospaceal / cromate satinée / verchromd aerospaceal / cromado fosco aeroespacial



SETS

| COD | UN. |  | A |
|-------|-----|---|---|
| 68467 | 6 | 5/16-3/8, 3/8-7/16, 1/2-9/16, 9/16-5/8, 19/32-11/16, 5/8-11/16 | |
| 69452 | 8 | 5/16-3/8, 3/8-7/16, 1/2-9/16, 9/16-5/8, 19/32-11/16, 5/8-11/16, 3/4-7/8, 13/16-7/8 | |
| 68468 | 10 | 1/4-5/16, 5/16-3/8, 3/8-7/16, 1/2-9/16, 9/16-5/8, 5/8-11/16, 13/16-7/8, 15/16-1, 1-1.1/8, 1.1/16-1.1/4 | |
| 69453 | 12 | 1/4-5/16, 5/16-3/8, 3/8-7/16, 1/2-9/16, 9/16-5/8, 5/8-11/16, 3/4-7/8, 13/16-7/8, 15/16-1, 1-1.1/8, 1.1/16-1.1/8, 1.1/16-1.1/4 | |

| COD | UN. |  | A |
|-------|-----|---|---|
| 68469 | 6 | 3/8, 7/16, 1/2, 9/16, 5/8, 3/4 | |
| 69454 | 8 | 5/16, 3/8, 7/16, 1/2, 9/16, 5/8, 11/16, 3/4 | |
| 68470 | 10 | 3/8, 7/16, 1/2, 9/16, 5/8, 11/16, 3/4, 13/16, 7/8 | |
| 69455 | 12 | 5/16, 3/8, 7/16, 1/2, 9/16, 5/8, 11/16, 3/4, 13/16, 7/8, 15/16, 1 | |



| COD | UN. |  | A |
|-------|-----|---|---|
| 68471 | 6 | 3/8-7/16, 1/2-9/16, 9/16-5/8, 19/32-11/16, 5/8-11/16, 13/16-7/8 | |
| 68472 | 8 | 3/8-7/16, 1/2-9/16, 9/16-5/8, 19/32-11/16, 5/8-11/16, 3/4-7/8, 13/16-7/8, 15/16-1 | |
| 68473 | 10 | 1/4-5/16, 5/16-3/8, 3/8-7/16, 1/2-9/16, 9/16-5/8, 5/8-11/16, 13/16-7/8, 15/16-1, 1-1.1/8, 1.1/16-1.1/4 | |
| 68474 | 12 | 1/4-5/16, 5/16-3/8, 3/8-7/16, 1/2-9/16, 9/16-5/8, 5/8-11/16, 3/4-7/8, 13/16-7/8, 15/16-1, 1-1.1/8, 1.1/16-1.1/8, 1.1/16-1.1/4 | |

SETS

| COD | UN. |  | A |
|-------|-----|---|---|
| 69460 | 8 | 5/16-3/8, 3/8-7/16, 1/2-9/16, 9/16-5/8, 19/32-11/16, 5/8-11/16, 3/4-7/8, 13/16-7/8 | |
| 69474 | 12 | 1/4-5/16, 5/16-3/8, 3/8-7/16, 1/2-9/16, 9/16-5/8, 5/8-11/16, 3/4-7/8, 13/16-7/8, 15/16-1, 1-1.1/8, 1.1/16-1.1/8, 1.1/16-1.1/4 | |

| COD | UN. |  | A |
|-------|-----|---|---|
| 69461 | 8 | 5/16, 3/8, 7/16, 1/2, 9/16, 5/8, 11/16, 3/4 | |
| 69475 | 12 | 5/16, 3/8, 7/16, 1/2, 9/16, 5/8, 11/16, 3/4, 13/16, 7/8, 15/16, 1 | |



LLAVE DINAMOMETRICA REVERSIBLE / REVERSIBLE TORQUE WRENCH / CLÉ DYNAMOMÉTRIQUE REVERSIBLE / UMKEHRBARER DREHMOMENT-SCHRAUBENSCHLÜSSEL / CHIAVE DINAMOMETRICA REVERSIBILE / REVERSIBILE TORSIEMOERSLEUTEL / CHAVE DINAMOMÉTRICA REVERSÍVEL

| COD | | N.m | Lb.ft | | | |
|-------|------|--------|--------|-----|------|---|
| 61207 | 3/8" | 20-110 | 15-80 | 404 | 1,05 | 1 |
| 61208 | | | | | | |
| 61209 | 1/2" | 30-210 | 20-150 | 490 | 1,6 | |
| 61210 | | | | | | |

Especificaciones técnicas / Technical specification / Détails techniques

| | |
|--|----|
| Precisión / Accuracy / Précision | 3% |
| Certificado de calibración / Calibration certificate / Certificat de calibrage | ● |
| Reversible / Reversible / Réversible | ● |
| Dientes / Teeth / Dents | 32 |

| COD | | N.m | | | |
|-------|------|---------|------|-----|---|
| 61211 | 3/4" | 140-700 | 1060 | 6,5 | 1 |
| 61212 | 1" | 140-980 | 1120 | 7 | |

Especificaciones técnicas / Technical specification / Détails techniques

| | |
|--|----|
| Precisión / Accuracy / Précision | 3% |
| Certificado de calibración / Calibration certificate / Certificat de calibrage | ● |
| Reversible / Reversible / Réversible | ● |
| Dientes / Teeth / Dents | 32 |

| COD | | N.m | | | | |
|-------|------|------------------------------|--------|-----|-----|-----|
| 61225 | 1/2" | 17-22-24-26-27-29mm | 19-110 | 535 | 1,3 | |
| 61226 | | 13-14-15-17-19-22-24-27-30mm | | | | |
| 61227 | 3/8" | 17-22-24-26-27-29mm | 40-210 | 575 | | 1,7 |
| 61228 | | 13-14-15-17-19-22-24-27-30mm | | | | |

Especificaciones técnicas / Technical specification / Détails techniques

| | |
|---|---------|
| Precisión / Accuracy / Précision | 3% |
| Certificado de calibración / Calibration certificate / Certificat de calibrage | ● |
| Reversible / Reversible / Réversible | ● |
| Dientes / Teeth / Dents | 24 |
| Dimensiones unión / Joint Dimensions / Dimension de l'union | 14x18mm |
| Sistema de cabezas fijas + carraca / Ratchet + open head system Système de têtes fixes + cliquet | ● |

| COD | |
|-------|------|
| 65384 | 3/8" |
| 65385 | 1/2" |

| COD | |
|-------|------|
| 65369 | 13mm |
| 65370 | 14mm |
| 65371 | 15mm |
| 65372 | 16mm |
| 65373 | 17mm |
| 65374 | 18mm |
| 65375 | 19mm |
| 65376 | 21mm |

| COD | |
|-------|------|
| 65377 | 22mm |
| 65378 | 24mm |
| 65379 | 26mm |
| 65380 | 27mm |
| 65381 | 29mm |
| 65382 | 30mm |
| 65383 | 32mm |



LLAVES / WRENCHES / CLES / SCHLÜSSEL / CHIAVI / SLEUTELS / CHAVES

COMBINADA ACODADA / COMBINATION DEEP OFFSET SPANNER / MIXTE CONTRECOUDEE / RINGMAULSCHLÜSSEL / CHIAVE COMBINATA A CONTROGOMITO / RINGSTEEKSLEUTEL, AFGEBOGEN / BOCA ELUNETA CONTRA-COTOVELO

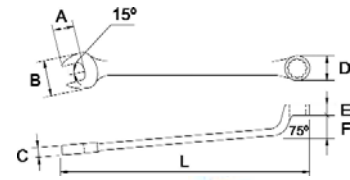

| COD | B | L | A | B | C | D | E | F | | | |
|-------|----|-----|------|------|------|------|------|------|-----|----|---|
| 60740 | 6 | 114 | 9,6 | 17 | 3,7 | 12,1 | 5,9 | 4,7 | 17 | 10 | 1 |
| 60741 | 7 | 126 | 10,3 | 19,8 | 4,1 | 13,2 | 6,5 | 5,4 | 25 | | |
| 60742 | 8 | 139 | 11 | 22,6 | 4,5 | 14,3 | 7,3 | 6,1 | 23 | | |
| 60743 | 9 | 145 | 11,5 | 22,9 | 4,5 | 14,9 | 7,7 | 6,8 | 40 | | |
| 60744 | 10 | 152 | 12,1 | 23,2 | 4,6 | 15,6 | 8,2 | 7,5 | 43 | | |
| 60745 | 11 | 169 | 13,6 | 26,8 | 5,1 | 17,9 | 8,7 | 8 | 65 | | |
| 60746 | 12 | 186 | 15,2 | 30,4 | 5,7 | 20,3 | 9,2 | 8,5 | 67 | | |
| 60747 | 13 | 191 | 15,8 | 30,5 | 5,7 | 21,1 | 9,5 | 12,1 | 90 | | |
| 60748 | 14 | 197 | 16,5 | 30,6 | 5,8 | 21,9 | 9,8 | 15,7 | 95 | | |
| 60749 | 15 | 214 | 17,7 | 34,7 | 6 | 24,1 | 10,1 | 17,7 | 115 | | |
| 60750 | 16 | 231 | 18,9 | 38,9 | 8,3 | 26,3 | 12,4 | 19,8 | 130 | | |
| 60751 | 17 | 246 | 19,7 | 38,4 | 8,5 | 27,5 | 12,4 | 20 | 170 | | |
| 60752 | 18 | 262 | 20,6 | 39,6 | 8,6 | 28,6 | 12,5 | 21,2 | 175 | | |
| 60753 | 19 | 276 | 21,8 | 42,8 | 8,7 | 30,8 | 13,1 | 22,7 | 240 | | |
| 60755 | 21 | 290 | 23,1 | 46 | 8,8 | 33,1 | 13,8 | 24,3 | 250 | | |
| 60756 | 22 | 297 | 23,4 | 46,7 | 9 | 33,7 | 14 | 24,8 | 270 | | |
| 60757 | 23 | 305 | 23,8 | 47,4 | 9,2 | 34,4 | 14,2 | 25,4 | 320 | | |
| 60758 | 24 | 323 | 26,3 | 49,5 | 9,4 | 36,4 | 14,6 | 25,7 | 355 | | |
| 60759 | 25 | 341 | 28,1 | 51,6 | 9,7 | 38,4 | 14,8 | 30,2 | 380 | | |
| 60760 | 26 | 352 | 28,5 | 52,6 | 9,9 | 38,5 | 14,8 | 30,3 | 425 | | |
| 60761 | 27 | 363 | 28,8 | 53,6 | 10,2 | 38,6 | 14,9 | 30,5 | 410 | | |
| 60762 | 28 | 374 | 30,2 | 61,4 | 10,5 | 41,6 | 16,5 | 32,4 | 470 | | |
| 60763 | 29 | 385 | 31,6 | 62,2 | 10,9 | 44,6 | 18,1 | 34,4 | 550 | | |
| 60764 | 30 | 398 | 32,7 | 65,4 | 11 | 45,9 | 18,3 | 34,5 | 615 | | |
| 60765 | 32 | 412 | 33,9 | 68 | 11,2 | 47,2 | 18,6 | 34,7 | 740 | | |

Cr-V DIN 3113-B

ESTRELLA PLANA / DOUBLE ENDED FLAT RING SPANNER / POLYGONALE A DROITE / DOPPELRINGSCHLÜSSEL / POLIGONALE DIRITTA / RINSLEUTEL, PLAT / LUNETA DIREITA



| COD | B | L | A | B | C | D | | | |
|-------|-------|-----|------|------|------|------|-----|----|---|
| 60770 | 6-7 | 91 | 9,7 | 3,4 | 11,6 | 4,4 | 5 | 10 | 1 |
| 60771 | 8-9 | 105 | 12,4 | 5,5 | 13,8 | 5,6 | 10 | | |
| 60772 | 10-11 | 123 | 14,7 | 6,1 | 16,2 | 6,2 | 23 | | |
| 60773 | 12-13 | 126 | 15,8 | 6,1 | 18,4 | 7,4 | 35 | | |
| 60774 | 14-15 | 145 | 19,8 | 7,3 | 21,4 | 7,9 | 55 | | |
| 60775 | 16-17 | 161 | 23,8 | 8,4 | 25,4 | 8,7 | 60 | | |
| 60776 | 17-19 | 176 | 27,1 | 9,2 | 28,3 | 9,1 | 65 | | |
| 60777 | 18-19 | 176 | 27,2 | 8,8 | 28,3 | 9,2 | 75 | | |
| 60778 | 20-22 | 177 | 28,5 | 8,9 | 28,4 | 9,3 | 145 | | |
| 60779 | 21-23 | 214 | 29,9 | 11,2 | 33,9 | 11,3 | 160 | | |
| 60780 | 24-27 | 249 | 34,9 | 11,9 | 39,1 | 12,1 | 200 | | |
| 60781 | 25-28 | 263 | 36,1 | 13,4 | 41,1 | 12,6 | 300 | | |
| 60782 | 30-32 | 294 | 43,2 | 13,5 | 45,8 | 13,6 | 375 | | |

Cr-V DIN 837

MEDIA LUNA / HALF MOON / DEMI-LUNE / STARTER BLOCKSCHLÜSSEL / A MEZZALUNA / STARTMOTORSLEUTEL / MEIA-LUNA

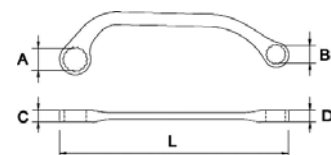

| COD | B | L | A | B | C | D | | | |
|-------|-------|-----|----|----|----|----|-----|----|---|
| 60795 | 11-13 | 150 | 11 | 13 | 6 | 8 | 75 | 10 | 1 |
| 60796 | 13-17 | 184 | 13 | 17 | 9 | 10 | 95 | | |
| 60797 | 14-17 | 188 | 14 | 17 | 9 | 10 | 90 | | |
| 60798 | 19-22 | 233 | 19 | 22 | 10 | 11 | 165 | | |

Cr-V DIN 475

PARA RACORES / FLARE NUT / POLYGONALE A TUYATEUR / OFFENER DOPPELRINGSCHLÜSSEL / CHIAVE PER RACCORDI / RINGSLEUTEL MET KRAAG / LUNETAS ABERTAS COM BATENTE

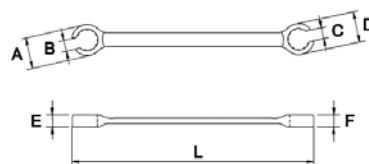

| COD | B | L | A | B | C | D | E | F | GR | 10 | 5 |
|-------|-------|-----|------|------|------|------|------|------|-----|----|---|
| 60785 | 8-10 | 145 | 18,7 | 6,2 | 7,2 | 21,1 | 7,3 | 8,6 | 45 | 10 | 1 |
| 60786 | 9-11 | 153 | 21 | 6,6 | 8,8 | 22,5 | 8,6 | 8,9 | 55 | | |
| 60787 | 10-11 | 153 | 21,1 | 7,3 | 8,9 | 22,7 | 8,6 | 8,8 | 100 | | |
| 60788 | 11-13 | 165 | 22,5 | 8,6 | 10,2 | 25,5 | 8,6 | 10,5 | 165 | | |
| 60789 | 12-14 | 179 | 25 | 9,6 | 11,2 | 27,7 | 9 | 11 | 200 | | |
| 60790 | 17-19 | 210 | 30,9 | 14,4 | 15,4 | 33,9 | 11,6 | 12,6 | 290 | 5 | 1 |
| 60791 | 19-22 | 235 | 33,8 | 18,4 | 17,4 | 38,8 | 13,6 | 16 | 280 | | |
| 60792 | 22-24 | 250 | 38,6 | 17,5 | 18,5 | 41,6 | 15,3 | 16,3 | 460 | | |
| 60793 | 24-27 | 265 | 41,8 | 18,5 | 20,8 | 46 | 16 | 17 | 460 | | |
| 60794 | 30-32 | 280 | 48,3 | 22 | 24 | 51 | 20,5 | 22,7 | 460 | | |

Cr-V DIN 3118

FIJA / OPEN-END / A FOURCHE / DOPPELMAULSCHLÜSSEL / CHIAVE FISSE / STEEKSLEUTEL / DUAS BOCAS

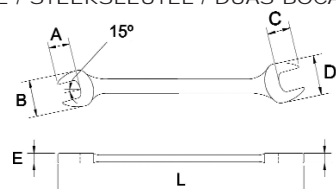

| COD | B | L | A | B | C | D | E | F | GR | 10 | 5 | 1 |
|-------|-------|-----|------|-------|------|-------|------|------|------|----|---|---|
| 60800 | 6-7 | 95 | 6,5 | 14,1 | 7,6 | 16,5 | 3,2 | 3,5 | 20 | 10 | 1 | |
| 60801 | 7-8 | 101 | 8,3 | 16,8 | 8,6 | 19,1 | 4,1 | 3,8 | 23 | | | |
| 60802 | 8-9 | 103 | 8,7 | 18,3 | 9,2 | 20,3 | 4,3 | 4,2 | 32 | | | |
| 60803 | 8-10 | 114 | 8,9 | 18,4 | 10,4 | 21,3 | 4,4 | 4,4 | 30 | | | |
| 60804 | 9-11 | 123 | 10,6 | 19,4 | 11,9 | 22,9 | 4,6 | 4,9 | 35 | | | |
| 60805 | 10-11 | 125 | 10,6 | 21,2 | 12,3 | 23,4 | 4,9 | 5,1 | 35 | | | |
| 60806 | 10-12 | 128 | 11,2 | 22,4 | 12,6 | 25,6 | 5,1 | 5,2 | 40 | | | |
| 60807 | 10-13 | 130 | 11,3 | 22,5 | 13,3 | 27,9 | 5,3 | 5,3 | 40 | | | |
| 60808 | 11-13 | 134 | 11,8 | 25,3 | 13,5 | 28,4 | 5,4 | 5,4 | 50 | | | |
| 60809 | 12-13 | 135 | 11,9 | 25,3 | 14,1 | 28,5 | 5,5 | 5,5 | 50 | | | |
| 60810 | 12-14 | 140 | 12,1 | 27,5 | 14,4 | 30,7 | 5,5 | 5,6 | 45 | | | |
| 60811 | 13-14 | 147 | 12,5 | 27,5 | 14,5 | 30,9 | 5,6 | 5,7 | 55 | | | |
| 60812 | 13-15 | 151 | 13,8 | 28,5 | 15 | 31,3 | 5,8 | 5,8 | 70 | | | |
| 60813 | 13-16 | 152 | 13,9 | 28,7 | 15,4 | 34,1 | 6 | 6,1 | 68 | | | |
| 60814 | 14-15 | 153 | 14,3 | 28,8 | 15,6 | 34,3 | 6,1 | 6,2 | 75 | | | |
| 60815 | 13-17 | 155 | 14,4 | 28,9 | 16,1 | 34,5 | 6,1 | 6,3 | 78 | | | |
| 60816 | 14-17 | 156 | 14,5 | 29,1 | 18,1 | 34,6 | 6,2 | 6,4 | 80 | | | |
| 60817 | 16-17 | 157 | 15,8 | 33,4 | 18,3 | 34,7 | 6,3 | 6,5 | 50 | | | |
| 60818 | 16-18 | 160 | 16,2 | 33,6 | 18,5 | 35,5 | 6,4 | 6,5 | 112 | | | |
| 60819 | 17-19 | 170 | 16,3 | 35,3 | 19,3 | 36,5 | 7 | 7,3 | 133 | | | |
| 60820 | 18-19 | 172 | 16,5 | 35,4 | 20,3 | 37,7 | 7,1 | 7,4 | 130 | | | |
| 60821 | 18-21 | 180 | 17,8 | 35,9 | 21,6 | 38,9 | 7,2 | 7,6 | 138 | | | |
| 60822 | 17-22 | 182 | 17,9 | 35,9 | 21,7 | 44,5 | 7,2 | 7,9 | 140 | | | |
| 60823 | 19-22 | 191 | 18,7 | 37,1 | 21,7 | 45,4 | 8,1 | 8,2 | 170 | | | |
| 60824 | 20-22 | 193 | 19,5 | 38,5 | 21,8 | 45,5 | 8,4 | 8,4 | 165 | | | |
| 60825 | 19-24 | 206 | 20,1 | 38,9 | 22,5 | 45,7 | 8,6 | 8,6 | 180 | | | |
| 60826 | 21-23 | 219 | 22,4 | 44,1 | 22,8 | 48,3 | 8,7 | 8,8 | 200 | | | |
| 60827 | 21-24 | 219 | 22,6 | 44,3 | 23,6 | 48,5 | 8,7 | 8,8 | 200 | | | |
| 60828 | 22-24 | 220 | 22,7 | 44,3 | 23,8 | 48,9 | 9,1 | 8,9 | 205 | | | |
| 60829 | 22-27 | 237 | 24,2 | 48,5 | 25,3 | 52,3 | 9,2 | 9,1 | 235 | | | |
| 60830 | 24-27 | 238 | 24,3 | 48,7 | 26,1 | 53,7 | 9,5 | 9,7 | 260 | | | |
| 60831 | 25-28 | 247 | 24,6 | 51,2 | 27,7 | 57,3 | 9,7 | 9,8 | 350 | | | |
| 60832 | 24-30 | 262 | 24,7 | 52,3 | 29,4 | 60,4 | 10,1 | 10,1 | 340 | | | |
| 60833 | 27-30 | 266 | 26,4 | 55,6 | 29,5 | 61,3 | 10,2 | 10,3 | 345 | | | |
| 60834 | 27-32 | 270 | 27,7 | 58,7 | 29,8 | 62,7 | 10,5 | 10,5 | 400 | | | |
| 60835 | 30-32 | 273 | 28,3 | 60,1 | 30,3 | 64,5 | 10,9 | 10,7 | 455 | | | |
| 60836 | 30-34 | 288 | 28,6 | 60,2 | 32,1 | 68,4 | 11,8 | 12,5 | 520 | | | |
| 60837 | 30-36 | 303 | 29,5 | 61,3 | 35,4 | 71,7 | 12,1 | 12,7 | 605 | | | |
| 60838 | 32-36 | 304 | 30,3 | 63,2 | 36,1 | 72,1 | 12,4 | 12,9 | 670 | | | |
| 60839 | 34-36 | 308 | 33,4 | 69,1 | 37,5 | 73,2 | 12,5 | 13,5 | 720 | | | |
| 60840 | 36-41 | 341 | 36,6 | 73,4 | 42,5 | 84,4 | 13,8 | 13,7 | 750 | | | |
| 60841 | 41-46 | 373 | 40,8 | 82,1 | 42,8 | 91,1 | 14,9 | 14,5 | 915 | | | |
| 60842 | 46-50 | 402 | 48,1 | 92,5 | 51,9 | 98,9 | 15,1 | 14,7 | 1515 | | | |
| 60843 | 50-55 | 453 | 48,3 | 101,8 | 53,8 | 108,9 | 16,6 | 15,4 | 1600 | | | |

DIN 895









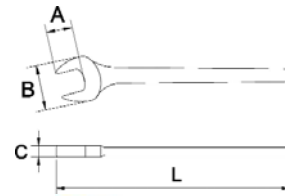

7

LLAVES / WRENCHES / CLES / SCHLÜSSEL / CHIAVI / SLEUTELS / CHAVES

FIJA UNA BOCA / SINGLE ENDED OPEN JAW SPANNER / A FOURCHE / EINMAULSCHLÜSSEL / FISSE SEMPLICE / ENKELVOUDIGE STEEKSLEUTEL / FIXA DE UMA BOCA



| COD |  |  |  |  |  |  |  |  |
|-------|---|---|---|---|--|---|---|---|
| 60844 | 8 | 92 | 7,1 | 17,5 | 3,8 | 15 | 10 | 1 |
| 60845 | 9 | 99 | 9,6 | 20,2 | 3,9 | 18 | | |
| 60846 | 10 | 106 | 11,1 | 21,7 | 4,7 | 20 | | |
| 60847 | 11 | 109 | 11,8 | 22,6 | 5,3 | 23 | | |
| 60848 | 12 | 125 | 13,4 | 25,3 | 5,4 | 27 | | |
| 60849 | 13 | 130 | 14,2 | 28,3 | 5,8 | 37 | | |
| 60850 | 14 | 140 | 14,8 | 28,7 | 6,1 | 42 | | |
| 60851 | 15 | 151 | 15,2 | 32,2 | 6,2 | 42 | | |
| 60852 | 16 | 154 | 16,3 | 32,4 | 6,3 | 42 | | |
| 60853 | 17 | 159 | 17,5 | 34,5 | 6,5 | 58 | | |
| 60854 | 18 | 164 | 18,4 | 36,3 | 6,7 | 60 | | |
| 60855 | 19 | 170 | 19,6 | 38,9 | 7,4 | 75 | | |
| 60856 | 21 | 180 | 22,6 | 42,6 | 8,5 | 100 | | |
| 60857 | 22 | 193 | 23,1 | 45,3 | 8,7 | 120 | | |
| 60858 | 24 | 213 | 23,3 | 47,7 | 9,4 | 140 | | |
| 60859 | 27 | 238 | 27,1 | 54,1 | 10,2 | 180 | | |
| 60860 | 30 | 257 | 29,4 | 59,9 | 10,3 | 300 | | |
| 60861 | 32 | 273 | 32,1 | 63,4 | 12,1 | 315 | | |
| 60862 | 34 | 285 | 33,2 | 71,5 | 13,5 | 405 | | |
| 60863 | 36 | 298 | 37,2 | 71,6 | 13,7 | 420 | | |
| 60864 | 38 | 322 | 40,8 | 76,1 | 13,9 | 425 | | |
| 60865 | 41 | 345 | 42,1 | 83,2 | 14,5 | 570 | | |
| 60866 | 46 | 368 | 43,6 | 91,9 | 15,2 | 800 | | |
| 60867 | 50 | 392 | 50,4 | 98,3 | 15,8 | 1040 | | |
| 60868 | 55 | 440 | 54,6 | 109,4 | 17,1 | 1190 | | |
| 60869 | 60 | 473 | 58,5 | 121,5 | 17,5 | 1540 | | |
| 60870 | 65 | 522 | 61,3 | 131,5 | 18 | 1550 | | |

DIN 894



FIJA DE GOLPE / SLOGGING OPEN WRENCH / A FOURCHE A FRAPPER / SCHLAGMAULSCHLÜSSEL / FISSE AD IMPULSO
 STEEKSLAGSLEUTEL / BOCA DE IMPACTO

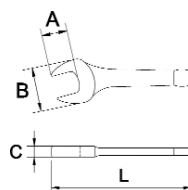

| COD | | | | | | | | |
|-------|----------|-----|------|-------|------|-------|---|---|
| 60871 | 24 | 150 | 24 | 50 | 12 | 0,35 | 5 | 1 |
| 60903 | 26 | 175 | 27 | 57 | 15 | | | |
| 60872 | 27 | 175 | 27 | 57 | 15 | | | |
| 60873 | 30 | 190 | 30 | 65 | 15,5 | 0,55 | 1 | - |
| 60874 | 32 | 190 | 32 | 66 | 16 | 0,61 | | |
| 60875 | 36 | 210 | 36 | 75 | 17 | 0,70 | | |
| 60876 | 41 | 230 | 41 | 87 | 18,5 | 0,93 | | |
| 60877 | 46 | 250 | 46 | 98 | 20 | 1,25 | | |
| 60878 | 50 | 275 | 50 | 108 | 20,5 | 1,68 | | |
| 60879 | 55 | 305 | 55 | 117 | 23 | 2,20 | | |
| 60880 | 60 | 315 | 60 | 128 | 23 | 2,54 | | |
| 60927 | 65 | 335 | 65 | 141 | 27,5 | 5 | | |
| 60928 | 70 | 370 | 70 | 156 | 28,5 | 5,10 | | |
| 60929 | 75 | 375 | 75 | 162 | 29 | 5,87 | | |
| 60930 | 80 | 400 | 85 | 174 | 32 | 6,80 | | |
| 60931 | 85 | 400 | 85 | 174 | 32 | | | |
| 60932 | 90 | 445 | 95 | 194 | 36 | 10,20 | | |
| 60933 | 95 | 445 | 95 | 194 | 36 | 10,50 | | |
| 60934 | 100 | 485 | 105 | 228 | 43 | 13,85 | | |
| 60935 | 105 | 485 | 105 | 228 | 43 | 13,90 | | |
| 60936 | 110 | 512 | 115 | 238 | 45 | 13,80 | | |
| 60937 | 115 | 512 | 115 | 238 | 45 | 18,60 | | |
| 60938 | 120 | 512 | 115 | 238 | 45 | 19,45 | | |
| 60966 | 1" | 175 | 27 | 57 | 15 | 0,15 | 5 | 1 |
| 60967 | 1.1/16" | 175 | 27 | 57 | 15 | 0,20 | | |
| 60968 | 1.3/16" | 190 | 30 | 65 | 15,5 | 0,24 | | |
| 60969 | 1.1/4" | 190 | 32 | 66 | 16 | 0,23 | 1 | - |
| 60970 | 1.5/8" | 230 | 41 | 87 | 18,5 | 7 | | |
| 60971 | 1.13/16" | 250 | 46 | 98 | 20 | 1,30 | | |
| 60972 | 2" | 275 | 47,6 | 106,6 | 23,2 | 1,82 | | |
| 60973 | 2.3/8" | 315 | 60 | 128 | 23 | 3,11 | | |
| 60974 | 2.9/16" | 335 | 65 | 141 | 27,5 | 3,30 | | |
| 60975 | 2.3/4" | 370 | 70 | 156 | 28,5 | 3,91 | | |
| 60976 | 2.15/16" | 375 | 75 | 162 | 29 | 5,26 | | |
| 60977 | 3" | 396 | 75 | 162 | 29 | 5,95 | | |
| 60978 | 3.1/8" | 400 | 85 | 174 | 32 | 6 | | |
| 60979 | 3.3/4" | 445 | 95 | 194 | 36 | 8,10 | | |
| 60980 | 4" | 485 | 105 | 228 | 43 | 13,55 | | |
| 60981 | 4.1/8" | 485 | 105 | 228 | 43 | 13,60 | | |
| 60982 | 4.1/2" | 512 | 115 | 238 | 45 | 18,69 | | |

Cr-V DIN 133

7

LLAVES / WRENCHES / CLES / SCHLÜSSEL / CHIAVI / SLEUTELS / CHAVES

ESTRELLA DE GOLPE / SLOGGING RING / POLYGONALE A FRAPPER / SCHLAG RINGSCHLÜSSEL / POLIGONALE AD IMPULSO
RINGSLAGSLEUTEL / LUNETA DE IMPACTO

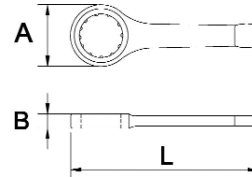

| COD | | L mm | A | B | C | Kg | | |
|-------|----------|---------|------|-----|------|-------|---|---|
| 60881 | 24 | 165 | 14 | 42 | 8,5 | 0,24 | | |
| 60904 | 26 | 175 | 16 | 46 | 9,5 | 0,28 | | |
| 60882 | 27 | 175 | 16 | 46 | 9,5 | 0,30 | 5 | 1 |
| 60883 | 30 | 185 | 16 | 53 | 10,5 | 0,44 | | |
| 60884 | 32 | 185 | 16 | 53 | 10,5 | 0,45 | | |
| 60885 | 36 | 205 | 19 | 58 | 11 | 0,50 | | |
| 60886 | 41 | 225 | 20 | 64 | 12 | 0,70 | | |
| 60887 | 42 | 225 | 20 | 64 | 12 | 0,80 | | |
| 60888 | 46 | 235 | 22 | 73 | 13 | 0,97 | | |
| 60889 | 50 | 250 | 23 | 78 | 13,5 | 1,04 | | |
| 60890 | 55 | 265 | 23,5 | 86 | 14 | 1,40 | | |
| 60891 | 60 | 274 | 25,5 | 92 | 15 | 1,63 | | |
| 60939 | 65 | 298 | 30 | 102 | 16 | 2,32 | | |
| 60940 | 70 | 320 | 31,5 | 108 | 17 | 2,50 | | |
| 60941 | 75 | 326 | 33 | 113 | 18 | 3,20 | 1 | - |
| 60942 | 80 | 350 | 34 | 124 | 19 | 3,60 | | |
| 60943 | 85 | 355 | 36 | 130 | 20 | 3,90 | | |
| 60944 | 90 | 390 | 39 | 142 | 23 | 7,43 | | |
| 60945 | 95 | 390 | 39 | 142 | 23 | 7,50 | | |
| 60946 | 100 | 420 | 43 | 155 | 25 | | | |
| 60947 | 105 | 420 | 43 | 155 | 25 | | | |
| 60948 | 110 | 450 | 45 | 168 | 28 | 9,60 | | |
| 60949 | 115 | 450 | 45 | 168 | 28 | | | |
| 60950 | 120 | 480 | 50 | 182 | 30 | 15,75 | | |
| 60983 | 1" | 165 | 14 | 42 | 8,5 | 0,26 | | |
| 60984 | 1.1/16" | 175 | 16 | 46 | 9,5 | 0,30 | 5 | 1 |
| 60985 | 1.3/16" | 185 | 16 | 53 | 10,5 | 0,44 | | |
| 60986 | 1.1/4" | 185 | 16 | 53 | 10,5 | 0,45 | | |
| 60987 | 1.5/8" | 225 | 20 | 64 | 12 | 0,70 | | |
| 60988 | 1.13/16" | 235 | 22 | 73 | 13 | 0,97 | | |
| 60989 | 2" | 250 | 23 | 78 | 13,5 | 1,08 | | |
| 60990 | 2.3/8" | 274 | 25,5 | 92 | 15 | 1,63 | | |
| 60991 | 2.9/16" | 298 | 30 | 102 | 16 | 2,32 | | |
| 60992 | 2.3/4" | 320 | 31,5 | 108 | 17 | 2,60 | | |
| 60993 | 2.15/16" | 326 | 33 | 113 | 18 | 3,34 | 1 | - |
| 60994 | 3" | 326 | 33 | 113 | 18 | 3,36 | | |
| 60995 | 3.1/8" | 350 | 34 | 124 | 19 | 3,79 | | |
| 60996 | 3.3/4" | 390 | 39 | 142 | 23 | 5,69 | | |
| 60997 | 4" | 420 | 43 | 158 | 25 | 6,81 | | |
| 60998 | 4.1/8" | 420 | 43 | 155 | 25 | 8,51 | | |
| 60999 | 4.1/2" | 450 | 45 | 168 | 28 | 9,50 | | |

Cr-V DIN 7444

LLAVE DE VALVULA / VALVE SPANNER / CLÉ DE SOUPAPE / VENTILSCHLÜSSEL / CHIAVE A VALVOLA / VENTIELSLEUTEL
CHAVE DE VÁLVULA



| COD | CAP (ØX) | ØY | L | Kg | |
|-------|----------|------|-----|------|---|
| 62803 | 2"-7" | 18mm | 215 | 0,23 | 1 |
| 62804 | 8"-15" | 24mm | 400 | 1,30 | |
| 62805 | 16"-20" | 30mm | 490 | 1,70 | |
| 62806 | | | 800 | 5,30 | |

LLAVE DE CARRACA PARA RACORES / RATCHETING RING WRENCH / CLE A TUYAUTER A CLIQUET / KNARRENROHRSCHLÜSSEL
OPEN RATELSLEUTEL / CHIAVE A CRICCO PER RACCORDI / CHAVE LUNETA ABERTA COM ROQUETE

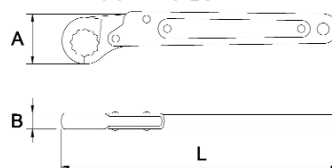

| COD | Ø | L | A | B | Kg | | |
|-------|----|-----|------|----|-----|---|---|
| 65089 | 10 | 136 | 24 | 7 | 80 | 6 | 1 |
| 65090 | 11 | 136 | 24 | 7 | 85 | | |
| 65091 | 12 | 136 | 24 | 7 | 85 | | |
| 65092 | 13 | 136 | 24 | 7 | 90 | | |
| 65093 | 14 | 136 | 24 | 7 | 90 | | |
| 65095 | 17 | 185 | 30,5 | 8 | 142 | | |
| 65096 | 19 | 185 | 32,5 | 8 | 180 | | |
| 65098 | 22 | 235 | 39 | 11 | 230 | | |
| 65099 | 24 | 235 | 39 | 11 | 230 | | |
| 65100 | 27 | 320 | 49,5 | 13 | 325 | | |
| 65102 | 32 | 320 | 50 | 18 | 325 | | |

LLAVE DE CARRACA PARA ESTRUCTURA METALICA / PODGING WRENCH / CLIQUET REVERSIBLE / STAHLBAUKNARRE
PODGE SLEUTEL / CHIAVE A CRICCO PER COSTRUZIONE / CHAVE DE ROQUETE PARA ESTRUTURA METALICA

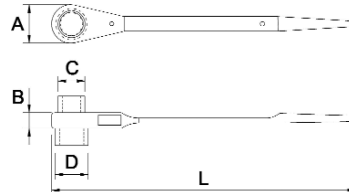

| COD | Ø | L | A | B | C | D | Kg | | |
|-------|---------------|-----|------|------|------|------|------|---|---|
| 65076 | 17-19 | 320 | 42,7 | 18,8 | 24,5 | 26,7 | 485 | 6 | 1 |
| 65077 | 19-22 | 320 | 50,3 | 19,4 | 26,1 | 29,5 | 485 | | |
| 65078 | 19-24 | 370 | 51,6 | 19,8 | 27,2 | 32,9 | 630 | | |
| 65079 | 24-30 | 420 | 60,5 | 21,4 | 32,3 | 41,1 | 950 | | |
| 65080 | 27-32 | 420 | 60,6 | 21,5 | 37,3 | 42,9 | 950 | | |
| 65081 | 36-41 | 480 | 61,8 | 22,6 | 38,7 | 44,5 | 1710 | | |
| 65082 | 11/16-3/4" | 320 | 42,7 | 18,8 | 24,5 | 26,7 | 485 | 6 | 1 |
| 65083 | 3/4-7/8" | 320 | 50,3 | 19,4 | 26,1 | 29,5 | 485 | | |
| 65084 | 3/4-15/16" | 370 | 51,6 | 19,8 | 27,2 | 32,9 | 630 | | |
| 65085 | 15/16-1.3/16" | 420 | 60,5 | 21,4 | 32,3 | 41,1 | 950 | | |
| 65086 | 1.1/16-1.1/4" | 420 | 60,6 | 21,5 | 37,3 | 42,9 | 950 | | |
| 65087 | 1.7/16-1.5/8" | 480 | 61,8 | 22,5 | 38,7 | 44,5 | 1710 | | |

LLAVES / WRENCHES / CLES / SCHLÜSSEL / CHIAVI / SLEUTELS / CHAVES

LLAVE DE VASO DOBLE CARRACA / DOUBLE RATCHET SOCKET WRENCH / CLE A DOILLES ET DOUBLE CLIQUET
 DOPPELKNARRE / DUBBELDOP RATELSLEUTEL / CHIAVE A BUSSOLA A CRICCO / CHAVE DE CAIXA DUPLA DE ROQUETE

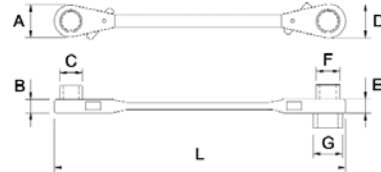

| COD | | L | A | B | C | D | E | F | G | GF | | |
|-------|-------------|-----|------|------|------|------|------|------|------|-----|---|---|
| 65104 | 14-17x19-21 | 275 | 37,8 | 16,7 | 20,1 | 41,9 | 19,4 | 26,4 | 28,5 | 600 | | |
| 65105 | 17-19x22-24 | 330 | 41,5 | 18,7 | 24,1 | 50,8 | 20,4 | 30,2 | 32,4 | 700 | 6 | 1 |
| 65106 | 19-21x24-27 | | 41,7 | 19,7 | 24,3 | 50,9 | 20,6 | 30,4 | 32,5 | 750 | | |

LLAVE ESTRELLA DE CARRACA PLANA / DOUBLE RATCHET WRENCH / CLE POLYGONALE A CLIQUET / DOPPELKNARRE, FLACH
 DUBBELDOP RATELSLEUTEL / CHIAVE A CRICCO / CHAVE LUNETA PLANA COM ROQUETE

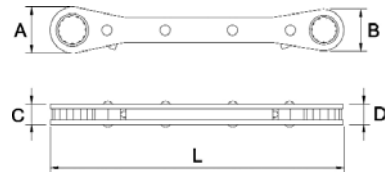

| COD | | L | A | B | C | D | GF | | |
|-------|------------|-----|------|------|------|------|-----|---|---|
| 65107 | 8-10 | 150 | 18,4 | 17,3 | 8,9 | 9,1 | 90 | 6 | 1 |
| 65108 | 10-11 | 175 | 21,8 | 18,7 | 9,1 | 9,6 | 120 | | |
| 65109 | 12-13 | 180 | 26,2 | 21 | 9,5 | 9,7 | 140 | | |
| 65110 | 14-15 | 210 | 32,7 | 30,5 | 10,3 | 9,7 | 200 | | |
| 65111 | 14-17 | 210 | 33,2 | 33,1 | 10,6 | 9,8 | 210 | | |
| 65112 | 19-21 | 230 | 40,2 | 37,5 | 10,7 | 9,8 | 260 | | |
| 65113 | 1/4-5/16" | 150 | 18,4 | 17,8 | 8,6 | 8,6 | 60 | 6 | 1 |
| 65114 | 3/8-7/16" | 175 | 23,8 | 20,3 | 8,9 | 8,6 | 85 | | |
| 65115 | 1/2-9/16" | 180 | 29,2 | 24,2 | 9,8 | 9,7 | 140 | | |
| 65116 | 5/8-11/16" | 210 | 36,2 | 33,2 | 10,3 | 10,4 | 200 | | |
| 65117 | 3/4-7/8" | 210 | 40,1 | 37,4 | 10,7 | 11,7 | 260 | | |

LLAVE ESTRELLA DE CARRACA ACODADA / OFFSET DOUBLE RATCHET WRENCH / CLE POLYGONALE COUDEE A CLIQUET
 DOPPELKNARRE, ABGEWINKELT / GEBOGEN DUBBELE RATELSLEUTEL / CHIAVE A CRICCO A CONTROGOMITO
 CHAVE LUNETA INCLINADA COM ROQUETE

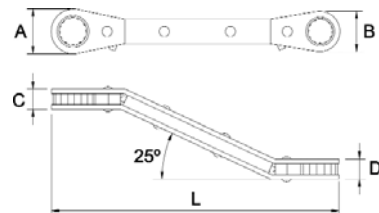

| COD | | L | A | B | C | D | GF | | |
|-------|------------|-----|------|-------|------|------|-----|---|---|
| 65118 | 8-10 | 150 | 20,2 | 18,7 | 9,6 | 8,8 | 85 | 6 | 1 |
| 65119 | 10-11 | 175 | 24,8 | 21,3 | 9,7 | 9,5 | 120 | | |
| 65120 | 12-13 | 180 | 29,3 | 24,3 | 9,8 | 9,7 | 140 | | |
| 65121 | 14-15 | 210 | 36,2 | 33,3 | 9,9 | 9,9 | 200 | | |
| 65122 | 14-17 | 210 | 40,3 | 37,3 | 11,1 | 10,4 | 210 | | |
| 65123 | 19-21 | 230 | 41,2 | 37,5 | 11,3 | 10,5 | 265 | | |
| 65124 | 1/4-5/16" | 150 | 20,1 | 17,2 | 9,3 | 8,7 | 60 | 6 | 1 |
| 65125 | 3/8-7/16" | 175 | 23,3 | 20,3 | 9,4 | 9,2 | 85 | | |
| 65126 | 1/2-9/16" | 180 | 30,1 | 27,5 | 9,8 | 9,4 | 140 | | |
| 65127 | 5/8-11/16" | 210 | 36,4 | 33,33 | 10,2 | 9,6 | 200 | | |
| 65128 | 3/4-7/8" | 210 | 40,3 | 37,5 | 10,4 | 10,2 | 265 | | |

LLAVES DE PIPA ABIERTAS / ANGLED OPEN SOCKETS / CLES A PIPE DEBOUCHEES / PFEIFFENKOPFSCHLÜSSEL
CHIAVI A PIPA APERTE / GEBOGEN PIJPSLEUTEL / DE CACHIMBO ABERTAS

A

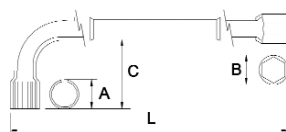

COD

| COD | 6 | L mm | A | B | C | 12x6 | | |
|-------|----|---------|------|------|------|------|---|---|
| 61870 | 6 | 110 | 11 | 11 | 18,5 | 50 | 5 | 1 |
| 61871 | 7 | 114 | 12 | 12 | 21 | 50 | | |
| 61872 | 8 | 119,5 | 13 | 13 | 22 | 60 | | |
| 61873 | 9 | 125 | 14,5 | 14,5 | 22,5 | 70 | | |
| 61874 | 10 | 131 | 16 | 16 | 26 | 100 | | |
| 61875 | 11 | 137 | 17 | 17 | 26,5 | 140 | | |
| 61876 | 12 | 144 | 18 | 18 | 27 | 160 | | |
| 61877 | 13 | 152,5 | 19 | 19 | 30,5 | 170 | | |
| 61878 | 14 | 160 | 21 | 21 | 33,5 | 230 | | |
| 61879 | 15 | 174 | 22,5 | 22,5 | 35 | 230 | | |
| 61880 | 16 | 185 | 24 | 24 | 39,5 | 230 | | |
| 61881 | 17 | 197 | 25 | 25 | 39,5 | 290 | | |
| 61882 | 18 | 211 | 26,5 | 26,5 | 41,5 | 340 | | |
| 61883 | 19 | 218 | 28 | 28 | 44 | 400 | | |
| 61884 | 20 | 222 | 30 | 30 | 45,5 | 470 | | |
| 61885 | 21 | 231 | 30,5 | 30,5 | 48,5 | 520 | | |
| 61886 | 22 | 247 | 32 | 32 | 48,5 | 600 | | |
| 61887 | 23 | 255 | 33,5 | 33,5 | 53 | 700 | | |
| 61888 | 24 | 266 | 34,5 | 34,5 | 55 | 800 | | |
| 61889 | 25 | 278 | 36 | 36 | 57,5 | 1000 | | |
| 61890 | 26 | 289 | 37 | 37 | 58 | 1000 | | |
| 61891 | 27 | 299 | 38,5 | 38,5 | 57 | 1200 | | |
| 61892 | 28 | 310 | 39 | 39 | 59 | 1300 | | |
| 61893 | 29 | 319 | 41 | 41 | 60,5 | 1500 | | |
| 61894 | 30 | 332 | 42 | 42 | 36 | 1500 | | |
| 61895 | 32 | 353 | 45 | 45 | 66,5 | 1500 | | |
| 61768 | 34 | 374 | 48 | 48 | | 1600 | | |
| 61772 | 36 | 395 | 50 | 50 | 67 | 1800 | | |
| 61770 | 38 | 400 | 51,5 | 51,5 | 68 | 2000 | | |

DIN 475

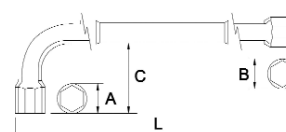

COD

| COD | 6 | L mm | A | B | C | 6x6 | | |
|-------|----|---------|------|------|------|------|---|---|
| 61170 | 6 | 110 | 11 | 11 | 18,5 | 50 | 5 | 1 |
| 61171 | 7 | 114 | 12 | 12 | 21 | 50 | | |
| 61172 | 8 | 119,5 | 13 | 13 | 22 | 60 | | |
| 61173 | 9 | 125 | 14,5 | 14,5 | 22,5 | 70 | | |
| 61174 | 10 | 131 | 16 | 16 | 26 | 100 | | |
| 61175 | 11 | 137 | 17 | 17 | 26,5 | 140 | | |
| 61176 | 12 | 144 | 18 | 18 | 27 | 160 | | |
| 61177 | 13 | 152,5 | 19 | 19 | 30,5 | 170 | | |
| 61178 | 14 | 160 | 21 | 21 | 33,5 | 230 | | |
| 61179 | 15 | 174 | 22,5 | 22,5 | 35 | 230 | | |
| 61180 | 16 | 185 | 24 | 24 | 39,5 | 230 | | |
| 61181 | 17 | 197 | 25 | 25 | 39,5 | 290 | | |
| 61182 | 18 | 211 | 26,5 | 26,5 | 41,5 | 340 | | |
| 61183 | 19 | 218 | 28 | 28 | 44 | 400 | | |
| 61184 | 20 | 222 | 30 | 30 | 45,5 | 470 | | |
| 61185 | 21 | 231 | 30,5 | 30,5 | 48,5 | 520 | | |
| 61186 | 22 | 247 | 32 | 32 | 48,5 | 600 | | |
| 61187 | 23 | 255 | 33,5 | 33,5 | 53 | 700 | | |
| 61188 | 24 | 266 | 34,5 | 34,5 | 55 | 800 | | |
| 61189 | 25 | 278 | 36 | 36 | 57,5 | 1000 | | |
| 61190 | 26 | 289 | 37 | 37 | 58 | 1000 | | |
| 61191 | 27 | 299 | 38,5 | 38,5 | 57 | 1200 | | |
| 61192 | 28 | 310 | 39 | 39 | 59 | 1300 | | |
| 61193 | 29 | 319 | 41 | 41 | 60,5 | 1500 | | |
| 61194 | 30 | 332 | 42 | 42 | 36 | 1500 | | |
| 61195 | 32 | 353 | 45 | 45 | 66,5 | 1500 | | |
| 61769 | 34 | 374 | 48 | 48 | | 1600 | | |
| 61773 | 36 | 395 | 50 | 50 | 67 | 1800 | | |
| 61771 | 38 | 400 | 51,5 | 51,5 | 68 | 2000 | | |

A cromado pulido espejo / mirror polished chrome plating / polie chromée / poliert verchromt
cromate lucide / gepolijst en verchromd / cromado polido



7

LLAVES / WRENCHES / CLES / SCHLÜSSEL / CHIAVI / SLEUTELS / CHAVES

KIT-10 PCS.

| COD | | |
|-------|-----------------------------|------|
| 69351 | 8-9-10-11-12-13-14-17-19-21 | 12X6 |
| 69353 | 8-9-10-11-12-13-14-17-19-21 | 6X6 |



DE TUBO DOBLE BOCA / SOCKET DOUBLE ENDED / ATUBE DROITE FORGEE / DOPPEL-STECKSCHLÜSSEL / CHIAVI A TUBO DIRITTE
RECHTE PIJPSLEUTEL / TUBOLARES BOCA DUPLA

TITACROM®



| COD | | L | A | B | UF | | |
|-------|-------|-----|----|----|-----|----|---|
| 61824 | 6-7 | 105 | 10 | 11 | 30 | 10 | 1 |
| 61825 | 8-9 | 110 | 13 | 14 | 50 | | |
| 61826 | 10-11 | 120 | 15 | 16 | 80 | | |
| 61827 | 12-13 | 140 | 18 | 19 | 140 | | |
| 61828 | 14-15 | 145 | 20 | 22 | 155 | | |
| 61829 | 16-17 | 155 | 23 | 24 | 180 | | |
| 61830 | 18-19 | 165 | 25 | 26 | 230 | | |
| 61831 | 20-22 | 170 | 28 | 30 | 290 | | |
| 61832 | 21-23 | 185 | 29 | 31 | 340 | | |
| 61833 | 24-26 | 190 | 33 | 33 | 430 | | |
| 61838 | 24-27 | 190 | 33 | 35 | 435 | 6 | |
| 61834 | 25-28 | 205 | 34 | 37 | 510 | | |
| 61835 | 27-29 | 210 | 37 | 39 | 560 | | |
| 61836 | 30-32 | 210 | 40 | 42 | 725 | | |

DIN 896A

LLAVE DE CREMALLERA / AUTO WRENCH / CLE A CREMALLIERE / VERSTELLBARE ROHRZANGE / CHIAVE A CREMAGLIERA
VERSTELBARE "MOERSLEUTEL" / CHAVE DE CREMALHEIRA

TITACROM®

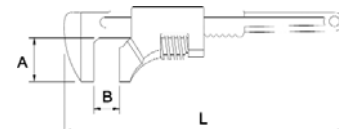

| COD | | L | A | B | UF | | |
|-------|-----|------|------|------|----|---|--|
| 61360 | 9" | 65mm | 33mm | 500 | 5 | 1 | |
| 61361 | 11" | 80mm | 45mm | 830 | | | |
| 61362 | 15" | 85mm | 45mm | 1545 | | | |

DE VASO DOBLE ARTICULACION / DOUBLE ENDED SWIVEL / CLES A DOILLES ARTICULEES / DOPPEL-GELENKSTECKSCHLÜSSEL
 CHIAVE A BUSSOLA DOPPA SNODABILE / KNIESLEUTEL / DE CAIXA ARTICULADAS

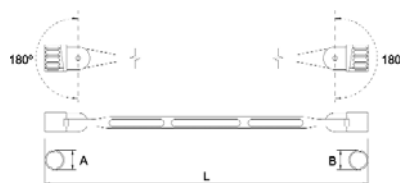

| COD | | L | A | B | IP | | |
|-------|-------|-----|------|------|-----|----|---|
| 61301 | 8-9 | 160 | 12,3 | 12,9 | 100 | 10 | 1 |
| 61302 | 10-11 | 165 | 14,9 | 15,8 | 110 | | |
| 61303 | 12-13 | 170 | 18,7 | 18,9 | 155 | | |
| 61304 | 14-15 | 180 | 20,8 | 20,8 | 200 | | |
| 61305 | 16-17 | 190 | 22,8 | 23,7 | 285 | | |
| 61306 | 18-19 | 205 | 25,8 | 25,8 | 390 | 5 | |
| 61308 | 20-22 | 215 | 27,8 | 29,9 | 485 | | |
| 61309 | 21-23 | 215 | 31,6 | 31,6 | 475 | | |
| 61310 | 24-27 | 285 | 31,7 | 35,7 | 700 | | |

KIT-6

| COD | C | Kg | |
|-------|--|-----|---|
| 69185 | 8-9, 10-11, 12-13, 14-15, 16-17, 18-19 | 1,6 | 1 |



DE BUJIA ARTICULADA / SPARK PLUG WRENCH / CLES A BOUGIE ART. / ZÜNDKERZENSCHLÜSSEL
 CHIAVI PER CANDELE SNODABILE / ONTSTEKINGSKAARS / CHAVE ARTICULADA PARA VELAS

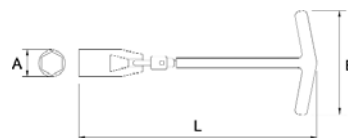

| COD | | L | A | B | IP | | |
|-------|-------------|-----|------|------|-----|---|---|
| 61471 | 20,6-13/16" | 229 | 27,9 | 99,4 | 250 | 5 | 1 |

DIN 3112

EXTENSIBLE PARA RUEDAS / EXTENSIBLE WHEEL WRENCH / CLES A ROUES EXTENSIBLE / AUSZIEHBARER RADMUTTERNSCHLÜSSEL
 CHIAVE ESTENSIBILE PER RUOTE / VERLENGBARE WIELSLEUTEL / EXTENSÍVEL PARA RODAS

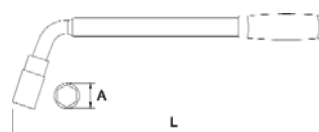

| COD | | L mm | A | IP | |
|-------|-------|------|------|-----|---|
| 61476 | 17-19 | 550 | 27,6 | 780 | 3 |

DIN 3112

LLAVES / WRENCHES / CLES / SCHLÜSSEL / CHIAVI / SLEUTELS / CHAVES

LLAVES ARTICULADAS EN T / T-HANDLE WRENCHES WITH UNIVERSAL JOINT / CLE A BEQUILLE ARTICULEE / KARDAN GELENKSCHLÜSSEL / CHIAVE A T CON SNODO CARDANICO / STRIPTANG / CHAVES T COM CARDAN

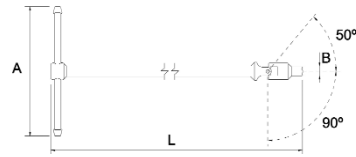

| COD | mm | L | A | B | mm | mm | mm |
|-------|----|-----|-----|------|-----|----|----|
| 61840 | 6 | 390 | 165 | 10,5 | 225 | 1 | 1 |
| 61841 | 7 | | | 11,5 | | | |
| 61842 | 8 | | | 12 | | | |
| 61843 | 9 | | | 14 | | | |
| 61844 | 10 | | | 15 | | | |
| 61845 | 11 | 450 | 180 | 17 | 425 | 1 | 1 |
| 61846 | 12 | | | 18 | | | |
| 61847 | 13 | | | 19 | | | |
| 61848 | 14 | | | 20,5 | | | |
| 61849 | 15 | | | 22 | | | |
| 61850 | 16 | 500 | 180 | 23 | 480 | 1 | 1 |
| 61851 | 17 | | | 24 | | | |
| 61852 | 18 | | | 25 | | | |
| 61853 | 19 | | | 27 | | | |
| 61854 | 20 | | | 28 | | | |
| 61855 | 21 | 510 | 230 | 29 | 860 | 1 | 1 |
| 61856 | 22 | | | 31 | | | |
| 61857 | 23 | | | 32 | | | |
| 61858 | 24 | | | 33 | | | |

EN CRUZ PLEGABLE / FOLDING CROSS RIM WRENCH / CLE EN CROIX PLIABLE / KREUZSCHLÜSSEL, KLAPPBAR / CHIAVE A CROCE PIEGABILE / PLOOIBARE VELGSLEUTEL / CHAVE EM CRUZ DOBRAVEL

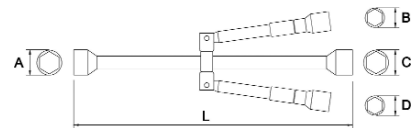

| COD | mm | L | A | B | C | D | mm | mm |
|-------|-------------|-----|----|----|----|----|------|----|
| 61477 | 17-19-21-23 | 355 | 30 | 26 | 32 | 28 | 1285 | 1 |

DIN 3119

EN CRUZ / CROSS RIM WRENCH / CLE EN CROIX / KREUZSCHLÜSSEL / CHIAVE A CROCE / KRUISVELGSLEUTEL / CHAVE DE CRUZETA

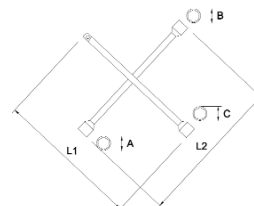

| COD | mm | L1 | L2 | A | B | C | mm | mm |
|-------|----------------|-----|-----|----|----|----|------|----|
| 61475 | 17-19-22- 1/2" | 355 | 355 | 28 | 26 | 31 | 1150 | 1 |

DIN 3119

**LLAVES HEXAGONALES / HEXAGONAL KEYS / CLES MALES / INBUSSCHLÜSSEL
 CHIAVI ESAGONALI / INBUSSLEUTELS / CHAVES HEXAGONAIS**

STANDARD

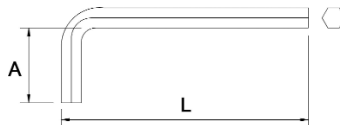

| COD | | | | | | |
|-------|-------|------|------|-------|----|---|
| 65302 | 0,9mm | 32,9 | 10 | 0,25 | | |
| 61501 | 1,5mm | 45 | 14 | 1 | | |
| 61502 | 2mm | 50 | 16 | 2 | | |
| 61503 | 2,5mm | 56 | 18 | 3 | | |
| 61504 | 3mm | 63 | 20 | 5 | | |
| 65303 | 3,5mm | 68 | 26,5 | 7,5 | | |
| 61505 | 4mm | 70 | 25 | 10 | | |
| 65304 | 4,5mm | 79,5 | 27 | 14 | | |
| 61506 | 5mm | 80 | 28 | 15 | | |
| 61507 | 5,5mm | 85 | 30 | 25 | | |
| 61508 | 6mm | 90 | 32 | 30 | | |
| 61509 | 8mm | 100 | 36 | 60 | 10 | 1 |
| 65305 | 9mm | 115 | 38 | 81 | | |
| 61510 | 10mm | 112 | 40 | 105 | | |
| 65306 | 11mm | 128 | 43 | 137,5 | | |
| 65307 | 12mm | 137 | 45 | 170 | | |
| 65308 | 14mm | 154 | 56 | 265 | | |
| 65309 | 16mm | 166 | 60 | 370 | | |
| 65310 | 17mm | 177 | 63 | 442 | | |
| 65311 | 19mm | 199 | 70 | 631 | | |
| 65312 | 21mm | 205 | 75 | 790 | | |
| 65313 | 22mm | 222 | 80 | 940 | | |
| 65314 | 24mm | 248 | 90 | 1253 | | |

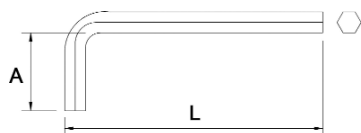





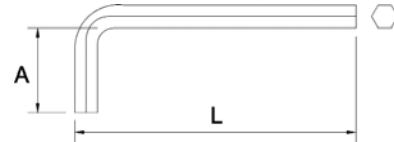

| COD | | | | | | |
|-------|-------|-------|----|-----|----|---|
| 65315 | 1/16" | 45,6 | 14 | 0,9 | | |
| 65316 | 5/64" | 50 | 15 | 1,7 | | |
| 65317 | 3/32" | 53,4 | 17 | 2 | | |
| 65318 | 1/8" | 60,2 | 19 | 5 | | |
| 65319 | 5/32" | 68 | 21 | 9 | | |
| 65320 | 3/16" | 74,8 | 24 | 14 | | |
| 65321 | 7/32" | 81,6 | 26 | 21 | | |
| 65322 | 1/4" | 89,4 | 28 | 31 | 10 | 1 |
| 65323 | 5/16" | 102,9 | 32 | 55 | | |
| 65324 | 3/8" | 117,5 | 35 | 90 | | |
| 65325 | 7/16" | 132 | 38 | 136 | | |
| 65326 | 1/2" | 145,7 | 41 | 196 | | |
| 65327 | 9/16" | 160,3 | 44 | 271 | | |
| 65328 | 5/8" | 174,9 | 48 | 365 | | |
| 65329 | 3/4" | 203,1 | 54 | 604 | | |

Cr-V DIN 2936

LLAVES HEXAGONALES / HEXAGONAL KEYS / CLES MALES / INBUSSCHLÜSSEL
CHIAVI ESAGONALI / INBUSSLEUTELS / CHAVES HEXAGONAIS







SERIE LARGA / LONG PATTERN / SERIE LONGUE / LANGE SCHENKEL / SERIE LUNGA / VERLENGD MODEL / SERIE LONGA

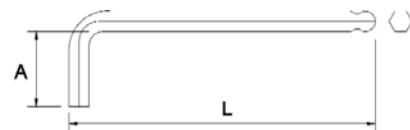

| COD |  |  |  |  |  |  |
|-------|---|---|---|---|---|---|
| 61517 | 1,5mm | 77 | 14 | 1 | | |
| 61518 | 2mm | 83 | 16 | 2 | | |
| 61519 | 2,5mm | 90 | 18 | 4 | | |
| 61520 | 3mm | 98 | 20 | 7 | | |
| 61521 | 4mm | 106 | 25 | 15 | | |
| 61522 | 5mm | 118 | 28 | 25 | | |
| 61523 | 5,5mm | 128 | 30 | 35 | 10 | 1 |
| 61524 | 6mm | 137 | 32 | 40 | | |
| 61525 | 8mm | 156 | 36 | 80 | | |
| 65330 | 9mm | 174 | 38 | 114,3 | | |
| 61526 | 10mm | 170 | 40 | 140 | | |
| 65331 | 11mm | 199 | 42 | 200 | | |
| 65332 | 12mm | 234 | 45 | 257,6 | | |

Cr-V DIN 2936

BOLA SERIE LARGA / LONG PATTERN BALLPOINT / LONGUE A TETE SPHERIQUE / KUGELKOPF- INBUSSCHLÜSSEL
SERIE LUNGA CON TESTA SFERICA / INBUSSLEUTEL MET BOLLE KOP / ESFERICAS, SERIE LONGA

| COD |  |  |  |  |  |  |
|-------|---|---|---|---|---|---|
| 61615 | 1,5 | 83 | 14 | 1 | | |
| 61616 | 2 | 90 | 16 | 2 | | |
| 61617 | 2,5 | 98 | 18 | 3 | | |
| 61618 | 3 | 107 | 20 | 5 | | |
| 61619 | 4 | 117 | 25 | 10 | | |
| 61620 | 5 | 128 | 28 | 15 | 10 | 1 |
| 61621 | 5,5 | 140 | 32 | 25 | | |
| 61622 | 6 | 152 | 36 | 30 | | |
| 61623 | 8 | 170 | 40 | 60 | | |
| 61624 | 10 | 183 | 45 | 140 | | |

Cr-V DIN 2936

**LLAVES TORX / TORX KEYS / CLES TORX / TORX INBUSSCHLÜSSEL / CHIAVI TORX
TORX INBUSSLEUTELS / CHAVES TORX**

TORX

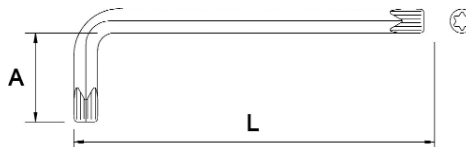

| COD | | | | | | |
|-------|------|------|----|-----|----|---|
| 65333 | T-10 | 49 | 16 | 3,5 | 10 | 1 |
| 65334 | T-15 | 56,5 | 17 | 5 | | |
| 65335 | T-20 | 62 | 19 | 7,5 | | |
| 65336 | T-25 | 69,5 | 20 | 9,5 | | |
| 65337 | T-27 | 77 | 24 | 15 | | |
| 65338 | T-30 | 86 | 29 | 20 | | |
| 65339 | T-40 | 97 | 34 | 32 | | |
| 65340 | T-45 | 110 | 39 | 44 | | |
| 65341 | T-50 | 124 | 41 | 63 | | |

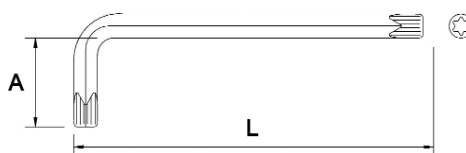
**TORX
SERIE LARGA / LONG PATTERN / SERIE LONGUE / LANGE SCHENKEL / SERIE LUNGA / VERLENGD MODEL / SERIE LONGA**

| COD | | | | | | |
|-------|------|-------|----|------|----|---|
| 65342 | T-10 | 89 | 17 | 6 | 10 | 1 |
| 65343 | T-15 | 93,5 | 17 | 9,1 | | |
| 65344 | T-20 | 99 | 19 | 12,2 | | |
| 65345 | T-25 | 104,5 | 20 | 16 | | |
| 65346 | T-27 | 110 | 21 | 24 | | |
| 65347 | T-30 | 120 | 24 | 31 | | |
| 65348 | T-40 | 131 | 26 | 46 | | |
| 65349 | T-45 | 141 | 28 | 64 | | |
| 65350 | T-50 | 161 | 32 | 91 | | |

EGA *Master* S.A.
ART IN INNOVATION

JUEGOS / SETS / ASSORTIMENTS / SÄTZE / ASSORTIMENTI / JOGOS

| COD | PCS. | | | | | |
|-------|------|----|---|-----|----|---|
| 61499 | 8 | | 1,5-2-2,5-3-4-5-5,5-6 | 105 | | |
| 61500 | A | 10 | 1,5-2-2,5-3-4-5-5,5-6-8-10 | 270 | 12 | 1 |
| 61516 | | | 1/16"-5/64"-3/32"-1/8"-5/32" 3/16"-7/32"-1/4"-5/16"-3/8" | | | |
| 61512 | B | 7 | 2,5-3-4-5-6-8-10 | 335 | | |
| 61496 | C | 10 | 1,5-2-2,5-3-4-5-5,5-6-8-10 | 360 | | |
| 61495 | | | 1/16"-5/64"-3/32"-1/8"-5/32" 3/16"-7/32"-1/4"-5/16"-3/8" | | | |

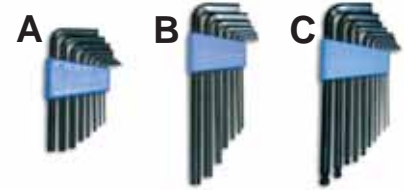

| COD | PCS. | | | | | |
|-------|------|---|-------------------------------------|-----|----|---|
| 65351 | D | 9 | T10-T15-T20-T25-T27-T30-T40-T45-T50 | 250 | 12 | 1 |

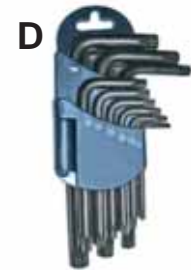

| COD | PCS. | | | | | |
|-------|------|--|---|-------------------------|-----|----|
| 61511 | A | | 8 | 2,5-3-4-5-6-7-8-10 | 330 | |
| 61514 | B | | 6 | 2,5-3-4-5-6-8 | 175 | 12 |
| 61513 | C | | 6 | T10-T15-T20-T25-T27-T30 | 125 | 1 |

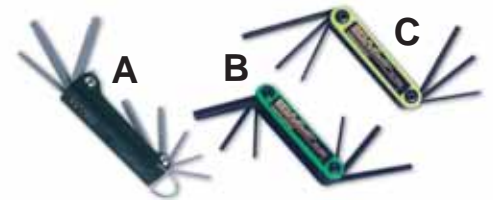

| COD | PCS. | | | | | |
|-------|------|--|---|--|-----|----|
| 65352 | A | | 8 | 1,5-2-2,5-3-4-5-6-8 | 140 | |
| 65353 | B | | 8 | 5/64-3/32-1/8--5/32-3/16- 7/32-1/4-5/16 | 150 | 12 |
| 65354 | C | | 8 | T9-T10-T15-T20-T25-T27-T30-T40 | 140 | 1 |





**LLAVES DE VASO / SOCKET WRENCHES / DOUILLES / STECKSCHLÜSSEL / BUSSOLE
DOPPEN / CHAVES DE CAIXA**

1/4"

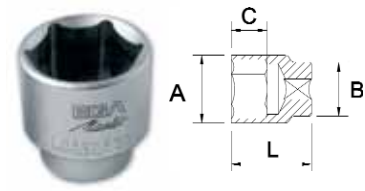
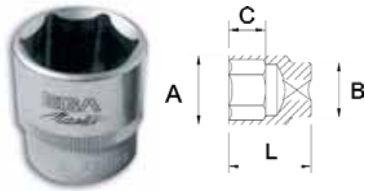

MM

| COD X | L | A | B | C | | | |
|-------|------|------|------|-----|----|----|---|
| 61311 | 4mm | 6,9 | | 2 | | | |
| 61312 | 5mm | 8,1 | 12 | 2,5 | 10 | | |
| 61313 | 6mm | 9,4 | | 3,5 | | | |
| 61314 | 7mm | 10,8 | | 3,5 | 12 | | |
| 61315 | 8mm | 12 | 11 | 4 | | | |
| 61316 | 9mm | 13 | 11,5 | 5 | 14 | 10 | 1 |
| 61317 | 10mm | 14 | 12,5 | 6 | 18 | | |
| 61318 | 11mm | 16 | 13,6 | 7 | 22 | | |
| 61319 | 12mm | 17 | 14,6 | 8 | 24 | | |
| 61320 | 13mm | 18 | 16 | 8 | 25 | | |
| 61321 | 14mm | 20 | 17,5 | 10 | 30 | | |

Cr-V DIN 3124

INCH.

| COD y | L | A | B | C | | | |
|-------|--------|------|------|-----|----|----|---|
| 60420 | 5/32" | 6,9 | | 2 | | | |
| 60421 | 3/16" | 8,1 | 12 | 2,5 | 10 | | |
| 60422 | 7/32" | 8,8 | | 3 | | | |
| 60423 | 1/4" | 9,9 | | 3,5 | 12 | | |
| 60424 | 9/32" | 10,8 | 11 | 4 | | | |
| 60425 | 5/16" | 12 | 11,5 | 5 | 14 | 10 | 1 |
| 60426 | 11/32" | 13 | 12,5 | 6 | 18 | | |
| 60427 | 3/8" | 14 | 13,6 | 7 | 22 | | |
| 60428 | 7/16" | 16 | 14,6 | 8 | 24 | | |
| 60429 | 1/2" | 18 | 16 | 8 | 25 | | |
| 60430 | 9/16" | 20 | 17,5 | 10 | 30 | | |

Cr-V DIN 3124

DESTORNILLADOR PORTAVASOS 1/4" / 1/4" SOCKET HOLDER / TOURNEVIS PORTE-DOUILLE 1/4" / 1/4" SOCKET HALTER
CACCIAVITE PORTA BUSSOLA 1/4" / 1/4" DOPSLEUTEL HOUDER / APARAFUSADOR PORTA CHAVES CAIXA 1/4"

| COD | L | A | B | C | | | |
|-------|------|-----|---|----|---|--|---|
| 66732 | 1/4" | 190 | | 95 | 6 | | 1 |



LLAVE DE CARRACA REVERSIBLE / REVERSIBLE RATCHET HANDLE / CLE A CLIQUET / UMSCHALTKNARRE
CHIAVE A CRICCO REVERSIBLE / RATEL MET OMKEERMECHANISME / ROQUETE REVERSIVEL

| COD | L | A | B | C | | | |
|-------|------|-----|---|---|--|--|---|
| 61428 | 1/4" | 105 | | 6 | | | 1 |

DIN 3122



MANGO CORREDIZO EN "T" / SLIDING "T" HANDLE / POIGNEE COULISSANTE / QUERGRIF / ASTA CON QUADRO SCORREVOLO
"T" WRINGSTAAF / CABO "T" CORREDIÇO

| COD | L | A | B | C | | | |
|-------|------|----|---|---|--|--|---|
| 61438 | 1/4" | 60 | | 5 | | | 1 |

DIN 3122



ARTICULACION UNIVERSAL / UNIVERSAL JOINT / CARDAN UNIVERSEL / KARDANGELENK / SNODO CARDANICO
DOP MET CARDANGEWIRICH / CARDAN UNIVERSAL

| COD | L | A | B | C | | | |
|-------|------|----|---|----|--|--|---|
| 61435 | 1/4" | 30 | | 10 | | | 1 |

DIN 3123



ALARGADERA / EXTENSION / RALLONGE / VERLÄNGERUNG / PROLUNGA / VERLENGSTUK / EXTENÇÃO

| COD | L | A | B | C | | | |
|-------|----|----|---|---|--|--|---|
| 61442 | 2" | 25 | | 5 | | | 1 |
| 61444 | 6" | 65 | | | | | |

DIN 3123



- x 50% cromado aeroespacial / 50% aerospaceal chrome plating / 50% chromée aérospatiale
50% cromado pulido espejo / 50% mirror polished chrome plating / 50% polie chromée
- y 100% cromado pulido espejo / 100% mirror polished chrome plating / 100% polie chromée

3/8"



MM

| COD X | Size | L | A | B | C | Weight | Material |
|-------|------|------|------|----|----|--------|------------------|
| 61343 | 8mm | 12,2 | | | 5 | 20 | Cr-V DIN 3124 |
| 61344 | 9mm | 13,5 | 17 | | 6 | 26 | |
| 61345 | 10mm | 14,7 | | | | | |
| 61346 | 11mm | 16 | | 7 | 28 | | |
| 61347 | 12mm | 17 | 16 | 8 | | | |
| 61348 | 13mm | 18 | 16,5 | | 10 | 30 | |
| 61349 | 14mm | 20 | 18 | 12 | | | |
| 61350 | 15mm | 21 | 20 | | 14 | 60 | |
| 61351 | 16mm | 22 | 20 | 16 | | | |
| 61352 | 17mm | 24 | 21 | | 18 | | |
| 61353 | 18mm | 24 | 22 | 20 | | | |
| 61354 | 19mm | 26 | 22 | | 22 | | |
| 61355 | 20mm | 27 | 24 | 24 | | | |
| 61356 | 21mm | 28 | 24 | | 26 | | |
| 61357 | 22mm | 30 | 26 | 28 | | | |

INCH.

| COD y | Size | L | A | B | C | Weight | Material |
|-------|--------|------|------|----|----|--------|------------------|
| 60439 | 1/4" | 12 | | | 5 | 20 | Cr-V DIN 3124 |
| 60440 | 5/16" | 12,2 | 17 | | 6 | 26 | |
| 60441 | 11/32" | 13,5 | | | | | |
| 60442 | 3/8" | 14,7 | | 7 | 28 | | |
| 60443 | 7/16" | 16 | 16 | 8 | | | |
| 60444 | 1/2" | 18 | 16,5 | | 10 | 30 | |
| 60445 | 9/16" | 20 | 18 | 12 | | | |
| 60446 | 19/32" | 21 | 20 | | 14 | 60 | |
| 60447 | 5/8" | 22 | 20 | 16 | | | |
| 60448 | 11/16" | 24 | 21 | | 18 | | |
| 60449 | 3/4" | 26 | 22 | 20 | | | |
| 60450 | 13/16" | 28 | 24 | | 22 | | |
| 60451 | 7/8" | 30 | 26 | 24 | | | |

LLAVE DE CARRACA REVERSIBLE / REVERSIBLE RATCHET HANDLE / CLE A CLIQUET / UMSCHALTKNARRE
CHIAVE A CRICCO REVERSIBLE / RATEL MET OMKEERMECHANISME / ROQUETE REVERSIVEL

| COD | Size | L | Weight | Material |
|-------|------|-----|--------|---------------|
| 61429 | 3/8" | 270 | 6 | 1 DIN 3122 |



MANGO CORREDIZO EN "T" / SLIDING "T" HANDLE / POIGNEE COULISSANTE / QUERGRIF / ASTA CON QUADRO SCORREVOLO
"T" WRINGSTAAF / CABO "T" CORREDIÇO

| COD | Size | L | Weight | Material |
|-------|------|-----|--------|---------------|
| 61439 | 3/8" | 180 | 5 | 1 DIN 3122 |



ARTICULACION UNIVERSAL / UNIVERSAL JOINT / CARDAN UNIVERSEL / KARDANGELENK / SNODO CARDANICO DOP MET CAR-
DANGEWRIICH / CARDAN UNIVERSAL

| COD | Size | L | Weight | Material |
|-------|------|----|--------|---------------|
| 61436 | 3/8" | 80 | 10 | 1 DIN 3123 |



ALARGADERA / EXTENSION / RALLONGE / VERLÄNGERUNG / PROLUNGA / VERLENGSTUK / EXTENÇÃO

| COD | Size | L | Weight | Material |
|-------|------|-----|--------|---------------|
| 61447 | 5" | 120 | 5 | 1 DIN 3123 |
| 61450 | 10" | 240 | | |



- x 50% cromado aeroespacial / 50% aerospaceal chrome plating / 50% chromée aérospatiale
50% cromado pulido espejo / 50% mirror polished chrome plating / 50% polie chromée
- y 100% cromado pulido espejo / 100% mirror polished chrome plating / 100% polie chromée

1/2"

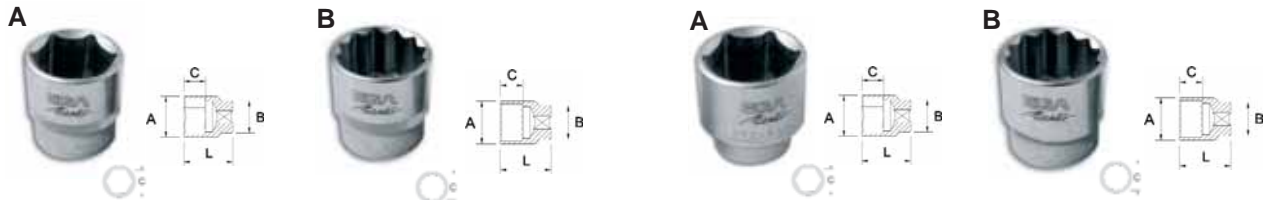

MM

| COD X | | COD X | | COD X | | | | | |
|-------|-------|-------|------|-------|-------|-------|----|-------|-----|
| A | B | A | B | A | B | | | | |
| 40 | 61800 | 8mm | 13 | 5 | 61380 | 45 | | | |
| 45 | 61801 | 9mm | 14 | | 61381 | | | | |
| | 61802 | 10mm | 15,5 | 6 | 61382 | | | | |
| 50 | 61803 | 11mm | 16,7 | 22 | 7 | 61383 | | | |
| | 61804 | 12mm | 18 | | 8 | 61384 | 50 | | |
| | 61805 | 13mm | 19,2 | | | 61385 | | | |
| 10 | 55 | 61806 | 14mm | 20,5 | | 61386 | 10 | | |
| | | 61807 | 15mm | | 10 | 61387 | 55 | | |
| | | 61808 | 16mm | 38 | 22 | 20,8 | 10 | 61388 | |
| | 70 | 61809 | 17mm | 24 | 22 | | | 61389 | 60 |
| | 90 | 61810 | 18mm | 26 | 23,2 | | | 61390 | 80 |
| | 80 | 61811 | 19mm | | | 12 | | 61391 | 60 |
| | 95 | 61812 | 20mm | 28 | 24 | | | 61392 | 80 |
| | 90 | 61813 | 21mm | | | | | 61393 | 75 |
| | 110 | 61814 | 22mm | 30 | | 14 | | 61394 | 85 |
| | 105 | 61815 | 23mm | 32 | 25 | | | 61395 | 105 |
| | 95 | 61816 | 24mm | | | | | 61396 | |
| | 125 | 61817 | 25mm | 42 | 34 | 27 | 16 | 61397 | 130 |
| 5 | 135 | 61818 | 26mm | | | | | 61398 | 140 |
| | 145 | 61819 | 27mm | | 36 | 28 | 18 | 61399 | 150 |
| | 155 | 61820 | 28mm | | 38 | 30 | | 61400 | 160 |
| | 160 | 61821 | 29mm | 45 | | | 20 | 61401 | 170 |
| | 165 | 61822 | 30mm | | 40 | 31 | | 61402 | 190 |
| | 180 | 61823 | 32mm | | 42 | 33 | 22 | 61403 | 205 |

Cr-V DIN 3124

INCH.

| COD y | | COD y | | COD y | | | | | |
|-------|-------|-------|---------|-------|-------|-------|-------|-------|-----|
| A | B | A | B | A | B | | | | |
| 40 | 60460 | 5/16" | 15,3 | 5 | 60480 | 40 | | | |
| 45 | 60461 | 3/8" | 14 | 6 | 60481 | 45 | | | |
| | 60462 | 7/16" | 16,7 | 7 | 60482 | 50 | | | |
| 50 | 60463 | 1/2" | 19,2 | 22 | 8 | 60483 | | | |
| | 60464 | 9/16" | 20,5 | | | 60484 | | | |
| 10 | 55 | 60465 | 19/32" | 22 | 10 | 60485 | 55 | | |
| | | 60466 | 5/8" | | | 60486 | 10 | | |
| | 70 | 60459 | 21/32" | 38 | 23 | 23 | 11 | 60479 | 60 |
| | | 60467 | 11/16" | | 24 | 24 | | 60487 | 70 |
| | 80 | 60468 | 3/4" | 26 | 23,2 | | 12 | 60488 | 80 |
| | 95 | 60469 | 25/32" | | 26 | 24 | | 60489 | 95 |
| | | 60470 | 13/16" | 28 | 24 | | | 60490 | |
| | 110 | 60471 | 7/8" | 30 | | 14 | 60491 | 110 | |
| | 115 | 60472 | 15/16" | 32 | 25 | | | 60492 | 115 |
| | 125 | 60473 | 31/32" | | 32 | | 16 | 60493 | 125 |
| | 135 | 60474 | 1" | 34 | 27 | | | 60494 | 135 |
| 5 | 145 | 60475 | 1.1/16" | 42 | 36 | 28 | 18 | 60495 | 145 |
| | 155 | 60476 | 1.1/8" | | 38 | 30 | 20 | 60496 | 155 |
| | 165 | 60477 | 1.3/16" | 45 | 40 | 31 | | 60497 | 165 |
| | 180 | 60478 | 1.1/4" | | 42 | | 22 | 60498 | 180 |

Cr-V DIN 3124

1/2" SERIE LARGA / LONG SERIE / SERIE LONGUE / LANGE SERIE / SERIE LUNGA
LANGE SERIE / SERIE LONGA



MM

| COD X | | COD X | | COD X | |
|-------|------|-------|------|-------|-----|
| A | B | A | B | A | B |
| 65044 | 10mm | 15,5 | 9 | | |
| 65045 | 11mm | 16,7 | 10,5 | | |
| 65046 | 12mm | 18 | | | |
| 65047 | 13mm | 19,2 | 12 | | 90 |
| 65048 | 14mm | 20,5 | | | |
| 65049 | 15mm | | | | |
| 65050 | 16mm | 22 | 15 | | |
| 65051 | 17mm | 24 | | | 10 |
| 65052 | 18mm | | | | 100 |
| 65053 | 19mm | 26 | | | 135 |
| 65054 | 21mm | | 18 | | 175 |
| 65055 | 22mm | 28 | | | 200 |
| 65056 | 23mm | | 21 | | 210 |
| 65057 | 24mm | 32 | 24 | | 220 |

Cr-V DIN 3124

INCH.

| COD y | | COD y | | COD y | | | |
|-------|--------|-------|----|-------|-----|----|---|
| A | B | A | B | A | B | | |
| 65064 | 3/8" | 14 | 6 | | | | |
| 65065 | 7/16" | 16,7 | 7 | | | | |
| 65066 | 1/2" | 19,2 | 8 | | 90 | | |
| 65067 | 9/16" | 20,5 | 10 | | | | |
| 65068 | 5/8" | | | | | | |
| 65069 | 11/16" | 76 | 22 | 15 | 100 | 10 | 1 |
| 65070 | 3/4" | | 24 | | 135 | | |
| 65071 | 13/16" | | | 18 | 175 | | |
| 65072 | 7/8" | | 26 | 21 | 200 | | |
| 65073 | 15/16" | | 28 | 24 | 220 | | |

Cr-V DIN 3124

- x 50% cromado aeroespacial / 50% aerospace chrome plating / 50% chromée aérospatiale
50% cromado pulido espejo / 50% mirror polished chrome plating / 50% polie chromée
- y 100% cromado pulido espejo / 100% mirror polished chrome plating / 100% polie chromée

MANGO ARTICULADO / FLEXIBLE HANDLE / MANCHE ARTICULÉ / FLEXIBLE VERBINDUNG / IMPUGNATURA SNODABILE / FLEXIBEL VERBINDING / CABO ARTICULADO

| COD | | | | |
|-------|------|----------|----|-----|
| 61441 | 1/2" | 0 - 180° | 15 | 650 |



NEW

MANGO ARTICULADO DE ACCION RAPIDA / QUICK RELEASE FLEXIBLE HANDLE / MANCHE ARTICULÉ ACTION RAPIDE / FLEXIBLE VERBINDUNG MIT SCHNELLVERSTELLUNG / MANICO SNODABILE AZIONE RAPIDA / SNELVERSTELBARE FLEXIBEL VERBINDING CABO ARTICULADO DE ACÇÃO RÁPIDA

| COD | | | | |
|-------|------|-----|-----|---|
| 61483 | 1/2" | 432 | 900 | 6 |



NEW

MANGO ARTICULADO TELESCOPICO / TELESCOPIC FLEXIBLE HANDLE / MANCHE ARTICULÉ TÉLESCOPIQUE / TELESKOPISCHE FLEXIBLE VERBINDUNG / MANICO SNODABILE FLESSIBILE / TELESCOPISCHE FLEXIBELE VERBINDING / CABO ARTICULADO TELESCÓPICO

| COD | | | | | |
|-------|------|-----|-----|------|---|
| 61484 | 1/2" | 430 | 640 | 1150 | 6 |



NEW

ALARGADERA / EXTENSION / RALLONGE / VERLÄNGERUNG / PROLUNGA / VERLENGSTUK / EXTENÇÃO

| COD | 1/2" | | | |
|-------|------|-----|---|---|
| 61453 | 3" | 135 | 5 | 1 |
| 61455 | 5" | 225 | | |
| 61458 | 10" | 375 | | |

DIN 3123



BERBIQUÍ / SPEEDER HANDLE / VILLEBREQUIN / KURBEL / LEVA GIROBECCHINO / OMSLAG / MANIVELA

| COD | | | | |
|-------|------|-----|---|---|
| 61434 | 1/2" | 570 | 5 | 1 |

DIN 3122



LLAVE DE CARRACA REVERSIBLE / REVERSIBLE RATCHET HANDLE / CLE A CLIQUET / UMSCHALTKNARRE
CHIAVE A CRICCO REVERSIBLE / RATEL MET OMKEERMECHANISME / ROQUETE REVERSIVEL

| COD | | | | |
|-------|------|-----|---|---|
| 61430 | 1/2" | 575 | 6 | 1 |

DIN 3122



GEARLESS - CARRACA A FRICCIÓN

| COD | | | | |
|-------|------|-----|---|---|
| 61431 | 1/2" | 560 | 6 | 1 |

DIN 3122



MANGO CORREDIZO EN "T" / SLIDING "T" HANDLE / POIGNEE COULISSANTE / QUERGRIF / ASTA CON QUADRO SCORREVOLO
"T" WRINGSTAAF / CABO "T" CORREDIÇO

| COD | | | | |
|-------|------|-----|---|---|
| 61440 | 1/2" | 160 | 5 | 1 |

DIN 3122



ARTICULACION UNIVERSAL / UNIVERSAL JOINT / CARDAN UNIVERSEL / KARDANGELENK / SNODO CARDANICO / DOP MET CARDANGEWRIJ / CARDAN UNIVERSAL

| COD | | | | |
|-------|------|-----|----|---|
| 61437 | 1/2" | 140 | 10 | 1 |

DIN 3123



3/4"

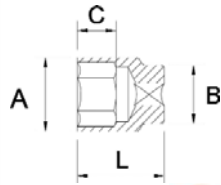

MM

| COD X | L | A | B | C | | | |
|-------|------|----|-------|----|----|------|------|
| 60501 | 19mm | | 29,20 | 33 | | 185 | |
| 60503 | 22mm | 50 | 32,20 | | 14 | 210 | |
| 60504 | 23mm | | 33,20 | | | 220 | |
| 60505 | 24mm | 51 | 34,20 | | | 230 | |
| 60506 | 25mm | | 36 | 36 | 16 | 260 | |
| 60507 | 26mm | | 37 | | | 265 | |
| 60508 | 27mm | 52 | 38 | | | 255 | |
| 60509 | 28mm | | 39 | | 22 | 265 | |
| 60510 | 29mm | | 40 | | | 275 | |
| 60511 | 30mm | 54 | 42 | | 38 | 290 | |
| 60512 | 32mm | | 44 | | | 320 | 10 1 |
| 60514 | 34mm | 56 | 47 | | 26 | 340 | |
| 60515 | 35mm | | 48 | | | 435 | |
| 60516 | 36mm | 58 | 50 | | 42 | 430 | |
| 60517 | 38mm | 60 | 52 | | 28 | 460 | |
| 60519 | 41mm | | 56 | | 45 | 575 | |
| 60520 | 42mm | 64 | 57 | | 30 | 560 | |
| 60521 | 46mm | 68 | 62 | | 47 | 750 | |
| 60522 | 50mm | 72 | 68 | | 36 | 835 | |
| 60523 | 55mm | 76 | 74 | | 48 | 1150 | |
| 60524 | 60mm | 78 | 80 | | 42 | 1180 | |

Cr-V DIN 3124

INCH.

| COD y | L | A | B | C | | | |
|-------|----------|----|-------|-------|----|----|-----|
| 60527 | 7/8" | | 50 | 32,20 | | 14 | 200 |
| 60528 | 15/16" | 51 | 34,20 | | 36 | 16 | 210 |
| 60529 | 1" | | 37 | | | | 250 |
| 60530 | 1.1/16" | | 38 | | | 22 | 255 |
| 60531 | 1.1/8" | 52 | 40 | | | 24 | 310 |
| 60532 | 1.1/4" | | 44 | | 38 | 26 | 325 |
| 60533 | 1.5/16" | 56 | 46 | | | 28 | 410 |
| 60534 | 1.3/8" | | 48 | | 42 | 30 | 420 |
| 60535 | 1.7/16" | 58 | 50 | | | 32 | 460 |
| 60536 | 1.1/2" | 60 | 52 | | 45 | 34 | 505 |
| 60537 | 1.5/8" | 64 | 56 | | | 36 | 570 |
| 60538 | 1.11/16" | 65 | 58 | | | 38 | 730 |
| 60539 | 1.13/16" | 68 | 62 | | 47 | 40 | 760 |
| 60540 | 1.7/8" | 70 | 64 | | 48 | 42 | 780 |
| 60541 | 2" | 72 | 68 | | | | |

Cr-V DIN 3124

LLAVE DE CARRACA REVERSIBLE / REVERSIBLE RATCHET HANDLE / CLE A CLIQUET / UMSCHALTKNARRE
CHIAVE A CRICCO REVERSIBILE / RATEL MET OMKEERMECHANISME / ROQUETE REVERSIVEL

| COD | | | | |
|-------|------|------|---|---|
| 61863 | 3/4" | 2260 | 6 | 1 |

DIN 3122



MANGO ARTICULADO / FLEXIBLE HANDLE / MANCHE ARTICULÉ / FLEXIBLE VERBINDUNG / IMPUGNATURA SNODABILE /
FLEXIBEL VERBINDING / CABO ARTICULADO

| COD | | | | |
|-------|------|------|------|---|
| 61473 | 3/4" | 1000 | 3,75 | 6 |
| 61456 | 3/4" | 485 | 1,9 | 6 |



MANGO CORREDIZO EN "T" / SLIDING "T" HANDLE / POIGNEE COULISSANTE / T-GLEITGRIFF / ASTA CON QUADRO SCORREVOLO
"T" WRINGSTAAF / CABO "T" CORREDIÇO

| COD | | | | |
|-------|------|------|---|---|
| 61864 | 3/4" | 1210 | 5 | 1 |

DIN 3122



ARTICULACION UNIVERSAL / UNIVERSAL JOINT / CARDAN UNIVERSEL / KARDANGELENK / SNODO CARDANICO DOP MET
CARDANGEWIRCH / CARDAN UNIVERSAL

| COD | | | | |
|-------|------|--|---|---|
| 61860 | 3/4" | | 6 | 1 |

DIN 3123



ALARGADERA / EXTENSION / RALLONGE / VERLÄNGERUNG / PROLUNGA / VERLENGSTUK / EXTENÇÃO

| COD | 3/4" | | | |
|-------|------|-----|---|---|
| 61865 | 4" | 410 | 5 | 1 |
| 61866 | 8" | 720 | | |

DIN 3123



- x 50% cromado aeroespacial / 50% aerospaceal chrome plating / 50% chromée aérospatiale
50% cromado pulido espejo / 50% mirror polished chrome plating / 50% polie chromée
- y 100% cromado pulido espejo / 100% mirror polished chrome plating / 100% polie chromée

1"

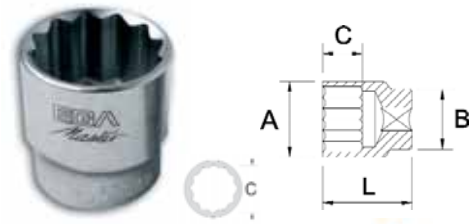
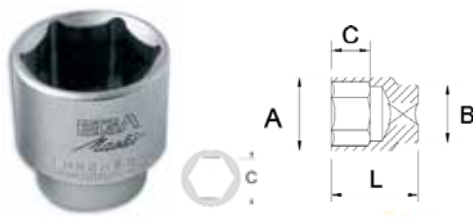

MM

| COD X | L | A | B | C | | | |
|-------|------|-----|-----|----|------|----|---|
| 65001 | 36mm | 65 | 51 | 28 | 530 | | |
| 65002 | 41mm | 70 | 57 | 32 | 630 | | |
| 65003 | 46mm | 75 | 65 | 34 | 750 | | |
| 65004 | 50mm | 70 | 55 | 34 | 885 | | |
| 65005 | 54mm | 74 | | | 1035 | | |
| 65006 | 55mm | 80 | 76 | 40 | 1180 | | |
| 65007 | 58mm | 79 | | 40 | 1280 | | |
| 65008 | 60mm | 84 | 82 | 42 | 1355 | | |
| 65009 | 63mm | 87 | 86 | 44 | 1600 | 10 | 1 |
| 65010 | 65mm | 88 | | 44 | 1600 | | |
| 65011 | 67mm | 90 | 90 | 46 | 1730 | | |
| 65012 | 70mm | 94 | | 48 | 1980 | | |
| 65013 | 71mm | 93 | 95 | 48 | 1980 | | |
| 65014 | 75mm | 97 | 100 | 52 | 2250 | | |
| 65015 | 77mm | 103 | 102 | 54 | 2400 | | |
| 65016 | 80mm | 105 | | 54 | 2500 | | |

Cr-V DIN 3124

INCH.

| COD X | L | A | B | C | | | |
|-------|----------|-----|-----|----|----|------|------|
| 65022 | 1.5/8" | 70 | 57 | 45 | 32 | 630 | |
| 65023 | 1.13/16" | 70 | 65 | 50 | 34 | 750 | |
| 65024 | 1.7/8" | 75 | 67 | | | 775 | |
| 65025 | 2" | 75 | 70 | | | 885 | |
| 65026 | 2.1/8" | | 74 | | | 1035 | |
| 65027 | 2.3/16" | 80 | 76 | 57 | 40 | 1180 | |
| 65028 | 2.1/4" | | 78 | | | 1290 | 10 1 |
| 65029 | 2.3/8" | 84 | 82 | | 42 | 1355 | |
| 65030 | 2.1/2" | 87 | 86 | | 44 | 1600 | |
| 65031 | 2.5/8" | 90 | 90 | | 44 | 1730 | |
| 65032 | 2.3/4" | 93 | 94 | | 48 | 1980 | |
| 65033 | 3" | 103 | 102 | 68 | 54 | 2470 | |
| 65034 | 3.1/8" | 105 | 105 | | 54 | 2500 | |

Cr-V DIN 3124

ADAPTADOR / ADAPTER / ADAPTEUR / VERBINDUNGSTEILE / ADATTATORE / ADAPTOR / REDUTOR

| COD | 1" | | | |
|-------|--------|-----|---|---|
| 65040 | 1-3/4" | 435 | 6 | 1 |



MANGO ARTICULADO / FLEXIBLE HANDLE / MANCHE ARTICULÉ / FLEXIBLE VERBINDUNG / IMPUGNATURA SNODABILE / FLEXIBEL VERBINDING / CABO ARTICULADO

| COD | 1" | L | Kg | |
|-------|----|------|-----|---|
| 61474 | 1" | 1000 | 4 | 6 |
| 61457 | 1" | 650 | 2,5 | 6 |



NEW
NEW

LLAVE DE CARRACA REVERSIBLE / REVERSIBLE RATCHET HANDLE / CLE A CLIQUET / UMSCHALTKNARRE
CHIAVE A CRICCO REVERSIBILE / RATEL MET OMKEERMECHANISME / ROQUETE REVERSIVEL

| COD | 1" | | | |
|-------|----|------|--|---|
| 65035 | 1" | 4410 | | 1 |



MANGO CORREDIZO EN "T" / SLIDING "T" HANDLE / POIGNEE COULISSANTE / T-GLEITGRIFF / ASTA CON QUADRO SCORREVOLO
"T" WRINGSTAAF / CABO "T" CORREDIÇO

| COD | 1" | | | |
|-------|----|------|---|---|
| 65036 | 1" | 3295 | 2 | 1 |



DIN 3122

ARTICULACION UNIVERSAL / UNIVERSAL JOINT / CARDAN UNIVERSEL / KARDANGELENK / SNODO CARDANICO
DOP MET CARDANGEWRIJCH / CARDAN UNIVERSAL

| COD | 1" | | | |
|-------|----|------|---|---|
| 65039 | 1" | 1215 | 6 | 1 |



DIN 3123

ALARGADERA / EXTENSION / RALLONGE / VERLÄNGERUNG / PROLUNGA / VERLENGSTUK / EXTENÇÃO

| COD | 1" | | | |
|-------|-----|------|---|---|
| 65037 | 8" | 1170 | 5 | 1 |
| 65038 | 16" | 2300 | | |



DIN 3123

x 50% cromado aeroespacial / 50% aerospaceal chrome plating / 50% chromée aérospatiale
50% cromado pulido espejo / 50% mirror polished chrome plating / 50% polie chromée





8









LLAVES DE VASO / SOCKET WRENCHES / DOUILLES / STECKSCHLÜSSEL BUSSOLE / DOPPEN / CHAVES DE CAIXA

KITS - SETS

1/4"



29 PCS.





| COD | |  |  |
|-------|--|---|--|
| 61958 | 4-5-6-7-8-9-10-11-12-13-14mm | | 0,85 |
| 61961 | 5/32"-3/16"-7/32"-1/4"-9/32" 5/16"-11/32"-3/8"-7/16"-1/2"-9/16" | | |

| | | |
|---|---|-----------------------|
| Carraca / Ratchet / Crécelle |  | ● |
| Alargadera / Extensión / Rallonge |  | 2"-6" |
| Mango en T / T Handle / T Poignee |  | ● |
| Articulación universal / Universal Joint Cardan Universel |  | ● |
| Punta hexagonal con vaso / Hex bit socket Embout hexagonal á douille |  | 3-4-5-6-8 |
| Punta plana con vaso / Flat bit socket Embout fente á douille |  | 4x0,6 - 5,5x1 - 7x1,2 |
| Punta Philips con vaso / Philips bit socket Embout Philips á douille |  | PH1-PH2-PH3-PH4 |
| Destornillador portavasos / Socket holder Tournevis porte douille |  | ● |



24 PCS.



| COD | |  |  |
|-------|---|---|--|
| 61791 | 4-5-6-7-8-9-10-11-12-13mm 3/16"-7/32"-1/4"-9/32"- 5/16"-11/32"-3/8"-7/16"-1/2" | | 0,8 |

| | | |
|--|---|----|
| Carraca / Ratchet / Crécelle |  | ● |
| Alargadera / Extensión / Rallonge |  | 2" |
| Articulación universal / Universal Joint Cardan Universel |  | ● |
| Mango articulado / Flexible handle Manche articulé |  | ● |
| Destornillador portavasos / Socket holder Tournevis porte douille |  | ● |



NEW

11 PCS.

| COD | |  |  |
|-------|--|---|--|
| 61323 | 4-5-6-7-8-9-10-11-12-13-14mm | | 0,4 |
| 61324 | 5/32"-3/16"-7/32"-1/4"-9/32" 5/16"-11/32"-3/8"-7/16"-1/2"-9/16" | | |

| | | |
|------------------------------|---|---|
| Carraca / Ratchet / Crécelle |  | ● |
|------------------------------|---|---|



8







LLAVES DE VASO / SOCKET WRENCHES / DOUILLES / STECKSCHLÜSSEL BUSSOLE / DOPPEN / CHAVES DE CAIXA



KITS - SETS







3/8"

16 PCS.

| COD | |  |  |
|--|---|---|---|
| 61959 | 8-10-11-12-13-14-15-17-19-21-22 mm | | 1,7 |
| 61962 | 5/16"-3/8"-7/16"-1/2"-9/16"-19/32" 5/8"-11/16"-3/4"-13/16"-7/8" | | |
| <hr/> | | | |
| Carraca / Ratchet / Crécelle |  | ● | |
| Alargadera / Extensión / Rallonge |  | | 5"-10" |
| Mango en T / T Handle / T Poignee |  | ● | |
| Articulación universal / Universal Joint Cardan Universel |  | ● | |





42 PCS.

| COD | |  | <ul style="list-style-type: none"> • Serie larga • Long serie • Serie Longue |  |
|--|---|---|---|---|
| 61792 | 9-10-11-12-13-14-15-16-17-18-19 mm | | 9-10-11-12-13-14-15-16-17-18-19 mm | 5 |
| | 3/8"-7/16"-1/2"-9/16"-5/8"-11/16"-3/4" | | 3/8"-7/16"-1/2"-9/16"-5/8"-11/16"-3/4" | |
| <hr/> | | | | |
| Carraca / Ratchet / Crécelle |  | ● | | |
| Alargadera / Extensión / Rallonge |  | | | 3"-6"-8" |
| Articulación universal / Universal Joint Cardan Universel |  | ● | | |
| Mango articulado / Flexible handle Manche articulé |  | ● | | |





NEW

16 PCS.

| COD | |  |  |
|------------------------------|---|---|---|
| 61341 | 8-9-10-11-12-13-14-15-16-17-18-19-20-21-22mm | | 1 |
| <hr/> | | | |
| Carraca / Ratchet / Crécelle |  | ● | |









13 PCS.

| COD | |  |  |
|------------------------------|---|---|---|
| 61342 | 5/16"-11/32"-3/8"-7/16"-1/2"-9/16"-19/32" 5/8"-11/16"-3/4"-13/16"-7/8" | | 0,9 |
| <hr/> | | | |
| Carraca / Ratchet / Crécelle |  | ● | |

KITS - SETS



1/2"

25 PCS.

| COD | |  |  |
|-------|--|---|--|
| 61960 | 10-11-12-13-14-15-16-17-18-19-20-21-22-23-24-26-27-28-30-32mm | | 4,25 |
| 61963 | 5/16"-3/8"-7/16"-1/2"-9/16"-19/32"-5/8"-21/32"-11/16"-3/4"-25/32"-13/16"-7/8"-15/16"-31/32"-1"-1.1/16"-1.1/8"-1.3/16"-1.1/4" | | |
| | Carraca / Ratchet / Crécelle |  | ● |
| | Alargadera / Extensión / Rallonge |  | 5"-10" |
| | Mango en T / T Handle / T Poignee |  | ● |
| | Articulación universal / Universal Joint Cardan Universel |  | ● |











17 PCS.

| COD | |  |  |
|-------|--|---|--|
| 61796 | 10-11-12-13-14-15-16-17-18-19-20-22-24-27-30-32mm | | 2,05 |
| 61798 | 5/16"-3/8"-7/16"-1/2"-9/16"-5/8"-11/16"-3/4"-13/16"-7/8"-15/16"-1"-1.1/16"-1.1/8"-1.3/16"-1.1/4" | | |
| 61797 | 10-11-12-13-14-15-16-17-18-19-20-22-24-27-30-32mm | | 2,05 |
| 61799 | 5/16"-3/8"-7/16"-1/2"-9/16"-5/8"-11/16"-3/4"-13/16"-7/8"-15/16"-1"-1.1/16"-1.1/8"-1.3/16"-1.1/4" | | |
| | Carraca / Ratchet / Crécelle |  | ● |









41 PCS.

| COD | |  |  |
|-------|---|---|--|
| 61793 | 10-11-12-13-14-15-16-17-18-19-20-21-22-23-24-27-30-32mm 3/8"-7/16"-1/2"-9/16"-5/8"-11/16"-3/4"-13/16"-7/8"-15/16"-1"-1.1/16"-1.1/8"-1.3/16"-1.1/4" | | 5,5 |
| | Carraca / Ratchet / Crécelle |  | ● |
| | Alargadera / Extensión / Rallonge |  | 6"-8" |
| | Mango en T / T Handle / T Poignee |  | ● |
| | Articulación universal / Universal Joint Cardan Universel |  | ● |
| | Mango articulado / Flexible handle Manche articulé |  | ● |
| | Vasos para bujías / Spark plug sockets Douille à bougie |  | 16-21mm |



NEW

33 PCS.

| COD | |  |  |
|-------|--|---|--|
| 65074 | 10-11-12-13-14-15-16-17-18-19-20-21-22-23-24mm | | 7 |
| 65075 | 3/8"-7/16"-1/2"-9/16"-5/8"-11/16"-3/4"-13/16"-7/8"-15/16"-1"-1.1/16"-1.1/8"-1.3/16"-1.1/4" | | |
| | Carraca / Ratchet / Crécelle |  | ● |
| | Alargadera / Extensión / Rallonge |  | 3"-5"-10" |
| | Mango articulado / Flexible handle Manche articulé |  | ● |
| | Articulación universal / Universal Joint Cardan Universel |  | ● |
| | Vasos para bujías / Spark plug sockets Douille à bougie |  | 16-21mm(65074) 5/8"-13/16"(65075) |



EXPOSITORES / DISPLAYS / PRESENTOIRS / STÄNDER / ESPOSITORE / DISPLAY STAND
1/2" 233 PCS. 1/2" 236 PCS.

| UN. | COD:65296 |
|-----|-----------|
| 12 | 8mm |
| 12 | 9mm |
| 12 | 10mm |
| 12 | 11mm |
| 12 | 12mm |
| 12 | 13mm |
| 12 | 14mm |
| 12 | 15mm |
| 11 | 16mm |
| 11 | 17mm |
| 10 | 18mm |
| 10 | 19mm |
| 9 | 20mm |
| 9 | 21mm |
| 8 | 22mm |
| 8 | 23mm |
| 8 | 24mm |
| 7 | 25mm |
| 7 | 26mm |
| 7 | 27mm |
| 7 | 28mm |
| 7 | 29mm |
| 6 | 30mm |
| 6 | 32mm |

| UN. | COD:65297 |
|-----|-----------|
| 12 | 8mm |
| 12 | 9mm |
| 12 | 10mm |
| 12 | 11mm |
| 12 | 12mm |
| 12 | 13mm |
| 12 | 14mm |
| 12 | 15mm |
| 11 | 16mm |
| 11 | 17mm |
| 10 | 18mm |
| 10 | 19mm |
| 9 | 20mm |
| 9 | 21mm |
| 8 | 22mm |
| 8 | 23mm |
| 8 | 24mm |
| 7 | 25mm |
| 7 | 26mm |
| 7 | 27mm |
| 7 | 28mm |
| 7 | 29mm |
| 6 | 30mm |
| 6 | 32mm |

| UN. | COD:65298 |
|-----|-----------|
| 24 | 5/16" |
| 24 | 3/8" |
| 12 | 7/16" |
| 12 | 1/22 |
| 24 | 9/16" |
| 22 | 5/8" |
| 20 | 11/16" |
| 19 | 3/4" |
| 9 | 13/16" |
| 16 | 7/8" |
| 8 | 15/16" |
| 14 | 1" |
| 7 | 1.1/16" |
| 7 | 1.1/8" |
| 6 | 1.3/16" |
| 6 | 1.1/4" |

| UN. | COD:65299 |
|-----|-----------|
| 24 | 5/16" |
| 24 | 3/8" |
| 12 | 7/16" |
| 12 | 1/22 |
| 12 | 9/16" |
| 12 | 19/32" |
| 11 | 5/8" |
| 11 | 21/32" |
| 20 | 11/16" |
| 10 | 3/4" |
| 9 | 25/32" |
| 9 | 13/16" |
| 16 | 7/8" |
| 8 | 15/16" |
| 7 | 31/32" |
| 7 | 1" |
| 7 | 1.1/16" |
| 7 | 1.1/8" |
| 6 | 1.3/16" |
| 6 | 1.1/4" |



3/4"

15 PCS.



| COD | | | | | |
|-------|--|----|--|--|------|
| 61861 | 22-24-27-30-32-36-38-41-46-50 | 4" | | | |
| 61862 | 7/8"-15/16"-1"-1.1/8"-1.1/4"-1.7/16"-1.1/2"-1.5/8"-1.13/16"-2" | 8" | | | 12,5 |



EXPOSITORES / DISPLAYS / PRESENTOIRS / STÄNDER / ESPOSITORE / DISPLAY STAND
86 PCS. 86 PCS.

| UN. | COD:65300 |
|-----|-----------|
| 7 | 19mm |
| 7 | 22mm |
| 7 | 24mm |
| 7 | 26mm |
| 7 | 27mm |
| 6 | 29mm |
| 6 | 30mm |
| 6 | 32mm |
| 5 | 34mm |
| 5 | 35mm |
| 5 | 36mm |
| 5 | 38mm |
| 5 | 41mm |
| 4 | 46mm |
| 4 | 50mm |

| UN. | COD:65301 |
|-----|-----------|
| 14 | 7/8" |
| 7 | 15/16" |
| 7 | 1" |
| 7 | 1.1/16" |
| 6 | 1.1/8" |
| 12 | 1.1/4" |
| 5 | 1.5/16" |
| 5 | 1.3/8" |
| 5 | 1.7/16" |
| 5 | 1.1/2" |
| 5 | 1.5/8" |
| 4 | 1.13/16" |
| 4 | 2" |



1"

15 PCS.



| COD | | | | | |
|-------|--|-----|--|--|----|
| 65041 | 36-41-46-50-55-60-65-70-75-80 | 8" | | | |
| 65042 | 1.13/16"-1.7/8"-2"-2.3/16"-2.1/4"-2.3/8"-2.1/2"-2.5/8"-2.3/4"-3.1/8" | 16" | | | 27 |



8

LLAVES DE VASO / SOCKET WRENCHES / DOUILLES / STECKSCHLÜSSEL BUSSOLE / DOPPEN / CHAVES DE CAIXA

LLAVES DE VASO DE IMPACTO / IMPACT SOCKET WRENCHES / DOUILLES A CHOC
KRAFTSCHRAUBEREINSATZ / BUSSOLA AD IMPULSI / SLAGDOPSLEUTELS
CHAVES DE CAIXA DE IMPACTO

3/8"

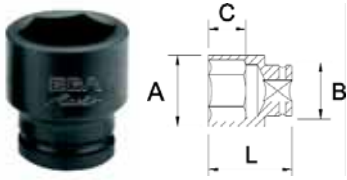

MM

| COD | Ø | L | A | B | C | Weight | Material |
|-------|------|----|----|----|----|--------|------------------|
| 60590 | 7mm | 12 | | | | 41 | Cr-V DIN 3129 |
| 60591 | 8mm | 13 | | | | | |
| 60592 | 9mm | 14 | | | | 43 | |
| 60593 | 10mm | 16 | | 19 | 14 | | |
| 60594 | 11mm | 17 | | | | 44 | |
| 60595 | 12mm | 18 | | | | | |
| 60596 | 13mm | 20 | 20 | 15 | | 60 | |
| 60597 | 14mm | 21 | 21 | | | | |
| 60598 | 15mm | 22 | 22 | | | 62 | |
| 60599 | 16mm | 23 | 23 | 16 | | | |
| 60600 | 17mm | 24 | 24 | | | 72 | |
| 60601 | 18mm | 26 | 26 | | | | |
| 60602 | 19mm | 27 | 27 | | | | |

Cr-V DIN 3129

INCH.

| COD | Ø | L | A | B | C | Weight | Material |
|-------|--------|----|----|----|----|--------|------------------|
| 65205 | 5/16" | 13 | | | | 43 | Cr-V DIN 3129 |
| 65206 | 3/8" | 15 | | | | 44 | |
| 65207 | 7/16" | 17 | | 19 | 14 | 60 | |
| 65208 | 1/2" | 19 | | | 15 | | |
| 65209 | 9/16" | 21 | 21 | | | 62 | |
| 65210 | 5/8" | 23 | 23 | 16 | | | |
| 65211 | 11/16" | 25 | 25 | | | 72 | |
| 65212 | 3/4" | 27 | 27 | | | | |

Cr-V DIN 3129

1/2"

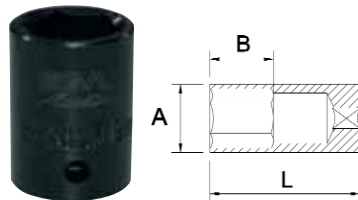

MM

| COD | Ø | L | A | B | C | Weight | Material |
|-------|------|----|---|----|---|--------|------------------|
| 60603 | 10mm | 17 | | | | | Cr-V DIN 3129 |
| 60604 | 11mm | 18 | | | | | |
| 60605 | 12mm | 19 | | | | 86 | |
| 60606 | 13mm | 20 | | 14 | | | |
| 60607 | 14mm | 22 | | | | 106 | |
| 60608 | 15mm | 23 | | | | | |
| 60609 | 16mm | 24 | | | | | |
| 60610 | 17mm | 26 | | | | | |
| 60611 | 18mm | 27 | | 15 | | 127 | |
| 60612 | 19mm | 28 | | | | | |
| 60613 | 20mm | 29 | | 19 | | | |
| 60614 | 21mm | 31 | | | | | |
| 60615 | 22mm | 32 | | 20 | | 132 | |
| 60616 | 24mm | 34 | | | | 137 | |
| 60617 | 27mm | 38 | | | | 171 | |
| 60618 | 29mm | 40 | | | | 190 | |
| 60619 | 30mm | 42 | | 21 | | 196 | |
| 60619 | 32mm | 44 | | | | 205 | |

Cr-V DIN 3129

INCH.

| COD | Ø | L | A | B | C | Weight | Material |
|-------|---------|----|----|----|----|--------|------------------|
| 65213 | 3/8" | 16 | | | | 86 | Cr-V DIN 3129 |
| 65214 | 7/16" | 18 | | | | | |
| 65215 | 1/2" | 20 | | 23 | 14 | 127 | |
| 65216 | 9/16" | 22 | | | | | |
| 65217 | 5/8" | 24 | 24 | 15 | | 132 | |
| 65218 | 11/16" | 26 | 26 | 16 | | 137 | |
| 65219 | 3/4" | 28 | 28 | | | 145 | |
| 65220 | 13/16" | 30 | 30 | 19 | | 171 | |
| 65221 | 7/8" | 32 | 32 | 20 | | 190 | |
| 65222 | 15/16" | 34 | 34 | | | 205 | |
| 65223 | 1" | 36 | | | | | |
| 65224 | 1.1/16" | 38 | | | | | |
| 65225 | 1.1/8" | 40 | | 35 | 21 | | |
| 65226 | 1.1/4" | 44 | | | | | |

Cr-V DIN 3129

LLAVES DE VASO DE IMPACTO / IMPACT SOCKET WRENCHES / DOUILLES A CHOC
 KRAFTSCHRAUBEREINSATZ / BUSSOLA AD IMPULSI / SLAGDOPSLEUTELS
 CHAVES DE CAIXA DE IMPACTO

SERIE LARGA / LONG SERIE / SERIE LONGUE / LANGE SERIE / SERIE LUNGA / LANGE SERIE /
 SERIE LONGA

1/2"

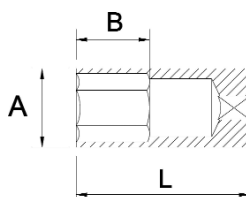

MM

| COD | Ø | L | A | B | IF | 6 | 1 | |
|-------|------|----|-----|----|-----|---|---|-----|
| 60660 | 10mm | 78 | 17 | 27 | 190 | 6 | 1 | |
| 60661 | 11mm | | 18 | | | | | |
| 60662 | 12mm | | 19 | | | | | |
| 60663 | 13mm | | 20 | | | | | |
| 60664 | 14mm | | 22 | | | | | |
| 60665 | 16mm | | 24 | | | | | |
| 60666 | 17mm | | 26 | | | | | |
| 60667 | 18mm | | 27 | | | | | |
| 60668 | 19mm | | 28 | 37 | | | | 263 |
| 60669 | 21mm | | 31 | | | | | 310 |
| 60670 | 22mm | | 32 | | | | | 320 |
| 60671 | 23mm | | 33 | | | | | 340 |
| 60672 | 24mm | | 34 | | | | | 405 |
| 60673 | 27mm | | 38 | | | | | 425 |
| 60674 | 29mm | | 40 | | | | | 435 |
| 60675 | 30mm | | 42 | | | | | 450 |
| 60676 | 32mm | 44 | 450 | | | | | |

Cr-Mo DIN 3129

3/4"

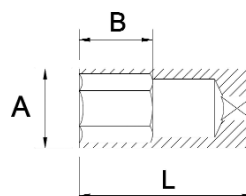

MM

| COD | Ø | L | A | B | IF | 6 | 1 | |
|-------|------|----|------|-----|-----|---|---|-----|
| 60679 | 19mm | 90 | 33 | 28 | 630 | 1 | 1 | |
| 60680 | 21mm | | 35 | | | | | |
| 60681 | 22mm | | 37 | | | | | |
| 60682 | 24mm | | 39 | | | | | |
| 60683 | 26mm | | 41,5 | 36 | | | | |
| 60684 | 27mm | | 42,5 | 53 | | | | |
| 60685 | 30mm | | 46,5 | 54 | | | | 655 |
| 60686 | 32mm | | 49 | 56 | | | | 835 |
| 60687 | 33mm | | 50,5 | 58 | | | | 885 |
| 60688 | 34mm | | 51,5 | | | | | 915 |
| 60689 | 36mm | | 54 | | | | | 935 |
| 60690 | 38mm | | 56,5 | | | | | 940 |
| 60691 | 41mm | | 60 | 950 | | | | |

Cr-Mo DIN 3129

LLAVES DE VASO DE IMPACTO / IMPACT SOCKET WRENCHES / DOUILLES A CHOC
KRAFTSCHRAUBEREINSATZ / BUSSOLA AD IMPULSI / SLAGDOPSLEUTELS
CHAVES DE CAIXA DE IMPACTO

3/4"

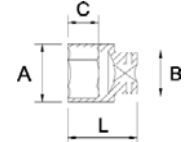
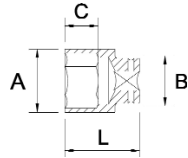

MM

| COD | Ø | L | A | B | C | Weight | Material | Standard |
|-------|------|----|----|----|----|--------|----------|----------|
| 60620 | 19mm | | 33 | | | | | |
| 60621 | 21mm | | 35 | | | | | |
| 60622 | 22mm | 50 | 37 | | | | | |
| 60623 | 23mm | | 38 | | | 18 | | |
| 60624 | 24mm | | 39 | | 22 | 235 | | |
| 60625 | 26mm | | 41 | | 24 | | | |
| 60626 | 27mm | | 43 | | 26 | | | |
| 60627 | 28mm | 53 | 44 | | | | | |
| 60628 | 29mm | | 45 | | | 310 | | |
| 60629 | 30mm | | 46 | | | 422 | 1 | 1 |
| 60630 | 32mm | | 49 | | | 436 | | |
| 60631 | 33mm | 56 | 51 | | | 462 | | |
| 60632 | 34mm | | 51 | | 27 | 485 | | |
| 60633 | 36mm | | 54 | | | 502 | | |
| 60634 | 38mm | | 56 | | | 565 | | |
| 60635 | 41mm | 57 | 60 | | | 600 | | |
| 60636 | 42mm | | 61 | | | 690 | | |
| 60637 | 46mm | 62 | 66 | | 28 | 700 | | |
| 60638 | 50mm | 72 | 71 | 54 | | 1085 | | |

Cr-Mo DIN 3129

INCH.

| COD | Ø | L | A | B | C | Weight | Material | Standard |
|-------|----------|----|----|----|----|--------|----------|----------|
| 65227 | 3/4" | | 33 | | | | | |
| 65228 | 13/16" | | 35 | | | | | |
| 65229 | 7/8" | 50 | 37 | | | 18 | | |
| 65230 | 15/16" | | 39 | | | 235 | | |
| 65231 | 1" | | 41 | | 22 | | | |
| 65232 | 1.1/16" | | 43 | | 26 | | | |
| 65233 | 1.1/8" | 53 | 45 | | | 310 | | |
| 65234 | 1.3/16" | | 46 | | | 422 | | |
| 65235 | 1.1/4" | | 49 | | 44 | 436 | | |
| 65236 | 1.5/16" | 56 | 51 | | | 462 | 1 | 1 |
| 65237 | 1.3/8" | | 53 | | 27 | 485 | | |
| 65238 | 1.7/16" | | 55 | | | 502 | | |
| 65239 | 1.1/2" | 57 | 56 | | | 565 | | |
| 65240 | 1.5/8" | | 60 | | | 600 | | |
| 65241 | 1.11/16" | 62 | 63 | | | 690 | | |
| 65242 | 1.3/4" | | 65 | | | 700 | | |
| 65243 | 1.7/8" | 67 | 69 | | 28 | 750 | | |
| 65244 | 2" | 72 | 73 | 54 | | 1085 | | |

Cr-Mo DIN 3129

1"

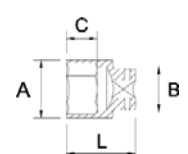
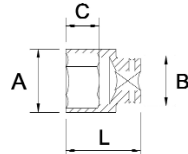

MM

| COD | Ø | L | A | B | C | Weight | Material | Standard |
|-------|------|-----|-----|-----|----|--------|----------|----------|
| 60640 | 38mm | 65 | 59 | | | 805 | | |
| 60641 | 41mm | 65 | 63 | | | 840 | | |
| 60642 | 42mm | 68 | 64 | 54 | | 860 | | |
| 60643 | 46mm | 74 | 69 | | | 1000 | | |
| 60644 | 50mm | | 74 | | 32 | 1050 | | |
| 60645 | 52mm | 80 | 77 | 80 | | 1090 | | |
| 60646 | 54mm | | 79 | | | 1125 | | |
| 60647 | 55mm | | 81 | | 45 | 1220 | | |
| 60648 | 56mm | 85 | 82 | 85 | | 1270 | 1 | 1 |
| 60649 | 57mm | | 83 | | | 1300 | | |
| 60650 | 58mm | | 85 | | | 1350 | | |
| 60651 | 60mm | | 87 | | 47 | 1440 | | |
| 60652 | 62mm | 89 | 89 | 89 | | 1450 | | |
| 60653 | 63mm | | 91 | | | 1540 | | |
| 60654 | 65mm | 93 | 93 | 93 | | 1550 | | |
| 60655 | 70mm | 98 | 99 | 98 | 50 | 1710 | | |
| 60656 | 75mm | 100 | 106 | 100 | 53 | 3600 | | |

Cr-Mo DIN 3129

INCH.

| COD | Ø | L | A | B | C | Weight | Material | Standard |
|-------|----------|----|----|----|----|--------|----------|----------|
| 65253 | 1" | | 44 | | | 26 | 550 | |
| 65254 | 1.1/16" | 58 | 46 | | | 560 | | |
| 65255 | 1.1/8" | | 48 | | | 600 | | |
| 65256 | 1.3/16" | 60 | 49 | | | 670 | | |
| 65257 | 1.1/4" | | 52 | | 27 | 710 | | |
| 65258 | 1.5/16" | 61 | 54 | | | 750 | | |
| 65259 | 1.3/8" | | 56 | | | 770 | | |
| 65260 | 1.7/16" | | 58 | | | 800 | | |
| 65261 | 1.1/2" | 65 | 59 | | | 805 | | |
| 65262 | 1.9/16" | | 62 | | | 830 | | |
| 65263 | 1.5/8" | | 63 | 54 | 28 | 840 | 1 | 1 |
| 65264 | 1.11/16" | 68 | 66 | | | 870 | | |
| 65265 | 1.3/4" | | 68 | | | 900 | | |
| 65266 | 1.13/16" | | 69 | | | 950 | | |
| 65267 | 1.7/8" | 74 | 72 | | 32 | 1000 | | |
| 65268 | 2" | | 76 | | | 1050 | | |
| 65269 | 2.1/8" | 80 | 79 | | | 1150 | | |
| 65270 | 2.1/4" | 85 | 83 | | | 1300 | | |
| 65271 | 2.3/8" | 89 | 87 | | 47 | 1450 | | |
| 65272 | 2.1/2" | | 91 | | | 1500 | | |
| 65273 | 2.5/8" | 93 | 96 | | | 1600 | | |

Cr-Mo DIN 3129

LLAVES DE VASO DE IMPACTO / IMPACT SOCKET WRENCHES / DOUILLES A CHOC
KRAFTSCHRAUBEREINSATZ / BUSSOLA AD IMPULSI / SLAGDOPSLEUTELS
CHAVES DE CAIXA DE IMPACTO

1.1/2"

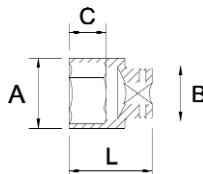

MM

| COD | Socket Size | L | A | B | C | Weight | Material | Notes |
|-------|-------------|-----|-----|----|------|--------|----------|-------|
| 65426 | 46mm | 84 | 74 | 86 | 31 | 2,3 | 1 | - |
| 65427 | 50mm | | 79 | | 31 | 2,5 | | |
| 65428 | 55mm | 90 | 86 | | 32 | 2,9 | | |
| 65429 | 60mm | | 92 | | 35 | 3,2 | | |
| 65430 | 65mm | 95 | 97 | | 36 | 3,7 | | |
| 65431 | 70mm | 100 | 103 | | 40 | 4 | | |
| 65432 | 75mm | 105 | 108 | | | 4,5 | | |
| 65433 | 80mm | 110 | 115 | | 41 | 5,5 | | |
| 65434 | 85mm | | 122 | | 42 | 5,7 | | |
| 65435 | 90mm | 112 | 128 | | 44 | 6,5 | | |
| 65436 | 95mm | 115 | 135 | | 45 | 7,5 | | |
| 65437 | 100mm | | 140 | | 44 | 7,8 | | |
| 65438 | 105mm | 120 | 146 | | 45 | 8,6 | | |
| 65439 | 110mm | 124 | 153 | | 46 | 9,8 | | |
| 65440 | 115mm | 128 | 160 | | 48 | 10 | | |
| 65441 | 120mm | 132 | 166 | | 49 | 10,4 | | |
| 65442 | 125mm | 136 | 173 | 51 | 11 | | | |
| 65443 | 130mm | 140 | 180 | 53 | 11,3 | | | |
| 65444 | 135mm | 145 | 186 | 55 | 11,8 | | | |
| 65445 | 140mm | 150 | 190 | 56 | 12,5 | | | |
| 65446 | 145mm | | 196 | 56 | 14 | | | |
| 65447 | 150mm | 155 | 200 | | | | | |

Cr-Mo DIN 3129

2.1/2"

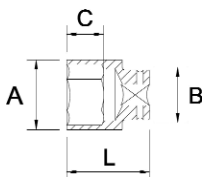



MM

| COD | Socket Size | L | A | B | C | Weight | Material | Notes |
|-------|-------------|-----|-----|-----|------|--------|----------|-------|
| 65452 | 70mm | 125 | 110 | 128 | 36 | 7,6 | 1 | - |
| 65453 | 75mm | | 118 | | 40 | | | |
| 65454 | 80mm | 132 | 124 | | 41 | 8 | | |
| 65455 | 85mm | | 128 | | 42 | 9 | | |
| 65456 | 90mm | 135 | 44 | | 10 | | | |
| 65457 | 95mm | 140 | 138 | | 45 | 11 | | |
| 65458 | 100mm | 146 | 146 | | 46 | 11,5 | | |
| 65459 | 105mm | 146 | 155 | | 48 | 12 | | |
| 65460 | 110mm | 155 | 158 | | 49 | 12,4 | | |
| 65461 | 115mm | 158 | 167 | | 51 | 12,9 | | |
| 65462 | 120mm | 160 | 175 | | 53 | 13,5 | | |
| 65463 | 125mm | 165 | 180 | | 55 | 13,8 | | |
| 65464 | 130mm | 169 | 185 | | 56 | 14,5 | | |
| 65465 | 135mm | 175 | 188 | | 58 | 16 | | |
| 65466 | 140mm | 180 | 200 | | 59 | 16,3 | | |
| 65467 | 145mm | 183 | 205 | | 59 | 16,8 | | |
| 65468 | 150mm | 192 | 208 | 62 | 17,1 | | | |
| 65469 | 155mm | 195 | 215 | 63 | 18,1 | | | |
| 65470 | 160mm | 200 | 225 | 64 | 18,3 | | | |
| 65471 | 165mm | 204 | 228 | 65 | 18,6 | | | |
| 65472 | 170mm | 207 | 235 | 66 | 19,1 | | | |
| 65473 | 175mm | 211 | 240 | 67 | 19,4 | | | |
| 65474 | 180mm | 217 | 248 | 68 | 20 | | | |
| 65475 | 185mm | 218 | 255 | | | | | |
| 65476 | 190mm | 220 | 265 | | | | | |
| 65477 | 200mm | 225 | 275 | | | | | |

Cr-Mo DIN 3129





ADAPTADOR / ADAPTER / ADAPTATEUR / VERBINDUNGSTEIL / ADATTATORE / ADAPTOR / REDUTOR

| COD | 3/8" | 1/2" | 3/4" | 1" | 1.1/2" | 2.1/2" |  |  |  |
|-------|----------|----------|----------|--------|--------------|---------------|--|---|---|
| 60696 | 3/8-1/2" | - | - | - | - | - | 50 | | |
| 60698 | - | 1/2-3/8" | - | - | - | - | 110 | | |
| 60699 | - | 1/2-3/4" | - | - | - | - | 130 | | |
| 60700 | - | - | 3/4-1/2" | - | - | - | 370 | | |
| 60701 | - | - | 3/4-1" | - | - | - | 410 | 6 | 1 |
| 60702 | - | - | - | 1-3/4" | - | - | 600 | | |
| 65448 | - | - | - | - | 1.1/2"-1" | - | 2100 | | |
| 65449 | - | - | - | - | 1.1/2"2.1/2" | - | 4000 | | |
| 65478 | - | - | - | - | - | 2.1/2"-1.1/2" | 4500 | | |

DIN 3121





ARTICULACION UNIVERSAL / UNIVERSAL JOINT / CARDAN UNIVERSEL / KARDANGELENK / SNODO CARDANICO
DOP MET CARDANGEWIRCH / CARDAN UNIVERSAL

| COD |  |  |  |  |
|-------|---|---|---|---|
| 60704 | 3/8" | 80 | | |
| 60705 | 1/2" | 180 | 6 | 1 |
| 60706 | 3/4" | 600 | | |
| 60707 | 1" | 1245 | | |

DIN 3121





ALARGADERA / EXTENSION / RALLONGE / VERLÄNGERUNG / PROLUNGA / VERLENGSTUK / EXTENÇÃO

| COD | 3/8" | 1/2" | 3/4" | 1" | 1.1/2" |  |  |  |
|-------|------|------|------|-----|--------|---|--|---|
| 60710 | 75 | - | - | - | - | 80 | | |
| 60711 | - | 125 | - | - | - | 220 | | |
| 60714 | - | - | 175 | - | - | 850 | | |
| 60716 | - | - | - | 175 | - | 1510 | 6 | 1 |
| 60717 | - | - | - | 330 | - | 2575 | | |
| 65450 | - | - | - | - | 250 | 5500 | | |
| 65451 | - | - | - | - | 300 | 6500 | | |

DIN 3121





ANILLA DE SEGURIDAD / SECURITY O-RING / BAGUES DE SECURITE / SICHERUNGSRING / ANELLO SPACCATO
VEILIGHEIDSDICHTING / ANEL DE SEGURANÇA

| COD | 3/4" | 1" |  |  |  |
|-------|-------|-------|---|---|---|
| 60724 | 19-46 | - | 5 | | |
| 60725 | 50 | - | | 6 | 1 |
| 60726 | - | 38-70 | 10 | | |
| 60727 | - | 75 | | | |



PASADOR DE SEGURIDAD / SECURITY PIN / GOUPILLE DE SECURITE / SICHERUNGSSTIFT / COPPIGLIA / VEILIGHEIDSPIN
PINO DE SEGURANÇA

| COD | 3/4" | 1" |  |  |  |
|-------|-------|-------|---|---|---|
| 60732 | 19-46 | - | 10 | | |
| 60733 | 50 | - | | 6 | 1 |
| 60734 | - | 38-70 | 15 | | |
| 60735 | - | 75 | | | |



JUEGOS / SETS / COFRETS / SÄTZE / ASSORTIMENTI / JOGOS

1/2" mm

| COD | pcs. |  | Kg. |
|-------|------|---|-----|
| 60693 | 10 | 13-14-16-17-19-21-22-24-27-30 | 3,5 |
| 61265 | | 10-11-12-13-14-17-19-21-22-24 | 3 |

 SERIE LARGA / LONG SERIE / SERIE LONGUE / LANGE SERIE / SERIE LUNGA
 LANGE SERIE / SERIE LONGA

| COD | pcs. |  | Kg. |
|-------|------|---|-----|
| 61266 | 10 | 10-11-12-13-14-17-19-21-22-24 | 4 |

3/4" mm

| COD | pcs. |  | Kg. |
|-------|------|--|-----|
| 60694 | 8 | 26-27-29-30-32-34-36-38 | 5,1 |
| 61269 | | 21-22-24-27-30-32-36-41 | 4,8 |

 SERIE LARGA / LONG SERIE / SERIE LONGUE / LANGE SERIE / SERIE LUNGA
 LANGE SERIE / SERIE LONGA

| COD | pcs. |  | Kg. |
|-------|------|---|-----|
| 61270 | 8 | 21-22-24-27-30-32-36-41 | 5,8 |

1" mm

| COD | pcs. |  | Kg. |
|-------|------|---|-----|
| 61273 | 9 | 24-27-30-32-36-38-41-46-50 | 7,5 |

 SERIE LARGA / LONG SERIE / SERIE LONGUE / LANGE SERIE / SERIE LUNGA
 LANGE SERIE / SERIE LONGA

| COD | pcs. |  | Kg. |
|-------|------|---|-----|
| 61274 | 9 | 24-27-30-32-36-38-41-46-50 | 7,5 |



8

LLAVES DE VASO / SOCKET WRENCHES / DOUILLES / STECKSCHLÜSSEL BUSSOLE / DOPPEN / CHAVES DE CAIXA

JUEGOS / SETS / COFRETS / SÄTZE / ASSORTIMENTI / JOGOS

1/2" inch

| COD | pcs. | | Kg. |
|-------|------|--|-----|
| 61267 | 11 | 3/8"-7/16"-1/2"-9/16"-5/8"-11/16"-3/4"-13/16"-7/8"-15/16"-1" | 3,2 |



SERIE LARGA / LONG SERIE / SERIE LONGUE / LANGE SERIE / SERIE LUNGA
LANGE SERIE / SERIE LONGA

| COD | pcs. | | Kg. |
|-------|------|--|-----|
| 61268 | 11 | 3/8"-7/16"-1/2"-9/16"-5/8"-11/16"-3/4"-13/16"-7/8"-15/16"-1" | 4,2 |



3/4" inch

| COD | pcs. | | Kg. |
|-------|------|--|-----|
| 61271 | 8 | 1"-1.1/16"-1.1/8"-1.1/4"-1.5/16"-1.3/8"-1.7/16"-1.1/2" | 5 |



SERIE LARGA / LONG SERIE / SERIE LONGUE / LANGE SERIE / SERIE LUNGA
LANGE SERIE / SERIE LONGA

| COD | pcs. | | Kg. |
|-------|------|--|-----|
| 61272 | 8 | 1"-1.1/16"-1.1/8"-1.1/4"-1.5/16"-1.3/8"-1.7/16"-1.1/2" | 6 |



1" inch

| COD | pcs. | | Kg. |
|-------|------|---|-----|
| 61275 | 9 | 1"-1.1/8"-1.1/4"-1.5/16"-1.1/2"-1.5/8"-1.3/4"-1.7/8"-2" | 7,6 |



SERIE LARGA / LONG SERIE / SERIE LONGUE / LANGE SERIE / SERIE LUNGA
LANGE SERIE / SERIE LONGA

| COD | pcs. | | Kg. |
|-------|------|---|-----|
| 61276 | 9 | 1"-1.1/8"-1.1/4"-1.5/16"-1.1/2"-1.5/8"-1.3/4"-1.7/8"-2" | 7,6 |



NEW



**DESTORNILLADORES / SCREWDRIVERS / TOURNEVIS / SCHRAUBENDREHER-
CACCIAVITI / SCHROEVENDRAAIER / CHAVES DE FENDA**

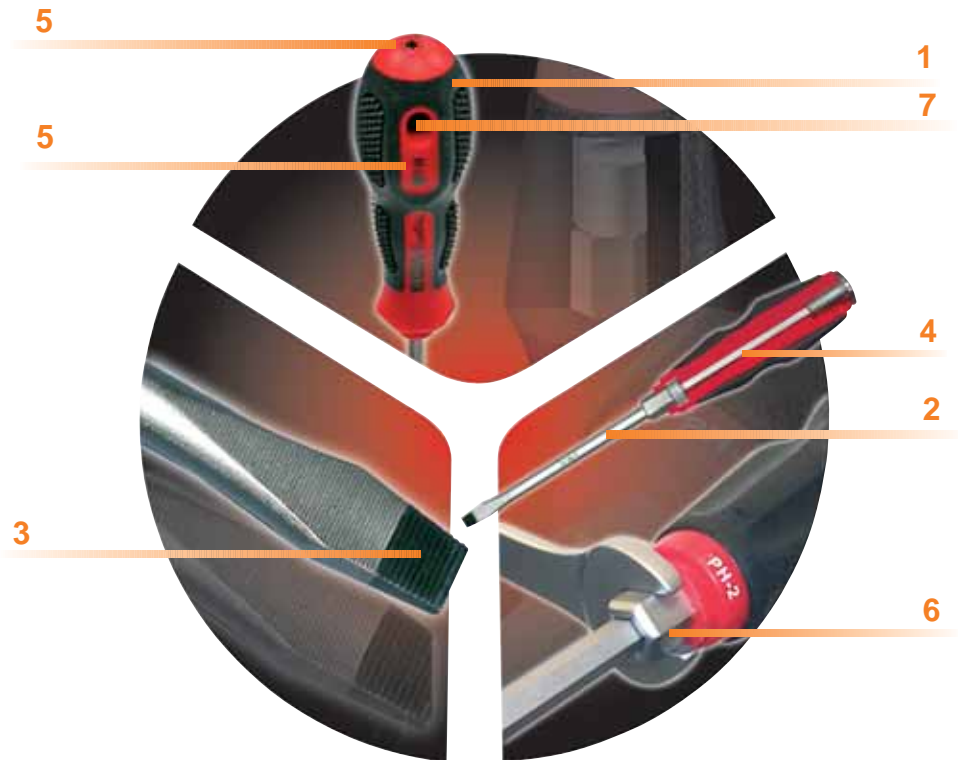

1 Equipados con mangos ergonómicos y antideslizantes más amplios, ofrecen un agarre superior evitando deslizamientos.

Oversized ergonomic & anti-slippery handles offer optimal grip for avoiding slippage.

Pourvus de manches ergonomiques et anti-dérapants plus volumineux.

3 Su innovador sistema de punta antideslizante y magnética facilita el posicionamiento y evita deslizamientos imprevistos.

The innovative "non-slip" anti-slippery and magnetic tip system allow an easier and safer positioning of the screwdriver, avoiding undesired slides.

Son système innovateur de tête anti-dérapante et magnétique, facilite le positionnement et fait éviter les dérapages.

5 El marcaje doble vertical y frontal de tipo y tamaño facilita la identificación rápida del destornillador que necesitamos emplear.

Type and size double marking of easy and efficient identification of the screwdriver to be used.

Le double marquage de type et de dimension facilite l'identification de l'outil recherché.

7 El agujero del mango permite apalancar.

Go-through hole in the handle enables tommy bar using.

Le trou sur le manche permet de serrer à l'aide d'une barre.

2 Su varilla exclusiva de aleación cromo-molibdeno-vanadio permite aprietes un 30% superiores a los destornilladores estándar.

Its exclusive chrome-molybdenum-vanadium alloy enables 30% higher tightening than traditional screwdrivers.

Sa lame "exclusivité" en alliage chrome molybdène vanadium, permet un serrage supérieur de 30% par rapport aux modèles standards.

4 Varilla pasante para el modelo Masterpunch, permite el golpeo en su parte superior.

Go-through bar enables hammering on the Masterpunch screwdriver's upper side.

Tige traversante pour le modèle Masterpunch, qui permet de frapper sur la partie supérieure.



6 Modelos equipados con varilla hexagonal para aprietes con llaves.

Hexagonal bar screwdrivers available for strong tightening with wrenches.

Modèles pourvus de lames hexagonales pour le serrage avec une clé.

8 Patentado.

Patented.

Breveté.

9 DESTORNILLADORES / SCREWDRIVERS / TOURNEVIS / SCHRAUBENDREHER CACCIAVITI / SCHROEVENDRAAIER / CHAVES DE FENDA



MASTERTORK



- SISTEMA DE PUNTA ANTIDESLIZANTE **NON-SLIP** Y MAGNETICA
- **NON-SLIP** ANTISLIPPERY MAGNETIC TIP
- **NON-SLIP** POINTE BRUNIE ANTIDÉRAPANTE ET MAGNETIQUE
- **NON-SLIP** ANTI-RUTSCH-SPITZE

- PUNTA ANTISCIVOLO **NON-SLIP**
- **NON-SLIP** ANTI SLIP TIP
- SISTEMA DE PUNTA ANTIDESLIZANTE DE CHAVE **NON-SLIP**

MECANICO / SLOTTED / MECANICIEN / FÜR SCHLITZSCHRAUBEN / PER MECCANICI / SCHROEVENDAAIER VOOR SLEUFSCHROEVEN / MECÁNICO

| COD | | | | | | | | | | |
|-------|-----|-----|-----|-----|----|---|---|-----|-----|-----|
| 66400 | 3 | 80 | 0,5 | 83 | 16 | 1 | | | | |
| 66401 | 4 | 100 | 0,8 | | | | | | | |
| 66402 | 5,5 | 125 | 1 | 105 | 8 | | 1 | | | |
| 66403 | | | | | | | | 6,5 | 1,2 | 115 |
| 66404 | 8 | 150 | 1,6 | 128 | 6 | | | 1 | | |
| 66405 | 10 | 200 | 2 | | | | | | | |
| 66406 | 12 | 250 | 2,5 | 128 | 6 | | | | 1 | |
| 66407 | 14 | | 2,5 | | | | | | | |
| 66408 | 4 | 100 | 0,8 | 83 | 16 | | | | | 1 |
| 66409 | 5,5 | 125 | 1 | 105 | 8 | | | | | |
| 66410 | 6,5 | 150 | 1,2 | 115 | 6 | | | | | |
| 66411 | 8 | 200 | 1,6 | 128 | 11 | | | | | |
| 66412 | 10 | 250 | 2 | 10 | 16 | 1 | | | | |
| 66413 | 12 | | 2,5 | | | | | | | |
| 66414 | 14 | 2,5 | 10 | 16 | | | | | | |



| COD | | | | | | | |
|-------|-----|-----|-----|-----|----|----|----|
| 66413 | 4 | 100 | 0,8 | 83 | 4 | - | 16 |
| 66414 | 5,5 | 125 | 1 | 105 | 6 | - | 8 |
| 66415 | 6,5 | 150 | 1,2 | 115 | 8 | 11 | 6 |
| 66416 | 8 | 200 | 1,6 | 128 | 10 | 16 | 6 |
| 66417 | 10 | 250 | 2 | 128 | 10 | 16 | 6 |
| 66418 | 12 | 250 | 2,5 | 128 | 10 | 16 | 6 |
| 66419 | 14 | 250 | 2,5 | 128 | 10 | 16 | 6 |



ELECTRICISTA / ELECTRICIAN / ELECTRICIEN / ELEKTRIK / SCHROEVENDRAAIER VOOR SLEUFSCHROEVEN MODEL ELECTRICIEN / PER ELETTRICISTI / ELETRECISTA

| COD | | | | | | | | | | |
|-------|-----|-----|-----|-----|----|---|-----|---|-----|---|
| 66421 | 3 | 60 | 0,5 | 83 | 16 | 1 | | | | |
| 66422 | | 100 | | | | | | | | |
| 66423 | 4 | 125 | 0,8 | 105 | 8 | | 1 | | | |
| 66424 | | 150 | | | | | | | | |
| 66425 | 5,5 | 175 | 1 | 115 | 6 | | | 1 | | |
| 66426 | | | | | | | | | 200 | |
| 66427 | 8 | 175 | 1,2 | 128 | 6 | | | | 1 | |
| 66428 | 2,5 | 75 | 0,4 | 83 | 16 | | | | | 1 |
| 66429 | | | | | | | | | | |
| 66430 | 3 | 100 | 0,5 | 105 | 8 | | | | | |
| 66431 | 4 | 125 | 0,8 | | | | | | | |
| 66432 | 5,5 | 150 | 1 | 115 | 6 | 1 | | | | |
| 66433 | | | | | | | 6,5 | | | |
| 66434 | 8 | 175 | 1,6 | 128 | 6 | | 1 | | | |
| 66435 | 10 | 200 | 1,6 | 128 | 6 | | | | | |



| COD | | | | | | | | | |
|-------|-----|-----|-----|-----|----|---|-----|---|-----|
| 66428 | 2,5 | 75 | 0,4 | 83 | 16 | 1 | | | |
| 66429 | | | | | | | 100 | | |
| 66430 | 3 | 100 | 0,5 | 105 | 8 | | 1 | | |
| 66431 | 4 | 125 | 0,8 | | | | | | |
| 66432 | 5,5 | 150 | 1 | 115 | 6 | | | 1 | |
| 66433 | | | | | | | | | 6,5 |
| 66434 | 8 | 175 | 1,6 | 128 | 6 | | | | 1 |
| 66435 | 10 | 200 | 1,6 | 128 | 6 | | | | |



PHILIPS

| COD | | | | | | |
|-------|------|----|-----|-----|----|---|
| 66438 | PH-0 | 3 | 60 | 83 | 16 | 1 |
| 66439 | PH-1 | 5 | 100 | 105 | 8 | |
| 66440 | PH-2 | 6 | 125 | 115 | 6 | |
| 66441 | PH-3 | 8 | 150 | 128 | | |
| 66442 | PH-4 | 10 | 200 | 128 | 6 | |



| COD | | | | | | |
|-------|------|-----|-----|----|----|---|
| 66444 | PH-1 | 100 | 105 | 5 | 8 | 1 |
| 66445 | PH-2 | 125 | 115 | 6 | 11 | |
| 66446 | PH-3 | 150 | 128 | 8 | | |
| 66447 | PH-4 | 200 | 128 | 10 | 16 | |









| COD | | | | | | |
|-------|------|-----|---|-----|----|---|
| 66450 | PH-0 | 60 | 3 | 83 | 16 | 1 |
| 66451 | PH-1 | 80 | 5 | 105 | 8 | |
| 66452 | PH-2 | 100 | 6 | 115 | 6 | |
| 66453 | PH-3 | 125 | 7 | 128 | | |
| 66454 | PH-4 | 150 | 8 | 128 | 6 | |









9

DESTORNILLADORES / SCREWDRIVERS / TOURNEVIS / SCHRAUBENDREHER CACCIAVITI / SCHROEVENDRAAIER / CHAVES DE FENDA







POZIDRIV

| COD |  |  |  |  |  |  |
|-------|---|---|---|---|---|---|
| 66456 | PZ-0 | 3 | 60 | 83 | 16 | 1 |
| 66457 | PZ-1 | 5 | 100 | 105 | 8 | |
| 66458 | PZ-2 | 6 | 125 | 115 | 6 | |
| 66459 | PZ-3 | 8 | 150 | 128 | | |
| 66460 | PZ-4 | 10 | 200 | | | |









| COD |  |  |  |  |  |  |
|-------|---|---|---|---|---|---|
| 66462 | PZ-1 | 100 | 105 | 5 | 8 | 1 |
| 66463 | PZ-2 | 125 | 115 | 6 | 11 | |
| 66464 | PZ-3 | 150 | 128 | 8 | 6 | |
| 66465 | PZ-4 | 200 | | 10 | | |



| COD |  |  |  |  |  |  |
|-------|---|---|---|---|---|---|
| 66467 | PZ-0 | 3 | 60 | 83 | 16 | 1 |
| 66468 | PZ-1 | 5 | 100 | 105 | 8 | |
| 66469 | PZ-2 | 6 | 125 | 115 | 6 | |
| 66470 | PZ-3 | 8 | 150 | 128 | | |
| 66471 | PZ-4 | 10 | 200 | | | |









TORX

| COD |  |  |  |  |  |  |
|-------|---|---|---|---|---|---|
| 66474 | T-6 | 3 | 50 | 83 | 16 | 1 |
| 66475 | T-7 | | | | | |
| 66476 | T-8 | | | | | |
| 66477 | T-9 | 4 | 75 | 105 | 8 | |
| 66478 | T-10 | | | | | |
| 66479 | T-15 | 5 | 100 | 128 | 6 | |
| 66480 | T-20 | | | | | |
| 66481 | T-25 | | | | | |
| 66482 | T-27 | 6 | 115 | 105 | 8 | |
| 66483 | T-30 | | | | | |
| 66484 | T-40 | 7 | 125 | 128 | 6 | |
| 66485 | T-45 | 8 | 150 | | | |
| 66486 | T-50 | 10 | 175 | | | |









TAMPER TORX

| COD |  |  |  |  |  |  |
|-------|---|---|---|---|---|---|
| 66488 | TT-7 | 3 | 50 | 83 | 16 | 1 |
| 66489 | TT-8 | | | | | |
| 66490 | TT-9 | | | | | |
| 66491 | TT-10 | 4 | 75 | 105 | 8 | |
| 66492 | TT-15 | | | | | |
| 66493 | TT-20 | 5 | 100 | 128 | 6 | |
| 66494 | TT-25 | | | | | |
| 66495 | TT-27 | | | | | |
| 66496 | TT-30 | 6 | 115 | 105 | 8 | |
| 66497 | TT-40 | 7 | 125 | | | |
| 66498 | TT-45 | 8 | 150 | 128 | 6 | |
| 66499 | TT-50 | 10 | 175 | | | |



PUNTA ESFERA / BALL TIP / TETE SPHERIQUE / KUGELKOPF / TESTA SFERICA / KOGELKOP SCHROEVENDRAAIER / PONTA ESFERICA

| COD |  |  |  |  |  |  |
|-------|---|---|---|---|---|---|
| 66501 | 2,5 | 75 | 83 | 16 | 1 | |
| 66502 | 3 | | | | | |
| 66503 | 4 | 100 | 105 | 8 | | |
| 66504 | 5 | | | | | |
| 66505 | 6 | | | | | |
| 66506 | 8 | 150 | 128 | 6 | | |
| 66507 | 10 | | | | | |



9 DESTORNILLADORES / SCREWDRIVERS / TOURNEVIS / SCHRAUBENDREHER CACCIAVITI / SCHROEVENDRAAIER / CHAVES DE FENDA



ROBERTSON

| COD | | | | | | |
|-------|---|---|-----|-----|----|---|
| 66530 | 1 | 4 | 100 | 83 | 16 | 1 |
| 66531 | 2 | 5 | 125 | 105 | 8 | |
| 66532 | 3 | 6 | 150 | 128 | 6 | |



CARROCERO / STUBBY / TOM POUCE / SCHRAUBENDREHER, KURZE FORM / CACCIAVITI NANI / KORT GEDRONGEN UITVOERING / COTOS

| COD | | | | | | | |
|-------|-----|------|-----|----|----|----|---|
| 66525 | 1,2 | - | 5,5 | 25 | 62 | 20 | 1 |
| 66526 | - | PH-2 | 6 | | | | |



DIN 5265

| COD | | | | | | | |
|-------|------|---|----|----|----|---|--|
| 66527 | PZ-2 | 6 | 25 | 62 | 20 | 1 | |



DIN 5262

DE VASO / SOCKET SCREWDRIVER / CLE A DOUILLE EMMANCHEE / 6-KANT STECKSCHLÜSSEL / 6-KANT SLEUTEL / BUSSOLE / DE CAIXA

| COD | | | | | | |
|-------|-----|---|-----|-----|---|---|
| 66510 | 4 | 5 | 150 | 105 | 8 | 1 |
| 66511 | 5 | | | | | |
| 66512 | 5,5 | | | | | |
| 66513 | 6 | 6 | 160 | 115 | | |
| 66514 | 7 | | | | | |
| 66515 | 8 | 8 | 175 | 128 | 6 | |
| 66516 | 9 | | | | | |
| 66517 | 10 | | | | | |
| 66518 | 11 | 9 | | | | |
| 66519 | 12 | | | | | |
| 66520 | 13 | | | | | |
| 66521 | 14 | | | | | |



T - MASTERTORK

HEXAGONAL ALLEN

| COD | | | | | |
|-------|-----|--------|--------|----|---|
| 66571 | 2,5 | 125x15 | 60x39 | 16 | 1 |
| 66572 | 3 | | | | |
| 66573 | 4 | | | | |
| 66574 | 5 | 150x20 | 80x52 | 8 | |
| 66575 | 6 | | | | |
| 66576 | 8 | 175x25 | 100x65 | 6 | |
| 66577 | 10 | | | | |



TORX

| COD | | | | | |
|-------|------|--------|--------|----|---|
| 66581 | T-6 | 125x15 | 60x39 | 16 | 1 |
| 66582 | T-7 | | | | |
| 66583 | T-8 | | | | |
| 66584 | T-9 | | | | |
| 66585 | T-10 | | | | |
| 66586 | T-15 | 150x20 | 80x52 | 8 | |
| 66587 | T-20 | | | | |
| 66588 | T-25 | | | | |
| 66589 | T-27 | 175x25 | 100x65 | 6 | |
| 66590 | T-30 | | | | |
| 66591 | T-40 | | | | |
| 66592 | T-45 | | | | |
| 66593 | T-50 | | | | |



DE VASO / SOCKET SCREWDRIVER / CLE A DOUILLE EMMANCHEE / 6-KANT STECKSCHLÜSSEL / 6-KANT SLEUTEL / BUSSOLE / DE CAIXA

| COD | | | | | |
|-------|----|-----|--------|---|---|
| 66596 | 5 | 150 | 80x52 | 8 | 1 |
| 66597 | 6 | 160 | | | |
| 66598 | 7 | | | | |
| 66599 | 8 | 175 | 100x65 | 6 | |
| 66600 | 9 | | | | |
| 66601 | 10 | | | | |
| 66602 | 11 | | | | |
| 66603 | 12 | | | | |
| 66604 | 13 | | | | |



9

DESTORNILLADORES / SCREWDRIVERS / TOURNEVIS / SCHRAUBENDREHER CACCIAVITI / SCHROEVENDRAAIER / CHAVES DE FENDA

MASTERPUNCH ALL THROUGH



- SISTEMA DE PUNTA ANTIDESLIZANTE **NON-SLIP** Y MAGNETICA
- **NON-SLIP** ANTISLIPPERY MAGNETIC TIP
- **NON-SLIP** POINTE BRUNIE ANTIDÉRAPANTE ET MAGNETIQUE
- **NON-SLIP** ANTI-RUTSCH-SPITZE

- PUNTA ANTISCIVOLO **NON-SLIP**
- **NON-SLIP** ANTI SLIP TIP
- SISTEMA DE PUNTA ANTIDESLIZANTE DE CHAVE **NON-SLIP**

MECANICO / SLOTTED / MECANICIEN / MECHANIK / PER MECCANICI / SCHROEVENDAAIER VOOR SLEUFSCHROEVEN / MECÂNICO

| COD | | | | | | | | |
|-------|-----|-----|-----|-----|---|----|---|---|
| 66551 | 6,5 | 125 | 1,2 | 110 | 6 | 11 | 6 | 1 |
| 66552 | 8 | 150 | | 120 | 8 | | | |
| 66553 | 10 | 175 | 1,6 | | | | | |



PHILIPS

| COD | | | | | | | |
|-------|------|---|-----|-----|----|---|---|
| 66559 | PH-2 | 6 | 125 | 110 | 11 | 6 | 1 |
| 66560 | PH-3 | 8 | 150 | 120 | | | |



POZIDRIV

| COD | | | | | | | |
|-------|------|---|-----|-----|----|---|---|
| 66565 | PZ-2 | 6 | 125 | 110 | 11 | 6 | 1 |
| 66566 | PZ-3 | 8 | 150 | 120 | | | |



ROTORK

MECANICO / SLOTTED / MECANICIEN / MECHANIK / PER MECCANICI / SCHROEVENDAAIER VOOR SLEUFSCHROEVEN / MECÂNICO

| COD | | | | | | | |
|-------|-----|-----|-----|-----|----|---|--|
| 66874 | 3 | 0,5 | 80 | 100 | 16 | 1 | |
| 66875 | 4 | 0,8 | | | | | |
| 66876 | 5,5 | 1 | 100 | 105 | 8 | | |
| 66877 | | | 125 | | | | |
| 66878 | 6,5 | 1,2 | 150 | 110 | 6 | | |
| 66879 | 8 | | | | | | |
| 66880 | | | | | | | |
| 66881 | 10 | 1,6 | 200 | | | | |
| 66882 | | | | | | | |



| COD | | | | | | | |
|-------|-----|-----|-----|-----|----|---|---|
| 66883 | 6,5 | 1,2 | 125 | 110 | 10 | 6 | 1 |
| 66884 | 8 | | 150 | | 12 | | |
| 66885 | 10 | | 200 | | | | |



9 DESTORNILLADORES / SCREWDRIVERS / TOURNEVIS / SCHRAUBENDREHER CACCIAVITI / SCHROEVENDRAAIER / CHAVES DE FENDA



ELECTRICISTA / ELECTRICIAN / ELECTRICIEN / ELEKTRIK / SCHROEVENDRAAIER VOOR SLEUFSCHROEVEN MODEL ELEKTRICIEN
PER ELETTRICISTI / ELETRECISTA

| COD | | | | | | | |
|-------|---|-----|-----|--|-----|----|---|
| 66886 | | 0,4 | 60 | | | | |
| 66887 | 3 | 0,5 | 100 | | 100 | 16 | |
| 66888 | | 0,8 | 125 | | | | 1 |
| 66889 | 4 | | 150 | | | | |
| 66890 | | 1 | | | 105 | 8 | |
| 66891 | 5 | | 200 | | | | |
| 66892 | | 1,2 | 150 | | 110 | 6 | |



| COD | | | | | | | |
|-------|---|-----|-----|--|-----|----|---|
| 66893 | 3 | 0,5 | 100 | | 100 | 16 | |
| 66894 | | 0,8 | 125 | | | | 1 |
| 66895 | 5 | 1 | | | 105 | 8 | |
| 66896 | | 1,2 | 150 | | 110 | 6 | |



PHILIPS

| COD | | | | | | | |
|-------|---|------|-----|--|-----|----|---|
| 66897 | 3 | PH-0 | 60 | | 100 | 16 | |
| 66898 | | PH-1 | 100 | | 105 | 8 | 1 |
| 66899 | 6 | PH-2 | 125 | | | | |
| 66900 | | PH-3 | 150 | | 110 | 6 | |



| COD | | | | | | | |
|-------|---|------|-----|-----|----|---|---|
| 66901 | 6 | PH-2 | 125 | 105 | 10 | 8 | 1 |
| 66902 | | PH-3 | 150 | 110 | 12 | 6 | |



| COD | | | | | | | |
|-------|---|------|-----|--|-----|----|---|
| 66903 | 3 | PH-0 | 60 | | 100 | 16 | |
| 66904 | | PH-1 | 100 | | 105 | 8 | 1 |
| 66905 | 6 | PH-2 | 125 | | | | |
| 66906 | | PH-3 | 150 | | 110 | 6 | |



POZIDRIV

| COD | | | | | | | |
|-------|---|------|-----|--|-----|----|---|
| 66907 | 3 | PZ-0 | 60 | | 100 | 16 | |
| 66908 | | PZ-1 | 100 | | 105 | 8 | 1 |
| 66909 | 6 | PZ-2 | 125 | | | | |
| 66910 | | PZ-3 | 150 | | 110 | 6 | |



| COD | | | | | | | |
|-------|---|------|-----|-----|----|---|---|
| 66911 | 6 | PZ-2 | 125 | 105 | 10 | 8 | 1 |
| 66912 | | PZ-3 | 150 | 110 | 12 | 6 | |









| COD | | | | | | | |
|-------|---|------|-----|--|-----|----|---|
| 66913 | 3 | PZ-0 | 60 | | 100 | 16 | |
| 66914 | | PZ-1 | 100 | | 105 | 8 | 1 |
| 66915 | 6 | PZ-2 | 125 | | | | |
| 66916 | | PZ-3 | 150 | | 110 | 6 | |



9







DESTORNILLADORES / SCREWDRIVERS / TOURNEVIS / SCHRAUBENDREHER CACCIAVITI / SCHROEVENDRAAIER / CHAVES DE FENDA

TORX

| COD |  |  |  |  |  |  |
|-------|---|---|---|---|---|---|
| 66917 | | T-6 | | | | |
| 66918 | 50 | T-7 | 50 | | | |
| 66919 | | T-8 | | | | |
| 66920 | | T-9 | | 100 | 16 | |
| 66921 | 75 | T-10 | 75 | | | |
| 66922 | | T-15 | | | | 1 |
| 66923 | | T-20 | | | | |
| 66924 | 100 | T-25 | 100 | | | |
| 66925 | 115 | T-27 | 115 | 105 | 8 | |
| 66926 | | T-30 | | | | |
| 66927 | 125 | T-40 | 125 | 110 | 6 | |









PUNTA ESFERA / BALL TIP / TETE SPHERIQUE / KUGELKOPF / TESTA SFERICA / KOGELKOP SCHROEVENDRAAIER / PONTA ESFERICA

| COD |  |  |  |  |  |  |
|-------|---|---|---|---|---|---|
| 66928 | | 2,5 | | | | |
| 66929 | 75 | 3 | 100 | | 16 | |
| 66930 | | 4 | | | | 1 |
| 66931 | 100 | 5 | | | | |
| 66932 | 125 | 6 | 105 | | 8 | |
| 66933 | 150 | 8 | 110 | | 6 | |





ROBERTSON

| COD |  |  |  |  |  |  |
|-------|---|---|---|---|---|---|
| 66934 | | 4 | 100 | 100 | 16 | |
| 66935 | 5 | 5 | 125 | 105 | 8 | 1 |
| 66936 | 6 | 6 | 150 | 110 | 6 | |









CARROCERO / STUBBY / TOM POUCE / SCHRAUBENDREHER, KURZE FORM / CACCIAVITI NANI / KORT GEDRONGEN UITVOERING / COTOS

| COD |  |  |  |  |  |  |
|-------|---|---|---|---|---|---|
| 66937 | 6 | 25 | 1,2 | 60 | 20 | 1 |



DIN 5265

| COD |  |  |  |  |  |  |  |
|-------|---|---|---|---|---|---|---|
| 66938 | 5,5 | PH-2 | - | 25 | 60 | 20 | 1 |
| 66939 | 6 | - | PZ-2 | | | | |



DIN 5265

MICROTRONIC

 ELECTRICISTA / ELECTRICIAN / ELECTRICIEN / ELEKTRIK / SCHROEVENDRAAIER VOOR SLEUFSCHROEVEN MODEL ELEKTRICIEN
 PER ELETTRICISTI / ELETRICISTA

| COD | | | | | | |
|-------|---|------|----|----|----|---|
| 66846 | | | 50 | | | |
| 66847 | 2 | 0,40 | | 93 | 10 | 1 |
| 66848 | 3 | 0,50 | 75 | | | |
| 66849 | 4 | 0,80 | | | | |



DIN 6265

PHILIPS

| COD | | | | | | |
|-------|---|-------|----|----|----|---|
| 66850 | 2 | PH-00 | 50 | | | |
| 66851 | 3 | PH-0 | | 93 | 10 | 1 |
| 66852 | 4 | PH-1 | 75 | | | |



DIN 6262

POZIDRIV

| COD | | | | | | |
|-------|---|------|----|----|----|---|
| 66853 | 3 | PZ-0 | 50 | | | |
| 66854 | 4 | PZ-1 | 75 | 93 | 10 | 1 |



DIN 6262

TORX

| COD | | | | | | |
|-------|---|------|----|----|----|---|
| 66855 | 2 | T-6 | | | | |
| 66856 | | T-7 | 50 | | | |
| 66857 | | T-8 | | | | |
| 66858 | 3 | T-9 | | 93 | 10 | 1 |
| 66859 | | T-10 | 75 | | | |
| 66860 | | T-15 | | | | |
| 66861 | 4 | T-20 | | | | |

TAMPER TORX

| COD | | | | | | |
|-------|---|-------|----|----|----|---|
| 66866 | 2 | TT-6 | | | | |
| 66867 | | TT-7 | 50 | | | |
| 66868 | | TT-8 | | | | |
| 66869 | 3 | TT-9 | | 93 | 10 | 1 |
| 66870 | | TT-10 | 75 | | | |
| 66871 | | TT-15 | | | | |
| 66872 | 4 | TT-20 | | | | |

 HEXAGONAL PUNTA ESFERA / HEXAGONAL BALL POINT / HEXAGONALE AVEC EMBOUT SPHERIQUE / HEXAGONAL KUGELKOPF /
 HEXAGONAL TESTA ESFERICA / HEX KOGELKOP / HEXAGONAL COM PONTA ESFERICA

| COD | | | | | |
|-------|----|-----|----|----|---|
| 66862 | | 1,5 | | | |
| 66863 | | 2 | | | |
| 66864 | 50 | 2,5 | 93 | 10 | 1 |
| 66865 | 60 | 3 | | | |

 MAGNETIZADOR-DESMAGNETIZADOR / MAGNETIZER-DEMAGNETIZER / MAGNETISEUR-DEMAGNETISEUR
 MAGNETISIER-ENTMAGNETISIERGERÄT / MAGNETIZZATORE- SMAGNETIZZATORE
 MAGNETISSERAPPARAAT-MAGNETISEERAPPARAAT

| COD | | | |
|-------|----|----|---|
| 69504 | 80 | 12 | 1 |



EXPOSITORES Y SETS / DISPLAYS AND SETS / PRESENTOIRS ET SETS / STÄNDER /
ESPOSITORE / DISPLAY STAND

mastertork

150 PCS.

PCS. **COD:66540**

| | | | |
|----|-------|---------|---|
| 10 | 66402 | 5,5x100 | |
| 10 | 66404 | 6,5x125 | |
| 10 | 66406 | 8x150 | Ⓢ |
| 10 | 66421 | 3x60 | Ⓢ |
| 10 | 66422 | 3X100 | |
| 10 | 66423 | 4x125 | |
| 10 | 66425 | 5,5x150 | |
| 10 | 66426 | 6,5X150 | |
| 10 | 66430 | 3X100 | Ⓢ |
| 10 | 66438 | PH-0 | |
| 10 | 66439 | PH-1 | + |
| 10 | 66440 | PH-2 | |
| 10 | 66456 | PZ-0 | |
| 10 | 66457 | PZ-1 | + |
| 10 | 66458 | PZ-2 | |



56 PCS.

PCS. **COD:66541**

| | | | |
|---|-------|---------|---|
| 6 | 66402 | 5,5x100 | |
| 5 | 66404 | 6,5x125 | |
| 5 | 66406 | 8x150 | Ⓢ |
| 6 | 66423 | 4x125 | |
| 6 | 66425 | 5,5X150 | |
| 6 | 66431 | 4X125 | Ⓢ |
| 6 | 66439 | PH-1 | + |
| 5 | 66440 | PH-2 | |
| 6 | 66457 | PZ-1 | + |
| 5 | 66458 | PZ-2 | |



B



C



5 PCS.

PCS.

| | | | |
|---|-------|---------|---|
| 1 | 66403 | 5,5x125 | |
| 1 | 66422 | 3x100 | Ⓢ |
| 1 | 66425 | 5,5x150 | |
| 1 | 66439 | PH-1 | + |
| 1 | 66440 | PH-2 | |

COD A: 69909
COD B: 69858
COD C: 68487

6 PCS.

PCS.

| | | | |
|---|-------|---------|---|
| 1 | 66421 | 3x60 | |
| 1 | 66422 | 3x100 | Ⓢ |
| 1 | 66425 | 5,5x150 | |
| 1 | 66430 | 3X100 | Ⓢ |
| 1 | 66439 | PH-1 | + |
| 1 | 66440 | PH-2 | |

COD A: 69910
COD B: 69859
COD C: 68488

8 PCS.

PCS.

| | | | |
|---|-------|---------|---|
| 1 | 66422 | 3x100 | |
| 1 | 66423 | 4x125 | Ⓢ |
| 1 | 66403 | 5,5x125 | |
| 1 | 66405 | 6,5x150 | |
| 1 | 66438 | PH-0 | + |
| 1 | 66439 | PH-1 | + |
| 1 | 66457 | PZ-1 | + |
| 1 | 66458 | PZ-2 | + |

COD A: 69911
COD B: 69860
COD C: 68489

1000V 4 PCS.

PCS.

| | | | |
|---|-------|------|---|
| 1 | 66467 | PZ-0 | |
| 1 | 66468 | PZ-1 | + |
| 1 | 66469 | PZ-2 | |
| 1 | 66470 | PZ-3 | |

COD A: 69926
COD B: 69895
COD C: 68490

1000V 5 PCS.

PCS.

| | | | |
|---|-------|---------|---|
| 1 | 66430 | 3x100 | |
| 1 | 66431 | 4x125 | |
| 1 | 66432 | 5,5x150 | Ⓢ |
| 1 | 66433 | 6,5x150 | |
| 1 | 66434 | 8x175 | |

COD A: 69928
COD B: 69897
COD C: 68492

1000V 6 PCS.

PCS.

| | | | |
|---|-------|---------|---|
| 1 | 66430 | 3x100 | |
| 1 | 66431 | 4x125 | |
| 1 | 66432 | 5,5x150 | Ⓢ |
| 1 | 66433 | 6,5x150 | |
| 1 | 66434 | 8x175 | |
| 1 | 66435 | 10x200 | |

COD A: 69925
COD B: 69894
COD C: 68493

1000V 8 PCS.

PCS.

| | | | |
|---|-------|---------|---|
| 1 | 66430 | 3x100 | |
| 1 | 66431 | 4x125 | Ⓢ |
| 1 | 66432 | 5,5x150 | Ⓢ |
| 1 | 66433 | 6,5x150 | |
| 1 | 66451 | PH-1 | + |
| 1 | 66452 | PH-2 | + |
| 1 | 66468 | PZ-1 | + |
| 1 | 66469 | PZ-2 | + |

COD A: 69932
COD B: 69931
COD C: 68494

1000V 4 PCS.

PCS.

| | | | |
|---|-------|------|---|
| 1 | 66450 | PH-0 | |
| 1 | 66451 | PH-1 | + |
| 1 | 66452 | PH-2 | |
| 1 | 66453 | PH-3 | |

COD A: 69927
COD B: 69896
COD C: 68491

rotork

150 PCS.
PCS. **COD:66992**

| | | | |
|----|--------------|---------|---|
| 10 | 66876 | 5,5x100 | |
| 10 | 66878 | 6,5x125 | |
| 10 | 66880 | 8x150 | |
| 10 | 66886 | 3x60 | ⓪ |
| 10 | 66887 | 3X100 | ⓪ |
| 10 | 66888 | 4x125 | |
| 10 | 66890 | 5x150 | |
| 10 | 66892 | 6X150 | |
| 10 | 66893 | 3X100 | ⓪ |
| 10 | 66897 | PH-0 | ⊕ |
| 10 | 66898 | PH-1 | ⊕ |
| 10 | 66899 | PH-2 | ⊕ |
| 10 | 66907 | PZ-0 | |
| 10 | 66908 | PZ-1 | ⊕ |
| 10 | 66909 | PZ-2 | ⊕ |



60 PCS.
PCS. **COD:66993**

| | | | |
|---|--------------|---------|---|
| 6 | 66876 | 5,5x100 | |
| 5 | 66878 | 6,5x125 | |
| 5 | 66880 | 8x150 | |
| 7 | 66887 | 3x100 | ⓪ |
| 7 | 66888 | 4x125 | |
| 6 | 66890 | 5x150 | |
| 6 | 66898 | PH-1 | ⊕ |
| 6 | 66899 | PH-2 | ⊕ |
| 6 | 66908 | PZ-1 | ⊕ |
| 6 | 66909 | PZ-2 | ⊕ |



5 PCS.
PCS. **COD A: 69912**
COD B: 66995
COD C: 68495

| | | | |
|---|--------------|---------|---|
| 1 | 66877 | 5,5x125 | ⓪ |
| 1 | 66887 | 3x100 | ⓪ |
| 1 | 66890 | 5x150 | |
| 1 | 66898 | PH-1 | ⊕ |
| 1 | 66899 | PH-2 | ⊕ |

6 PCS.
PCS. **COD A: 69913**
COD B: 66996
COD C: 68496

| | | | |
|---|--------------|-------|---|
| 1 | 66886 | 3x60 | |
| 1 | 66887 | 3x100 | ⓪ |
| 1 | 66890 | 5x150 | ⓪ |
| 1 | 66893 | 3X100 | ⓪ |
| 1 | 66898 | PH-1 | ⊕ |
| 1 | 66899 | PH-2 | ⊕ |

8 PCS.
PCS. **COD A: 69914**
COD B: 66997
COD C: 68497

| | | | |
|---|--------------|---------|---|
| 1 | 66887 | 3x100 | |
| 1 | 66888 | 4x125 | ⓪ |
| 1 | 66877 | 5,5x125 | ⓪ |
| 1 | 66879 | 6,5x150 | |
| 1 | 66897 | PH-0 | ⊕ |
| 1 | 66898 | PH-1 | ⊕ |
| 1 | 66908 | PZ-1 | ⊕ |
| 1 | 66909 | PZ-2 | ⊕ |

1000V 6 PCS.
PCS. **COD A: 69930**
COD B: 69929
COD C: 68498

| | | | |
|---|--------------|-------|---|
| 1 | 66893 | 3x100 | ⓪ |
| 1 | 66894 | 4x125 | ⓪ |
| 1 | 66895 | 5x150 | |
| 1 | 66903 | PH-0 | ⊕ |
| 1 | 66904 | PH-1 | ⊕ |
| 1 | 66905 | PH-2 | ⊕ |

1000V 8 PCS.
PCS. **COD A: 69915**
COD B: 66998
COD C: 68499

| | | | |
|---|--------------|-------|---|
| 1 | 66893 | 3x100 | ⓪ |
| 1 | 66894 | 4x125 | ⓪ |
| 1 | 66895 | 5x150 | |
| 1 | 66896 | 6x150 | |
| 1 | 66904 | PH-1 | ⊕ |
| 1 | 66905 | PH-2 | ⊕ |
| 1 | 66914 | PZ-1 | ⊕ |
| 1 | 66915 | PZ-2 | ⊕ |

**EXPOSITORES Y SETS / DISPLAYS AND SETS / PRESENTOIRS ET SETS / STÄNDER /
ESPOSITORE / DISPLAY STAND**
microtronic

MICROTRONIC 100 PCS.
PCS. COD:66994

| | | | |
|---|-------|--------|---|
| 5 | 66846 | 2x50 | |
| 5 | 66847 | 2x75 | ⓪ |
| 5 | 66848 | 3x75 | ⓪ |
| 5 | 66849 | 4x75 | |
| 5 | 66850 | PH-00 | |
| 5 | 66851 | PH-0 | ⊕ |
| 5 | 66852 | PH-1 | |
| 5 | 66853 | PZ-0 | ⊕ |
| 5 | 66854 | PZ-1 | ⊕ |
| 5 | 66855 | T-6 | |
| 5 | 66856 | T-7 | |
| 5 | 66857 | T-8 | |
| 5 | 66858 | T-9 | ⊛ |
| 5 | 66859 | T-10 | |
| 5 | 66860 | T-15 | |
| 5 | 66861 | T-20 | |
| 5 | 66862 | 1,5x50 | |
| 5 | 66863 | 2x50 | ⬡ |
| 5 | 66864 | 2,5x50 | |
| 5 | 66865 | 3x60 | |

MICROTRONIC 100 PCS.
PCS. COD:66990

| | | | |
|---|-------|--------|---|
| 5 | 66846 | 2x50 | |
| 5 | 66847 | 2x75 | ⓪ |
| 5 | 66848 | 3x75 | ⓪ |
| 5 | 66849 | 4x75 | |
| 5 | 66850 | PH-00 | |
| 5 | 66851 | PH-0 | ⊕ |
| 5 | 66852 | PH-1 | |
| 5 | 66853 | PZ-0 | ⊕ |
| 5 | 66854 | PZ-1 | ⊕ |
| 5 | 66866 | TT-6 | |
| 5 | 66867 | TT-7 | |
| 5 | 66868 | TT-8 | ⊛ |
| 5 | 66869 | TT-9 | ⊛ |
| 5 | 66870 | TT-10 | |
| 5 | 66871 | TT-15 | |
| 5 | 66872 | TT-20 | |
| 5 | 66862 | 1,5x50 | |
| 5 | 66863 | 2x50 | ⬡ |
| 5 | 66864 | 2,5x50 | |
| 5 | 66865 | 3x60 | |

MICROTRONIC 6 PCS.
PCS. COD:66999

| | | | |
|---|-------|-------|---|
| 1 | 66846 | 2x50 | ⓪ |
| 1 | 66848 | 3x75 | ⓪ |
| 1 | 66850 | PH-00 | |
| 1 | 66851 | PH-0 | ⊕ |
| 1 | 66853 | PZ-0 | ⊕ |
| 1 | 66854 | PZ-1 | ⊕ |

MICROTRONIC 8 PCS.
PCS. COD:69496

| | | | |
|---|-------|-------|---|
| 1 | 69530 | | |
| 1 | 62526 | | |
| 1 | 62527 | | |
| 1 | 62528 | | |
| 1 | 62529 | | |
| 1 | 62531 | | |
| 1 | 66846 | 2x50 | ⓪ |
| 1 | 66850 | PH-00 | ⊕ |



*PUNTAS DE DESTORNILLADOR / BITS / POINTES DE TOURNEVIS / BITS
INSERTI / BITSEN / PONTAS*

masterbit

- Alta calidad de material, Cr-Mo-V, que permite alcanzar altas durezas manteniendo la tenacidad
- Alta dureza, con la consiguiente resistencia al desgaste: 56-60HRC
- Alta precisión de acabado
- High quality material, Cr-Mo-V, enables the bit to achieve high hardness while maintaining the tenacity
- High hardness, provides strong resistance to wearing: 56-60HRC
- High finishing accuracy
- Matériel de grande qualité, Cr-Mo-V, qui permet d'atteindre des hautes duretés tout en gardant la tenacité
- Grande dureté, résultant une résistance à l'usure : 56-60 HRC
- Une finition de grande précision

**masterbit torsion**

- Alta calidad de material, Cr-Mo-V, que permite alcanzar altas durezas manteniendo la tenacidad
- Alta dureza, con la consiguiente resistencia al desgaste: 58-62HRC
- Alta precisión de acabado
- Buen acceso a espacios reducidos de atornillado/desatornillado
- La zona especial de torsión amortigua el esfuerzo final de atornillado
- Se alarga la vida de la punta y del atornillador gracias a la potencia de torsión
- High quality material, Cr-Mo-V, enables the bit to achieve high hardness while maintaining the tenacity
- High hardness, provides strong resistance to wearing: 58-62HRC
- High finishing accuracy
- Good access to confined spaces for screwing/unscrewing
- The special zone for torsion cushions the final effort of screwing
- The life of the bit and the screwdriver is longer due to the torsion power
- Matériel de grande qualité, Cr-Mo-V, qui permet d'atteindre des hautes duretés tout en gardant la tenacité
- Grande dureté, résultant une résistance à l'usure : 56-60 HRC
- Une finition de grande précision
- Bonne accessibilité à des espaces réduits pour visser et dévisser
- La zone spéciale de torsion amortit la force finale de vissage
- La durée de vie de l'embout et du porte embout est améliorée grâce à la capacité de torsion

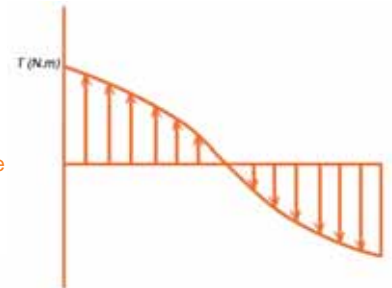
**masterbit non-slip**

- Alta calidad de material, Cr-Mo-V, que permite alcanzar altas durezas manteniendo la tenacidad
- Alta dureza, con la consiguiente resistencia al desgaste: 58-62HRC
- Alta precisión de acabado
- Especialmente diseñada para disminuir el efecto de expulsión en el atornillado fuerte
- Se alarga la vida de la punta y del atornillador gracias a la reducción del efecto expulsión
- High quality material, Cr-Mo-V, enables the bit to achieve high hardness while maintaining the tenacity
- High hardness, provides strong resistance to wearing: 58-62HRC
- High finishing accuracy
- Specially designed to avoid undesired slides
- The life of the bit and the screwdriver becomes longer due to the reduction of come out effect
- Matériel de grande qualité, Cr-Mo-V, qui permet d'atteindre des hautes duretés tout en gardant la tenacité
- Grande dureté, résultant une résistance à l'usure : 56-60 HRC
- Une finition de grande précision
- Spécialement conçue pour diminuer l'effet d'expulsion pour des vissages difficiles
- La durée de vie de l'embout et du porte-embout est supérieure grâce à la réduction de l'effet d'expulsion

**masterbit tin**

- Alta calidad de material, Cr-Mo-V, que permite alcanzar altas durezas manteniendo la tenacidad
- Alta dureza, con la consiguiente resistencia al desgaste: 58-62HRC
- Alta dureza superficial, con la consiguiente resistencia al desgaste: 2400Hv
- Alta precisión de acabado
- Puntas recubiertas de Nitruro de Titanio especialmente indicadas para trabajos repetitivos
- La vida de la punta se alarga de 4 a 10 veces
- Excelente resistencia antioxidante
- High quality material, Cr-Mo-V, enables the bit to achieve high hardness while maintaining the tenacity
- High hardness, provides strong resistance to wearing: 58-62HRC
- High superficial hardness, getting a extremely high resistance to wearing: 2400Hv
- High finishing accuracy
- Titan Nitride coated bits are specially suitable for repetitive works
- The life of the bit becomes up to 10 times longer
- Excellent anti-rust protection
- Matériel de grande qualité, Cr-Mo-V, qui permet d'atteindre des hautes duretés tout en gardant la tenacité
- Grande dureté, résultant une résistance à l'usure : 56-60 HRC
- Grande dureté superficielle, avec la résistance à l'usure acquise de: 2400Hv
- Une finition de grande précision
- Embouts recouverts de triniture de titane, spécialement indiqué pour des travaux répétitifs
- La durée de vie de l'embout est 4 à 10 fois supérieure
- Excellente résistance à l'oxidation



DESTORNILLADORES PORTAPUNTAS / BITHOLDER SCREWDRIVERS / TOURNEVIS PORTE-EMBOUTS BITHALTER SCHRAUBENDREHER / CACCIAVITE PORTA INSERTI / BITHOUDER SCHROEVENDRAAIER CHAVE PORTA PONTAS

DESTORNILLADOR PORTAPUNTAS MAGNÉTICO / MAGNETIC BITHOLDER SCREWDRIVER / TOURNEVIS PORTE-EMBOUTS MAGNÉTIQUE MAGNETISCHE BITHALTER SCHRAUBENDREHER / CACCIAVITE PORTA INSERTI MAGNETICO MAGNETISCHE SCHROEVENDRAAIER BITHOUDER / CHAVE PORTA PONTAS MAGNETICO

| | | | | | |
|------------|------|-----|-----|---|---|
| COD | | | | | |
| 66731 | 1/4" | 215 | 105 | 6 | 1 |



DESTORNILLADOR PORTAPUNTAS MAGNÉTICO CON CARRACA / MAGNETIC BITHOLDER RATCHET SCREWDRIVER TOURNEVIS PORTE-EMBOUTS MAGNÉTIQUE À CLIQUET / MAGNETISCHE BILHALTERSCHRAUBENDREHER MIT RATSCHÉ CACCIAVITE PORTA INSERTI MAGNETICO A CRICCO / MAGNETISCHE SCHROEVENDRAAIER BITHOUDER MET VERSTELLING CHAVE PORTA PONTAS MAGNETICO COM ROQUETE

| | | | | | |
|------------|------|-----|-----|---|---|
| COD | | | | | |
| 66843 | 1/4" | 220 | 200 | 6 | 1 |



DESTORNILLADOR PORTAPUNTAS MAGNÉTICO CON VARILLA FLEXIBLE / MAGNETIC BITHOLDER SCREWDRIVER WITH FLEXIBLE BLADE TOURNEVIS PORTE-EMBOUTS MAGNÉTIQUE À LAME FLÉXIBLE / MAGNETISCHE BILHALTERSCHRAUBENDREHER FLEX BLATT CACCIAVITE PORTA INSERTI MAGNETICO ARTICOLATO / MAGNETISCHE SCHROEVENDRAAIER BIHOUDER FLEX CHAVE PORTA PONTAS MAGNETICO FLEXIBEL

| | | | | | |
|------------|------|-----------|-----|---|---|
| COD | | | | | |
| 66844 | 1/4" | 235 - 350 | 200 | 6 | 1 |



Carraca / Ratchet / Crécelle



DESTORNILLADOR DINAMOMÉTRICO / TORQUE SCREWDRIVER / TOURNEVIS DYNAMOMÉTRIQUE / DREHMOMENT SCHRAUBENDREHER / CACCIAVITE DINAMOMETRICO MOMENTSCHROEVENDRAAIER / CHAVE DE FENDAS DINAMOMÉTRICA

| | | | | | |
|------------|------|------------|--------|-----|---|
| COD | | N.m | | | |
| 66845 | 1/4" | 1 - 4 | 180 mm | 550 | 1 |

| PCS. | | COMPOSICION / COMPOSITION |
|------|----|-----------------------------------|
| 5 | 25 | 3, 4, 5, 6, 8 mm |
| 4 | | 3, 4, 5, 5, 6, 6, 7 mm |
| 4 | | PH0 - PH1 - PH2 - PH3 |
| 2 | | S1 - S2 - S3 - S4 |
| 6 | | PZ1 - PZ2 |
| 6 | | T10 - T15 - T20 - T25 - T30 - T40 |

| | | |
|--|------|----|
| | | |
| | 1/4" | 60 |
| | | 25 |



NEW



ATORNILLADOR ELÉCTRICO / CORDLESS SCREWDRIVER / TOURNEVIS ÉLECTRIQUE
 DRAHTLOSER SCHRAUBENDREHER / CACCAIVITE ELETTRICO
 DRAADLOSE SCHROEVENDRAAIER / APARAFUSADOR ELECTRICO

| COD |  | rpm | V | V | Bat. |  |  |
|-------|---|-----|----------|--------|--------|---|--|
| 66991 | 1/4" | 180 | 110-230V | 3,6 DC | Li-ion | 390 | 1 |

Especificaciones técnicas / Technical specification / Détails techniques

| | |
|---|--------|
| Max. potencia de transmisión Max. transmission power Max. Puissance de transmission | 3 N.m |
| rpm | 180 |
| Duracion bat / Bat. life / Durée Bat. | 45 min |
| Tiempo de carga / Charge / Temps de charge | 4 h |
| Reversible / Reversible / Réversible | ● |





| COD |  | rpm | V | V | Bat. |  |  |
|-------|---|-----|------|--------|-------|---|--|
| 66940 | 1/4" | 180 | 110V | 3,6 DC | Ni-Cd | 320 | 1 |
| 66957 | | | 230V | | | | |

Especificaciones técnicas / Technical specification / Détails techniques

| | |
|---|--------|
| Max. potencia de transmisión Max. transmission power Max. Puissance de transmission | 3 N.m |
| rpm | 180 |
| Duracion bat / Bat. life / Durée Bat. | 40 min |
| Tiempo de carga / Charge / Temps de charge | 4 h |
| Luz incorporada / With light / Lumière incorporée | ● |
| Reversible / Reversible / Réversible | ● |



DESTORNILLADOR ACCION RAPIDA / SPEED ACTION SCREWDRIVER / TOURNEVIS ACTION RAPIDE / SPEED ACTION SCHRAUBENDREHER / CACCAIVITE AZIONE RAPIDA
 SPEED ACTION SCHROEVENDRAAIER / CHAVE DE FENDAS ACÇÃO RÁPIDA

| COD | Velocidad Speed | Par Torque | Composición Composition |  |  |
|-------|--------------------|-----------------------|---|---|--|
| 66373 | 4:1 | Standard | HEX3, HEX4, HEX5 3X0'7, 4X1, 5X1'2 PH1, PH2, PH3 T15, T20, T25 | 400 | 2 |
| | 1:1 | Alto High Élevé | | | |



CARRACA / RATCHET / CRÉCELLE



VELOCIDADX4 / SPEEDX4 / VÉLOCITÉX4

"MASTERBIT"

PLANA / FLAT / PLATE / FLACH / PIATTA / SLEUF / PLANA

| COD | | | | PCS |
|-------|---------|----|--|-----|
| 66121 | 3x0,5 | 25 | | 5 |
| 66623 | 3x0,5 | | | 10 |
| 66122 | 4,5x0,6 | | | 5 |
| 66624 | 4,5x0,6 | | | 10 |
| 66123 | 5,5x0,8 | | | 5 |
| 66625 | 5,5x0,8 | | | 10 |
| 66124 | 5,5x1 | | | 5 |
| 66626 | 5,5x1 | | | 10 |
| 66125 | 6,5x1,2 | | | 5 |
| 66627 | 6,5x1,2 | | | 10 |
| 66126 | 8x1,6 | 5 | | |
| 66628 | 8x1,6 | 10 | | |



| COD | | | | PCS |
|-------|---------|----|--|-----|
| 66127 | 3x0,5 | 50 | | 5 |
| 66629 | 3x0,5 | | | 10 |
| 66128 | 3,5x0,6 | | | 5 |
| 66630 | 3,5x0,6 | | | 10 |
| 66129 | 4x0,8 | | | 5 |
| 66631 | 4x0,8 | | | 10 |
| 66130 | 5,5x1 | | | 5 |
| 66632 | 5,5x1 | | | 10 |
| 66131 | 6,5x1,2 | | | 5 |
| 66633 | 6,5x1,2 | | | 10 |
| 66132 | 8x1,6 | 5 | | |
| 66634 | 8x1,6 | 10 | | |



PHILIPS

| COD | | | | PCS |
|-------|------|----|--|-----|
| 66133 | PH-0 | 25 | | 5 |
| 66635 | PH-0 | | | 10 |
| 66134 | PH-1 | | | 5 |
| 66636 | PH-1 | | | 10 |
| 66135 | PH-2 | | | 5 |
| 66637 | PH-2 | | | 10 |
| 66136 | PH-3 | 30 | | 5 |
| 66638 | PH-3 | | | 10 |
| 66137 | PH-4 | | | 5 |
| 66639 | PH-4 | | | 10 |



POZIDRIV

| COD | | | | PCS |
|-------|------|----|--|-----|
| 66138 | PZ-0 | 25 | | 5 |
| 66640 | PZ-0 | | | 10 |
| 66139 | PZ-1 | | | 5 |
| 66641 | PZ-1 | | | 10 |
| 66140 | PZ-2 | | | 5 |
| 66642 | PZ-2 | | | 10 |
| 66141 | PZ-3 | 30 | | 5 |
| 66643 | PZ-3 | | | 10 |
| 66142 | PZ-4 | | | 5 |
| 66644 | PZ-4 | | | 10 |







Empaquetado en blister en 5/10 uds. / 5/10 pcs. blister packaging / Conditionnement Blister 5/10 pièces





NATO Commercial and Government Entity (NCAGE) Code / Código (NCAGE) OTAN: 8552B



HEXAGONAL / HEXAGONAL / HEXAGONALE / HEXAGONAL / ESANGONALO / HEX / HEXAGONAL





| COD |  |  |  | PCS | |
|-------|---|---|---|-----|----|
| 66144 | 25 | 25 |  | 5 | |
| 66645 | | | | 1,5 | 10 |
| 66145 | | | | 2 | 5 |
| 66646 | | | | 2 | 10 |
| 66146 | | | | 2,5 | 5 |
| 66647 | | | | 2,5 | 10 |
| 66147 | | | | 3 | 5 |
| 66648 | | | | 3 | 10 |
| 66148 | | | | 4 | 5 |
| 66649 | | | | 4 | 10 |
| 66149 | | | | 5 | 5 |
| 66650 | | | | 5 | 10 |
| 66172 | | | | 6 | 5 |
| 66651 | | | | 6 | 10 |
| 66173 | | | | 8 | 5 |
| 66652 | | | | 8 | 10 |



| COD |  |  |  | PCS | |
|-------|---|---|---|-----|----|
| 66174 | 50 | 50 |  | 5 | |
| 66653 | | | | 3 | 10 |
| 66175 | | | | 4 | 5 |
| 66654 | | | | 4 | 10 |
| 66176 | | | | 5 | 5 |
| 66655 | | | | 5 | 10 |
| 66177 | | | | 6 | 5 |
| 66656 | | | | 6 | 10 |
| 66178 | | | | 8 | 5 |
| 66657 | | | | 8 | 10 |







HEXAGONAL CON PUNTA DE BOLA / HEXAGONAL BALL POINT / HEXAGONALE EMBOUT SPHÉRIQUE / HEXAGONAL KUGELKOPF / ESANGONALO TESTA SFERICA / HEX KOGELKOP / HEXAGONAL COM PONTA ESFERICA

| COD |  |  |  | PCS | |
|-------|---|---|---|-----|----|
| 66179 | 50 | 50 |  | 5 | |
| 66658 | | | | 2 | 10 |
| 66180 | | | | 2,5 | 5 |
| 66659 | | | | 2,5 | 10 |
| 66181 | | | | 3 | 5 |
| 66660 | | | | 3 | 10 |
| 66182 | | | | 4 | 5 |
| 66661 | | | | 4 | 10 |
| 66183 | | | | 5 | 5 |
| 66662 | | | | 5 | 10 |
| 66184 | | | | 6 | 5 |
| 66663 | | | | 6 | 10 |



ROBERTSON

| COD |  |  |  | PCS | |
|-------|---|---|---|-----|----|
| 66384 | 25 | 25 |  | 5 | |
| 66690 | | | | S1 | 10 |
| 66385 | | | | S2 | 5 |
| 66691 | | | | S2 | 10 |
| 66386 | | | | S3 | 5 |
| 66692 | | | | S3 | 10 |
| 66387 | | | | S4 | 5 |
| 66693 | | | | S4 | 10 |



TORX

| COD | | | | PCS | |
|-------|------|----|--|-----|----|
| 66185 | T-5 | 25 | | 5 | |
| 66664 | | | | 10 | |
| 66186 | | | | T-6 | 5 |
| 66665 | | | | | 10 |
| 66187 | | | | T-7 | 5 |
| 66666 | | | | | 10 |
| 66188 | | | | T-8 | 5 |
| 66667 | | | | | 10 |
| 66189 | | | | T-9 | 5 |
| 66668 | | | | | 10 |
| 66190 | T-10 | 5 | | | |
| 66669 | | 10 | | | |
| 66191 | T-15 | 5 | | | |
| 66670 | | 10 | | | |
| 66192 | T-20 | 5 | | | |
| 66671 | | 10 | | | |
| 66193 | T-25 | 5 | | | |
| 66672 | | 10 | | | |
| 66194 | T-27 | 5 | | | |
| 66673 | | 10 | | | |
| 66195 | T-30 | 5 | | | |
| 66674 | | 10 | | | |
| 66196 | T-40 | 5 | | | |
| 66675 | | 10 | | | |



| COD | | | | PCS | |
|-------|------|----|--|------|----|
| 66241 | T-10 | 50 | | 5 | |
| 66676 | | | | 10 | |
| 66242 | | | | T-15 | 5 |
| 66677 | | | | | 10 |
| 66243 | | | | T-20 | 5 |
| 66678 | | | | | 10 |
| 66244 | | | | T-25 | 5 |
| 66679 | | | | | 10 |
| 66245 | | | | T-27 | 5 |
| 66680 | | | | | 10 |
| 66246 | T-30 | 5 | | | |
| 66681 | | 10 | | | |
| 66247 | T-40 | 5 | | | |
| 66682 | | 10 | | | |



TAMPER TORX

| COD | | | | PCS | |
|-------|-------|----|--|-------|----|
| 66392 | TT-10 | 25 | | 5 | |
| 66683 | | | | 10 | |
| 66393 | | | | TT-15 | 5 |
| 66684 | | | | | 10 |
| 66394 | | | | TT-20 | 5 |
| 66685 | | | | | 10 |
| 66395 | | | | TT-25 | 5 |
| 66686 | | | | | 10 |
| 66396 | | | | TT-27 | 5 |
| 66687 | | | | | 10 |
| 66397 | TT-30 | 5 | | | |
| 66688 | | 10 | | | |
| 66398 | TT-40 | 5 | | | |
| 66689 | | 10 | | | |







Empaquetado en blister en 5/10 uds. / 5/10 pcs. blister packaging / Conditionnement Blister 5/10 pièces

NATO Commercial and Government Entity (NCAGE) Code / Código (NCAGE) OTAN: 8552B







MAGNETIC STECKER

| COD |  |  |  |  |  |
|-------|---|---|---|---|---|
| 66269 | 5,5 | 65 | 35 | 10 | 1 |
| 66270 | 7 | | | | |
| 66271 | 8 | | | | |
| 66279 | 10 | | | | |
| 66280 | 13 | | | | |



 1/4"





XZN

| COD |  |  |  | PCS |
|-------|---|---|---|-----|
| 66966 | M4 | 25 |  | 5 |
| 66971 | M4 | | | 10 |
| 66967 | M5 | | | 5 |
| 66972 | M5 | | | 10 |
| 66968 | M6 | | | 5 |
| 66973 | M6 | | | 10 |
| 66969 | M8 | | | 5 |
| 66974 | M8 | | | 10 |
| 66970 | M10 | | | 5 |
| 66975 | M10 | | | 10 |



 1/4"





SPANNER

| COD |  |  |  | PCS |
|-------|--|--|--|-----|
| 66958 | 4 | 25 |  | 5 |
| 66962 | 4 | | | 10 |
| 66959 | 6 | | | 5 |
| 66963 | 6 | | | 10 |
| 66960 | 8 | | | 5 |
| 66964 | 8 | | | 10 |
| 66961 | 10 | | | 5 |
| 66965 | 10 | | | 10 |



 1/4"





TRI - WING ®

| COD |  |  |  | PCS |
|-------|---|---|---|-----|
| 66982 | 1 | 25 |  | 5 |
| 66986 | 1 | | | 10 |
| 66983 | 2 | | | 5 |
| 66987 | 2 | | | 10 |
| 66984 | 3 | | | 5 |
| 66988 | 3 | | | 10 |
| 66985 | 4 | | | 5 |
| 66989 | 4 | | | 10 |



 1/4"

TORQ - SET ®

| COD |  |  |  | PCS |
|-------|---|---|---|-----|
| 66976 | 6 | 25 |  | 5 |
| 66979 | 6 | | | 10 |
| 66977 | 8 | | | 5 |
| 66980 | 8 | | | 10 |
| 66978 | 10 | | | 5 |
| 66981 | 10 | | | 10 |



 1/4"



Empaquetado en blister en 5/10 uds. (excepto stecker) / 5/10 pcs. blister packaging (except stecker) / Conditionnement Blister 5/10 pièces

"MASTERBIT TORSION"

PLANA / FLAT / PLATE / FLACH / PIATTA / SLEUF / PLANA

| COD | | | | PCS |
|-------|---------|----|--|-----|
| 66533 | 4x0,5 | 25 | | 5 |
| 66694 | | | | 10 |
| 66534 | 4,5x0,6 | | | 5 |
| 66695 | | | | 10 |
| 66535 | 5,5x0,8 | | | 5 |
| 66696 | | | | 10 |
| 66536 | 5,5x1 | | | 5 |
| 66697 | | | | 10 |
| 66537 | 6,5x1,2 | | | 5 |
| 66698 | | | | 10 |



PHILIPS

| COD | | | | PCS |
|-------|------|----|--|-----|
| 66522 | PH-1 | 25 | | 5 |
| 66699 | | | | 10 |
| 66523 | PH-2 | | | 5 |
| 66700 | | | | 10 |
| 66524 | PH-3 | | | 5 |
| 66701 | | | | 10 |



POZIDRIV

| COD | | | | PCS |
|-------|------|----|--|-----|
| 66543 | PZ-1 | 25 | | 5 |
| 66702 | | | | 10 |
| 66544 | PZ-2 | | | 5 |
| 66703 | | | | 10 |
| 66545 | PZ-3 | | | 5 |
| 66704 | | | | 10 |



"MASTERBIT NON-SLIP"

PHILIPS

| COD | | | | PCS |
|-------|------|----|--|-----|
| 66546 | PH-1 | 25 | | 5 |
| 66705 | | | | 10 |
| 66547 | PH-2 | | | 5 |
| 66706 | | | | 10 |
| 66548 | PH-3 | | | 5 |
| 66707 | | | | 10 |



POZIDRIV

| COD | | | | PCS |
|-------|------|----|--|-----|
| 66568 | PZ-1 | 25 | | 5 |
| 66708 | | | | 10 |
| 66569 | PZ-2 | | | 5 |
| 66709 | | | | 10 |
| 66570 | PZ-3 | | | 5 |
| 66710 | | | | 10 |







Empaquetado en blister en 5/10 uds. / 5/10 pcs. blister packaging / Conditionnement Blister 5/10 pièces

NATO Commercial and Government Entity (NCAGE) Code / Código (NCAGE) OTAN: 8552B







"MASTERBIT TIN"

PHILIPS

| COD |  |  |  | PCS |
|-------|---|---|---|-----|
| 66605 | PH-1 | 25 |  | 5 |
| 66711 | | | | 10 |
| 66606 | PH-2 | | | 5 |
| 66712 | | | | 10 |
| 66607 | PH-3 | | | 5 |
| 66713 | | | | 10 |







 1/4"

| COD |  |  |  | PCS |
|-------|---|---|---|-----|
| 66608 | PH-1 | 50 |  | 5 |
| 66714 | | | | 10 |
| 66609 | PH-2 | | | 5 |
| 66715 | | | | 10 |
| 66610 | PH-3 | | | 5 |
| 66716 | | | | 10 |







 1/4"

POZIDRIV

| COD |  |  |  | PCS |
|-------|--|--|--|-----|
| 66611 | PZ-1 | 25 |  | 5 |
| 66717 | | | | 10 |
| 66612 | PZ-2 | | | 5 |
| 66718 | | | | 10 |
| 66613 | PZ-3 | | | 5 |
| 66719 | | | | 10 |



 1/4"

| COD |  |  |  | PCS |
|-------|---|---|---|-----|
| 66614 | PZ-1 | 50 |  | 5 |
| 66720 | | | | 10 |
| 66615 | PZ-2 | | | 5 |
| 66721 | | | | 10 |
| 66616 | PZ-3 | | | 5 |
| 66722 | | | | 10 |



 1/4"

TORX

| COD |  |  |  | PCS |
|-------|---|---|---|-----|
| 66617 | T-10 | 25 |  | 5 |
| 66723 | | | | 10 |
| 66618 | T-15 | | | 5 |
| 66724 | | | | 10 |
| 66619 | T-20 | | | 5 |
| 66725 | | | | 10 |
| 66620 | T-25 | 5 | | |
| 66726 | | 10 | | |
| 66621 | T-30 | 5 | | |
| 66727 | | 10 | | |
| 66622 | T-40 | 5 | | |
| 66728 | | 10 | | |



 1/4"



ADAPTADORES PORTAPUNTAS MAGNETICOS / MAGNETIC BIT HOLDER / ADAPTATEUR PORTE-EMBOUTS
MAGNÉTIQUES / MAGNETISCHE SCHRAUBENDREHER BITHALTER / PORTA INSERTI MAGNETICO
MAGNETISCHE SCHROEVENDRAAIER BITHOUDER / ADAPTADOR PORTA PONTAS MAGNETICO

| | | | | | |
|--------------------|----|------|------|----|---|
| INDX COD | | | | | |
| 66261 | 60 | 1/4" | 1/4" | 20 | 1 |



TIPO "PULL" / "PULL" TYPE / TYPE " Á TIRER" / ZIEH-TYP / TIPO "PULL" / TREKTYPE / TIPO "PULL"

| | | | | | |
|--------------------|----|------|------|----|---|
| INDX COD | | | | | |
| 66262 | 60 | 1/4" | 1/4" | 30 | 1 |

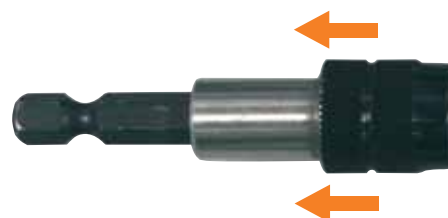

TIPO "PUSH" / "PUSH" TYPE / TYPE " Á POUSSER" / DRUCK-TYP / TIPO "PUSH" / DRUKTYPE / TIPO "PUSH"

| | | | | | |
|--------------------|----|------|------|----|---|
| INDX COD | | | | | |
| 66263 | 60 | 1/4" | 1/4" | 30 | 1 |

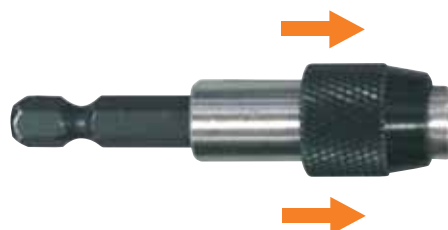



AUTOMATICO TIPO "PULL" / AUTOMATIC "PULL" TYPE / AUTOMATIQUE TYPE " Á TIRER" / AUTO ZIEH-TYP / TIPO "PULL" AUTOMATICO
AUTO TREKTYPE / AUTOMÁTICO TIPO "PULL"

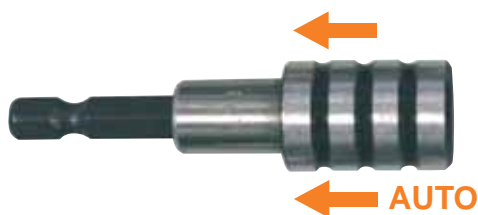

| | | | | | |
|--------------------|----|------|------|----|---|
| INDX COD | | | | | |
| 66264 | 75 | 1/4" | 1/4" | 35 | 1 |





SETS

| COD | PCS. | COMPOSICION / COMPOSITION |  |  |  |
|-------|------|---|---|---|--|
| 66941 | | PH1(6) - PH2(10) - PH3(4) - PZ1(4) - PZ2(6) - PZ3(2) | COD. 66261 | 250 | 1 |
| 66942 | 32 | PH1(2) - PH2(2) - PH3(1) - PZ1(2) - PZ2(2) - PZ3(1) - T10(1) T15(1) - T20(1) - T25(1) - T27(1) - T30(1) - T40(1) 4,5x0,6(2) - 5,5x0,8(2) - 6,5x1,2(2) - 8x1,6(2) HEX3(2) - HEX4(2) - HEX5(2) - HEX6(1) | | | |
| 66943 | | T5(2) - T6(3) - T7(3) - T8(3) - T9(3) - T10(3) - T15(3) - T20(3) - T25(3) - T27(2) - T30(2) - T40(2) | | | |





| COD | PCS. | COMPOSICION / COMPOSITION |  |  |  |
|-------|------|--|---|---|--|
| 66944 | | 3x0,5(1) - 4,5x0,6(1) - 5,5x0,8(1) - 5,5x1(1) - 6,5x1,2(1) 8x1,6(1) - HEX1,5(1) - HEX2(1) - HEX3(1) - HEX4(1) HEX5(1) - HEX6(1) - HEX7(1) - HEX8(1) - T6(1) - T7(1) T8(1) - T9(1) - T10(1) - T15(1) - T20(1) - T27(1) - T30(1) PH1(1) - PH2(1) - PH3(1) - PZ1(1) - PZ2(1) - PZ3(1) | COD. 66262 | 240 | 1 |
| 66945 | 30 | PH0(2) - PH1(4) - PH2(6) - PH3(4) - PH4(2) PZ0(1) - PZ1(3) - PZ2(4) - PZ3(3) - PZ4(1) | | | |
| 66946 | | T5(2) - T6(3) - T7(3) - T8(3) - T9(3) - T10(3) - T15(3) T20(2) - T25(2) - T27(2) - T30(2) - T40(2) | | | |
| 66947 | | PH1(3) - PH2(3) - PH3(3) - PZ1(3) - PZ2(3) - PZ3(3) T10(2) - T15(2) - T20(2) - T25(2) - T30(2) - T40(2) (TIN) | | | |



| COD | PCS. | COMPOSICION / COMPOSITION |  |  |  |
|-------|------|---|---|---|--|
| 66948 | | 5,5x1(1) - 6,5x1,2(1) - PH1(1) - PH2 - PH3(1) PZ1(1) - PZ2(1) - PZ3(1) | COD. 66261 | 120 | 1 |
| 66949 | | T7(1) - T8(1) - T9(1) - T10(1) - T15(1) T20(1) - T25(1) - T27(1) - T30(1) | | | |
| 66950 | 9 | PH1(1) - PH2(1) - PH3(1) - PZ1(1) - PZ2(1) PZ3(1) - T15(1) - T20(1) - T30(1) | | | |
| 66951 | | PH1(2) - PH2(2) - PH3(2) - PZ1(1) - PZ2(1) - PZ3(1) (TIN) | | | |
| 66952 | | PH1(2) - PH2(2) - PH3(2) - PZ1(1) - PZ2(1) - PZ3(1) (TORSION) | | | |



| COD | PCS. | COMPOSICION / COMPOSITION |  |  |  |
|-------|------|--|---|---|--|
| 66953 | | PH1(1) - PH2(1) - PH3(1) - PZ1(1) - PZ2(1) - PZ3(1) 4X0,8 (50mm)(1) - 5,5x1 (50mm)(1) | COD. 66261 | 140 | 1 |
| 66954 | | 3x0,5(1) - 4,5x0,6(1) - 5,5x0,8(1) - 5,5x1(1) - 6,5x1,2(1) 8x1,6(1) - 4X0,8 (50mm)(1) - 5,5x1 (50mm)(1) | | | |
| 66955 | 8 | T6(1) - T7(1) - T8(1) - T9(1) - T10(1) - T15(1) T20(50mm)(1) - T25 (50mm)(1) | | | |
| 66956 | | PH1(1) - PH2(1) - PH3(1) - PZ1(1) - PZ2(1) - PZ3(1) PH2 (50mm)(1) - PZ2 (50mm)(1) | | | |



PUNTAS ATORNILLADORAS CON VASO / SOCKET BITS / EMBOUTS DE VISSAGE AVEC DOUILLE
 SOCKETS BITS / INSERTI A BUSSOLA / DOPSLEUTELINZET / PONTAS APARAFUSADORAS COM CAIXA

1/4"

PLANA / FLAT / PLATE / FLACH / PIATTA / SLEUF / PLANA

| COD | | | | | | |
|-------|---------|----|----|----|---|--|
| 66733 | 0,8x4 | 37 | 15 | 10 | 1 | |
| 66734 | 1x5,5 | | | | | |
| 66735 | 1,2x6,5 | | | | | |
| 66736 | 1,2x8 | | | | | |



PHILIPS

| COD | | | | | |
|-------|------|----|----|----|---|
| 66737 | PH-1 | 37 | 15 | 10 | 1 |
| 66738 | PH-2 | | | | |
| 66739 | PH-3 | | | | |



POZIDRIV

| COD | | | | | |
|-------|------|----|----|----|---|
| 66740 | PZ-1 | 37 | 15 | 10 | 1 |
| 66741 | PZ-2 | | | | |
| 66742 | PZ-3 | | | | |



HEXAGONAL / HEXAGONAL / HEXAGONALE / HEXAGONAL / ESANGONALO / HEX / HEXAGONAL

| COD | | | | | |
|-------|---|----|----|----|---|
| 66743 | 3 | 37 | 15 | 10 | 1 |
| 66744 | 4 | | | | |
| 66745 | 5 | | | | |
| 66746 | 6 | | | | |
| 66747 | 8 | | | | |



TORX

| COD | | | | | |
|-------|------|----|----|----|---|
| 66748 | T-8 | 37 | 15 | 10 | 1 |
| 66749 | T-9 | | | | |
| 66750 | T-10 | | | | |
| 66751 | T-15 | | | | |
| 66752 | T-20 | | | | |
| 66753 | T-25 | | | | |
| 66754 | T-27 | | | | |
| 66755 | T-30 | | | | |
| 66756 | T-40 | | | | |





SETS

| COD | PCS. | COMPOSICION / COMPOSITION | | |
|-------|------|--|-----|---|
| 66757 | 12 | 0,8x4 - 1x5,5 - 1,2x6,5 - 1,2x8 - PH-1 - PH-2 - PH-3 HEX-3 - HEX-4 - HEX-5 - HEX-6 - HEX8 | 250 | 1 |
| 66758 | | 0,8x4 - 1x5,5 - 1,2x6,5 - 1,2x8 - PZ-1 - PZ-2 - PZ-3 HEX-3 - HEX-4 - HEX-5 - HEX-6 - HEX8 | | |
| 66759 | 9 | T-8 - T-9 - T-10 - T-15 - T-20 T-25 - T-27 - T-30 - T-40 | 205 | |







3/8"

PLANA / FLAT / PLATE / FLACH / PIATTA / SLEUF / PLANA

| COD |  |  |  |  |  |
|-------|---|---|---|---|---|
| 66760 | 1x5,5 | 48 | 35 | 10 | 1 |
| 66761 | 1,2x6,5 | | | | |
| 66762 | 1,2x8 | | | | |
| 66763 | 1,5x8 | | | | |
| 66764 | 1,6x10 | | | | |







PHILIPS

| COD |  |  |  |  |  |
|-------|---|---|---|---|---|
| 66765 | PH-1 | 48 | 35 | 10 | 1 |
| 66766 | PH-2 | | | | |
| 66767 | PH-3 | | | | |







POZIDRIV

| COD |  |  |  |  |  |
|-------|---|---|---|---|---|
| 66768 | PZ-1 | 48 | 35 | 10 | 1 |
| 66769 | PZ-2 | | | | |
| 66770 | PZ-3 | | | | |







HEXAGONAL / HEXAGONAL / HEXAGONALE / HEXAGONAL / ESANGONALO / HEX / HEXAGONAL

| COD |  |  |  |  |  |
|-------|---|---|---|---|---|
| 66771 | 3 | 48 | 35 | 10 | 1 |
| 66772 | 4 | | | | |
| 66773 | 5 | | | | |
| 66774 | 6 | | | | |
| 66775 | 7 | | | | |
| 66776 | 8 | | | | |
| 66777 | 10 | | | | |







HEXAGONAL SERIE LARGA / HEXAGONAL LONG / HEXAGONALE SERIE LONGUE / HEXAGONAL LANG
ESANGONALO SERIE LUNGO / HEX LANG / HEXAGONAL SÉRIE LONGA

| COD |  |  |  |  |  |
|-------|---|---|---|---|---|
| 66778 | 4 | 92 | 70 | 10 | 1 |
| 66779 | 5 | | | | |
| 66780 | 6 | | | | |
| 66781 | 8 | | | | |
| 66782 | 10 | | | | |



HEXAGONAL PUNTA DE BOLA SERIE LARGA / HEXAGONAL BALL POINT LONG SERIE / HEXAGONALE EMBOUT SPHERIQUE SERIE LONGUE / HEXAGONAL KUGELKOPF LANG / ESANGONALO TESTA SFERICA SERIE LUNGO / HEX KOGELKOP LANG
HEXAGONAL PONTA ESFERICA SÉRIE LONGA

| COD |  |  |  |  |  |
|-------|---|---|---|---|---|
| 66783 | 4 | 92 | 70 | 10 | 1 |
| 66784 | 5 | | | | |
| 66785 | 6 | | | | |
| 66786 | 8 | | | | |
| 66787 | 10 | | | | |



TORX

| COD | | | | | |
|-------|------|----|----|----|---|
| 66788 | T-10 | 48 | 35 | 10 | 1 |
| 66789 | T-15 | | | | |
| 66790 | T-20 | | | | |
| 66791 | T-25 | | | | |
| 66792 | T-27 | | | | |
| 66793 | T-30 | | | | |
| 66794 | T-40 | | | | |
| 66795 | T-45 | | | | |
| 66796 | T-50 | | | | |



SETS

| COD | PCS. | COMPOSICION | | |
|-------|------|--|-----|---|
| 66797 | 11 | 1x5,5 - 1,2x6,5 - 1,2x8 - 1,5x8 - 1,6x10 - PH-1 - PH-2 - PH-3 - PZ-1 - PZ-2 - PZ-3 | 450 | 1 |
| 66798 | 12 | HEX-3 - HEX-4 - HEX-5 - HEX-6 - HEX-7 - HEX-8 - HEX-10 - HEX-4(L) - HEX-5(L) - HEX-6(L) - HEX-8(L) - HEX-10(L) | 650 | |
| 66799 | | HEX-3 - HEX-4 - HEX-5 - HEX-6 - HEX-7 - HEX-8 - HEX-10 - HEX-4(L-B) - HEX-5(L-B) - HEX-6(L-B) - HEX-8(L-B) - HEX-10(L-B) | | |
| 66800 | 9 | T-10 - T-15 - T-20 - T-25 - T-27 - T-30 - T-40 - T-45 - T-50 | 350 | |



1/2"

PLANA / FLAT / PLATE / FLACH / PIATTA / SLEUF / PLANA

| COD | | | | | |
|-------|--------|----|----|----|---|
| 66801 | 1,2x8 | 62 | 75 | 10 | 1 |
| 66802 | 1,6x10 | | | | |
| 66803 | 2x12 | | | | |



PHILIPS

| COD | | | | | |
|-------|------|----|----|----|---|
| 66804 | PH-2 | 56 | 70 | 10 | 1 |
| 66805 | PH-3 | | | | |
| 66806 | PH-4 | | | | |







HEXAGONAL / HEXAGONAL / HEXAGONALE / HEXAGONAL / ESANGONALO / HEX / HEXAGONAL

| COD | | | | | |
|-------|----|----|----|----|---|
| 66807 | 4 | 53 | 75 | 10 | 1 |
| 66808 | 5 | | | | |
| 66809 | 6 | | | | |
| 66810 | 7 | | | | |
| 66811 | 8 | | | | |
| 66812 | 10 | | | | |
| 66813 | 12 | | | | |
| 66814 | 14 | | | | |







PUNTAS DE DESTORNILLADOR / BITS / POINTES DE TOURNEVIS / BITS INSERTI / BITSEN / PONTAS

HEXAGONAL SERIE LARGA / HEXAGONAL LONG / HEXAGONALE SERIE LONGUE / HEXAGONAL LANG / ESANGONALO SERIE LUNGO / HEX LANG / HEXAGONAL SÉRIE LONGA

| COD |  |  |  |  |  |
|-------|---|---|---|---|---|
| 66815 | 5 | 100 | 75 | 10 | 1 |
| 66816 | 6 | | | | |
| 66817 | 7 | | | | |
| 66818 | 8 | | | | |
| 66819 | 10 | | | | |







XZN

| COD |  |  |  |  |  |
|-------|---|---|---|---|---|
| 66820 | M-5 | 55 | 75 | 10 | 1 |
| 66821 | M-6 | | | | |
| 66822 | M-8 | | 85 | | |
| 66823 | M-10 | | | | |
| 66824 | M-12 | | | | |
| 66825 | M-14 | 105 | | | |







XZN SERIE LARGA / XZN LONG / XZN SERIE LONGUE / XZN LANG / XZN SERIE LUNGO / XZN LANG / XZN SÉRIE LONGA

| COD |  |  |  |  |  |
|-------|---|---|---|---|---|
| 66826 | M-6 | 100 | 100 | 10 | 1 |
| 66827 | M-8 | | 120 | | |
| 66828 | M-10 | | 160 | | |
| 66829 | M-12 | | | | |







TORX

| COD |  |  |  |  |  |
|-------|---|---|---|---|---|
| 66830 | T-20 | 55 | 80 | 10 | 1 |
| 66831 | T-25 | | | | |
| 66832 | T-27 | | | | |
| 66833 | T-30 | | | | |
| 66834 | T-40 | | | | |
| 66835 | T-45 | | | | |
| 66836 | T-50 | | | | |
| 66837 | T-55 | | | | |



TORX SERIE LARGA / TORX LONG / TORX SERIE LONGUE / TORX LANG / TORX SERIE LUNGO / TORX LANG / TORX SÉRIE LONGA

| COD |  |  |  |  |  |
|-------|---|---|---|---|---|
| 66838 | T-40 | 100 | 100 | 10 | 1 |
| 66839 | T-45 | | 110 | | |
| 66840 | T-50 | | | | |
| 66841 | T-55 | | | | |





*LIMAS, ESCOFINAS, BOTADORES Y GRANETES / FILES, RASPS & PUNCHES
LIMES, RAPES, POINTEAUX ET CHASSES GOUPILLES / FEILEN, RASPELN,
DURCHSCHLÄGER UND KÖRNER / LIMA, RASPE E PUNZONI / VIJLEN, RASPEN
EN DOORSLAGEN / LIMAS, GROSAS E PUNÇÕES*

La gama completa de limas y escofinas super-profesionales EGA Master ofrece soluciones a todas las necesidades de acabado.

EGA Master super-professional file and rasp range offers solutions to all finishing needs.

La gamme complète de limes et de râpes super professionnelles EGA Master donne une solution à tous les problèmes.

| | | Debaste Roughing Bâtarde | Limado medio Medium filing Demi-douce | Afilado o limado fino Sharpening or smooth filing Douce |
|---|-----------------------------------|--------------------------------|---|---|
| Picado sencillo Single cut Une taille | | | ● ● | ● ● |
| Picado doble Double cut Doble coupe | Basto Bastard Bâtard | ● ● | ● | |
| | Entrefino Medium Demi douce | | ● ● | ● |
| | Fino Smooth Douce | | ● ● | ● ● |
| Escofina Rasp Râpe | | ● ● | | |



1 Acero alto en cromo y carbono.
High chrome and carbon steel.
Acier en haute teneur en chrome et carbone.

2 Templados hasta los 65HRC.
Tempered up to 65HRC.
Trempe jusqu'à 65HRC.

3 Mango Bi-componente ergonómico y antideslizante BIMAT® de gran atractivo.

Highly attractive BIMAT® ergonomic and anti-slippery handle.

Manche bi-matière, ergonomique et anti-dérapant très attrayant.

4 Protección antioxidante.
Rust-proof treatment.
Protection anti-oxydation.

| | | Fundición Casting Fonte | Acero sin templar Non Templed alloy Acier | Acero de alta aleación High Alloy steel Alliage d'acier | Latón bronce Brass Bronze Laiton bronze | Aluminio Aluminium Aluminium | Madera, Plásticos... Wood, plastic... Bois, plastique... |
|---|-----------------------------------|-------------------------------|---|---|---|------------------------------------|--|
| Picado sencillo Single cut Une taille | | | ● ● | ● ● | | | |
| Picado doble Double cut Doble coupe | Basto Bastard Bâtard | ● ● | ● ● | ● | ● ● | ● ● | ● |
| | Entrefino Medium Demi douce | ● ● | ● ● | ● ● | ● ● | ● ● | |
| | Fino Smooth Douce | ● | ● ● | ● ● | ● | | |
| Escofina Rasp Râpe | | | | | | | ● ● |

● Aceptable / Acceptable / Acceptable

● ● Adecuado / Appropriate / Idéal

LIMAS PLANAS PARALELAS / HAND FILES / LIMES PLATES PARALLELES / FLACHSTUMPF / LIMA PIATTA PARALLELA / HANDVIJLEN
LIMAS PARALELAS

| COD | L | MM/cm | | | A | B | gr. | | | |
|-------|-----|-------|----|-------|----|-----|-----|----|----|---|
| 63473 | 4" | 1 | 14 | 81820 | 12 | 2,5 | 40 | 12 | | |
| 63474 | | 2 | 22 | | | | | | | |
| 63475 | | 3 | 28 | | | | | | | |
| 63476 | 6" | 1 | 11 | 81820 | 16 | 4 | 82 | | 12 | |
| 63477 | | 2 | 18 | | | | | | | |
| 63478 | | 3 | 22 | | | | | | | |
| 63479 | 8" | 1 | 10 | 81880 | 20 | 5 | 184 | | | 6 |
| 63480 | | 2 | 16 | | | | | | | |
| 63481 | | 3 | 20 | | | | | | | |
| 63482 | 10" | 1 | 9 | 81880 | 25 | 6 | 284 | 6 | | |
| 63483 | | 2 | 12 | | | | | | | |
| 63484 | | 3 | 18 | | | | | | | |
| 63485 | 12" | 1 | 8 | 81885 | 30 | 6,5 | 398 | | 6 | |
| 63486 | | 2 | 11 | | | | | | | |
| 63487 | | 3 | 16 | | | | | | | |
| 63488 | 14" | 1 | 7 | 81885 | 35 | 7,5 | 620 | | | 6 |
| 63489 | | 2 | 10 | | | | | | | |
| 63490 | | 3 | 14 | | | | | | | |

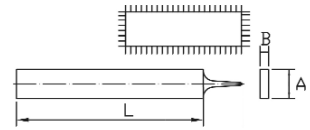

| COD | L | MM/cm | | | A | B | gr. | | | |
|-------|-----|-------|----|-----|----|-----|-----|----|----|---|
| 63491 | 4" | 1 | 14 | 85 | 12 | 2,5 | 45 | 12 | | |
| 63492 | | 2 | 22 | | | | | | | |
| 63493 | | 3 | 28 | | | | | | | |
| 63494 | 6" | 1 | 11 | 114 | 16 | 4 | 89 | | 12 | |
| 63495 | | 2 | 18 | | | | | | | |
| 63496 | | 3 | 22 | | | | | | | |
| 63497 | 8" | 1 | 10 | 114 | 20 | 5 | 200 | | | 6 |
| 63498 | | 2 | 16 | | | | | | | |
| 63499 | | 3 | 20 | | | | | | | |
| 63500 | 10" | 1 | 9 | 135 | 25 | 6 | 312 | 6 | | |
| 63501 | | 2 | 12 | | | | | | | |
| 63502 | | 3 | 18 | | | | | | | |
| 63503 | 12" | 1 | 8 | 135 | 30 | 6,5 | 415 | | 6 | |
| 63504 | | 2 | 11 | | | | | | | |
| 63505 | | 3 | 16 | | | | | | | |
| 63506 | 14" | 1 | 7 | 135 | 35 | 7,5 | 642 | | | 6 |
| 63507 | | 2 | 10 | | | | | | | |
| 63508 | | 3 | 14 | | | | | | | |



LIMAS PLANAS DE PUNTA / FLAT FILES / LIMES PLATES DE BOUT / FLACHSPITZ / LIMA PIATTA A PUNTA / VLAKKE VIJLEN
LIMAS CHATAS

| COD | L | MM/cm | | | A | B | gr. | | | |
|-------|-----|-------|----|-------|----|-----|-----|----|----|---|
| 63509 | 4" | 1 | 14 | 81820 | 12 | 2,5 | 36 | 12 | | |
| 63510 | | 2 | 22 | | | | | | | |
| 63511 | | 3 | 28 | | | | | | | |
| 63512 | 6" | 1 | 11 | 81820 | 16 | 4 | 72 | | 12 | |
| 63513 | | 2 | 18 | | | | | | | |
| 63514 | | 3 | 22 | | | | | | | |
| 63515 | 8" | 1 | 10 | 81880 | 20 | 5 | 164 | | | 6 |
| 63516 | | 2 | 16 | | | | | | | |
| 63517 | | 3 | 20 | | | | | | | |
| 63518 | 10" | 1 | 9 | 81880 | 25 | 6 | 254 | 6 | | |
| 63519 | | 2 | 12 | | | | | | | |
| 63520 | | 3 | 18 | | | | | | | |
| 63521 | 12" | 1 | 8 | 81885 | 30 | 6,5 | 358 | | 6 | |
| 63522 | | 2 | 11 | | | | | | | |
| 63523 | | 3 | 16 | | | | | | | |
| 63524 | 14" | 1 | 7 | 81885 | 35 | 7,5 | 560 | | | 6 |
| 63525 | | 2 | 10 | | | | | | | |
| 63526 | | 3 | 14 | | | | | | | |

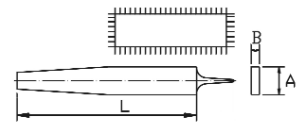

| COD | L | MM/cm | | | A | B | gr. | | | |
|-------|-----|-------|----|-----|----|-----|-----|----|----|---|
| 63527 | 4" | 1 | 14 | 85 | 12 | 2,5 | 40 | 12 | | |
| 63528 | | 2 | 22 | | | | | | | |
| 63529 | | 3 | 28 | | | | | | | |
| 63530 | 6" | 1 | 11 | 114 | 16 | 4 | 79 | | 12 | |
| 63531 | | 2 | 18 | | | | | | | |
| 63532 | | 3 | 22 | | | | | | | |
| 63533 | 8" | 1 | 10 | 114 | 20 | 5 | 180 | | | 6 |
| 63534 | | 2 | 16 | | | | | | | |
| 63535 | | 3 | 20 | | | | | | | |
| 63536 | 10" | 1 | 9 | 135 | 25 | 6 | 270 | 6 | | |
| 63537 | | 2 | 12 | | | | | | | |
| 63538 | | 3 | 18 | | | | | | | |
| 63539 | 12" | 1 | 8 | 135 | 30 | 6,5 | 375 | | 6 | |
| 63540 | | 2 | 11 | | | | | | | |
| 63541 | | 3 | 16 | | | | | | | |
| 63542 | 14" | 1 | 7 | 135 | 35 | 7,5 | 582 | | | 6 |
| 63543 | | 2 | 10 | | | | | | | |
| 63544 | | 3 | 14 | | | | | | | |



- 1 Basta / Bastard / Batarde / Bastard / Bastarda / Grof / Bastardo
- 2 Entrefina / Medium / Demi douce / Halbschlicht / Media / Meio murço
- 3 Fina / Smooth / Douce / Schlicht / Fine / Zacht / Murço

LIMAS, ESCOFINAS, BOTADORES Y GRANETES / FILES, RASPS & PUNCHES / LIMES, RAPES, POINTEAUX ET CHASSES GOUPILLES / FEILEN, RASPELN, DURCHSCHLÄGER UND KÖRNER LIMA, RASPE E PUNZONI / VIJLEN, RASPEN EN DOORSLAGEN / LIMAS, GROSAS E PUNÇÕES

LIMAS MEDIA CAÑA / HALF ROUND FILES / LIMES DEMI-RONDES / HALBRUND-FEILEN, SPITZE FORM / LIMA MEZZATONDA / HALFRONDE VIJLEN / LIMAS MEIA CANA

| COD | L | MM/cm | | A | B | gr | |
|-------|-----|-------|----|-------|------|-----|-----|
| 63545 | 4" | 1 | 14 | 81820 | 10,5 | 3 | 19 |
| 63546 | | 2 | 22 | | | | |
| 63547 | | 3 | 28 | | | | |
| 63548 | 6" | 1 | 11 | 81820 | 16 | 4,5 | 66 |
| 63549 | | 2 | 18 | | | | |
| 63550 | | 3 | 22 | | | | |
| 63551 | 8" | 1 | 10 | 81880 | 20 | 6 | 138 |
| 63552 | | 2 | 16 | | | | |
| 63553 | | 3 | 20 | | | | |
| 63554 | 10" | 1 | 9 | 81881 | 25 | 7 | 242 |
| 63555 | | 2 | 12 | | | | |
| 63556 | | 3 | 18 | | | | |
| 63557 | 12" | 1 | 8 | 81885 | 30 | 8,5 | 348 |
| 63558 | | 2 | 11 | | | | |
| 63559 | | 3 | 16 | | | | |
| 63560 | 14" | 1 | 7 | 81885 | 35 | 10 | 630 |
| 63561 | | 2 | 10 | | | | |
| 63562 | | 3 | 14 | | | | |

| COD | L | MM/cm | | A | B | gr | |
|-------|-----|-------|----|-----|------|-----|-----|
| 63563 | 4" | 1 | 14 | 85 | 10,5 | 3 | 24 |
| 63564 | | 2 | 22 | | | | |
| 63565 | | 3 | 28 | | | | |
| 63566 | 6" | 1 | 11 | 114 | 16 | 4,5 | 72 |
| 63567 | | 2 | 18 | | | | |
| 63568 | | 3 | 22 | | | | |
| 63569 | 8" | 1 | 10 | 114 | 20 | 6 | 150 |
| 63570 | | 2 | 16 | | | | |
| 63571 | | 3 | 20 | | | | |
| 63572 | 10" | 1 | 9 | 135 | 25 | 7 | 265 |
| 63573 | | 2 | 12 | | | | |
| 63574 | | 3 | 18 | | | | |
| 63575 | 12" | 1 | 8 | 135 | 30 | 8,5 | 370 |
| 63576 | | 2 | 11 | | | | |
| 63577 | | 3 | 16 | | | | |
| 63578 | 14" | 1 | 7 | 135 | 35 | 10 | 654 |
| 63579 | | 2 | 10 | | | | |
| 63580 | | 3 | 14 | | | | |

LIMAS TRIANGULARES / TRIANGULAR FILES / LIMES TRIANGULAIRES / DREIKANTFEILEN / LIMA TRIANGOLARE / DRIEHOEK VIJLEN / LIMATÕES TRIANGULARES

| COD | L | MM/cm | | A | gr | |
|-------|-----|-------|----|-------|------|-----|
| 63581 | 4" | 1 | 14 | 81820 | 8 | 22 |
| 63582 | | 2 | 22 | | | |
| 63583 | | 3 | 28 | | | |
| 63584 | 6" | 1 | 11 | 81820 | 11 | 64 |
| 63585 | | 2 | 18 | | | |
| 63586 | | 3 | 22 | | | |
| 63587 | 8" | 1 | 10 | 81880 | 15 | 140 |
| 63588 | | 2 | 16 | | | |
| 63589 | | 3 | 20 | | | |
| 63590 | 10" | 1 | 9 | 81881 | 17,5 | 202 |
| 63591 | | 2 | 12 | | | |
| 63592 | | 3 | 18 | | | |
| 63593 | 12" | 1 | 8 | 81885 | 20 | 324 |
| 63594 | | 2 | 11 | | | |
| 63595 | | 3 | 16 | | | |
| 63596 | 14" | 1 | 7 | 81885 | 24 | 605 |
| 63597 | | 2 | 10 | | | |
| 63598 | | 3 | 14 | | | |

| COD | L | MM/cm | | A | gr | |
|-------|-----|-------|----|-----|------|-----|
| 63599 | 4" | 1 | 14 | 85 | 8 | 27 |
| 63600 | | 2 | 22 | | | |
| 63601 | | 3 | 28 | | | |
| 63602 | 6" | 1 | 11 | 114 | 11 | 71 |
| 63603 | | 2 | 18 | | | |
| 63604 | | 3 | 22 | | | |
| 63605 | 8" | 1 | 10 | 114 | 15 | 152 |
| 63606 | | 2 | 16 | | | |
| 63607 | | 3 | 20 | | | |
| 63608 | 10" | 1 | 9 | 135 | 17,5 | 204 |
| 63609 | | 2 | 12 | | | |
| 63610 | | 3 | 18 | | | |
| 63611 | 12" | 1 | 8 | 135 | 20 | 344 |
| 63612 | | 2 | 11 | | | |
| 63613 | | 3 | 16 | | | |
| 63614 | 14" | 1 | 7 | 135 | 24 | 625 |
| 63615 | | 2 | 10 | | | |
| 63616 | | 3 | 14 | | | |

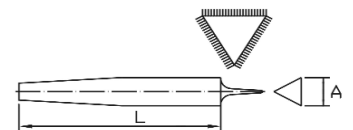
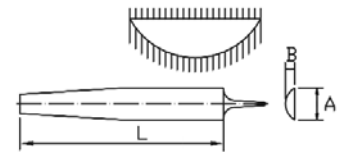

- 1 Basta / Bastard / Batarde / Bastard / Bastarda / Grof / Bastardo
- 2 Entrefina / Medium / Demi douce / Halbschlicht / Media / Meio murço
- 3 Fina / Smooth / Douce / Schlicht / Fine / Zacht / Murço

LIMAS CUADRADAS / SQUARE FILES / LIMES CARREES / VIERKANTFEILEN / LIMA QUADRA / VIERKANT VIJLEN
LIMATÕES QUADRADOS

| COD | L | MM/cm | | A | gr | |
|-------|-----|-------|----|-------|----|-----|
| 63617 | 4" | 1 | 14 | 81819 | 4 | 14 |
| 63618 | | 2 | 22 | | | |
| 63619 | | 3 | 28 | | | |
| 63620 | 6" | 1 | 11 | 81819 | 6 | 32 |
| 63621 | | 2 | 18 | | | |
| 63622 | | 3 | 22 | | | |
| 63623 | 8" | 1 | 10 | 81878 | 8 | 86 |
| 63624 | | 2 | 16 | | | |
| 63625 | | 3 | 20 | | | |
| 63626 | 10" | 1 | 9 | 81878 | 10 | 120 |
| 63627 | | 2 | 12 | | | |
| 63628 | | 3 | 18 | | | |
| 63629 | 12" | 1 | 8 | 81938 | 12 | 272 |
| 63630 | | 2 | 11 | | | |
| 63631 | | 3 | 16 | | | |
| 63632 | 14" | 1 | 7 | 81938 | 15 | 545 |
| 63633 | | 2 | 10 | | | |
| 63634 | | 3 | 14 | | | |

| COD | L | MM/cm | | A | gr | |
|-------|-----|-------|----|-----|----|-----|
| 63635 | 4" | 1 | 14 | 85 | 4 | 18 |
| 63636 | | 2 | 22 | | | |
| 63637 | | 3 | 28 | | | |
| 63638 | 6" | 1 | 11 | 114 | 6 | 36 |
| 63639 | | 2 | 18 | | | |
| 63640 | | 3 | 22 | | | |
| 63641 | 8" | 1 | 10 | 135 | 8 | 96 |
| 63642 | | 2 | 16 | | | |
| 63643 | | 3 | 20 | | | |
| 63644 | 10" | 1 | 9 | 135 | 10 | 130 |
| 63645 | | 2 | 12 | | | |
| 63646 | | 3 | 18 | | | |
| 63647 | 12" | 1 | 8 | 135 | 12 | 392 |
| 63648 | | 2 | 11 | | | |
| 63649 | | 3 | 16 | | | |
| 63650 | 14" | 1 | 7 | 135 | 15 | 565 |
| 63651 | | 2 | 10 | | | |
| 63652 | | 3 | 14 | | | |

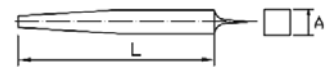

LIMAS REDONDAS / ROUND FILES / LIMES RONDES / RUNDFEILEN / LIMA TONDA / RONDVIJLEN / LIMATÕES REDONDOS

| COD | L | MM/cm | | A | gr | |
|-------|-----|-------|----|-------|-----|-----|
| 63653 | 4" | 1 | 13 | 81819 | 4 | 9 |
| 63654 | | 2 | 16 | | | |
| 63655 | | 3 | 19 | | | |
| 63656 | 6" | 1 | 11 | 81819 | 6 | 30 |
| 63657 | | 2 | 14 | | | |
| 63658 | | 3 | 17 | | | |
| 63659 | 8" | 1 | 10 | 81879 | 7,5 | 68 |
| 63660 | | 2 | 13 | | | |
| 63661 | | 3 | 16 | | | |
| 63662 | 10" | 1 | 9 | 81879 | 9,5 | 142 |
| 63663 | | 2 | 12 | | | |
| 63664 | | 3 | 15 | | | |
| 63665 | 12" | 1 | 8 | 81938 | 12 | 245 |
| 63666 | | 2 | 11 | | | |
| 63667 | | 3 | 14 | | | |
| 63668 | 14" | 1 | 7 | 81938 | 15 | 515 |
| 63669 | | 2 | 10 | | | |
| 63670 | | 3 | 13 | | | |

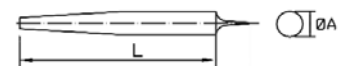

| COD | L | MM/cm | | A | gr | |
|-------|-----|-------|----|-----|-----|-----|
| 63671 | 4" | 1 | 13 | 85 | 4 | 13 |
| 63672 | | 2 | 16 | | | |
| 63673 | | 3 | 19 | | | |
| 63674 | 6" | 1 | 11 | 114 | 6 | 34 |
| 63675 | | 2 | 14 | | | |
| 63676 | | 3 | 17 | | | |
| 63677 | 8" | 1 | 10 | 135 | 7,5 | 76 |
| 63678 | | 2 | 13 | | | |
| 63679 | | 3 | 16 | | | |
| 63680 | 10" | 1 | 9 | 135 | 9,5 | 152 |
| 63681 | | 2 | 12 | | | |
| 63682 | | 3 | 15 | | | |
| 63683 | 12" | 1 | 8 | 135 | 12 | 268 |
| 63684 | | 2 | 11 | | | |
| 63685 | | 3 | 14 | | | |
| 63686 | 14" | 1 | 7 | 135 | 15 | 535 |
| 63687 | | 2 | 10 | | | |
| 63688 | | 3 | 13 | | | |

- 1 Basta / Bastard / Batarde / Bastard / Bastarda / Grof / Bastardo
- 2 Entrefina / Medium / Demi douce / Halbschlicht / Media / Meio murço
- 3 Fina / Smooth / Douce / Schlicht / Fine / Zacht / Murço

JUEGOS / SETS

JUEGO DE 5 LIMAS DE 10" BASTA / 10" BASTARD FILE SET 5 PCS / JEU DE 5 LIMES BATARDES 10" / SET BASTARD PFEILEN 5 STUCK / KIT 5 LIME BASTARDE 10" / SET BASTAARD VIJLEN 5 STUKS / JOGO DE 5 LIMAS DE 10" BASTARDAS

| COD | ← L → | Composición / Composition | |
|-------|-------|---------------------------|--|
| 63760 | 10" | 63536 | Lima plana punta basta Bastard flat file |
| | | 63572 | Lima media caña basta Bastard half round file |
| | | 63608 | Lima triangular basta Bastard triangular file |
| | | 63644 | Lima cuadrada basta Bastard square file |
| | | 63680 | Lima redonda basta Bastard round file |

JUEGO DE 5 LIMAS DE 10" ENTREFINA / 10" MEDIUM FILE SET 5 PCS / JEU DE 5 LIMES DEMI-DOUCES 10" / SET MEDIUM PFEILEN 5 STUCK / KIT 5 LIME EXTRA FINE 10" / SET MEDIUM VIJLEN 5 STUKS / JOGO DE 5 LIMAS 10" MEIO MURÇO

| COD | ← L → | Composición / Composition | |
|-------|-------|---------------------------|---|
| 63762 | 10" | 63537 | Lima plana punta entrefina Medium flat file |
| | | 63573 | Lima media caña entrefina Medium half round file |
| | | 63609 | Lima triangular entrefina Medium triangular file |
| | | 63645 | Lima cuadrada entrefina Medium square file |
| | | 63681 | Lima redonda entrefina Medium round file |

NEW



JUEGO DE 5 LIMAS DE 10" FINA / 10" SMOOTH FILE SET 5 PCS / JEU DE 5 LIMES DOUCES 10" / SET SCHLICHT PFEILEN 5 STUCK / KIT 5 LIME FINE 10" / SET ZOETE VIJLEN 5 STUKS / JOGO DE 5 LIMAS 10" MURÇO

| COD | ← L → | Composición / Composition | |
|-------|-------|---------------------------|--|
| 63767 | 10" | 63538 | Lima plana punta fina Smooth flat file |
| | | 63574 | Lima media caña fina Smooth half round file |
| | | 63610 | Lima triangular fina Smooth triangular file |
| | | 63646 | Lima cuadrada fina Smooth square file |
| | | 63682 | Lima redonda fina Smooth round file |

LIMA PLANA / FARMER'S OWN / LIME PLATE / HABILISFEILEN / LIMA PIATTA / VLAKKE VIJLEN / LIMA PLANA

| COD | L | W | W/cm | A | B | gr. | |
|-------|----|---|------|----|---|-----|----|
| 63689 | 8" | 2 | 16 | 25 | 5 | 230 | 12 |

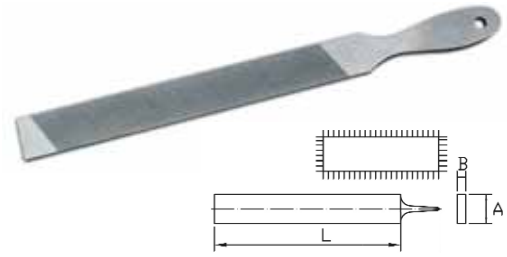

LIMAS AFILADO / SHARPENING FILES / LIMES AIGUILLES / SCHÄRFFEILEN LIMA AFFILATA / SCHERPVIJLEN / LIMAS DE AFIAR, DE AGRICULTOR

LIMA TRIANGULAR DELGADA / SLIM TAPER SAW / LIME TRIANGULAIRE ETROITE
PRÄZISIONNADELFEILEN DÜNN / LIMA TRIANGOLARE SOTTILE PRECISIE-VIJL SMAL
LIMAS TRIANGULARES FINAS

| COD | L | W | A | B | gr. | |
|-------|----|---|-------|-----|-----|----|
| 63690 | 4" | 4 | 81819 | 4,5 | 7,5 | 12 |
| 63691 | 5" | | | 6 | 17 | |

| COD | L | W | A | B | gr. | |
|-------|----|---|----|-----|-----|----|
| 63692 | 4" | 4 | 85 | 4,5 | 10 | 12 |
| 63693 | 5" | | | 6 | 25 | |

LIMA TRIANGULAR EXTRA-DELGADA / EXTRA REGULAR TAPER SAW / LIME EXTRA FINE
DREIKANTFEILEN / LIMA TRIANGOLARE EXTRA-SOTTILE / PRECISIE-VIJL NORMAAL
LIMAS TRIANGULARES EXTRA-FINAS

| COD | L | W | A | B | gr. | |
|-------|----|---|-------|---|-----|----|
| 63694 | 4" | 4 | 81819 | 4 | 7 | 12 |
| 63695 | 5" | | | 5 | 12 | |

| COD | L | W | A | B | gr. | |
|-------|----|---|----|---|-----|----|
| 63696 | 4" | 4 | 85 | 4 | 10 | 12 |
| 63697 | 5" | | | 5 | 20 | |

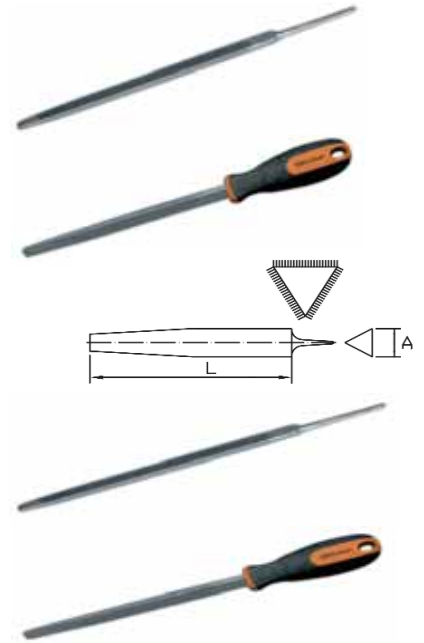

ESCOFINAS / RASPS / RAPES / SCHABER / RASPA / RASP / GROSAS

ESCOFINAS PLANAS PARALELAS / HAND WOOD RASPS / RAPES PLATES PARALLELES / HOLZSCHABER
RASPA PIATTA PARALLELA / HOUTRASP / GROSAS PARALELAS

| COD | L | W | Z | W/cm | A | B | gr. | | |
|-------|-----|----|---|-------|------|-----|-----|---|---|
| 63698 | 10" | 10 | 3 | 81881 | 23,7 | 6,7 | 125 | 6 | 1 |
| 63699 | 12" | | | | 27,7 | 7,7 | 225 | | |

| COD | L | W | Z | W/cm | A | B | gr. | | |
|-------|-----|----|---|------|------|------|-----|---|---|
| 63700 | 10" | 10 | 3 | 114 | 23,7 | 6,7 | 125 | 6 | 1 |
| 63701 | 12" | | | | 135 | 27,7 | 7,7 | | |

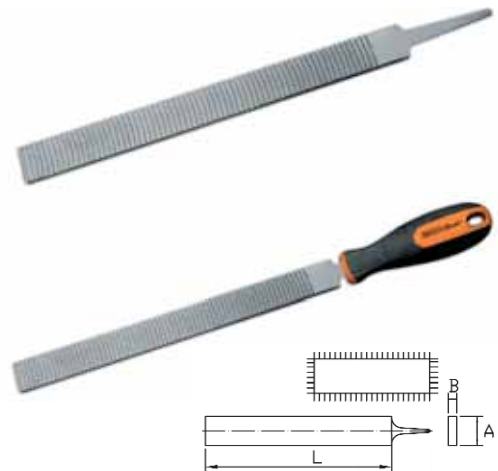

- 1 Basta / Bastard / Batarde / Bastard / Bastarda / Grof / Bastardo
- 2 Entrefina / Medium / Demi douce / Halbschlicht / Media / Meio murço
- 3 Fina / Smooth / Douce / Schlicht / Fine / Zacht / Murço
- 4 Extrafina / Very smooth / Extrafine / Doppelschlicht / Zeer zacht / Muito murço

LIMAS, ESCOFINAS, BOTADORES Y GRANETES / FILES, RASPS & PUNCHES / LIMES, RAPES, POINTEAUX ET CHASSES GOUPILLES / FEILEN, RASPELN, DURCHSCHLÄGER UND KÖRNER LIMA, RASPE E PUNZONI / VIJLEN, RASPEN EN DOORSLAGEN / LIMAS, GROSAS E PUNÇÕES

ESCOFINAS MEDIA CAÑA / HALF ROUND RASPS / RAPES DEMI-ROND / HALBRUND SCHABER / RASPA MEZZOTANDA / HALFRONDE RASP / GROSAS MEIA CANA

| COD | L | z | cm | A | B | gr | mm | mm | |
|-------|-----|----|----|-------|------|-----|-------|----|---|
| 63702 | 6" | 10 | 3 | 81820 | 16 | 4 | 80 | 6 | 1 |
| 63703 | 8" | | | 81880 | 19,7 | 5,2 | 137,5 | | |
| 63704 | 10" | | | 81881 | 23,7 | 6,7 | 237,5 | | |
| 63705 | 12" | | | 81885 | 27,7 | 7,7 | 375 | | |

| COD | L | z | cm | A | B | gr | mm | mm | |
|-------|-----|----|----|-----|------|-----|-------|----|---|
| 63706 | 6" | 10 | 3 | 85 | 16 | 4 | 80 | 6 | 1 |
| 63707 | 8" | | | 114 | 19,7 | 5,2 | 137,5 | | |
| 63708 | 10" | | | 114 | 23,7 | 6,7 | 237,5 | | |
| 63709 | 12" | | | 135 | 27,7 | 7,7 | 375 | | |



ESCOFINAS REDONDAS / ROUND RASPS / RAPES RONDES / RUNDSCHABER / RASPA TONDA / RONDE RASP / GROSAS REDONDAS

| COD | L | z | cm | A | B | gr | mm | mm |
|-------|-----|----|----|-------|------|-----|----|----|
| 63710 | 8" | 10 | 3 | 81879 | 9,5 | 61 | 6 | 1 |
| 63711 | 10" | | | 81879 | 11,5 | 124 | | |

| COD | L | z | cm | A | B | gr | mm | mm |
|-------|-----|----|----|-----|------|-----|----|----|
| 63712 | 8" | 10 | 3 | 114 | 9,5 | 61 | 6 | 1 |
| 63713 | 10" | | | 114 | 11,5 | 124 | | |



LIMAS DE AGUJA / NEEDLE FILES / LIMES AIGUILLES / NADELFEILEN / LIMA A PUNTA NAALDVIJL / LIMAS DE CALADO

LIMAS PLANAS PARALELAS / HAND FILES / LIMES PLATES PARALLELES / FLACHSTUMPF / LIMA PIATTA PARALLELA / HANDVIJLEN LIMAS PARALELAS

| COD | L | z | cm | A | B | gr | mm | mm |
|-------|----|---|----|------|-----|----|----|----|
| 63714 | 6" | 2 | 13 | 15,7 | 3,3 | 70 | 12 | 1 |

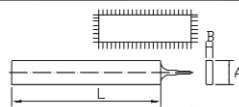

LIMAS PLANAS DE PUNTA / FLAT FILES / LIMES PLATES DE BOUT / FLACHSTUMPF / LIMA PIATTA A PUNTA / VLAKKE VIJLEN LIMAS CHATAS

| COD | L | z | cm | A | B | gr | mm | mm |
|-------|----|---|----|------|-----|------|----|----|
| 63715 | 6" | 2 | 13 | 15,7 | 3,3 | 67,5 | 12 | 1 |

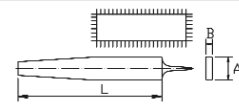

LIMAS MEDIA CAÑA / HALF ROUND FILES / LIMES DEMI-RONDES / HALBRUND-FEILEN / LIMA MEZZATONDA / HALFRONDE VIJLEN LIMAS MEIA CANA

| COD | L | z | cm | A | B | gr | mm | mm |
|-------|----|---|----|------|-----|----|----|----|
| 63716 | 6" | 2 | 16 | 15,7 | 4,2 | 66 | 12 | 1 |

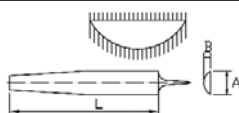

LIMAS REDONDAS / ROUND FILES / LIMES RONDES / RUNDFEILEN / LIMA TONDA / RONDVIJLEN / LIMATÕES REDONDOS

| COD | L | MM/cm | A | gr | | |
|-------|----|-------|----|-----|----|----|
| 63717 | 6" | 2 | 14 | 5,5 | 30 | 12 |

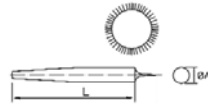

LIMAS TRIANGULARES / TRIANGULAR FILES / LIMES TRIANGULAIRES / DREIKANTFEILEN / LIMA TRIANGOLARE / DRIEHOEK VIJLEN
LIMAS TRIANGULARES

| COD | L | MM/cm | A | gr | | |
|-------|----|-------|----|------|----|----|
| 63718 | 6" | 2 | 20 | 10,8 | 59 | 12 |

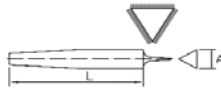

LIMAS CUADRADAS / SQUARE FILES / LIMES CARREES / VIERKANTFEILEN / LIMA QUADRA / VIERKANT VIJLEN
LIMATÕES QUADRADOS

| COD | L | MM/cm | A | gr | | |
|-------|----|-------|----|-----|----|----|
| 63719 | 6" | 2 | 16 | 5,2 | 34 | 12 |

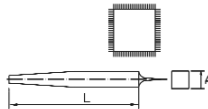

- 1 Basta / Bastard / Batarde / Bastard / Bastarda / Grof / Bastardo
- 2 Entrefina / Medium / Demi douce / Halbschlicht / Media / Meio murço
- 3 Fina / Smooth / Douce / Schlicht / Fine / Zacht / Murço

BOTADORES CILÍNDRICOS / PIN PUNCHES / CHASSES GOUPILLES / DURCHSCHLÄGER PUNZONE CILINDRICO / PENDRIJVERS / PUNÇÕES CILÍNDRICOS

CILINDRICOS Y MOLETEADOS / CYLINDRICAL AND KNURLED / CYLINDRIQUE ET MOLETE / ZYLINDERFÖRMIG UND GERÄNDLT
CILINDRICO E ZIGRINATO / CYLINDRISCH EN GEKARTELD / CILINDRICOS E RECARILHADOS

| COD | D | L | A | gr | |
|-------|------|-----|----|-----|----|
| 63380 | 2mm | 125 | 8 | 40 | 10 |
| 63381 | 3mm | | | 41 | |
| 63382 | 4mm | | | 43 | |
| 63383 | 5mm | | 10 | 63 | |
| 63384 | 6mm | | | 65 | |
| 63385 | 8mm | | | 91 | |
| 63386 | 10mm | | | 123 | |

Cr-V DIN 6450

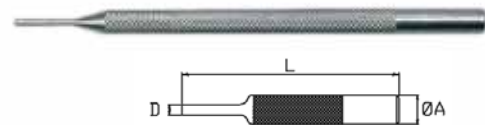

CILINDRICOS Y MOLETEADOS LARGOS / LONG CILINDRICAL AND KNURLED / CYLINDRIQUE LONGUE ET MOLETE
LANG ZYLINDERFÖRMIG UND GERÄNDLT / CILINDRICO E ZINGRINATO LARGO / LANG CYLINDRISCH EN GEKARTELD
CILINDRICOS E RECARILHADOS LONGOS



| COD | D | L | A | gr | |
|-------|------|-----|----|-----|----|
| 63387 | 2mm | 150 | 8 | 49 | 10 |
| 63388 | 3mm | | | 50 | |
| 63389 | 4mm | | | 54 | |
| 63390 | 5mm | | 10 | 77 | |
| 63391 | 6mm | | | 79 | |
| 63392 | 8mm | | | 116 | |
| 63393 | 10mm | | | 158 | |

Cr-V DIN 6450



LIMAS, ESCOFINAS, BOTADORES Y GRANETES / FILES, RASPS & PUNCHES / LIMES, RAPES, POINTEAUX ET CHASSES GOUPILLES / FEILEN, RASPELN, DURCHSCHLÄGER UND KÖRNER LIMA, RASPE E PUNZONI / VIJLEN, RASPEN EN DOORSLAGEN / LIMAS, GROSAS E PUNÇÕES

HEXAGONALES / HEXAGONAL / A SIX PANS / SECHSKANT / ESAGONALI / ZESKANT / HEXAGONAIS

| COD | D | L | A |  |  |
|-------|------|-----|----|---|---|
| 63394 | 2mm | 100 | 8 | 28 | 10 |
| 63395 | 3mm | | | 40 | |
| 63396 | 4mm | 150 | 10 | 42 | |
| 63397 | 5mm | | | 64 | |
| 63398 | 6mm | | | 67 | |
| 63399 | 8mm | | | 92 | |
| 63400 | 10mm | 12 | 94 | | |

DIN 6450

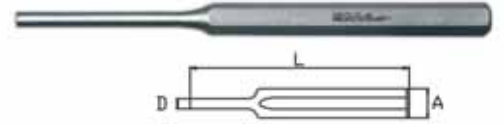



SET

| COD | D | |
|-------|-------|------|
| 63763 | 63394 | 2mm |
| | 63395 | 3mm |
| | 63396 | 4mm |
| | 63397 | 5mm |
| | 63398 | 6mm |
| | 63399 | 8mm |
| | 63400 | 10mm |



NEW



OCTOGONAL / OCTOGONAL / OKTOGONAL / OCTOGONAL / OTTAGONALE / OCTOGONAAL / OCTOGONAIS

| COD | D | L | A |  |  |
|-------|------|-----|----|---|---|
| 63401 | 2mm | 150 | 10 | 63 | 10 |
| 63402 | 3mm | | | 64 | |
| 63403 | 4mm | | | 65 | |
| 63404 | 5mm | | | 67 | |
| 63405 | 6mm | 12 | 12 | 71 | |
| 63406 | 8mm | | | 106 | |
| 63407 | 10mm | | | 120 | |

Cr-V DIN 6450



CON MANGO / WITH HANDLE / AVEC MANCHE / MIT GRIFF / CON MANICO / MET HANDGREEP / COM CABO



| COD | D | L | A |  |  |
|-------|------|-----|-----|---|---|
| 63447 | 2mm | 165 | 8 | 64 | 10 |
| 63448 | 3mm | 175 | 8 | 66 | |
| 63449 | 4mm | 185 | 10 | 100 | |
| 63450 | 5mm | 200 | | 108 | |
| 63451 | 6mm | | 210 | 12 | |
| 63452 | 7mm | 158 | | | |
| 63453 | 8mm | 170 | | | |
| 63454 | 9mm | 220 | 14 | 228 | |
| 63455 | 10mm | | | 238 | |
| 63456 | 12mm | 230 | 16 | 328 | |
| 63457 | 14mm | 240 | 18 | 428 | |
| 63458 | 16mm | 250 | | 492 | |

Cr-V DIN 6450



BOTADORES CONICOS / TAPER PUNCHES / CHASSE GOUPILLE / KÖRNER / PUNZONE CONICO CENTERPONS / PUNÇÕES CÔNICOS



CONICOS Y MOLETEADOS / CONICAL AND KNURLED / CONIQUE ET MOLETE / KONISCH UND GERÄNDALT / CONICO E ZIGRINATO CONISCH EN GEKARTELD / CONICOS E RECARILHADOS

| COD | D | L | A |  |  |
|-------|------|-----|-----|---|---|
| 63408 | 2mm | 125 | 8 | 44 | 10 |
| 63409 | 3mm | | | 45 | |
| 63410 | 4mm | | | 47 | |
| 63411 | 5mm | 10 | 12 | 68 | |
| 63412 | 6mm | | | 69 | |
| 63413 | 8mm | | | 99 | |
| 63414 | 10mm | 14 | 130 | | |

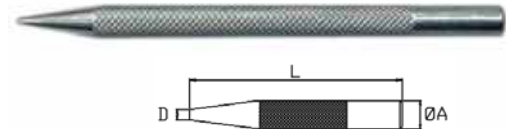
Cr-V DIN 6458



HEXAGONALES / HEXAGONAL / A SIX PANS / SECHSKANT / ESAGONALI / ZESKANT / HEXAGONAIS

| COD | D | L | A |  |  |
|-------|------|-----|----|---|---|
| 63415 | 2mm | 125 | 10 | 62 | 10 |
| 63416 | 3mm | | | 63 | |
| 63417 | 4mm | | | 64 | |
| 63418 | 5mm | 150 | 12 | 66 | |
| 63419 | 6mm | | | 69 | |
| 63420 | 8mm | | | 110 | |
| 63421 | 10mm | 122 | | | |

DIN 6458

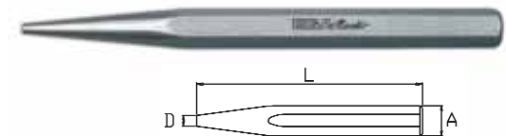



SET

| COD | D | |
|-------|-------|------|
| 63764 | 63415 | 2mm |
| | 63416 | 3mm |
| | 63417 | 4mm |
| | 63418 | 5mm |
| | 63419 | 6mm |
| | 63420 | 8mm |
| | 63421 | 10mm |



NEW



OCTOGONAL / OCTOGONAL / OCTOGONAL / OKTOGONAL / OTTAGONALE / OCTOGONAAL / OCTOGONAIS

| COD | D | L | A |  |  |
|-------|------|-----|----|---|---|
| 63422 | 2mm | 120 | 10 | 62 | 10 |
| 63423 | 3mm | | | 63 | |
| 63424 | 4mm | | | 77 | |
| 63425 | 5mm | 150 | 12 | 78 | |
| 63426 | 6mm | | | 80 | |
| 63427 | 8mm | | | 118 | |
| 63428 | 10mm | 133 | | | |

Cr-V DIN 6458



CON MANGO / WITH HANDLE / AVEC MANCHE / MIT GRIFF / CON MANICO / MET HANDGREEP / COM CABO

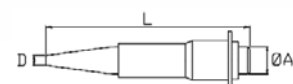

| COD | D | L | A |  |  |
|-------|------|-----|-----|---|---|
| 63459 | 2mm | 165 | 8 | 74 | 10 |
| 63460 | 3mm | 175 | | 78 | |
| 63461 | 4mm | 185 | | 112 | |
| 63462 | 5mm | | 10 | 116 | |
| 63463 | 6mm | | 118 | | |
| 63464 | 8mm | 12 | 12 | 168 | |
| 63465 | 10mm | | | 198 | |

Cr-V DIN 6458



GRANETES / CENTER PUNCHES / POINTEAUX / KÖRNER / PUNZONI DOORSLAGEN / PUNÇÕES



CILINDRICOS Y MOLETEADOS / CYLINDRICAL AND KNURLED / CYLINDRIQUE ET MOLETE / ZYLINDERFÖRMIG UND GERÄNDLT CILINDRICO E ZIGRINATO / CYLINDRISCH EN GEKARTELD / BICO CILINDRICOS E RECARILHADOS

| COD | D | L | A |  |  |
|-------|-------|-----|----|---|---|
| 63429 | 2,5mm | 125 | 8 | 42 | 10 |
| 63430 | 3mm | | | 43 | |
| 63431 | 4mm | | | 45 | |
| 63432 | 6mm | | 10 | 68 | |
| 63433 | 8mm | | 12 | 98 | |
| 63434 | 10mm | | 14 | 129 | |

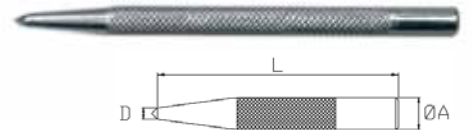
Cr-V DIN 7250



HEXAGONALES / HEXAGONALS / A SIX PANS / SECHSKANT / ESAGONALI / ZESKANT / HEXAGONAIS

| COD | D | L | A |  |  |
|-------|-------|-----|----|---|---|
| 63435 | 2,5mm | 100 | 8 | 35 | 10 |
| 63436 | 3mm | | | | |
| 63437 | 4mm | 115 | 10 | 69 | |
| 63438 | 6mm | 125 | | | |
| 63439 | 8mm | 150 | | | |
| 63440 | 10mm | 160 | 12 | 130 | |

DIN 7250

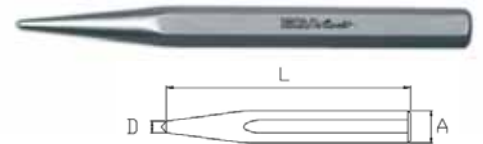



SET

| COD | D | |
|-------|-------|-------|
| 63765 | 63435 | 2,5mm |
| | 63436 | 3mm |
| | 63437 | 4mm |
| | 63438 | 6mm |
| | 63439 | 8mm |
| | 63440 | 10mm |



NEW



OCTOGONAL / OCTOGONAL / OCTOGONAL / OKTOGONAL / OTTAGONALE / OCTOGONAAL / OCTOGONAIS

| COD | D | L | A |  |  |
|-------|-------|-----|-----|---|---|
| 63441 | 2,5mm | 120 | 10 | 62 | 10 |
| 63442 | 3mm | | | 63 | |
| 63443 | 4mm | | | 65 | |
| 63445 | 8mm | | 12 | 94 | |
| 63446 | 10mm | | 106 | | |

Cr-V DIN 7250



CON MANGO / WITH HANDLE / AVEC MANCHE / MIT GRIFF / CON MANICO / MET HANDGRIEP / COM CABO

| COD | D | L | A |  |  |
|-------|-----|-----|----|---|---|
| 63466 | 2mm | 165 | 8 | 74 | 10 |
| 63467 | 3mm | | | 76 | |
| 63468 | 4mm | 175 | 10 | 114 | |
| 63469 | 5mm | | | 116 | |
| 63470 | 6mm | | | 118 | |
| 63471 | 8mm | 185 | 12 | 164 | |

Cr-V DIN 7250



SETS

CINCELES, BOTADORES Y GRANETES / CHISELS AND PUNCHES / BURINS, CHASSE-GOUPILLES ET POINTEAUX / MEIß EL UND DURCHSCHLÄGE / SCALPELLI E PUNZONI / BEITELS EN DOORSLAGERS / ESCOPROS, SACA-TROÇOS E PUNÇÕES



| COD | Composición / Composition | gr. |
|----------|---|-----|
| A- 69953 | Cinzel mecánico / Cold chisel: 15x12x150 & 11x10x130mm Butil plano / Crosscut chisel: 5x10x150mm Granete / Center punch: 3x10x120mm | 675 |
| B- 69954 | Botador cilíndrico / Pin punch: 4x10x130mm Botador cónico / Taper punch: 3x10x120mm | 700 |

BOTADORES CILÍNDRICOS / PIN PUNCHES / CHASSES GOUPILLES / DURCHSCHLÄGER / PUNZONE CILINDRICO / PENDRIJVERS PUNÇÕES CILÍNDRICOS



| COD | Composición / Composition | gr. |
|-------|---|-----|
| 69957 | 2,5x10x150 mm 3,5x10x150 mm 4,5x10x150 mm 6x10x150 mm 8x12x150 mm 10x12x150 mm | 525 |

SETS

BOTADORES CILÍNDRICOS / PIN PUNCHES / CHASSE GOUPILLES / DURCHSCHLÄGER / PUNZONE CILINDRICO / PENDRIJVERS PUNÇÕES CILÍNDRICOS



COD

Composición / Composition



| | | |
|--------------|--|-----|
| 69958 | 3x150 mm 4x150 mm 5x150 mm 6x150 mm 7x150 mm 8x150 mm | 725 |
|--------------|--|-----|

BOTADORES Y GRANETES / PUNCHES / CHASSE-GOUPILLES ET POINTEAUX / DURCHSCHLÄGE / PUNZONI / DOORSLAG SACA-TROÇOS E PUNÇÕES



COD

Composición / Composition



| | | |
|------------------|---|-----|
| A - 69955 | Botador cónico / Taper punch: 1x120mm Botador cónico / Taper punch: 2x120mm Botador cónico / Taper punch: 3x120mm | 725 |
| B - 69956 | Botador cónico / Taper punch: 4x120mm Botador cónico / Taper punch: 5x120mm Granete / Center punch: 4x120 mm | 750 |



*HERRAMIENTA PARA TUBO / PIPE TOOLS / OUTILLAGE TUBE / ROHR WERKZEUGE
FERRAMENTI PER TUBI / PIJPGEREEDSCHAP / FERRAMENTA PARA TUBOS*

PREMIO A LA MEJOR IDEA EN HERRAMIENTAS
BEST TOOL AWARD
PRIX A LA MEILLEURE IDÉE EN OUTILS



“CLUB DE INVENTORES ESPAÑOLES”



Medalla, Salon Internacional de la Invención, París 2004

Medal, International Inventors Competition, Paris 2004

Medaille, Salon International de L'Invention, Paris 2004



La rapidez y facilidad de uso con una mano de la llave para tubo Mastergrip, con capacidad para tubos de ½"-3/4"-1"-1.1/4"-1.1/2" y 2", ofrece una sujeción ideal para empalmar con gran eficacia tubos roscados. Su especial diseño robusto permite ser empleado en trabajos pesados.

The fast and easy one-hand operated Mastergrip pipe wrench with capacity for ½"-3/4"-1"-1.1/4"-1.1/2" and 2" pipes, provides also a ratchet function that makes threaded pipe fitting really efficient. Heavy duty type for the most demanding jobs.

La rapidité et la facilité d'utilisation avec une seule main de la cle à tube mastergrip, avec une capacité pour des tubes de ½ - ¾ - 1" - 1.1/4" - 1.1/2" et 2", offre une fixation idéale pour prendre avec une grande efficacité des tubes filetés. Sa conception robuste permet une utilisation pour des travaux lourds.

1 Su exclusivo diseño geométrico de lengua y postizo con un dentado especial permiten un agarre perfecto.

Designed with special teeth for the best pipe gripping effect.

La géométrie exclusive de la mâchoire et du bras de levier, pourvus d'une denture spéciale, permet une prise parfaite du tube, tout en donnant un effet cliquet.

3 Postizo con chaveta para soportar esfuerzos en ambos sentidos.

Heel jaw with sunk key to withstand efforts in both directions.

Bras de levier avec un axe pour supporter des forces des deux côtés.

5 Patente pendiente

Patent pending

Brevet en cours

2 Mango ergonómico de fundición de precisión de inmejorable atractivo.

Ergonomic handle in accurate casting make it unbeatably attractive.

Manche ergonomique en fonte de précision, ayant un parfait attrait.

4 Fácil amarre del tubo con una sola mano.

Easy one handed gripping.

Prise aisée du tube avec une seule main.

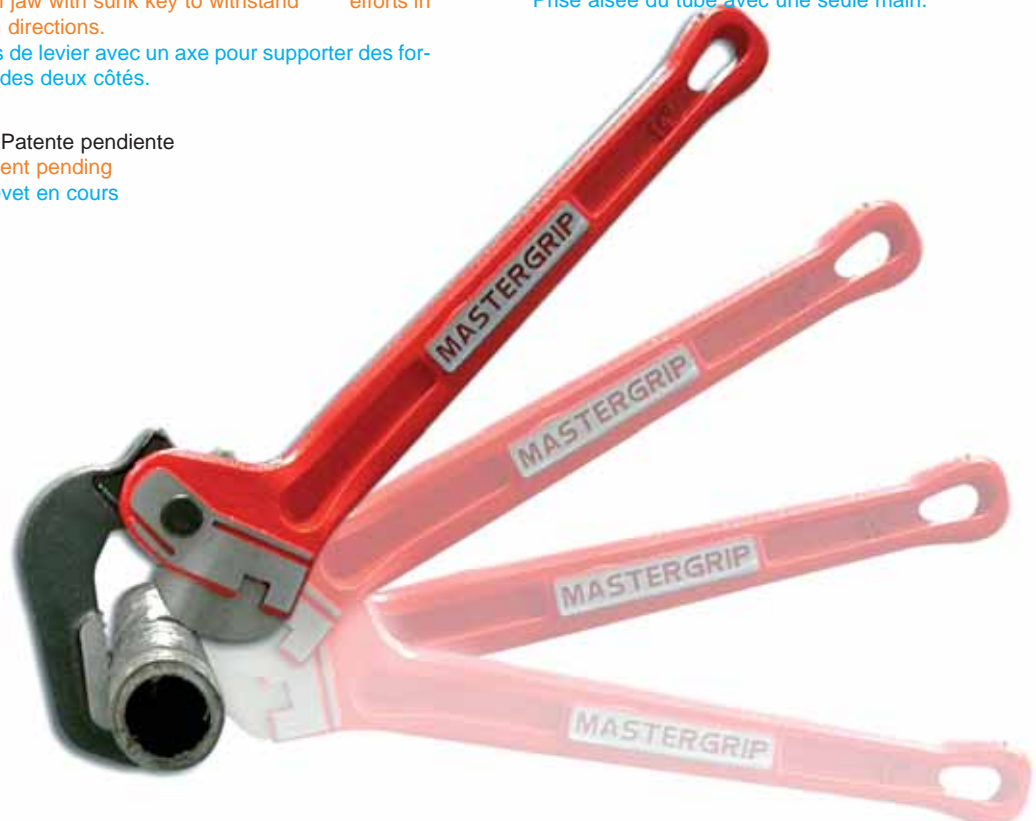

LLAVES PARA TUBO / PIPE WRENCHES / CLES SERRE-TUBES / EINHAND ROHRZANGE GIRATUBI PIJPTANG / CHAVES PARA TUBOS

MASTERGRIP

| COD | L | A | B | C | Hex Nuts | Cones | Washers | Nuts |
|-------|-----|------------|----|----|----------|-------|---------|------|
| 61405 | 10" | 1/4-1.1/2" | 15 | 26 | 13-40mm | 0,9 | | |
| 61406 | 14" | 1/2-2" | 23 | 33 | 17-50mm | 1,65 | 1 | 1 |

| COD | L | A | B | C | Hex Nuts | Cones | Washers | Nuts |
|-------|-----|---------|----|----|----------|-------|---------|------|
| 61407 | 18" | 1/2"-3" | 29 | 51 | 17-80mm | 2,5 | 1 | 1 |

REPUESTOS MASTERGRIP / MASTERGRIP SPARE PARTS / PIÈCES DE RECHANGE MASTERGRIP / MASTERGRIP ERSATZTEILE RICAMBI MASTERGRIP / MASTERGRIP ONDERDELEN / COMPONENTES MASTERGRIP

| Size | Heel Jaw | Hook Jaw | Spring | Axle | Description |
|------|----------|----------|--------|-------|---|
| 10" | 80326 | 80327 | 80324 | 80325 | Mordaza inferior / Heel Jaw / Machoire inférieure |
| 14" | 80329 | 80330 | 80315 | 80320 | Lengua / Hook Jaw / Bec |
| 18" | 80566 | 80567 | 80568 | 80569 | Muelle / Spring / Ressort |
| | | | | | Eje / Axle / Axe |

LLAVES STILLSON / STILLSON PIPE WRENCHES / CLES STILLSON / STILLSON ROHRZANGE / GIRATUBI MODELLO STILLSON PIJPTANG "STILLSON" / CHAVES STILLSON



REFORZADA / REINFORCED / RENFORCEE / VERSTARK / RINFORZATA / VERSTERKET / REFORÇADA

| COD | L | A | B | C | Cones | Washers | Nuts |
|-------|-----|------|--------|------|-------|---------|------|
| 61001 | 8" | 17,5 | 3/4" | 12,5 | 0,33 | | |
| 61002 | 10" | 23 | 1" | 15,6 | 0,65 | | |
| 61003 | 12" | 24,5 | 1.1/4" | 16 | 0,80 | 6 | 1 |
| 61004 | 14" | 28 | 1.1/2" | 20,6 | 1,15 | | |
| 61005 | 18" | 30 | 2" | 23,6 | 1,90 | | |
| 61006 | 24" | 39,5 | 2.1/2" | 27,1 | 3,10 | | |
| 61007 | 36" | 49,5 | 4" | 30 | 6,30 | 1 | - |

REPUESTOS LLAVE STILLSON / STILLSON WRENCH SPARE PARTS / PIECES DE RECHANGE CLE STILLSON / STIILLSON ROHR-
ZANGE ERSATZTEILEN / RICAMBI CHIAVI STILLSON / STILLSON PIJPTANG ONDERDELEN / COMPONENTES DE CHAVE STILSON



| | | | |
|-----|-------|-------|-------|
| 8" | 80047 | 80040 | 80033 |
| 10" | 80048 | 80041 | 80034 |
| 12" | 80049 | 80042 | 80035 |
| 14" | 80050 | 80043 | 80036 |
| 18" | 80051 | 80044 | 80037 |
| 24" | 80052 | 80045 | 80038 |
| 36" | 80053 | 80046 | 80039 |

| | |
|---|--|
|  | Juego muelles / Spring Set / Jeu de ressorts |
|  | Tuerca / Nut / Ecrou |
|  | Lengua / Hook Jaw / Bec |

LLAVE HEAVY DUTY / HEAVY DUTY PIPE WRENCH / CLE SERRE-TUBES HEAVY DUTY / ROHRZANGE HEAVY DUTY
GIRATUBI MODELLO AMERICANO PESANTE / VERSTERKTE PIJPTANG / CHAVE HEAVY DUTY

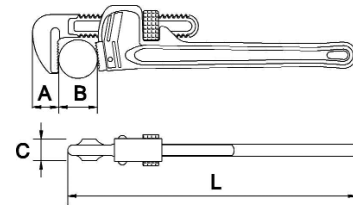

| COD | L | A | B | C | Kg. | | |
|-------|-----|------|--------|------|------|---|---|
| 61014 | 8" | 15 | 1" | 13,8 | 0,42 | 6 | 1 |
| 61015 | 10" | 20 | 1.1/2" | 17 | 0,83 | | |
| 61016 | 12" | 23 | 2" | 19,6 | 1,30 | | |
| 61017 | 14" | 25 | 2" | 22,8 | 1,70 | | |
| 61018 | 18" | 28 | 2.1/2" | 26 | 2,60 | | |
| 61019 | 24" | 33 | 3" | 28,8 | 4,50 | 1 | - |
| 61020 | 36" | 43 | 5" | 32,6 | 9,20 | | |
| 61021 | 48" | 57 | 6" | 35 | 14,2 | | |
| 61045 | 60" | 83,8 | 8" | 41 | 20 | | |

GGG-W-651-E, Type II Class A

REPUESTOS LLAVE HEAVY DUTY / HEAVY DUTY WRENCH SPARE PARTS / PIECES DE RECHANGE CLE HEAVY DUTY / HEAVY DUTY-
ROHRZANGE ERSATZTEILEN / RICAMBI CHIAVI HEAVY DUTY / HEAVY DUTY PIJPTANG ONDERDELEN / COMPONENTES DE
CHAVE HEAVY DUTY



| | | | | |
|-----|-------|-------|-------|-------|
| 8" | 81022 | 81015 | 81008 | 81001 |
| 10" | 81023 | 81016 | 81009 | 81002 |
| 12" | 81024 | 81017 | 81010 | 81003 |
| 14" | 81025 | 81018 | 81011 | 81004 |
| 18" | 81026 | 81019 | 81012 | 81005 |
| 24" | 81027 | 81020 | 81013 | 81006 |
| 36" | 81028 | 81021 | 81014 | 81007 |
| 48" | 81031 | 81030 | 81029 | 81000 |
| 60" | 81674 | 81672 | 81673 | 81671 |

| | |
|---|--|
|  | Juego muelles / Spring Set / Jeu de ressorts |
|  | Tuerca / Nut / Ecrou |
|  | Mordaza inferior / Heel Jaw Machoire inférieure |
|  | Lengua / Hook Jaw / Bec |

RAP

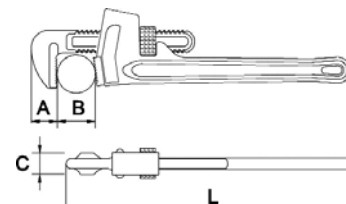

| COD | L | A | B | C | Kg. | | |
|-------|-----|----|--------|----|------|---|---|
| 61376 | 10" | 20 | 1.1/2" | 17 | 0,93 | 6 | 1 |

GGG-W-651-E, Type II Class A

LLAVE HEAVY DUTY CURVA / OFFSET HEAVY DUTY PIPE WRENCH / CLE SERRE-TUBES HEAVY DUTY COUDEE / ROHRZANGE GEKROEPT / GIRATUBI MODELLO AMERICANO CURVO / VERSTERKTE PIJPTANG-GEBOGEN / CHAVE HEAVY DUTY INCLINADA

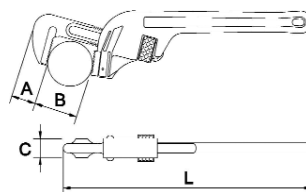

| COD | L | A | B | C | Kg. | | |
|-------|-----|----|--------|----|------|---|---|
| 61029 | 8" | 16 | 1" | 20 | 0,35 | | |
| 61030 | 10" | 20 | 1.1/2" | 23 | 0,80 | 6 | 1 |
| 61031 | 12" | 22 | 2" | 26 | 1,30 | | |
| 61032 | 14" | 25 | 2" | 29 | 1,54 | 3 | - |
| 61033 | 18" | 27 | 2.1/2" | 33 | 2,30 | | |
| 61034 | 24" | 31 | 3" | 35 | 4 | 1 | |

GGG-W-651-E, Type IV

PICO PATO / OFFSET PIPE WRENCH 90° / CLE SERRE-TUBE 90° / ROHRZANGE 90° / GIRATUBI 90° / PIJPTANG 90° / BICO PATO

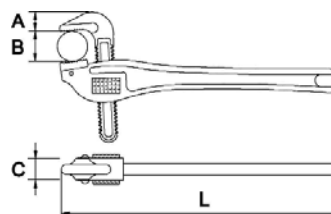

| COD | L | A | B | C | Kg. | | |
|-------|-----|----|--------|----|------|---|---|
| 61377 | 14" | 25 | 2" | 23 | 1,60 | 6 | 1 |
| 61378 | 18" | 29 | 2.1/2" | 26 | 2,70 | 2 | - |

GGG-W-651-E, Type II Class A

LLAVE DE ALUMINIO / ALUMINIUM PIPE WRENCH / CLE SERRE-TUBES EN ALLIAGE LEGER / ALUMINIUM ROHRZANGE / GIRATUBI MODELLO AMERICANO IM ALLUMINIO / LICHTMETALEN PIJPTANG / CHAVE ALUMINIO

TITALUM®

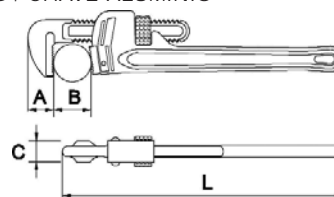

| COD | L | A | B | C | Kg. | | |
|-------|-----|----|--------|------|------|---|---|
| 61044 | 10" | 20 | 1.1/2" | 17 | 0,50 | 6 | 1 |
| 61023 | 12" | 23 | 2" | 19,6 | 0,78 | | |
| 61024 | 14" | 25 | 2" | 22,8 | 0,95 | 3 | - |
| 61025 | 18" | 28 | 2.1/2" | 26 | 1,64 | | |
| 61026 | 24" | 33 | 3" | 28,8 | 2,57 | 1 | - |
| 61027 | 36" | 43 | 5" | 32,6 | 4,96 | | |
| 61028 | 48" | 57 | 6" | 35 | 7,49 | | |

GGG-W-651-E, Type II Class C

PICO PATO DE ALUMINIO / ALUMINIUM OFFSET PIPE WRENCH 90° / CLE SERRE-TUBE 90° EN ALLIAGE LEGER / ROHRZANGE 90° ALUMINIUM / GIRATUBI 90° IM ALLUMINIO / LICHTMETALEN PIJPTANG 90° / BICO PATO ALUMINIO

TITALUM®

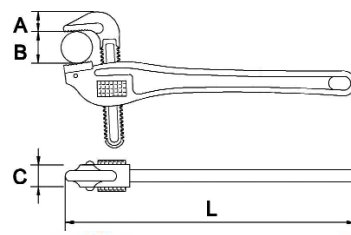

| COD | L | A | B | C | Kg. | | |
|-------|-----|----|--------|----|------|---|---|
| 61363 | 14" | 25 | 2" | 28 | 0,84 | 6 | 1 |
| 61364 | 18" | 28 | 2.1/2" | 39 | 1,28 | 2 | |
| 61365 | 24" | 34 | 3" | 42 | 2,25 | 1 | |

GGG-W-651-E, Type II Class C

LLAVE PARA TUBO TIPO BLITZ / BLITZ TYPE PIPE WRENCH / CLE SERRE-TUBE TYPE BLITZ / ROHRZANGE BLITZ
PIJPTANG TYPE BLITZ / GIRATUBI MODELLO BLITZ / CHAVE PARA TUBO MODELO BLITZ

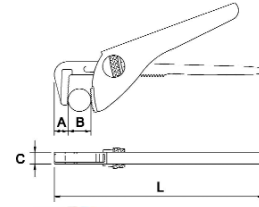

| COD | L | A | B | C | Kg. | | |
|-------|-------|----|--------|----|------|---|---|
| 61465 | 175mm | 19 | 1" | 12 | 0,33 | | |
| 61466 | 225mm | 20 | 1.1/2" | 15 | 0,56 | 6 | 1 |
| 61467 | 275mm | 21 | 2" | 16 | 0,78 | | |
| 61468 | 300mm | 23 | 2.1/2" | 17 | 1,05 | | |
| 61469 | 350mm | 24 | 3" | 17 | 1,10 | 2 | - |

LLAVE SPUD / SPUD PIPE WRENCH / CLE SPUD / VERSTELLBARE ROHRZANGE / GIRATUBI MODELLO SPUD
VERSTELLBARE PIJPTANG / CHAVE PARA TUBO SPUD

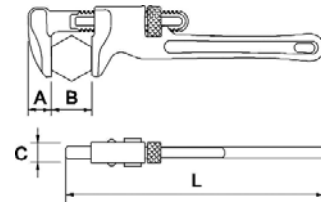

| COD | L | A | B | C | Kg. | | |
|-------|-----|------|--------|------|------|---|---|
| 61369 | 12" | 24,5 | 2.5/8" | 16,5 | 1,20 | 6 | 1 |

LLAVE HEXAGONAL / HEX PIPE WRENCH / CLE HEXAGONALE / ROHRZANGE SECHSKANT / GIRATUBI HEXAGONALE HEX PIJPTANG / CHAVE PARA TUBO HEXAGONAL

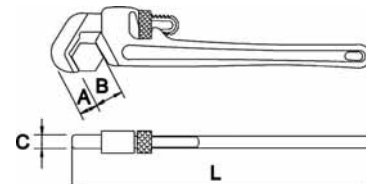

| COD | L | A | B | C | Kg. | | |
|-------|---------|----|------------|----|------|---|---|
| 61368 | 14.1/2" | 29 | 5/8-1.1/4" | 14 | 2,12 | 2 | 1 |

LLAVE HEXAGONAL CURVO / HEXAGONAL OFFSET PIPE WRENCH / CLE HEXAGONALE COUDEE/ ROHRZANGE GEKRÖPFT
GIRATUBI HEXAGONALE CURVO / PIJPTANG GEBOGEN / CHAVE HEXAGONAL INCLINADA

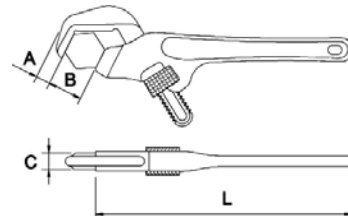

| COD | L | A | B | C | Kg. | | |
|-------|--------|----|---------------|-----|------|---|---|
| 61367 | 9.1/2" | 14 | 1.1/8"-2.5/8" | 9,5 | 0,74 | 6 | 1 |

LLAVES SUECAS / SWEDISH PIPE WRENCHES / CLES SERRE-TUBES SUEDOISES / ECKROHRZANGE GIRATUBI MOD. SUEDESE / PIJPTANG ZWEEDS MODEL / CHAVES PARA TUBOS SUECAS

SERIE MASTER Cr-V

LLAVE SUECA S 45° / SWEDISH PIPE WRENCH S 45° / CLE SERRE-TUBES SUEDOISE S 45° / ECKROHRZANGE S 45° GIRATUBI MOD. SUEDESE S 45° / PIJPTANG ZWEEDS MODEL S 45° / CHAVE SUECA S 45°

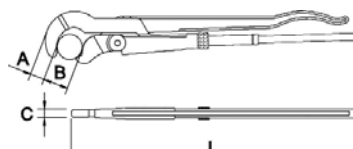

| COD | L | A | B | C | Kg | | |
|-------|-----|----|--------|-----|------|---|---|
| 61010 | 235 | 15 | 1/2" | 8,8 | 0,40 | 4 | |
| 61011 | 330 | 20 | 1" | 13 | 0,79 | 6 | 1 |
| 61012 | 425 | 26 | 1.1/2" | 14 | 1,43 | 4 | |
| 61013 | 535 | 28 | 2" | 16 | 2,37 | 2 | |
| 61022 | 648 | 35 | 3" | 19 | 4,16 | | |

Cr-V DIN 5234

LLAVE SUECA 45° / SWEDISH PIPE WRENCH 45° / CLE SERRE-TUBES SUEDOISE 45° / ECKROHRZANGE 45° GIRATUBI MOD. SUEDESE 45° / PIJPTANG ZWEEDS MODEL 45° / CHAVE SUECA 45°

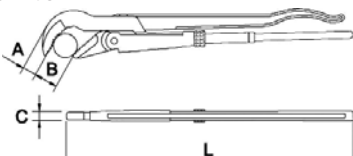

| COD | L | A | B | C | Kg | | |
|-------|-----|----|--------|-----|------|---|---|
| 61040 | 235 | 18 | 1/2" | 8,8 | 0,42 | 4 | |
| 61041 | 330 | 24 | 1" | 13 | 0,75 | 6 | 1 |
| 61042 | 425 | 27 | 1.1/2" | 14 | 1,40 | 4 | |
| 61043 | 535 | 33 | 2" | 16 | 2,32 | 2 | |

Cr-V DIN 5234

LLAVE SUECA 90° / SWEDISH PIPE WRENCH 90° / CLE SERRE-TUBES SUEDOISE 90° / ECKROHRZANGE 90° GIRATUBI MOD. SUEDESE 90° / PIJPTANG ZWEEDS MODEL 90° / CHAVE SUECA 90°

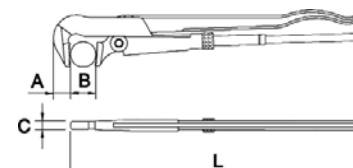

| COD | L | A | B | C | Kg | | |
|-------|-----|----|--------|----|------|---|---|
| 61046 | 320 | 18 | 1" | 15 | 0,73 | 6 | 1 |
| 61047 | 432 | 20 | 1.1/2" | 18 | 1,31 | 4 | |
| 61048 | 560 | 25 | 2" | 20 | 2,32 | 2 | |
| 61049 | 620 | 30 | 3" | 20 | 2,97 | | |

Cr-V DIN 5234

LLAVE SUECA BOCAS DE PLASTICO / FITTINGS WRENCH / MACHOIRES EN PLASTIQUE / ECKROHRZANGE / MIT KUNSTSTOFFBACKEN CON GANASCE IN PLASTICA / MET KUNSTOF BEK / CHAVE SUECA BOCAS DE PLASTICO

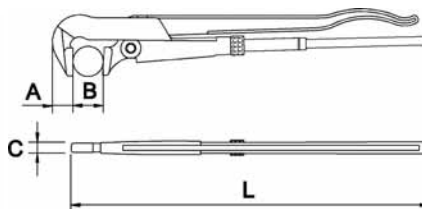

| COD | L | A | B | C | Kg | | | |
|-------|-----|----|----|-----|------|---|---|-------|
| 61050 | 315 | 21 | 1" | 9,5 | 0,79 | 6 | 1 | 64257 |

Cr-V DIN 5234

LLAVE SUECA BOCAS RECTAS / SWEDISH PIPE WRENCH STRAIGHT JAWS / CLE SERRE-TUBES SUEDOISE / ECKROHRZANGE GIRATUBI MOD. SUEDESE / PIJPTANG ZWEEDS / CHAVE SUECA RECTA

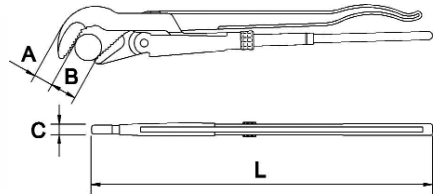

| COD | L | A | B | C | Kg | | |
|-------|-----|----|--------|----|------|---|---|
| 60963 | 320 | 24 | 1" | 13 | 0,75 | 6 | 1 |
| 60964 | 420 | 27 | 1.1/2" | 14 | 1,40 | 3 | - |
| 60965 | 560 | 33 | 2" | 16 | 2,32 | | |

Cr-V DIN 5234

LLAVE DE CADENA REVERSIBLE / REVERSIBLE CHAIN PIPE WRENCH / CLE A CHAINE REVERSIBLE / KETTENROHRZANGE
CHIAVE A CATENA REVERSIBILE / KETTINGTANG / CHAVE CORRENTE REVERSIVEL

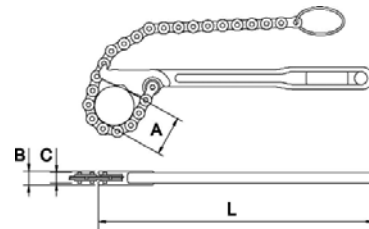

| COD | L | A | B | C | Kg | | |
|-------|-----|----|------|----|------|---|-------|
| 61035 | 300 | 4" | 19,5 | 19 | 0,82 | 6 | 64038 |

LLAVE DE CADENA REVERSIBLE REFORZADA / HEAVY DUTY REVERSIBLE CHAIN PIPE WRENCH / CLE A CHAINE REVERSIBLE RENFORCEE / KETTENROHRZANGE VERSTÄRKT / CHIAVE A CATENA REVERSIBILE RINFORZATA / KETTINGTANG ZWAAR MODEL
CHAVE CORRENTE REVERFORÇADA

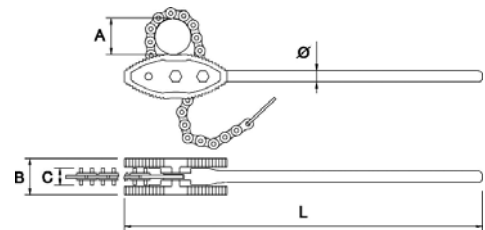

| COD | L | A | B | C | Kg | | |
|-------|------|-----|----|----|-------|---|-------|
| 61036 | 900 | 4" | 64 | 36 | 5,71 | 1 | 64081 |
| 61037 | 900 | 6" | 66 | 36 | 6,60 | | 64082 |
| 61038 | 1100 | 8" | 69 | 36 | 11,80 | | 64083 |
| 61039 | 1100 | 10" | 71 | 36 | 13 | | 64084 |
| 61138 | 1300 | 12" | 71 | 36 | 16,80 | | 64128 |
| 61139 | 1300 | 16" | 71 | 36 | 19 | | 64129 |

LLAVE DE CORREA / STRAP WRENCH / CLE A SANGLE / GURTROHRZANGE / GIRATUBI A NASTRO / BANDTANG
CHAVE DE CORREIA

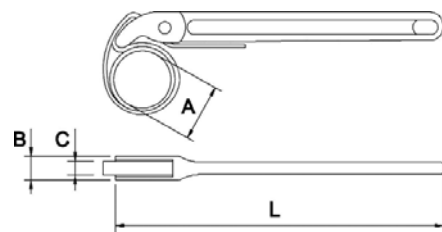

| COD | L | A | B | C | Kg | | |
|-------|------|----|----|----|------|---|---|
| 61480 | 450 | 3" | 43 | 27 | 0,33 | 6 | 1 |
| 61481 | 1000 | 8" | 43 | 27 | 0,34 | | |

TERRAJAS AJUSTABLES / ADJUSTABLE THREADERS / FILIERES AJUSTABLES / GEWINDESCHNEIDKLUPPE, VERSTELLBAR
FILIERA REGOLABILE VERSTELBAAR DRAADSNUIJKOP / TARRACHAS AJUSTAVEIS

kit

| BSPT | COD | NPT | | Kg. | | |
|-------|-----|-------|--------|------|---|--|
| 63160 | | 63162 | 1/4-2" | 10,4 | 1 | |
| 63161 | | 63163 | 1/2-2" | 10 | | |



PEINES / DIES / PEIGNES / SCHNEIDBACKEN / PETTINI / SNIJMESSEN / CAÇONETES

| BSPT | NPT | | Kg. | | |
|-------|-------|----------|------|---|--|
| 64338 | 64342 | 1/4-3/8" | 0,40 | 1 | |
| 64339 | 64343 | 1/2-3/4" | 0,41 | | |
| 64340 | 64344 | 1-1.1/4" | 0,36 | | |
| 64341 | 64345 | 1.1/2-2" | 0,31 | | |



kit

| BSPT | COD | NPT | | Kg. | | |
|-------|-----|-------|----------|------|---|--|
| 63164 | | 63166 | 1.1/2-4" | 22,4 | 1 | |
| 63165 | | 63167 | 2.1/4-4" | 21,5 | | |



PEINES / DIES / PEIGNES / SCHNEIDBACKEN / PETTINI / SNIJMESSEN / CAÇONETES

| BSPT | NPT | | Kg. | | |
|-------|-------|----------|------|---|--|
| 64346 | 64349 | 1.1/2-2" | 0,88 | 1 | |
| 64347 | 64350 | 2.1/4-3" | 0,88 | | |
| 64348 | 64351 | 3.1/2-4" | 0,70 | | |



CABEZAS / HEADS / TÊTES / SCHNEIDKÖPFE / TESTE / DRAADSNUIJKOPPEN / CABEÇAS

| BSPT | COD | NPT | BSPP | | Kg. | | | | | |
|-------|-------|-----|-------|--------|------|---|---|--|---|---|
| 63001 | 63011 | | 63723 | 1/4" | 0,64 | 1 | 1 | | | |
| 63002 | 63012 | | 63724 | 3/8" | 0,59 | | | | | |
| 63003 | 63013 | | 63725 | 1/2" | 0,64 | | | | | |
| 63004 | 63014 | | 63726 | 3/4" | 0,55 | | | | | |
| 63005 | 63015 | | 63727 | 1" | 0,81 | | | | | |
| 63006 | 63016 | | 63728 | 1.1/4" | 0,92 | | | | | |
| 63007 | 63017 | | - | 1.1/4" | 1,50 | | | | | |
| 63008 | 63018 | | 63730 | 1.1/2" | 1,92 | | | | - | - |
| 63009 | 63019 | | 63731 | 2" | 1,88 | | | | - | - |



PEINES / DIES / PEIGNES / SCHNEIDBACKEN / PETTINI / SNIJMESSEN / CAÇONETES

| BSPT | COD | NPT | BSPP | | Kg. | | | | | |
|-------|-------|-----|-------|--------|------|---|---|--|---|---|
| 63040 | 63050 | | 64487 | 1/4" | 0,64 | 1 | 1 | | | |
| 63041 | 63051 | | 64488 | 3/8" | 0,59 | | | | | |
| 63042 | 63052 | | 64489 | 1/2" | 0,64 | | | | | |
| 63043 | 63053 | | 64490 | 3/4" | 0,55 | | | | | |
| 63044 | 63054 | | 64491 | 1" | 0,81 | | | | | |
| 63045 | 63055 | | 64492 | 1.1/4" | 0,92 | | | | | |
| 63046 | 63056 | | 64493 | 1.1/2" | 1,50 | | | | - | - |
| 63047 | 63057 | | 64494 | 2" | 1,92 | | | | - | - |



CARRACAS / RATCHET / CLIQUETS / RATSCHENHEBEL / CRICCO DI MANOURA / RATEL / ROQUETES

| COD | L | Kg. | | |
|-------|---------------|------|---|---|
| 63000 | 1/4" ÷ 1.1/4" | 1,55 | 1 | 1 |
| 63010 | 1.1/4" ÷ 2" | 3 | | |



REDUCTOR / ADAPTOR / ADAPTATEUR / ADAPTER / RIDUTTORE / ADAPTER / REDUTOR

| COD | CAP | gr. | |
|-------|---------------|-------|---|
| 80833 | 1/4" ÷ 1.1/4" | 15 gr | 1 |



ACEITE DE CORTE / CUTTING OIL / HUILE DE COUPE / GEWINDESCHNEIDMITTEL / OLIO DA TAGLIO / DRAADSNIOJLE / OLEO DE CORTE

| COD | CAP ml. | |
|-------|---------|---|
| 64007 | 60 | 1 |



TERRAJA DE CABEZAS INTERCAMBIABLES / DROP HEAD THREADER / FILIERES A TÊTES INTERCHANGEABLES / SET GEWINDESCHNEIDKLUPPEN / FILIERE A TESTA / DRAADSNIJSETS / TARRACHAS DE CABEÇAS INTERMUTAVEIS

| BSPT | COD NPT | BSPP | | | | | Kg. |
|-------|---------|-------|---------------|---|-------|-------|------|
| 63020 | 63026 | 63032 | 1/4" ÷ 1.1/4" | 6 | 63000 | 51000 | 7,5 |
| 63021 | 63027 | 63033 | 3/8" ÷ 1.1/4" | 5 | | | 6,80 |
| 63022 | 63028 | 63034 | 1/2" ÷ 1.1/4" | 4 | | | 6,30 |
| 63023 | 63029 | 63035 | 1/4" ÷ 1" | 5 | | | 6,60 |
| 63024 | 63030 | 63048 | 3/8" ÷ 1" | 4 | | | 6 |
| 63025 | 63031 | 63049 | 1/2" ÷ 1" | 3 | | | 5,70 |



| BSPT | COD NPT | BSPP | | | | | Kg. |
|-------|---------|-------|-------------|---|-------|-------|------|
| 63036 | 63038 | 63058 | 1.1/4" ÷ 2" | 3 | 63010 | 51001 | 9,8 |
| 63037 | 63039 | 63059 | 1.1/2" ÷ 2" | 2 | | | 8,40 |



| BSPT | COD NPT | BSPP | | | | | Kg. |
|-------|---------|-------|-----------|---|-------|-------|-------|
| 63134 | 63139 | 63072 | 1/4" ÷ 2" | 8 | 63010 | 50002 | 14,20 |
| 63133 | 63138 | 63073 | 3/8" ÷ 2" | 7 | | | 13,60 |
| 63132 | 63137 | 63074 | 1/2" ÷ 2" | 6 | | | 12,5 |



MASTERKIT - 1

| COD | | | | | | | | | | | | | Kg |
|-------|--|---------|-----|-----|----|-----|----|--|--|--|--|--|------|
| 69000 | | 1/2"-1" | 14° | 14° | 1° | 10° | 2° | | | | | | 9,9 |
| 69001 | | BSPT | | | | | | | | | | | 10,4 |
| 69002 | | | | | | | | | | | | | 9,35 |
| 69021 | | NPT | | | | | | | | | | | 10,4 |
| 69787 | | | | | | | | | | | | | 9,9 |
| 69788 | | BSPP | | | | | | | | | | | 10,4 |
| 69789 | | | | | | | | | | | | | 9,35 |



MASTERKIT - 2

| COD | | | | | | | | | | | | | Kg |
|-------|--|---------|-----|-----|----|-----|----|--|--|--|--|--|------|
| 69050 | | 1/2"-2" | 14° | 14° | 1° | 10° | 2° | | | | | | 16,5 |
| 69051 | | BSPT | | | | | | | | | | | 17 |
| 69052 | | | | | | | | | | | | | 16 |
| 69072 | | NPT | | | | | | | | | | | 17 |
| 69790 | | | | | | | | | | | | | 16,5 |
| 69791 | | BSPT | | | | | | | | | | | 17 |
| 69792 | | | | | | | | | | | | | 16 |



TERRAJAS TIPO ARMSTRONG / ARMSTRONG TYPE THREADERS / FILIERES MOD. ARMSTRONG / SET GEWINDESCHNEIDKLUPPEN TYP ARMSTRONG / FILIERA TIPO ARMSTRONG / DRAADSNIJSET TYPE ARMSTRONG / TARRACHAS TIPO ARMSTRONG

| BSPT | COD | NPT | | | | | | Kg |
|-------|-------|-------------|---|--|--|-------|--|------|
| 69130 | 69145 | 1/4"÷1.1/4" | 6 | | | | | 5,50 |
| 69131 | 69146 | 3/8"÷1.1/4" | 5 | | | | | 5,29 |
| 69132 | 69147 | 1/2"÷1.1/4" | 4 | | | | | 5,08 |
| 69133 | 69148 | 1/4"÷1" | 5 | | | 63069 | | 5,30 |
| 69134 | 69149 | 3/8"÷1" | 4 | | | | | 5,09 |
| 69135 | 69150 | 1/2"÷1" | 3 | | | | | 4,95 |



| BSPT | COD | NPT | | | | | | Kg |
|-------|-------|-----------|---|--|--|-------|--|------|
| 69136 | 69151 | 1/2"÷2" | 6 | | | | | 7,30 |
| 69137 | 69152 | 3/4"÷2" | 5 | | | | | 8,38 |
| 69138 | 69153 | 1"÷2" | 4 | | | 63070 | | 7,84 |
| 69139 | 69154 | 1.1/4"÷2" | 3 | | | | | 7,30 |



COJINETES / DIES / COUSSINETS / NÄHKISSEN / CUSCINETTI / SNIJMESSEN / CAÇONETES

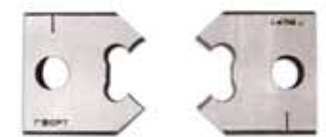

| COD | |  |  |  |
|-------|-------|---|---|---|
| BSPT | NPT | | | |
| 64010 | 64022 | 1/4" | 260 | 1 |
| 64011 | 64023 | 3/8" | 255 | |
| 64012 | 64024 | 1/2" | 230 | |
| 64013 | 64025 | 3/4" | 235 | |
| 64014 | 64026 | 1" | 210 | |
| 64015 | 64027 | 1.1/4" | 175 | |



| COD | |  |  |  |
|-------|-------|---|---|---|
| BSPT | NPT | | | |
| 64016 | 64028 | 1/2" | 555 | 1 |
| 64017 | 64029 | 3/4" | 545 | |
| 64018 | 64030 | 1" | 500 | |
| 64019 | 64031 | 1.1/4" | 450 | |
| 64020 | 64032 | 1.1/2" | 400 | |
| 64021 | 64033 | 2" | 310 | |





CARRACAS / RATCHET / CLIQUETS / RATSCHENHEBEL / CRICCO DI MANOURA / RATEL / ROQUETES

| COD | |  |  |  |
|-------|-------------|---|---|---|
| 63069 | 1/4"÷1.1/4" | | | |
| 63070 | 1/2"÷2" | 4,17 | 1 | |





TERRAJAS TIPO REED / REED TYPE THREADERS / FILIERES A COUSSINETS CARRES / TYPE REED / FILIERA TIPO REED / DRAADSNIJSET TYPE REED / TARRACHAS CAÇONETE QUADRADO

| COD | |  |  |
|-------|-------|---|---|
| BSPT | NPT | | |
| 69160 | 69163 | 1/4"÷1" | 5,27 |
| 69161 | 69164 | 3/8"÷1" | 5 |
| 69162 | 69165 | 1/2"÷1" | 4,72 |



COJINETES / DIES / COUSSINETS / NÄHKISSEN / CUSCINETTI / SNIJMESSEN / CAÇONETES

| COD | |  |  |  |
|-------|-------|---|---|---|
| BSPT | NPT | | | |
| 64040 | 64046 | 1/4" | 265 | 1 |
| 64041 | 64047 | 3/8" | 210 | |
| 64042 | 64048 | 1/2" | 220 | |
| 64043 | 64049 | 3/4" | 210 | |
| 64044 | 64050 | 1" | 240 | |



CARRACAS / RATCHET / CLIQUETS / RATSCHENHEBEL / CRICCO DI MANOURA / RATEL / ROQUETES

| COD | |  |  |  |
|-------|---------|---|---|---|
| 63075 | 1/4"÷1" | | | |



CORTATUBOS DE ACERO / STEEL PIPE CUTTER / COUPE-TUBES ACIER / ROHRABSCHNEIDER / TAGLIATUBI PER FERRO
BUIZENSNIJDER / CORTA TUBOS AÇO

ACERO / STEEL / ACIER

| COD | | Kg. | | |
|-------|-------------|-----|---|-------|
| 63171 | 1/8"÷1.1/4" | 1,1 | 2 | 63103 |
| 63172 | 1/8"÷2" | 2,5 | 1 | 63101 |

ACERO INOXIDABLE / STAINLESS STEEL / ACIER INOXYDABLE

| COD | | Kg. | | |
|-------|-------------|-----|---|-------|
| 63098 | 1/8"÷1.1/4" | 1,1 | 2 | 63090 |
| 63099 | 1/8"÷2" | 2,5 | 1 | 63091 |

ACERO / STEEL / ACIER

| COD | | Kg. | | |
|-------|---------|------|---|-------|
| 63366 | 1/8"÷2" | 3,25 | 1 | 63101 |
| 63193 | 1"÷3" | 5 | | 63195 |

ACERO INOXIDABLE / STAINLESS STEEL / ACIER INOXYDABLE

| COD | | Kg. | | |
|-------|---------|------|---|-------|
| 63378 | 1/8"÷2" | 3,25 | 1 | 63091 |
| 63194 | 1"÷3" | 5 | | 63092 |

ACERO / STEEL / ACIER

| COD | | Kg. | | |
|-------|-------|------|---|-------|
| 63175 | 2"÷4" | 8,10 | 1 | 63185 |

ACERO INOXIDABLE / STAINLESS STEEL / ACIER INOXYDABLE

| COD | | Kg. | | |
|-------|-------|------|---|-------|
| 63177 | 2"÷4" | 8,10 | 1 | 63186 |



CORTATUBOS ARTICULADO / HINGED PIPE CUTTER / COUPE TUBE ARTICULES / UNIVERSAL ROHRABSCHNEIDER
TAGLIATUBI ARTICOLATO / OPENSLEANDE PIJPSNIJDER / CORTA TUBOS ARTICULADO

ACERO / STEEL / ACIER

| COD | | Kg. | | |
|-------|--------|-----|---|-------|
| 63355 | 2"÷4" | 6 | 1 | 64173 |
| 63356 | 4"÷6" | 9 | | 64174 |
| 63357 | 6"÷8" | 11 | | 64175 |
| 63358 | 8"÷12" | 16 | | 64176 |

ACERO INOXIDABLE / STAINLESS STEEL / ACIER INOXYDABLE

| COD | | Kg. | | |
|-------|--------|-----|---|-------|
| 63359 | 2"÷4" | 6 | 1 | 64196 |
| 63360 | 4"÷6" | 9 | | 64197 |
| 63361 | 6"÷8" | 11 | | 64198 |
| 63362 | 8"÷12" | 16 | | 64199 |



HIERRO DUCTIL Y FUNDICION / CAST AND DUCTILE IRON /

| COD | | Kg. | | |
|-------|--------|-----|---|-------|
| 63772 | 2"÷4" | 6 | 1 | 64654 |
| 63773 | 4"÷6" | 9 | | 64655 |
| 63774 | 6"÷8" | 11 | | 64655 |
| 63775 | 8"÷12" | 16 | | 64655 |



CORTAMATIC - 12

CORTATUBOS PROPULSADO / POWER PIPE CUTTER / COUPE TUBE ELECTRIQUE / ELEKTRO-ROHRABSCHNEIDER / TAGLIATUBI ALIMENTATO / ELEKTRISCHE PIJPSNIJDER / CORTA TUBOS ELECTRO-HIDRAULICO

| COD | CAP | Kg. | |
|-------|------------|------|---|
| 60002 | 2.1/2"-12" | 66,6 | 1 |



TORNILLO DE BANCO PARALELO CON MORDAZAS PARA TUBO / PARALLEL PIPE VICE WITH PIPE JAWS / ETAU A MORS PARALLELES AVEC SERRE TUBE / PARALLELSCHRAUBSTOCK MIT ROHRSPANNBACKEN / MORSA PARALLELA CON GANASCE PER TUBI BANKSCHROEF MET PARALLELE BEKKEN VAST MODEL MET PIJPENKLEM / TORNO PARALELO CON MORDAÇAS PARA TUBO

FIJO / FIXED / FIXE / FESTE-AUSFÜHRUNG / VAST / BASE FISSA / FIXO

| COD | | | INCH | N | Kg. | |
|-------|----|-----|---------|--------|------|---|
| 69630 | 4" | 110 | 1/4"÷2" | 15.000 | 5,5 | 1 |
| 69631 | 5" | 150 | 1/2"÷2" | 25.000 | 11,5 | |
| 69632 | 6" | 225 | 1/2"÷3" | 35.000 | 24,8 | |
| 69633 | 7" | | | 50.000 | 26 | |

ACERO FORJADO / FORGED STEEL / ACIER FORGÉ



GIRATORIO / SWIVEL / TOURNANT / DREHBARE AUSFÜHRUNG / DRAAISTAND / BASE GIRATORIA

| COD | | | INCH | N | Kg. | |
|-------|----|-----|---------|--------|------|---|
| 69634 | 4" | 110 | 1/4"÷2" | 15.000 | 6,2 | 1 |
| 69635 | 5" | 150 | 1/2"÷2" | 25.000 | 13,5 | |
| 69636 | 6" | 225 | 1/2"÷3" | 35.000 | 27,8 | |
| 69637 | 7" | | | 50.000 | 29 | |

ACERO FORJADO / FORGED STEEL / ACIER FORGÉ



| COD | | Kg. |
|-------|----|------|
| 81036 | 4" | 0,63 |
| 81037 | 5" | 1,62 |
| 81038 | 6" | 2,96 |
| 81039 | 7" | |



| COD | |
|-------|----|
| 80079 | 4" |
| 80080 | 5" |
| 80081 | 6" |
| 80082 | 7" |



La más galardonada
The most awarded
La plus primée

TORNILLO DE BANCO PARALELO AJUSTE RÁPIDO / QUICK ACTION PARALLEL BENCH VICE / ETAU PARALLELE AVEC REGLAGE RAPIDE / SCHNELLVERSTELLBARE PARRALLELSCHRAUBSTOCK / MORSA DA BANCO AZIONE RAPIDA / SNELVERSTELBARE PARALLEL BANKSCHROEF / TORNO DE BANCADA PARALELO AJUSTE RÁPIDO



ACCIÓN RÁPIDA
QUICK ACTION
REGLAGE RAPIDE

FIJO / FIXED / FIXE / FESTE-AUSFÜHRUNG / VAST / BASE FISSA / FIXO

| COD | | | N | Kg. | |
|-------|----|-----|--------|------|---|
| 69724 | 4" | 110 | 15.000 | 9,4 | 1 |
| 69725 | 5" | 150 | 25.000 | 13,4 | |

ACERO FUNDIDO / CAST STEEL / FONTE D'ACIER



ACCIÓN RÁPIDA / QUICK ACTION / REGLAGE RAPIDE

GIRATORIO / SWIVEL / TOURNANT / DREHBARE AUSFÜHRUNG / DRAAISTAND / BASE GIRATORIA

| COD | | | N | Kg. | |
|-------|----|-----|--------|------|---|
| 69709 | 4" | 110 | 15.000 | 10,8 | 1 |
| 69710 | 5" | 150 | 25.000 | 15,3 | |

ACERO FUNDIDO / CAST STEEL / FONTE D'ACIER



ACCIÓN RÁPIDA / QUICK ACTION / REGLAGE RAPIDE

| COD | | |
|-------|----|-----|
| 82751 | 4" | 1,4 |
| 82752 | 5" | 1,9 |



| COD | |
|-------|----|
| 80761 | 4" |
| 80762 | 5" |



TORNILLO DE BANCO PARALELO / PARALLEL BENCH VICE / ETAU A MORS PARALLELES / PARALLELSCHRAUBSTÖCKE / MORSA DA BANCO PARALLELA / BANKSCHROEF MET PARALLELE BEKKEN-VAST MODEL / TORNO DE BANCADA PARALELO

FIJO / FIXED / FIXE / FESTE-AUSFÜHRUNG / VAST / BASE FISSA / FIXO

| COD | | | N | Kg. | |
|-------|----|-----|--------|------|---|
| 69592 | 4" | 110 | 15.000 | 9,4 | 1 |
| 69593 | 5" | 150 | 25.000 | 13,4 | |
| 69594 | 6" | 225 | 35.000 | 22 | |
| 69595 | 8" | | 50.000 | 29 | |

ACERO FUNDIDO / CAST STEEL / FONTE D'ACIER



GIRATORIO / SWIVEL / TOURNANT / DREHBARE AUSFÜHRUNG / DRAAISTAND / BASE GIRATORIA

| COD | | | N | Kg. | |
|-------|----|-----|--------|------|---|
| 69596 | 4" | 110 | 15.000 | 10,8 | 1 |
| 69597 | 5" | 150 | 25.000 | 15,3 | |
| 69598 | 6" | 225 | 35.000 | 24 | |
| 69599 | 8" | | 50.000 | 31 | |

ACERO FUNDIDO / CAST STEEL / FONTE D'ACIER



| COD | | |
|-------|----|-----|
| 81961 | 4" | 1,4 |
| 81962 | 5" | 1,9 |
| 81963 | 6" | 2 |
| 81964 | 8" | |



| COD | |
|-------|----|
| 80749 | 4" |
| 80750 | 5" |
| 80751 | 6" |
| 80752 | 8" |



12

HERRAMIENTA PARA TUBO / PIPE TOOLS / OUTILLAGE TUBE / ROHR WERKZEUGE FERRAMENTI PER TUBI / PIJGEREEDSCHAP / FERRAMENTA PARA TUBOS

TORNILLO DE BANCO PARA TUBOS / PIPE VICE / ÉTAU À CHARNIÈRE / ROHRSCHRAUBSTOCK / MORSA PER TUBI / BANKSCHROEF / TORNO PARA TUBOS

| COD | INCH | mm | Kg. | |
|-------|---------|--------|------|---|
| 61202 | 1/8"÷2" | 10-60 | 4 | 1 |
| 61204 | 1/8"÷3" | 10-89 | 8 | |
| 61205 | 1/8"÷4" | 10-114 | 11,7 | |

| COD | | COD | | COD | |
|-------|----|-------|----|-------|----|
| 64260 | 2" | 64352 | 3" | 64258 | 4" |
| 64261 | | 64353 | | 64259 | |



TORNILLO DE BANCO PARA TUBOS PORTATIL / PORTABLE PIPE VICE / ÉTAU À TUBES PROTABLE / TRAGBARE ROHRSCHRAUBSTOCK / MORSA DA BANCO PER TUBI PORTATILI / DRAAGBARE PIJPKLEM / TORNO DE BANCADA PARA TUBO PORTÁTIL

| COD | INCH | mm | Kg. | |
|-------|---------|-------|-----|---|
| 61199 | 1/8"÷2" | 10-60 | 5,5 | 1 |



MORDAZA DE CADENA / CHAIN VICE / ÉTAU A CHAÎNE / KETTENROHRSCHRAUBSTOCK / MORSA A CATENA / KETTINGKLEM
TORNOS DE CORRENTE

| COD | | Kg. | |
|-------|----|------|---|
| 61206 | 6" | 11,8 | 1 |



TRISTAND

| COD | INCH | mm | Kg. | |
|-------|--------|--------|-----|---|
| 61200 | 1/8-6" | 10-168 | 21 | 1 |

Con mordaza de cadena / With chain vice / Avec etau a chaîne



MESA DE TRABAJO / WORK BENCH / TABLE DE MONTEUR / ARBEITSTISCH / WERKTADEL / MESAS DE TRABALHO

| COD | | | Kg. |
|-------|---|--------------|-----|
| 61197 | A | 710x450x825 | 18 |
| 61198 | B | 1075x625x825 | 40 |
| 61196 | | 1200x625x825 | 37 |



CURVATUBOS HIDRAULICO / HYDRAULIC PIPE BENDER / CINTREUSE HYDRAULIQUE / HYDRAULIK-ROHRBIEGER
CURVATUBI IDRAULICO / HYDRAULISCH BUIGAPPARAAT / CURVADORAS HYDRAULICAS PARA TUBOS

CURVAMATIC - 2

| COD | | TONS. | | |
|-------|---------|-------|----|---|
| 60015 | 1/4"÷2" | 10 | 60 | 1 |

| COD | | | | |
|-------|------------------|-----|-------|---|
| 64190 | 1/4", 3/8", 1/2" | 86 | 0,80 | 1 |
| 64191 | 3/4" | 108 | 1,10 | |
| 64192 | 1" | 135 | 1,150 | |
| 64193 | 1.1/4" | 170 | 2,40 | |
| 64194 | 1.1/2" | 193 | 3 | |
| 64195 | 2" | 242 | 5,22 | |



CURVAMATIC - 3

| COD | | TONS. | | |
|-------|---------|-------|-----|---|
| 60016 | 1/4"÷3" | 13 | 125 | 1 |

| COD | | | | |
|-------|------------------|-----|-------|---|
| 64190 | 1/4", 3/8", 1/2" | 86 | 0,80 | 1 |
| 64191 | 3/4" | 108 | 1,10 | |
| 64192 | 1" | 135 | 1,150 | |
| 64193 | 1.1/4" | 170 | 2,40 | |
| 64194 | 1.1/2" | 193 | 3 | |
| 64195 | 2" | 242 | 5,22 | |
| 64231 | 2.1/2" | 303 | 16,50 | |
| 64232 | 3" | 358 | 22 | |



Su especial e innovador sistema de válvula 2-VELO permite de forma automática una rápida aproximación así como un suave doblado sin necesidad de cambiar de pistón.

The special and innovative 2-VELO valve system enables automatically fast pre-loading together with a soft bending without any need to change pistons.

Son système spécial et innovateur de clapet 2-VELO permet un réglage automatique et progressif , sans avoir besoin de changer de piston.



BOMBAS DE COMPROBACIÓN / TESTING PUMPS / POMPES D'EPREUVE / PRÜFPUMPE POMPI PROVA IMPIANTI / TESTPOMPS / BOMBAS DE COMPROVAÇÃO

ELECTRICA / ELECTRIC / ELECTRIQUE / ELEKTRISCH / ELETTRICA / ELECTRISCH
MASTERPUMP

| COD | CAP. | W | V | MAX PSI | INCH | Kg | BOX |
|-------|--------|------|-----|------------|------|----|-----|
| 60223 | 7L/min | 1750 | 230 | 60=860Psi | 1/2" | 14 | 1 |
| 60225 | | | 110 | | | | |



ELECTRICA / ELECTRIC / ELECTRIQUE / ELEKTRISCH / ELETTRICA / ELECTRISCH
SERIE CLASSIC

| COD | CAP. | W | V | MAX PSI | INCH | Kg | BOX |
|-------|--------|-----|-----|------------|------|----|-----|
| 60266 | 3L/min | 250 | 230 | 60=860Psi | 1/4" | 11 | 1 |
| 60267 | | | 110 | | | | |



BOMBAS DE COMPROBACIÓN / TESTING PUMPS / POMPES D'EPREUVE / PRÜFPUMPE / POMPES PROVA IMPIANTI / TESTPOMPS
BOMBAS DE COMPROVAÇÃO

| COD | Vol. l. | MAX PSI | INCH | Kg | BOX |
|-------|------------|-------------|------|----|-----|
| 60005 | 10 | 60=860Psi | 1/2" | 8 | 1 |
| 60009 | | 100=1440Psi | | | |



| COD | Vol. l. | MAX PSI | INCH | Kg | BOX |
|-------|------------|-------------|------|----|-----|
| 60011 | 10 | 60=860Psi | 1/2" | 8 | 1 |
| 60012 | | 100=1440Psi | | | |

ACERO INOXIDABLE / STAINLESS STEEL / ACIER INOXIDABLE / EDELSTAHL
ACCIAIO INOX / AÇO INOXIDAVEL



| COD | Vol. l. | MAX PSI | INCH | Kg | BOX |
|-------|------------|-------------|------|----|-----|
| 60006 | 10 | 60=860Psi | 1/2" | 9 | 1 |
| 60010 | | 100=1440Psi | | | |





**INSPECCION Y DESATASCADORES / DRAIN CLEANING AND INSPECTION
INSPECTION ET DEBOUCHEURS / ROHRINSPEKTION / ISPEZIONE E STURATORE
LEIDINGINSPECTIE / INSPECÇÃO E DESENTUPIDORES**



20

Ø de tubo / Pipe Ø / Ø de tube

600

| | |
|-------|-------|
| 60290 | |
| 60292 | |
| 60294 | |
| 60296 | |
| 60040 | |
| 60280 | |
| 60288 | |
| 60282 | |
| 60284 | |
| | 60286 |

COD

Ega Master es el fabricante mundial con mayor gama de desatascadores que permiten trabajar desde redes domésticas hasta grandes instalaciones.

Ega Master is the manufacturer in the world with the biggest range of pipe and drain cleaners which enables the user to work on small home pipes as well as on big facilities.

Ega Master est le fabricant avec le plus grande gamme au monde de déboucheurs, qui permettent le travail du réseau domestique aux grandes installations.

4 La amplia gama de desatascadores Ega Master comprende punteras desde 16mm hasta 30mm para cualquier trabajo.

The wide range of Ega Master pipe cleaners has different drill sizes from 16mm up to 30mm for any work.

La grande gamme de déboucheurs Ega Master comprend des embouts de 16mm à 30 mm pour tous les travaux.

1 Todos los desatascadores Ega Master tienen los elementos necesarios para un uso ergonómico y cómodo.

All the Ega Master pipe cleaners have the necessary elements to ensure an ergonomic and comfortable use.

Tous les déboucheurs Ega Master sont dotés d'éléments nécessaires à l'ergonomie et au confort d'utilisation.

2 El tubo protector permite un uso seguro sin ningún daño para el usuario profesional.

Protection tube enables professional users to have a safe use without any damage.

Le tube protecteur permet un usage sûr sans aucun risque de blessure pour l'utilisateur professionnel.

3 Se han diseñado pensando en todos los detalles, hasta los soportes plásticos para evitar dañar el suelo.

They have been designed taking into account all the details, even the plastic stands to avoid damaging the floor.

Ils ont été dessinés en pensant à tous les détails, jusqu'aux supports plastiques, pour éviter d'abîmer le sol.



Los distintos tipos de punteras se adaptan a cualquier tipo de trabajo de mantenimiento de redes.

The different type of drills are valid for any pipe or drain cleaning operation.

Les différents types d'embouts sont adaptés à tous types de travaux de maintenance de réseau.



Cada máquina incluye los equipos de seguridad necesarios.

Each machine includes all necessary safety equipment.

Chaque machine est vendue avec l'équipement de sécurité nécessaire.



Disponibles equipos a batería para trabajo cómodo e independiente del suministro eléctrico.

Models with battery are available for comfortable use.

Des équipements à batterie sont disponibles pour un travail aisé et non tributaire du réseau électrique.

DESATASCADORES / PIPE CLEANERS / DEBOUCHEURS / ROHRREINIGUNGSGERÄTE
 STURATUBI / ONTSTOPPINGSAPPARAAT / DESENTUPIDORES

DESATASCADOR DE TAMBOR / PIPE CLEANER / DEBOUCHEUR ELECTRIQUE / ROHRREINIGUNGSGERÄT / STURATUBI A TAMBORO / ONTSTOPPER / DESENTUPIDOR DE TAMBOR

| COD | L | Ø | W |
|-------|-----|-----|---|
| 69500 | 4,6 | 775 | 6 |



DESATASCADOR DE MUELLE / SPRING PIPE CLEANER / DEBOUCHEUR / ROHRREINIGUNGSGERÄT / NETTATUBI
 ONTSTOPPINGSAPPARAAT / DESENTUPIDOR DE MOLA

| COD | L | Ø | W |
|-------|----|------|----|
| 69505 | 3 | 350 | 12 |
| 69506 | 5 | 1400 | 20 |
| 69507 | 10 | 2500 | 12 |



| | Ø | CAP |
|-----------------------------|---|-------------|
| Drainmatic Handy 75 | 8mm (muelle / spring / ressort) | Ø20-Ø75mm |
| Drainmatic Handy 75 Auto | | |
| Drainmatic Portable 75 | | |
| Drainmatic Portable 75 Auto | | |
| Drainmatic 100 | 8mm - 16mm (muelle / spring / ressort) | Ø20-Ø100mm |
| Drainmatic MAX 100 | 16mm (muelle / spring / ressort) | Ø32-Ø100mm |
| Drainmatic MAX 110 | 12,5mm (muelle / spring / ressort) | Ø20-Ø110mm |
| Drainmatic MAX 150 | 8mm - 16mm - 22mm (muelle / spring / ressort) | Ø20-Ø150mm |
| Drainmatic MAX 200 | 30mm (muelle / spring / ressort) | Ø50-Ø200mm |
| Drainmatic MAX 600 | 8x22mm (varilla / rod / baguette) | Ø200-Ø600mm |

EGA Master S.A.
 ART IN INNOVATION



DESATASCADORES / PIPE CLEANERS / DEBOUCHEURS / ROHRREINIGUNGSGERÄTE
 STURATUBI / ONTSTOPPINGSAPPARAAT / DESENTUPIDORES

DRAINMATIC HANDY 75



| COD | V | W | rpm | CAP | Kg. |
|-------|------|------|----------|------------|------|
| 60290 | 230V | 600W | 0-450rpm | Ø 20-75 mm | 10,7 |
| 60291 | 110V | | | | |

* Incluye accesorios / Accessories included / Accessoires inclus

| Especificaciones técnicas / Technical specification / Détails techniques | |
|---|------------|
| Capacidad tubo / Pipe capacity / Capacité de tube | Ø 20-75 mm |
| Máxima longitud / Max. Length / Longueur max. | 7,6m |
| Ø muelle / Ø spring / Diamètre de ressort | Ø 8mm |
| Velocidad de giro / Turning speed / Vitesse de rotation | 0-550 rpm |
| Interruptor de cambio de sentido de giro / Turning way selector switch Bouton de changement de sens de rotation | ● |
| Agarre ergonómico / Ergonomic grip / Prise ergonomique | ● |
| Tambor de cable en 2 piezas metálicas resistentes al impacto y corrosión / 2 piece spring canister resistant to impact and corrosion / Tambour de câble en 2 pièces métalliques résis- tant au choc et à la corrosion | ● |
| Ligero y fácil de usar / Lightweight and easy-to-use / Léger et facile à utiliser | ● |
| Peso en uso / Working weigh / Poids en travail | 6 Kg |
| Potencia / Power / Puissance | 600 W |

ACCESORIOS INCLUIDOS / INCLUDED SPARE PARTS / ACCESSOIRES INCLUS / ERSATZTEILEN EINSCHLIEß LICH / ACCESSORI
 INCLUSI / INCLUSIEF WISSELSTUKKEN / ACESSÓRIOS INCLUÍDOS

| COD | LxWxH | Kg. |
|-------|----------------|-----|
| 64648 | 550x245x250 mm | 4 |



| COD | Ø x L | Kg. |
|-------|---------------|-----|
| 85114 | Ø 8mm x 7,6mm | 1,8 |



DRAINMATIC HANDY 75 AUTO



| COD | V | W | rpm | CAP | Kg |
|--------|------|------|----------|------------|------|
| 60292* | 230V | 600W | 0-450rpm | Ø 20-75 mm | 11,2 |
| 60293* | 110V | | | | |

* Incluye accesorios / *Accessories included* / *Accessoires inclus*

| Especificaciones técnicas / <i>Technical specification</i> / <i>Détails techniques</i> | |
|---|------------|
| Avance de muelle automático / <i>Automatic spring advance</i> / <i>Avance du ressort automatique</i> | ● |
| Velocidad de avance de muelle / <i>Spring advance speed</i> / <i>Vitesse d'avance du ressort</i> | 5m/min |
| Capacidad tubo / <i>pipe capacity</i> / <i>Capacité de tube</i> | Ø 20-75 mm |
| Máxima longitud / <i>Max. Length</i> / <i>Longueur max.</i> | 7,6m |
| Ø muelle / <i>Ø spring</i> / <i>Diamètre de ressort</i> | Ø 8mm |
| Velocidad de giro / <i>Turning speed</i> / <i>Vitesse de rotation</i> | 0-550 rpm |
| Interruptor de cambio de sentido de giro / <i>Turning way selector switch</i> <i>Bouton de changement de sens de rotation</i> | ● |
| Agarre ergonómico / <i>Ergonomic grip</i> / <i>Prise ergonomique</i> | ● |
| Tambor de cable en 2 piezas metálicas resistentes al impacto y corrosión / <i>2 piece spring canister resistant to impact and corrosion</i> / <i>Tambour de câble en 2 pièces métalliques résistant au choc et à la corrosion</i> | ● |
| Ligero y fácil de usar / <i>Lightweight and easy-to-use</i> / <i>Léger et facile à utiliser</i> | ● |
| Peso en uso / <i>Working weigh</i> / <i>Poids en travail</i> | 6 Kg |
| Potencia / <i>Power</i> / <i>Puissance</i> | 600 W |

ACCESORIOS INCLUIDOS / *INCLUDED SPARE PARTS* / *ACCESSOIRES INCLUS* / *ERSATZTEILEN EINSCHLIEß LICH* / *ACCESSORI INCLUSI* / *INCLUSIEF WISSELSTUKKEN* / *ACESSÓRIOS INCLUIDOS*

| COD | LxWxH | Kg |
|-------|----------------|----|
| 64648 | 550x245x250 mm | 4 |



| COD | Ø x L | Kg |
|-------|--------------|-----|
| 85114 | Ø 8mm x 7,6m | 1,8 |



| COD | Velocidad / Speed | Kg |
|-------|-------------------|-----|
| 83694 | 5m/min | 0,5 |



DRAINMATIC PORTABLE 75



| COD | V | W | rpm | CAP | Kg |
|-------|------|------|----------|------------|----|
| 60294 | 230V | 600W | 0-450rpm | Ø 20-75 mm | 11 |
| 60295 | 110V | | | | |

* Incluye accesorios / *Accessories included* / *Accessoires inclus*

| Especificaciones técnicas / <i>Technical specification</i> / <i>Détails techniques</i> | |
|--|-----------------|
| Capacidad tubo / <i>pipe capacity</i> / <i>Capacité de tube</i> | Ø 20-75 mm |
| Máxima longitud / <i>Max. Length</i> / <i>Longueur max.</i> | 6 m |
| Ø muelle / <i>Ø spring</i> / <i>Diamètre de ressort</i> | Ø 8mm |
| Velocidad de giro / <i>Turning speed</i> / <i>Vitesse de rotation</i> | 0-450 rpm |
| Interruptor de cambio de sentido de giro / <i>Turning way selector switch</i> <i>Bouton de changement de sens de rotation</i> | ● |
| Agarre ergonómico / <i>Ergonomic grip</i> / <i>Prise ergonomique</i> | ● |
| Tambor de cable en 2 piezas metálicas resistentes al impacto y corrosión / <i>2 piece spring canister resistant to impact and corrosion</i> <i>Tambour de câble en 2 pièces métalliques résistant au choc et à la corrosion</i> | ● |
| Ligero y fácil de usar / <i>Lightweight and easy-to-use</i> / <i>Léger et facile à utiliser</i> | ● |
| Peso en uso / <i>Working weigh</i> / <i>Poids en travail</i> | 5,3 Kg |
| Batería Ni-mh / <i>Battery Ni-mh</i> / <i>Batterie Ni-mh</i> | 14,4V - 2400mAh |
| Potencia / <i>Power</i> / <i>Puissance</i> | 600 W |

ACCESORIOS INCLUIDOS / INCLUDED SPARE PARTS / ACCESSOIRES INCLUS / ERSATZTEILEN EINSCHLIEß LICH / ACCESSORI INCLUSI / INCLUSIEF WISSELSTUKKEN / ACESSÓRIOS INCLUIDOS

| COD | LxWxH | Kg |
|-------|----------------|----|
| 64648 | 550x245x250 mm | 4 |



| COD | Ø x L | Kg |
|-------|-------------|-----|
| 85114 | Ø 8mm x 6mm | 1,4 |



| COD | V | Kg |
|-------|-------|-----|
| 83696 | 14,4V | 0,8 |



| COD | V | Kg |
|-------|------|-----|
| 64649 | 230V | 1,2 |
| 64650 | 110V | |



DRAINMATIC PORTABLE 75 AUTO



CE *G12

| COD | V | W | rpm | CAP | Kg |
|--------|------|------|----------|------------|------|
| 60296* | 230V | 600W | 0-450rpm | Ø 20-75 mm | 11,5 |
| 60297* | 110V | | | | |

* Incluye accesorios / *Accesorios included* / *Accessoires inclus*

| Especificaciones técnicas / <i>Technical specification</i> / <i>Détails techniques</i> | |
|---|-----------------|
| Avance de muelle automático / <i>Automatic spring advance</i> / <i>Avance du ressort automatique</i> | ● |
| Velocidad de avance de muelle / <i>Spring advance speed</i> / <i>Vitesse d'avance du ressort</i> | 5m/min |
| Capacidad tubo / <i>pipe capacity</i> / <i>Capacité de tube</i> | Ø 20-75 mm |
| Máxima longitud / <i>Max. Length</i> / <i>Longueur max.</i> | 6 m |
| Ø muelle / <i>Ø spring</i> / <i>Diamètre de ressort</i> | Ø 8mm |
| Velocidad de giro / <i>Turning speed</i> / <i>Vitesse de rotation</i> | 0-450 rpm |
| Interruptor de cambio de sentido de giro / <i>Turning way selector switch</i> <i>Bouton de changement de sens de rotation</i> | ● |
| Agarre ergonómico / <i>Ergonomic grip</i> / <i>Prise ergonomique</i> | ● |
| Tambor de cable en 2 piezas metálicas resistentes al impacto y corrosión / <i>2 piece spring canister resistant to impact and corrosion</i> / <i>Tambour de câble en 2 pièces métalliques résistant au choc et à la corrosion</i> | ● |
| Ligero y fácil de usar / <i>Lightweight and easy-to-use</i> / <i>Léger et facile à utiliser</i> | ● |
| Peso en uso / <i>Working weigh</i> / <i>Poids en travail</i> | 5,8 Kg |
| Batería Ni-mh / <i>Battery Ni-mh</i> / <i>Batterie Ni-mh</i> | 14,4V - 2400mAh |
| Potencia / <i>Power</i> / <i>Puissance</i> | 600 W |

ACCESORIOS INCLUIDOS / *INCLUDED SPARE PARTS* / *ACCESSOIRES INCLUS* / *ERSATZTEILEN EINSCHLIEß LICH* / *ACCESSORI INCLUSI* / *INCLUSIEF WISSELSTUKKEN* / *ACESSÓRIOS INCLUIDOS*

| COD | LxWxH | Kg |
|-------|----------------|-----|
| 64648 | 550x245x250 mm | 3,5 |

| COD | Ø x L | Kg |
|-------|-------------|-----|
| 85115 | Ø 8mm x 6mm | 1,4 |

| COD | Velocidad / Speed | Kg |
|-------|-------------------|-----|
| 83694 | 5m/min | 0,5 |

| COD | V | Kg |
|-------|-------|-----|
| 83696 | 14,4V | 0,8 |

| COD | V | Kg |
|-------|------|-----|
| 64649 | 230V | 1,2 |
| 64650 | 110V | |



DRAINMATIC 100



| COD | V | CAP | W | rpm | Kg |
|--------|------|-------------|-------|---------|----|
| 60040* | 230V | Ø 20-100 mm | 390 W | 400 rpm | 32 |
| 60041* | 110V | | | | |

* Incluye accesorios / *Accesorios included* / *Accessoires inclus*

| Especificaciones técnicas / <i>Technical specification</i> / <i>Détailles techniques</i> | |
|--|-------------|
| Capacidad tubo / <i>pipe capacity</i> / <i>Capacité de tube</i> | Ø 20-100 mm |
| Máxima longitud / <i>Max. Length</i> / <i>Longueur max.</i> | 30 m |
| Ø muelle / <i>Ø spring</i> / <i>Diamètre de ressort</i> | Ø 8 - 16 mm |
| Velocidad de giro / <i>Turning speed</i> / <i>Vitesse de rotation</i> | 400 rpm |
| Interruptor de cambio de sentido de giro / <i>Turning way selector switch</i> <i>Bouton de changement de sens de rotation</i> | ● |
| Agarre ergonómico / <i>Ergonomic grip</i> / <i>Prise ergonomique</i> | ● |
| Guantes incluidos / <i>Gloves included</i> / <i>Gants inclus</i> | ● |
| Maxima estabilidad / <i>Maximum estability</i> / <i>Stabilité maximale</i> | ● |
| Ligero y fácil de usar / <i>Lightweight and easy-to-use</i> / <i>Léger et facile à utiliser</i> | ● |
| Peso en uso / <i>Working weigh</i> / <i>Poids en travail</i> | 12 Kg |
| Potencia / <i>Power</i> / <i>Puissance</i> | 390 W |

ACCESORIOS INCLUIDOS / INCLUDED SPARE PARTS / ACCESSOIRES INCLUS / ERSATZTEILEN EINSCHLIEß LICH / ACCESSORI INCLUSI / INCLUSIEF WISSELSTUKKEN / ACESSÓRIOS INCLUIDOS

| COD | Ø | L | gr. | | |
|-------|-------|--------|------|------|------|
| 64240 | 16 mm | 135 mm | 70 | | |
| 64241 | | | 50 | | |
| 64242 | | 100 mm | 70 | | |
| 64249 | | 130 mm | 85 | | |
| 64243 | | 35 mm | 32 | | |
| 64244 | | 28 mm | 35 | | |
| 64245 | | 37 mm | 25 | | |
| 64246 | | 40 mm | | | |
| 64248 | | 8x2,5m | | 9745 | |
| 85103 | | | 2,5m | | 1200 |
| 85104 | 8mm | 4,5m | | 2350 | |
| 64624 | - | - | | 100 | |

DRAINMATIC MAX 100



| COD | V | CAP | W | rpm | Kg |
|--------|------|-------------|-------|---------|----|
| 60280* | 230V | Ø 32-100 mm | 390 W | 400 rpm | 22 |
| 60281* | 110V | | | | |

* Incluye accesorios / Accessories included / Accessoires inclus

| Especificaciones técnicas / Technical specification / Détails techniques | |
|--|-------------|
| Capacidad tubo / pipe capacity / Capacité de tube | Ø 32-100 mm |
| Máxima longitud / Max. Length / Longueur max. | 30 m |
| Ø muelle / Ø spring / Diamètre de ressort | Ø 16 mm |
| Velocidad de giro / Turning speed / Vitesse de rotation | 400 rpm |
| Interruptor de cambio de sentido de giro / Turning way selector switch Bouton de changement de sens de rotation | ● |
| Agarre ergonómico / Ergonomic grip / Prise ergonomique | ● |
| Guantes incluidos / Gloves included / Gants inclus | ● |
| Tubo de seguridad incluido / Safe tube included / Tube de sécurité inclus | ● |
| Maxima estabilidad / Maximum stability / Stabilité maximale | ● |
| Ligero y fácil de usar / Lightweight and easy-to-use / Léger et facile à utiliser | ● |
| Peso en uso / Working weigh / Poids en travail | 12 Kg |
| Potencia / Power / Puissance | 390 W |

ACCESORIOS INCLUIDOS / INCLUDED SPARE PARTS / ACCESSOIRES INCLUS / ERSATZTEILEN EINSCHLIEß LICH / ACCESSORI INCLUSI / INCLUSIEF WISSELSTUKKEN / ACESSÓRIOS INCLUIDOS

| COD | Ø | L | gr | | |
|-------|-------|---------|------|------|--|
| 64240 | 16 mm | 135 mm | 70 | | |
| 64241 | | | 50 | | |
| 64243 | | 35 mm | 32 | | |
| 64245 | | 37 mm | 25 | | |
| 64611 | | 6x2,5 m | 7700 | | |
| 85103 | | 2,5m | 1200 | | |
| 64623 | | 40 mm | 4m | 2300 | |
| 64624 | | - | - | 100 | |

*G12: GARANTIA 12 MESES / 12 MONTHS OF WARRANTY / 12 MOIS DE GARANTIE / 12 MONATEN GARANTIE / 12 MAANDEN GARANTIE / 12 MESI DI GARANZIA

NATO Commercial and Government Entity (NCAGE) Code / Código (NCAGE) OTAN: 8552B



DRAINMATIC MAX 150



| COD | V | CAP | W | rpm | Kg. |
|--------|------|-------------|------|---------|-----|
| 60282* | 230V | Ø 20-150 mm | 390W | 400 rpm | 42 |
| 60283* | 110V | | | | |

* Incluye accesorios / *Accessories included* / *Accessoires inclus*

| Especificaciones técnicas / <i>Technical specification</i> / <i>Détailles techniques</i> | |
|--|--------------|
| Capacidad tubo / <i>pipe capacity</i> / <i>Capacité de tube</i> | Ø 20-150 mm |
| Máxima longitud / <i>Max. Length</i> / <i>Longueur max.</i> | 30 m |
| Ø muelle / <i>Ø spring</i> / <i>Diamètre de ressort</i> | Ø 8-16-22 mm |
| Velocidad de giro / <i>Turning speed</i> / <i>Vitesse de rotation</i> | 400 rpm |
| Interruptor de cambio de sentido de giro / <i>Turning way selector switch</i> <i>Bouton de changement de sens de rotation</i> | ● |
| Agarre ergonómico / <i>Ergonomic grip</i> / <i>Prise ergonomique</i> | ● |
| Guantes incluidos / <i>Gloves included</i> / <i>Gants inclus</i> | ● |
| Tubo de seguridad incluido / <i>Safe tube included</i> / <i>Tube de sécurité inclus</i> | ● |
| Maxima estabilidad / <i>Maximum stability</i> / <i>Stabilité maximale</i> | ● |
| Ligero y fácil de usar / <i>Lightweight and easy-to-use</i> / <i>Léger et facile à utiliser</i> | ● |
| Peso en uso / <i>Working weigh</i> / <i>Poids en travail</i> | 16 Kg |
| Potencia / <i>Power</i> / <i>Puissance</i> | 390 W |

ACCESORIOS INCLUIDOS / INCLUDED SPARE PARTS / ACCESSOIRES INCLUS / ERSATZTEILEN EINSCHLIEß LICH / ACCESSORI INCLUSI / INCLUSIEF WISSELSTUKKEN / ACESSÓRIOS INCLUÍDOS

| COD | Ø | ← L → | gr. | |
|-------|-------|---------|-------|--|
| 64240 | 16 mm | 135 mm | 70 | |
| 64628 | 22 mm | 190 mm | 165 | |
| 64629 | 22 mm | 140 mm | 175 | |
| 64249 | 16 mm | 130 mm | 85 | |
| 64241 | 16 mm | 135 mm | 50 | |
| 64243 | 16 mm | 35 mm | 32 | |
| 64626 | 22 mm | 57 mm | 60 | |
| 64625 | 22 mm | 65 mm | 80 | |
| 64623 | 40 mm | 4 m | 2300 | |
| 64630 | 16 mm | 6x2,5 m | 7700 | |
| 85100 | 16 mm | 2,5m | 1200 | |
| 64631 | 22 mm | 3x5 m | 10000 | |
| 85101 | 22 mm | 5 m | 2000 | |
| 85104 | 8 mm | 4,5 | 2350 | |
| 64624 | - | - | 100 | |

DRAINMATIC MAX 200



CE *G12

| COD | V | CAP | W | rpm | Kg |
|--------|------|-------------|-------|---------|----|
| 60284* | 230V | Ø 50-200 mm | 1100W | 700 rpm | 78 |
| 60285* | 110V | | | | |

* Incluye accesorios / Accessories included / Accessoires inclus

Especificaciones técnicas / Technical specification / Détails techniques

| | |
|---|-------------|
| Capacidad tubo / pipe capacity / Capacité de tube | Ø 50-200 mm |
| Máxima longitud / Max. Length / Longueur max. | 50 m |
| Ø muelle / Ø spring / Diamètre de ressort | Ø 30 mm |
| Velocidad de giro / Turning speed / Vitesse de rotation | 700 rpm |
| Interruptor de cambio de sentido de giro / Turning way selector switch / Bouton de changement de sens de rotation | ● |
| Guantes incluidos / Gloves included / Gants inclus | ● |
| Tubo de seguridad incluido / Safe tube included / Tube de sécurité inclus | ● |
| Maxima estabilidad / Maximum stability / Stabilité maximale | ● |
| Fácil de transportar / Easy to transport / Facile à transporter | ● |
| Peso en uso / Working weigh / Poids en travail | 45 Kg |
| Potencia / Power / Puissance | 1100 W |

ACCESORIOS INCLUIDOS / INCLUDED SPARE PARTS / ACCESSOIRES INCLUS / ERSATZTEILEN EINSCHLIEß LICH / ACCESSORI INCLUSI / INCLUSIEF WISSELSTUKKEN / ACESSÓRIOS INCLUÍDOS

| COD | Ø | L | gr. | |
|-------|-------|--------|-------|------|
| 64632 | 30 mm | 80 mm | 150 | |
| 64634 | | 195 mm | 590 | |
| 64635 | | 75 mm | 280 | |
| 64636 | | 265 mm | 365 | |
| 64637 | | 205 mm | 385 | |
| 64638 | | 120 mm | 235 | |
| 64623 | | 40 mm | - | 1000 |
| 64633 | 30 mm | 4x5 m | 28000 | |
| 85102 | 30 mm | 5 m | 7000 | |
| 64624 | - | - | 100 | |



DRAINMATIC MAX 600



| COD | V | CAP | W | rpm | Kg. |
|--------|------|--------------|-------|-------------|-----|
| 60286* | 230V | Ø 200-600 mm | 1600W | 100-600 rpm | 140 |
| 60287* | 110V | | | | |

* Incluye accesorios / *Accessories included* / *Accessoires inclus*

| Especificaciones técnicas / <i>Technical specification</i> / <i>Détails techniques</i> | |
|---|--------------|
| Capacidad tubo / <i>pipe capacity</i> / <i>Capacité de tube</i> | Ø 200-600 mm |
| Máxima longitud / <i>Max. Length</i> / <i>Longueur max.</i> | 50 m |
| Velocidad de giro ajustable / <i>Adjustable turning speed</i> / <i>Vitesse de rotation réglable</i> | 100-600 rpm |
| Interruptor de cambio de sentido de giro / <i>Turning way selector switch</i> / <i>Bouton de changement de sens de rotation</i> | ● |
| Guantes incluidos / <i>Gloves included</i> / <i>Gants inclus</i> | ● |
| Sistema de varillas / <i>Rod system</i> / <i>Système de baguette</i> | ● |
| Maxima estabilidad / <i>Maximum stability</i> / <i>Stabilité maximale</i> | ● |
| Fácil de transportar / <i>Easy to transport</i> / <i>Facile à transporter</i> | ● |
| Peso en uso / <i>Working weigh</i> / <i>Poids en travail</i> | 117 Kg |
| Potencia / <i>Power</i> / <i>Puissance</i> | 1600 W |

ACCESORIOS INCLUIDOS / *INCLUDED SPARE PARTS* / *ACCESSOIRES INCLUS* / *ERSATZTEILEN EINSCHLIEß LICH* / *ACCESSORI INCLUSI* / *INCLUSIEF WISSELSTUKKEN* / *ACESSÓRIOS INCLUÍDOS*

| COD | Ø | ←L→ | gr. | |
|-------|-------|------------|----------|-------|
| 64639 | 22 mm | 250 mm | 410 | |
| 64640 | | | 330 | |
| 64641 | | | 320 | |
| 64642 | | 250 mm | 340 | |
| 64643 | | 300 mm | 2170 | |
| 64669 | | 8mm x 22mm | 30x1,5 m | 16500 |
| 64653 | 1,5 m | | 2200 | |
| 64624 | - | - | 100 | |

DRAINMATIC MAX 110



| COD | V | CAP | W | rpm | Kg |
|--------|------|-------------|------|--------|----|
| 60288* | 230V | Ø 20-110 mm | 370W | 260rpm | 31 |
| 60289* | 110V | | | | |

* Incluye accesorios / Accessories included / Accessoires inclus

Especificaciones técnicas / Technical specification / Détails techniques

| | |
|---|-------------|
| Avance de muelle automático / Automatic spring advance / Avance du ressort automatique | ● |
| Velocidad de avance de muelle / Spring advance speed / Vitesse d'avance du ressort | 6m/min |
| Capacidad tubo / pipe capacity / Capacité de tube | Ø 20-110 mm |
| Máxima longitud / Max. Length / Longueur max. | 22,5 m |
| Ø muelle / Ø spring / Diamètre de ressort | Ø 12,5 mm |
| Velocidad de giro ajustable / Adjustable turning speed / Vitesse de rotation réglable | 260 rpm |
| Interruptor de cambio de sentido de giro / Turning way selector switch / Bouton de changement de sens de rotation | ● |
| Guantes incluidos / Gloves included / Gants inclus | ● |
| Tubo de seguridad incluido / Safe tube included / Tube de sécurité inclus | ● |
| Maxima estabilidad / Maximum stability / Stabilité maximale | ● |
| Fácil de transportar / Easy to transport / Facile à transporter | ● |
| Peso en uso / Working weigh / Poids en travail | 28 Kg |
| Potencia / Power / Puissance | 370 W |

ACCESORIOS INCLUIDOS / INCLUDED SPARE PARTS / ACCESSOIRES INCLUS / ERSATZTEILEN EINSCHLIEß LICH / ACCESSORI INCLUSI / INCLUSIEF WISSELSTUKKEN / ACCESSÓRIOS INCLUIDOS

| COD | Ø | L | gr. | |
|-------|---------|--------|------|--|
| 64644 | 12,5 mm | 135 mm | 50 | |
| 64645 | | 100 mm | 70 | |
| 64646 | | 28 mm | 35 | |
| 64647 | | 37 mm | 25 | |
| 64683 | 40 mm | - | 2200 | |
| 64624 | - | - | 100 | |





MASTERVISION 1



CE *G12

NEW

| COD | V | CAP |  |  |
|-------|------|------------|---|---|
| 60298 | 230V | Ø26-Ø200mm | 1 | 7 |
| 60299 | 110V | | | |

Especificaciones técnicas / Technical specification / Détails techniques

| | |
|--|---|
| Cámara INOX / INOX camera / Boitier INOX | Ø26mm |
| Longitud total cable / Cable total length / Longueur totale de câble | 30m |
| Barra empuje flexible / Flexible push rod / Barre de pulsion flexible | 30m |
| Inspección de tubos / Pipe inspection / Inspection de tubes | Ø40-Ø200mm |
| Monitor reclinable con 2m cable / Tilttable monitor with 2m cable / écran rabattable avec 2 m. de câble | 960x234 Pixel 5,6" |
| Monitor / Monitor / Moniteur | TFT color |
| Baterías / Batteries / batterie | 2 pcs: 12V Ni-Cd 1,2Ah |
| Duración batería / Battery operation time / Durée de fonction de batterie | 1,5h / bat |
| Cámara estanca / Waterproof camera / Boitier étanche | IP 68 - 3 bar / 30m |
| Salida de video integrada para grabación RCA / Video output by RCA socket for recording Sortie de video intégrée par imprimante RCA |  |
| Maleta / Case / Malette | 51 x 43 x 17 cm |
| Sensibilidad cámara / Required minimum illumination / Sensibilité de la caméra | 0,5 Lux |
| Sensor luminosidad / Illumination sensor / Senseur de luminosité | 1/3" COLOR CCD |
| Control automático de luminosidad / Automatic illumination control / Contrôle automatique de luminosité | AGC |
| Campo visual / Field of view / Champ visuel | 120° FOV |
| Fuente de luz blanca / White light source / Source de lumière blanche | 12 LED |
| Objetivo camera / Camera lens / Objectif de caméra | f=2,5mm / F=2,0 |
| Temperatura trabajo / Working temperature / Température de travail | -10°C - 50°C |
| Guía centradora Ø70-Ø150mm (no incluida) / Ø70-150mm centre guide (optional) Guide centreur Ø70-Ø150mm (en option) | 60318 |
| 6 cepillos de recambio para guía centradora (no incluidos) / 6 spare brushes for centre guide (optional) 6 brosses de rechange pour le guide centreur (en option) | 60319 |
| Protector de camara (no incluido) / camara protection (optional) / Protection de camera (en option) | 60337 |
| Localizador de cámara por radiofrecuencia (no incluido) / Radio-frequency camera locator (optional) Localisateur de caméra (en option) | 60336 |
| Espejo de visión lateral (no incluido) / Side view mirror (optional) / Miroù de vision latérale (en option) | 60339 |



MASTERVISION 2



| COD | V | CAP | | Kg |
|--|----------|------------|---|------------------------|
| 60279 | 110-230V | Ø70-Ø600mm | 1 | 7,5 |
| Especificaciones técnicas / Technical specification / Détails techniques | | | | |
| Cámara INOX / INOX camera / Boitier INOX | | | | Ø51mm |
| Longitud total cable / Cable total length / Longueur totale de câble | | | | 20m |
| Barra empuje flexible / Flexible push rod / Barre de pulsion flexible | | | | 20m |
| Contador de metros integrado / Integrated meter counter / Compteur de mètres intégré | | | | ● |
| Inspección de tubos / Pipe inspection / Inspection de tubes | | | | Ø70-Ø600mm |
| Grabación de vídeo / Video recording / imprimation de vidéo | | | | ● |
| Realización de fotos / Pictures capturing / Réalisation de photos | | | | ● |
| Tarjeta de almacenamiento incluida / Included storage card / Carte mémoire incluse | | | | 1GB CF |
| Lector de tarjetas / Card reader / Lecteur de cartes | | | | USB |
| Monitor reclinable con 2m cable / Tilttable monitor with 2m cable / écran rabattable avec 2 m. de câble | | | | 768x512 PAL Pixel 6,4" |
| Monitor / Monitor / Moniteur | | | | TFT color |
| Batería integrada / Integrated battery / Batterie incluse | | | | ● |
| Batería / Battery / Batterie | | | | 7,2V Ni-MH |
| Duración batería / Battery operation time / Durée de fonction de batterie | | | | 2h / bat |
| Tensión entrada / Input voltage / Voltage d'alimentation | | | | 100-240V |
| Cámara estanca / Splashproof camera / Boitier étanche | | | | IP 64 - 3 bar / 30m |
| Salida de video integrada para grabación FBAS / Video output FBAS socket for recording Sortie de video intégrée par imprimante FBAS | | | | ● |
| Conexión a trípode del monitor / Monitor connection to tripod / Connection tripolaire du moniteur | | | | S |
| Maleta aluminio / Aluminium case / Malette aluminio | | | | ● |
| Sensibilidad cámara / Required minimum illumination / Sensibilité de la caméra | | | | 0,4 Lux |
| Sensor luminosidad / Illumination sensor / Senseur de luminosité | | | | COLOR CCD |
| Rotación cámara / camera head rotation / Rotation camera | | | | 360° |
| Basculación cámara / camera head swivelling / Basculement caméra | | | | 180° |
| Fuente de luz blanca / White light source / Source de lumière blanche | | | | 6 LED + 4 filaments |
| Objetivo camera / Camera lens / Objectif de caméra | | | | f=2,0mm / F=2,0 |
| Temperatura trabajo / Working temperature / Température de travail | | | | 0°C - 40°C |
| Protector de camara / camara protection / Protection de camera | | | | 60317 |
| Cámara extra mini (no incluida) / extra camera mini (optional) / Caméra extra mini (en option) | | | | 60338 |
| Localizador de cámara por radiofrecuencia (no incluido) / Radio-frequency camera locator (optional) Localisateur de caméra (en option) | | | | 60336 |
| Set de guiado Ø150 mm (no incluido) / Ø150 mm guidance set (optional) Set de guidance Ø150 mm (en option) | | | | 60335 |
| 6 cepillos de recambio para guía centradora (no incluidos) / 6 spare brushes for centre guide (optional) 6 brosses de rechange pour le guide centreur (en option) | | | | 60319 |



MASTERVISION MINI



CE *G12

NEW

| COD | L(mm) | Ø (mm) | GT |
|-------|-------|--------|-----|
| 65790 | 1 | 7 | 280 |

Especificaciones técnicas / Technical specification / Détails techniques

| | |
|--|-----------------|
| Longitud de inspección / Inspection length / Longueur d'inspection | 1m |
| Ø fibra óptica / Fibre optics Ø / Ø fibre optique | 7mm |
| Pixels en imagen / Image pixels / Pixels en image | 7200 |
| Campo de visión / Field of view / Champ de vision | 45° |
| Espejo visión 90° / 90° view mirror / Miroir à 90° | ● |
| Estuche aluminio / Aluminium case / Etui en aluminium | ● |
| Pilas / Batteries / Piles | 3xAA LR6 (1,5V) |
| Iluminación / Lighting / illumination | 2 LED |
| Fuerte intensidad luminosa / Strong light intensity / Forte intensité lumineuse | ● |
| Vida del LED / LED long life / Duré de vie du LED | 100.000h |
| Resistente al agua, aceite, gasoil, ácidos débiles y álcali / Resistant to water, oil, diesel, weak acid and alkali / Résistants à l'eau, à l'huile, aux acides légers et aux alcaloïdes | ● |
| Temperatura de trabajo / Work temperature / Température de travail | -10°C - 80°C |
| Dimensiones estuche / Case dimensions / Dimensions de l'étui | 310x240x70mm |
| Resistencia a campos electromagnéticos / Electromagnetic fields resistant / Résistant aux champs électromagnétiques | ● |





LA NUEVA MAQUINA "COMBI" PARA ROSCAR Y RANURAR TODO EN UNO
THE NEW "COMBI" MACHINE FOR THREADING AND ROLL-GROOVING ALL-IN-ONE
LA NOUVELLE MACHINE "COMBI" POUR FILETER ET RAINURER

- 1** Ranuradora hidráulica hasta 12", para ranurados de gran calidad en tubos de acero, cobre e inoxidable.
 Hydraulic roll groover up to 12", for getting high quality grooves in steel, copper and stainless steel pipes.
 Rainureuse hydraulique jusqu'à 12", pour un rainurage de grande qualité des tubes acier, cuivre et inox.
- 2** Especialmente diseñada para trabajos a domicilio por su formato compacto, robusto y fácil de transportar.
 This machine is specially designed for job-site work due to its compact, strong and easy to transport format.
 Spécialement conçue pour des travaux sur chantier, grâce à sa forme compacte, robuste et facile à transporter.
- 3** Disponible en 2 formatos, ranuradora o roscadora, ofrece la posibilidad de convertirla de una en otra con la simple adquisición del accesorio complementario, con lo que se dispondrá de ranuradora y roscadora en una sola máquina.
 Available in 2 formats, roll groover or threading machine, offers the possibility to transform one into the other just by acquiring the required accessory, having at your disposal threading and roll-grooving functions in only one machine.
 Disponible en deux versions, rainureuse ou filière, elle offre la possibilité de se convertir de l'une à l'autre, simplement par acquisition des accessoires complémentaires, ce qui vous permettra de posséder les deux en une.
- 4** El cambio de accesorios puede realizarse en pocos segundos, siendo así la operación de ranurado mucho más fácil.
 Any accessory change-out can be accomplished in few seconds, making grooving operation much easier.
 Les changements d'accessoires peuvent être réalisés en quelques secondes facilitant l'opération de rainurage.



RANUMATIC "COMBI"

Ranuradora hidráulica hasta 12", para ranurados de gran calidad en tubos de acero, cobre e inoxidable.
 Hydraulic roll groover up to 12", for getting high quality grooves in steel, copper and stainless steel pipes.
 Rainureuse hydraulique 12", pour un rainurage de grande qualité de tubes d'acier, de cuivre et d'inox.

ROSCAMATIC 3
"COMBI"

Máquina roscadora de tubos hasta 3" con motor de inducción, rosca tubo de manera eficiente y segura gracias a su innovador sistema de copia.
 This threading machine can thread pipes up to 3" in a safe and efficient way due to its innovative copy system.
 Filière jusqu'à 3" avec un moteur à induction, fait un filetage de qualité et sûr, grâce à son système innovateur de copie.



MAQUINAS DE PRENSADO RADIAL / RADIAL PRESS FITTING MACHINES MACHINES Á RACCORDS / RADIALPRESSE / MACCHINA PRESS FITTING RADIAL MAQUINAS DE PRENSAR RADIAÍŠ

PRESSMATIC PORTABLE CCA

La maquina de prensado radial Pressmatic Portable CCA es compacta, manejable, ligera y portátil. El sistema de portatenazas giratoria permite acceder fácilmente a los lugares de mas difícil acceso de forma comoda e incluso a una sola mano. La rapidez de esta maquina se ve implementada por el sistema rapido de portamordazas, que permite un cambio eficiente y seguro de mordazas, asi como por el sistema de retorno automatico, que elimina tiempos muertos en las operaciones de prensado.

Su bateria de 12V, 2.0 Ah le da una larga autonomia de uso en lugares sin red eléctrica, teniendo la posibilidad de ser empleado con conexión a la red para lugares con acceso de red (accesorio opcional).

Pressmatic CCA pressfitting machine is compact, handy, light and portable. The revolving press jaw carrying system enables jobs in difficult places, in a comfortable way even one handed. The press jaw carrying system as well as the automatic reverse system make it extremely quick and safe, saving time and making the job more efficient. The 12V, 2.0 Ah battery provides long autonomy in places without electricity. An optional accessory also provides an electric plug connection where electricity is available.

La machine á sertissage Radial Pressmatic Portable CCA est compacte, maniable, légère et portable. Le système de porte-machoires pivotant, permet d'accéder facilement dans des coins exigüs et d'une seule main. La vitesse de cette machine est complétée para un système rapide de porte-machoires qui permet d'éviter les temps morts durant les opérations de sertissage. Sa batterie de 12 Volts, 2.0 Ah lui confère une grande autonomie dans les sites sans réseau électrique et peut être connectée au réseau (Accessoire en option).

Consulte en las siguientes paginas que mordaza debe seleccionar dependiendo del sistema de accesorios de prensar que vaya a emplear.

Check the following pages to make the right choice of pressing jaws depending on the pres fitting system you may use.

Consultez dans les pages suivantes, la machoire á sélectionner suivant le système d'accessoires á utiliser.



CE *G12



| COD | V | CAP Ø | Kg | BAT. | | |
|-------|--------------|-------------|-----|------|---|---|
| 60196 | 230V 50-60Hz | 10-76 (108) | 4,5 | ● | ● | ● |
| 60197 | 110V 50-60Hz | | | | | |

ACCESORIOS / SPARE PARTS / RECHANGES / ERSATZTEILE / ACCESSORI / TOEBEHOREN / ACESSORIOS

| COD | V |
|-------|--|
| 85000 | Batería / Battery / Batterie 12V, 2.0 Ah |



| COD | V |
|-------|--|
| 85001 | Cargador rápido / Quick charger 230V, 50 - 60Hz, 50W |
| 85004 | Chargeur rapide 110V, 50 -60Hz, 50W |



| COD | V |
|-------|--|
| 85002 | Conexión / Connection / Connexion 230V |
| 85003 | 110V |



PRESSMATIC CCA

La maquina de prensado radial Pressmatic CCA es compacta, manejable y ligera. El sistema de portatenazas giratoria permite acceder fácilmente a los lugares de mas difícil acceso de forma comoda e incluso a una sola mano. La rapidez de esta maquina se ve implementada por el sistema rapido de portamordazas, que permite un cambio eficiente y seguro de mordazas, asi como por el sistema de retorno automatico, que elimina tiempos muertos en las operaciones de prensado.

Pressmatic CCA pressfitting machine is compact, handy and light. The revolving press jaw carrying system enables jobs in difficult places, in a comfortable way even one handed. The press jaw carrying system as well as the automatic reverse system make it extremely quick and safe, saving time and making the job more efficient.

La machine de sertissage Radial Pressmatic CCA est compacte, maniable et légère. Le système porte-machoires pivotant permet d'accéder aisément dans les coins exigüs de façon commode et d'une seule main. La rapidité de cette machine se voit confortée par un mécanisme rapide de porte-machoires, qui permet un changement efficient et sûr des machoires, ainsi que par le système de retour automatique qui élimine les temps morts durant les opérations de sertissage.



CE *G12

Consulte en las siguientes paginas que mordaza debe seleccionar dependiendo del sistema de accesorios de prensar que vaya a emplear.

Check the following pages to make the right choice of pressing jaws depending on the pres fitting system you may use.

Consultez dans les pages suivantes, la machoïre á sélectionner suivant le système d'accessoires á utiliser.



| COD | V | CAP Ø | Kg | W |  |
|-------|--------------|-------------|-----|------|---|
| 60194 | 230V 50-60Hz | 10-76 (108) | 4,8 | 450W | ● |
| 60195 | 110V 50-60Hz | | | | |

TENAZAS DE PRENSADO RADIAL / RADIAL PRESS FITTING PLIER / PINCES POUR RACCORDS /
PRESSZANGE / PINZA PER PRESS FITTING RADIAL / PERSTANG
TURQUESES DE PRENSAR RADIAÍS

El prensador manual Masterpress permite prensar de forma rápida, cómoda y eficaz tubos de hasta 26mm de diámetro. Su reducido peso y sus mangos tubulares desmontables proporcionan un transporte rápido y confortable, para el que se ofrece una cómoda bolsa que permite además incluir 3 tenazas. Utiliza las mismas tenazas de prensar que las máquinas Pressmatic (solo las indicadas con *, consultar pagina 140-142).

Masterpress hand pressfitting makes pressing tubes up to 26mm easy, quick and comfortable. Its light structure and removable handles provide convenient transportation. A handy bag is provided, which allows transporting 3 pressing tongues as well. Masterpress hand pressfitting uses the same pressing tongues as Pressmatic machines (only the ones marked with *, please refer to page 140-142).

La pince á sertir manuelle Marterpress permet de sertir rapidement, aisément et efficacement des tubes jusqu'à un diamètre de 26 mm. Son poids réduit et ses manches tubulaires démontables permettent un transport rapide et commode á l'aide d'une poche dans laquelle on peut aussi incorporer 3 machoires. La pince a les même machoires á sertir que les machines Pressmatic (uniquement celles indiquées avec *, consulter page 140-142).



COD



68450

655

2,84



MORDAZAS PARA PRENSAR RADIAL / RADIAL PRESS FITTING TONGUES / MACHOÏRES
POUR RACCORDS / RADIALPRESSZANGEN / MORSA PER PRESS FITTING RADIAL /
RADIOALPERSTANGEN / MANDÍBULAS PARA PRENSAR RADIAÍS

Las mordazas de prensar EGA Master están fabricadas en acero especial forjado, con un endurecimiento especial que le confiere la máxima seguridad de prensado. Los contornos están diseñados específicamente para cada sistema de accesorios, habiendo sido mecanizados en centros de mecanizado de alta precisión, presentando así tolerancias inferiores a los realizados por microfundición, ofreciendo la máxima fiabilidad de prensado con cualquier sistema de accesorios de prensar. Se utilizan con las máquinas de prensar Pressmatic así como por la tenaza de prensar Masterpress, siendo también empleables por máquinas de otros fabricantes.

EGA Master pressing jaws are manufactured in special forging steel, being specially hardened. These features provide them with maximum working safety. Pressing contours are specifically designed for each pressing fitting system. They have been machined with high precision CNC machines, having much lower tolerances than microfusion, granting in this way maximum pressing reliability with any press fitting system. They are used with Pressmatic pressfitting machines, Masterpress pressing plier. They can also be used in other manufacturers machines.

Les machoires á sertir Egamaster sont fabriquées dans un acier forgé spécial, avec une dureté qui lui confère une sécurité de sertissage maximum. Les contours sont conçus spécifiquement pour chaque système d'accessoires, étant usinés dans des ateliers de grande précision, donnant de cette façon des tolérances inférieures á celles acquises par microfusion, garantissant le maximum de fiabilité du sertissage avec tous les systèmes d'accessoires á sertir. Les machoires sont utilisées avec les machines á sertir Pressmatic, ainsi qu'avec la pince á sertir Matsterpress, pouvant être aussi utilisées avec les machines d'autres fabricants.



Consulte en las siguientes paginas que mordaza debe seleccionar dependiendo del sistema de accesorios de prensar que vaya a emplear.

Check the following pages to make the right choice of pressing jaws depending on the pres fitting system you may use.

Consultez dans les pages suivantes, la machoire á sélectionner suivant le système d'accessoires á utiliser.

| System | COD | Type | System | COD | Type | System | COD | Type |
|----------------------|-------|------------|--------------------|-------|------------|------------------|-------|------------|
| AHSELL | 68361 | M 12 | chronimo- | 68379 | SA 12 | DIWAflex systems | 68394 | TH 16* |
| A-press | 68363 | M 15 | SANHA-NiroSan- | 68380 | SA 14 | | 68397 | TH 20* |
| Elgalvaniserant | 68365 | M 18 | Presssystem | 68381 | SA 15 | | 68400 | TH 26* |
| | 68366 | M 22 | | 68382 | SA 16 | | 68401 | TH 32 |
| | 68367 | M 28 | | 68383 | SA 18 | | 68411 | U 40 |
| | 68368 | M 35 | | 68384 | SA 22 | | 68412 | U 50 |
| | 68369 | M 42 (4G) | | 68385 | SA 28 | egeda Comisa | 68394 | TH 16* |
| | 68370 | M 54 (4G) | | 68386 | SA 35 | | 68397 | TH 20* |
| AHSELL | 68421 | V 12 | | 68387 | SA 42 (4G) | | 68400 | TH 26* |
| A-press koppar | 68423 | V 15 | | 68388 | SA 54 (4G) | | 68401 | TH 32 |
| | 68425 | V 18 | | 68361 | M 12 | | 68402 | TH 40 |
| | 68426 | V 22 | | 68363 | M 15 | egeda Baronio | 68421 | V 12 |
| | 68427 | V 28 | | 68365 | M 18 | | 68423 | V 15 |
| | 68428 | V 35 | | 68366 | M 22 | | 68425 | V 18 |
| | 68429 | V 42 | | 68367 | M 28 | | 68426 | V 22 |
| | 68430 | V 54 | | 68368 | M 35 | | 68427 | V 28 |
| AHSELL | 68363 | M 15 | | 68369 | M 42 (4G) | | 68428 | V 35 |
| A-press rosfritt | 68365 | M 18 | | 68370 | M 54 (4G) | | 68429 | V 42 |
| | 68366 | M 22 | | 68421 | V 12 | | 68430 | V 54 |
| | 68367 | M 28 | | 68422 | V 14 | Elkhart XPRESS | 68442 | VUS 1/2" |
| | 68368 | M 35 | | 68423 | V 15 | | 68444 | VUS 3/4" |
| | 68369 | M 42 (4G) | | 68424 | V 16 | | 68441 | VUS 1" |
| | 68370 | M 54 (4G) | | 68425 | V 18 | | 68440 | VUS 1.1/4" |
| AIRBEL | 68361 | M 12 | | 68426 | V 22 | | 68439 | VUS 1.1/2" |
| SERTINOX | 68363 | M 15 | | 68427 | V 28 | | 68443 | VUS 2" |
| | 68365 | M 18 | | 68428 | V 35 | EMPUR | 68392 | TH 14* |
| | 68366 | M 22 | | 68429 | V 42 | PEXPRESS | 68394 | TH 16* |
| | 68367 | M 28 | | 68430 | V 54 | | 68395 | TH 17* |
| | 68368 | M 35 | | | | | 68397 | TH 20* |
| ANBO C-press | 68361 | M 12 | Climatek | 68329 | H 14* | | 68400 | TH 26* |
| | 68363 | M 15 | ClimaTherm | 68330 | H 16* | | 68401 | TH 32 |
| | 68365 | M 18 | | 68333 | H 20* | eurotherm | 68394 | TH 16* |
| | 68366 | M 22 | | 68335 | H 26* | Multistrato | 68397 | TH 20* |
| | 68367 | M 28 | | 68336 | H 32 | Euro2000 | 68400 | TH 26* |
| | 68368 | M 35 | | 68337 | H 40 (4G) | | 68401 | TH 32 |
| | 68369 | M 42 (4G) | ClouSet Press | 68394 | TH 16* | | 68401 | TH 32 |
| | 68370 | M 54 (4G) | | 68396 | TH 18* | EUROTUBI INOX | 68363 | M 15 |
| APE Raccordi | 68392 | TH 14* | | 68397 | TH 20* | PRESSFITTING | 68365 | M 18 |
| a pressare | 68394 | TH 16* | CO.E.S | 68405 | U 14* | SYSTEM | 68366 | M 22 |
| | 68396 | TH 18* | Coesklima | 68406 | U 16* | | 68367 | M 28 |
| | 68397 | TH 20* | | 68407 | U 18* | | 68368 | M 35 |
| | 68400 | TH 26* | | 68408 | U 20* | | 68369 | M 42 (4G) |
| | 68401 | TH 32 | | 68409 | U 25* | | 68370 | M 54 (4G) |
| Aquatis Xpress | 68361 | M 12 | | 68410 | U 32 | FAR Rubinetterie | 68392 | TH 14* |
| | 68362 | M 14 W | | 68411 | U 40 | PRESSFAR | 68394 | TH 16* |
| | 68422 | V 14 | | 68412 | U 50 | | 68396 | TH 18* |
| | 68363 | M 15 | | 68413 | U 63 (S) | | 68397 | TH 20* |
| | 68364 | M 16 W | | 68414 | U 75 (S) | | 68400 | TH 26* |
| | 68424 | V 16 | | | | | 68401 | TH 32 |
| | 68365 | M 18 | Comap | 68421 | V 12 | | 68402 | TH 40 |
| | 68366 | M 22 | Sudopress Cu | 68422 | V 14 | | 68402 | TH 40 |
| | 68367 | M 28 | | 68423 | V 15 | | 68329 | H 14* |
| | 68368 | M 35 | | 68424 | V 16 | | 68330 | H 16* |
| | 68369 | M 42 (4G) | | 68425 | V 18 | | 68332 | H 18* |
| | 68370 | M 54 (4G) | | 68426 | V 22 | | 68333 | H 20* |
| Armaturljonsson | 68363 | M 15 | | 68427 | V 28 | | 68335 | H 26* |
| BALLOFIX PRES | 68365 | M 18 | | 68428 | V 35 | | 68336 | H 32 |
| | 68366 | M 22 | | 68429 | V 42 | | 68337 | H 40 (4G) |
| | 68423 | V 15 | | 68430 | V 54 | | 68405 | U 14* |
| | 68425 | V 18 | | | | | 68406 | U 16* |
| | 68426 | V 22 | | | | | 68407 | U 18* |
| ASTM F 1807 | 68418 | US 3/8** | Comap | 68307 | CO 12* | | 68408 | U 20* |
| (Fittings with | 68416 | US 1/2** | Sudopress PEX | 68308 | CO 16* | | 68410 | U 32 |
| Copper Crimp Ring | 68417 | US 3/4** | (PER) | 68309 | CO 20* | | 68411 | U 40 |
| for PEX tubing) | 68415 | US 1** | Comap | 68310 | CO 25* | | 68412 | V 12 |
| | 68420 | US 1.1/4** | Multiskin Gas | 68394 | TH 16* | F.B.Q. BARONIO | 68421 | V 12 |
| BAMPI BALPED | 68392 | TH 14* | | 68397 | TH 20* | BQ press | 68423 | V 15 |
| BAMPI BALPEX | 68394 | TH 16* | | 68400 | TH 26* | | 68424 | V 16 |
| | 68396 | TH 18* | Comap | 68401 | TH 32 | | 68425 | V 18 |
| | 68397 | TH 20* | Sudopress Skin | 68392 | TH 14* | | 68426 | V 22 |
| | 68400 | TH 26* | | 68394 | TH 16* | | 68427 | V 28 |
| | 68401 | TH 32 | | 68396 | TH 18* | | 68428 | V 35 |
| BARBI MULTIPLEX | 68327 | H 11.5* | | 68397 | TH 20* | | 68429 | V 42 |
| (Industrial Blansol) | 68329 | H 14* | | 68400 | TH 26* | | 68430 | V 54 |
| | 68330 | H 16* | | 68401 | TH 32 | FIMISOL | 68329 | H 14* |
| | 68331 | H 17* | | 68402 | TH 40 | HAKAPRESS | 68330 | H 16* |
| | 68332 | H 18* | | 68403 | TH 50 (S) | | 68331 | H 17* |
| | 68333 | H 20* | | 68404 | TH 63 (S) | | 68332 | H 18* |
| | 68335 | H 26* | Comap | 68394 | TH 16* | | 68333 | H 20* |
| | 68336 | H 32 | Sudopress Skin Gas | 68396 | TH 18* | | 68335 | H 26* |
| | 68337 | H 40 (4G) | | 68397 | TH 20* | | 68336 | H 32 |
| | 68411 | U 40 | | 68400 | TH 26* | | 68337 | H 40 (4G) |
| BEGETUBE/IVAR | 68300 | B 14* | CosmoCONNECT | 68312 | F 16* | | 68411 | U 40 |
| | 68301 | B 16* | | 68314 | F 20* | Fränkische | 68312 | F 16* |
| | 68302 | B 18* | | 68315 | F 26* | alpex-duo | 68313 | F 18* |
| | 68303 | B 20* | | 68316 | F 32 | | 68314 | F 20* |
| | 68304 | B 26 | | 68406 | U 16* | | 68315 | F 26* |
| | 68305 | B 32 | (NW26) | 68408 | U 20* | | 68316 | F 32 |
| | 68317 | F 40 | | 68409 | U 25* | | 68317 | F 40 |
| | 68318 | F 50 | | 68410 | U 32 | | 68318 | F 50 |
| | 68319 | F 63 (S) | | 68394 | TH 16* | | 68319 | F 63 (S) |
| beulco armatur ab | 68361 | M 12 | | 68397 | TH 20* | Fränkische | 68312 | F 16* |
| VSH-press | 68363 | M 15 | | 68400 | TH 26* | alpex F50 PROFI | 68314 | F 20* |
| | 68365 | M 18 | | 68401 | TH 32 | | 68315 | F 26* |
| | 68366 | M 22 | Dalpex | 68392 | TH 14* | | 68316 | F 32 |
| | 68367 | M 28 | LaserMultiDalpex | 68394 | TH 16* | | 68316 | F 32 |
| | 68368 | M 35 | | 68396 | TH 18* | | 68406 | U 16* |
| | 68369 | M 42 (4G) | | 68397 | TH 20* | | 68408 | U 20* |
| | 68370 | M 54 (4G) | | 68400 | TH 26* | (NW26) | 68409 | U 25* |
| BROEN | 68363 | M 15 | | 68401 | TH 32 | | 68410 | U 32 |
| BALLOFIX PRESS | 68365 | M 18 | | 68402 | TH 40 | | 68394 | TH 16* |
| | 68366 | M 22 | | 68403 | TH 50 (S) | | 68397 | TH 20* |
| | 68423 | V 15 | Dalpex | 68394 | TH 16* | | 68400 | TH 26* |
| | 68425 | V 18 | LaserMultinox | 68397 | TH 20* | | 68401 | TH 32 |
| | 68426 | V 22 | DiaNorm | 68392 | TH 14* | FRIATHERM Uni | 68330 | H 16* |
| BUCCHI tech MP | 68394 | TH 16* | HKS SITEC Press | 68394 | TH 16* | | 68333 | H 20* |
| | 68396 | TH 18* | | 68396 | TH 18* | | 68335 | H 26* |
| | 68397 | TH 20* | | 68397 | TH 20* | | 68336 | H 32 |
| | 68400 | TH 26* | | 68400 | TH 26* | | 68337 | H 40 (4G) |
| | 68401 | TH 32 | | 68401 | TH 32 | | 68411 | U 40 |
| | | | | 68402 | TH 40 | | | |



| System | COD | Type | System | COD | Type | System | COD | Type | | | |
|--|--|------------------------------|-------------------------------------|--|-----------|------------------------------|--|-----------------------------------|-----------|--------|--------|
| gabo Systemtechnik | 68391 | TH 12* | GS Waermensysteme System V | 68423 | V 15 | IMI | 68361 | M 12 | | | |
| | 68392 | TH 14* | | 68425 | V 18 | | 68362 | M 14 W | | | |
| | 68393 | TH 15* | | 68426 | V 22 | | 68422 | V 14 | | | |
| | 68394 | TH 16* | | 68427 | V 28 | | 68363 | M 15 | | | |
| | 68395 | TH 17* | | 68428 | V 35 | | 68364 | M 16 W | | | |
| | 68396 | TH 18* | HAGE DOMINOX | 68363 | M 15 | | 68424 | V 16 | | | |
| | 68397 | TH 20* | | 68365 | M 18 | | 68365 | M 18 | | | |
| | 68398 | TH 25* | | 68366 | M 22 | | 68366 | M 22 | | | |
| | 68400 | TH 26* | | 68367 | M 28 | | 68367 | M 28 | | | |
| | 68401 | TH 32 | | 68368 | M 35 | | 68368 | M 35 | | | |
| | 68402 | TH 40 | HAGOS | 68369 | M 42 (4G) | | IPAI IPANA-Press | 68389 | TH 10* | | |
| | 68403 | TH 50 (S) | | 68370 | M 54 (4G) | | | 68390 | TH 11.6* | | |
| | 68404 | TH 63 (S) | | HAKA.GERODUR HAKAPRESS | 68394 | | | TH 16* | 68391 | TH 12* | |
| | GAROS | 68392 | | | TH 14* | | | 68327 | H 11.5* | 68392 | TH 14* |
| 68394 | | TH 16* | | | 68329 | H 14* | | 68393 | TH 15* | | |
| 68397 | | TH 20* | 68330 | | H 16* | 68394 | | TH 16* | | | |
| 68400 | | TH 26* | 68331 | | H 17* | 68395 | | TH 17* | | | |
| 68401 | | TH 32 | 68332 | H 18* | 68396 | TH 18* | | | | | |
| 68402 | | TH 40 | 68333 | H 20* | 68397 | TH 20* | | | | | |
| Geberit Mapress C-STAHLL, EDELSTAHL, EDELSTAHL Gas (15bis 35mm), KUPFER, KUPFER Gas (15 bis 35mm) | | 68361 | M 12 | 68335 | H 26* | 68398 | | TH 25* | | | |
| | | 68363 | M 15 | 68336 | H 32 | 68400 | | TH 26* | | | |
| | | 68365 | M 18 | 68337 | H 40 (4G) | 68401 | | TH 32 | | | |
| | | 68366 | M 22 | 68411 | U 40 | 68402 | | TH 40 | | | |
| | | 68367 | M 28 | HALLTORP RORDELAR HR press Cu | 68421 | V 12 | | 68403 | TH 50 (S) | | |
| | | 68368 | M 35 | | 68423 | V 15 | 68404 | TH 63 (S) | | | |
| | | 68369 | M 42 (4G) | | 68425 | V 18 | IPALPEX (Industrie du Plastique et Accessoires) | 68392 | TH 14* | | |
| | | 68370 | M 54 (4G) | | 68426 | V 22 | | 68394 | TH 16* | | |
| | Geberit Mepla | 68320 | G 16* | | 68427 | V 28 | | 68396 | TH 18* | | |
| | | 68321 | G 20* | 68428 | V 35 | 68397 | | TH 20* | | | |
| | | 68322 | G 26* | 68429 | V 42 | 68400 | | TH 26* | | | |
| | | 68323 | G 32 | 68430 | V 54 | 68401 | | TH 32 | | | |
| | | 68324 | G 40 | HALLTORP RORDELAR HR press 316 (Rostfritt), HR press FZ (Forzinkat) | 68361 | M 12 | | 68402 | TH 40 | | |
| | | 68325 | G 50 | | 68363 | M 15 | | 68403 | TH 50 (S) | | |
| 68326 | | G 63 (S) | 68365 | | M 18 | 68404 | | TH 63 (S) | | | |
| General Fittings General-Flex-Press 5900 | | 68394 | TH 16* | | 68366 | M 22 | | IVAR IVAR-press | 68300 | B 14* | |
| | | 68397 | TH 20* | | 68367 | M 28 | | | 68301 | B 16* | |
| | | 68400 | TH 26* | 68368 | M 35 | 68302 | | | B 18* | | |
| | | 68401 | TH 32 | 68369 | M 42 (4G) | 68303 | | | B 20* | | |
| | | 68402 | TH 40 | 68370 | M 54 (4G) | 68304 | | | B 26 | | |
| | | 68403 | TH 50 (S) | Harden 2000 Poly-Pex 2000 | 68392 | TH 14* | 68305 | | B 32 | | |
| | | 68404 | TH 63 (S) | | 68394 | TH 16* | 68317 | | F 40 | | |
| | 68330 | H 16* | 68397 | | TH 20* | 68318 | F 50 | | | | |
| | 68333 | H 20* | 68400 | | TH 26* | 68319 | F 63 (S) | | | | |
| | 68335 | H 26* | Harden 2000 Plastic Press | | 68392 | TH 14* | Jager aquapress H | | 68329 | H 14* | |
| | 68336 | H 32 | | 68394 | TH 16* | 68330 | | | H 16* | | |
| | 68406 | U 16* | | 68397 | TH 20* | 68331 | | | H 17* | | |
| | 68408 | U 20* | | 68399 | TH 20* | 68332 | | | H 18* | | |
| | General Fittings General-Press- Steel 2300, General-press- Inox 2000 | 68361 | | M 12 | 68400 | TH 26* | | | 68333 | H 20* | |
| 68363 | | M 15 | 68349 | HE 32 | 68335 | H 26* | | | | | |
| 68365 | | M 18 | Henco | 68392 | TH 14* | 68336 | | H 32 | | | |
| 68366 | | M 22 | | 68394 | TH 16* | 68337 | | H 40 (4G) | | | |
| 68367 | | M 28 | | 68396 | TH 18* | 68411 | | U 40 | | | |
| 68368 | | M 35 | | 68397 | TH 20* | Jaraflex- Presssystem | | 68392 | TH 14* | | |
| 68369 | | M 42 (4G) | | 68399 | TH 20* | | | 68394 | TH 16* | | |
| 68370 | | M 54 (4G) | 68400 | TH 26* | 68396 | | | TH 18* | | | |
| +GF+ PRESS FIT, +GF+ NiroSan | | 68379 | SA 12 | 68397 | TH 20* | | | 68397 | TH 20* | | |
| | | 68381 | SA 15 | 68349 | HE 32 | | | 68400 | TH 26* | | |
| | | 68383 | SA 18 | Herz Pipefix | 68392 | | TH 14* | 68401 | TH 32 | | |
| | | 68384 | SA 22 | | 68393 | | TH 15* | 68402 | TH 40 | | |
| | | 68385 | SA 28 | | 68394 | | TH 16* | JUPITER Heizsysteme | 68406 | U 16* | |
| | | 68386 | SA 35 | | 68395 | | TH 17* | | 68408 | U 20* | |
| | 68387 | SA 42 (4G) | 68396 | | TH 18* | | 68409 | | U 25* | | |
| | 68388 | SA 54 (4G) | 68397 | TH 20* | 68410 | | U 32 | | | | |
| | 68361 | M 12 | 68399 | TH 20* | 68411 | | U 40 | | | | |
| | 68363 | M 15 | 68400 | TH 26* | 68403 | | TH 50 (S) | | | | |
| | 68365 | M 18 | 68404 | TH 63 (S) | 68404 | | TH 63 (S) | | | | |
| | 68366 | M 22 | HIDROTEC KLIMATEC | 68406 | U 16* | KAN-them | 68406 | | U 16* | | |
| | 68367 | M 28 | | 68407 | U 18* | | 68408 | | U 20* | | |
| | 68368 | M 35 | | 68408 | U 20* | | 68306 | | C 26 | | |
| 68369 | M 42 (4G) | 68409 | | U 25* | 68410 | | U 32 | | | | |
| 68370 | M 54 (4G) | 68410 | | U 32 | 68411 | | U 40 | | | | |
| 68421 | V 12 | HITEC Sistema Multistrato | 68392 | TH 14* | 68412 | | U 50 | | | | |
| 68423 | V 15 | | 68394 | TH 16* | 68413 | | U 63 (S) | | | | |
| 68425 | V 18 | | 68396 | TH 18* | 68414 | | U 75 (S) | | | | |
| 68426 | V 22 | | 68397 | TH 20* | Kisan | | 68357 | KI 16* | | | |
| 68427 | V 28 | | 68400 | TH 26* | | | 68358 | KI 20* | | | |
| 68428 | V 35 | 68401 | TH 32 | 68359 | | | KI 25* | | | | |
| 68429 | V 42 | hs SYSTEM Heizung | 68365 | M 18 | | | KOHLER inoxPRES | 68363 | M 15 | | |
| 68430 | V 54 | | hs SYSTEM Sanitar | 68330 | | | | H 16* | 68365 | M 18 | |
| Giacomini, Giacoflex, Giacotherm | 68392 | | | TH 14* | | | | 68332 | H 18* | 68366 | M 22 |
| | 68394 | | | TH 16* | | 68333 | | H 20* | 68367 | M 28 | |
| | 68396 | | | TH 18* | | 68335 | | H 26* | 68368 | M 35 | |
| | 68397 | TH 20* | | 68336 | | H 32 | | 68369 | M 42 (4G) | | |
| | 68400 | TH 26* | 68337 | H 40 (4G) | | 68370 | | M 54 (4G) | | | |
| | 68401 | TH 32 | IBP>B<press, IBP>B<press Gas | 68421 | | V 12 | | Lagerstedt & Krantz LK B-press | 68421 | V 12 | |
| | Giacomo Cimberio Cimpress | 68363 | | M 15 | | 68422 | | | V 14 | 68423 | V 15 |
| | | 68365 | | M 18 | | 68423 | | | V 15 | 68425 | V 18 |
| | | 68366 | | M 22 | | 68424 | | | V 16 | 68426 | V 22 |
| | | 68367 | | M 28 | 68425 | V 18 | | | 68427 | V 28 | |
| | | 68368 | M 35 | 68426 | V 22 | 68428 | | | V 35 | | |
| | | 68423 | V 15 | 68427 | V 28 | 68429 | | | V 42 | | |
| | | 68425 | V 18 | 68428 | V 35 | 68430 | V 54 | | | | |
| | | 68426 | V 22 | 68429 | V 42 | GS Wärmesysteme System TH | 68392 | | TH 14* | | |
| 68427 | | V 28 | 68430 | V 54 | 68394 | | TH 16* | | | | |
| 68428 | | V 35 | IDROSISTEMI TA-PRESS | 68394 | TH 16* | | 68396 | | TH 18* | | |
| 68429 | | V 42 | | 68397 | TH 20* | | 68397 | | TH 20* | | |
| 68430 | | V 54 | | 68399 | TH 20* | | 68400 | | TH 26* | | |
| GS Wärmesysteme System TH | | 68392 | | TH 14* | 68400 | | TH 26* | | 68401 | TH 32 | |
| | | 68394 | | TH 16* | 68401 | | TH 32 | 68402 | TH 40 | | |
| | 68396 | TH 18* | Lagerstedt & Krantz LK Universal | 68392 | TH 14* | | 68394 | TH 16* | | | |
| | 68397 | TH 20* | | 68397 | TH 20* | | 68399 | TH 25 LK* | | | |
| | 68400 | TH 26* | | 68399 | TH 25 LK* | | LVAGRUND LAVA-PRESS | 68392 | TH 14* | | |
| | 68401 | TH 32 | | 68400 | TH 26* | | | 68394 | TH 16* | | |
| | 68402 | TH 40 | | 68401 | TH 32 | | | 68397 | TH 20* | | |
| | 68403 | TH 50 (S) | 68402 | TH 40 | 68400 | | | TH 26* | | | |
| | 68404 | TH 63 (S) | | | 68401 | | | TH 32 | | | |
| | | | | | 68402 | TH 40 | | | | | |

| System | COD | Type |
|----------------------------------|----------|-----------|
| Mair Heiztechnik Gomafix M | 68327 | H 11.5* |
| | 68329 | H 14* |
| | 68330 | H 16* |
| | 68333 | H 20* |
| Mair Heiztechnik Gomafix CU/E | 68361 | M 12 |
| | 68363 | M 15 |
| | 68365 | M 18 |
| | 68366 | M 22 |
| Mair Heiztechnik M-Press | 68327 | H 11.5* |
| | 68329 | H 14* |
| | 68330 | H 16* |
| | 68333 | H 20* |
| | 68335 | H 26* |
| | 68336 | H 32 |
| | 68337 | H 40 (4G) |
| Mapress | ver/see | Geberit |
| Mark KG | 68394 | TH 16* |
| Polymark | 68397 | TH 20* |
| | 68400 | TH 26* |
| | 68401 | TH 32 |
| | 68392 | TH 14* |
| Ma.s.ter System PRESSMASTER | 68394 | TH 16* |
| | 68396 | TH 18* |
| | 68397 | TH 20* |
| | 68400 | TH 26* |
| | 68401 | TH 32 |
| | 68402 | TH 40 |
| | 68329 | H 14* |
| | 68330 | H 16* |
| | 68332 | H 18* |
| | 68333 | H 20* |
| | 68335 | H 26* |
| | 68336 | H 32 |
| | 68337 | H 40 (4G) |
| | 68405 | U 14* |
| | 68406 | U 16* |
| 68408 | U 20* | |
| 68409 | U 25* | |
| 68410 | U 32 | |
| 68411 | U 40 | |
| MAXITUB MAXIPRESS | 68374 | RF 12* |
| | 68375 | RF 16* |
| | 68376 | RF 20* |
| | 68377 | RF 25* |
| MEGARO HAKAPRESS | 68327 | H 11.5* |
| | 68329 | H 14* |
| | 68330 | H 16* |
| | 68331 | H 17* |
| | 68332 | H 18* |
| | 68333 | H 20* |
| | 68335 | H 26* |
| | 68336 | H 32 |
| | 68337 | H 40 (4G) |
| | 68411 | U 40 |
| MEGARO MEGAPRESS | 68301 | B 16* |
| | 68303 | B 20* |
| | 68304 | B 26 |
| | 68305 | B 32 |
| | 68317 | F 40 |
| | 68318 | F 50 |
| | 68319 | F 63 (S) |
| MULTITHETRM- PRESSSYSTEM | 68394 | TH 16* |
| | 68396 | TH 18* |
| | 68397 | TH 20* |
| | 68400 | TH 26* |
| | 68401 | TH 32 |
| multitubo systems | 68406 | U 16* |
| | 68408 | U 20* |
| | 68409 | U 25* |
| | 68410 | U 32 |
| | 68411 | U 40 |
| | 68412 | U 50 |
| | 68413 | U 63 (S) |
| 68414 | U 75 (S) | |
| NEUTHERM MEKUPRESS-HT | 68330 | H 16* |
| | 68333 | H 20* |
| | 68335 | H 26* |
| | 68336 | H 32 |
| | 68337 | H 40 (4G) |
| | 68411 | U 40 |
| Nicoll MULTIPROJECT | 68394 | TH 16* |
| | 68397 | TH 20* |
| | 68400 | TH 26* |
| | 68401 | TH 32 |
| | 68402 | TH 40 |
| Niklaus Nico-Press | 68329 | H 14* |
| | 68330 | H 16* |
| | 68331 | H 17* |
| | 68332 | H 18* |
| | 68333 | H 20* |
| | 68335 | H 26* |
| | 68336 | H 32 |
| | 68337 | H 40 (4G) |
| | 68411 | U 40 |
| N.T.M. winny-al | 68392 | TH 14* |
| | 68394 | TH 16* |
| | 68396 | TH 18* |
| | 68397 | TH 20* |
| | 68400 | TH 26* |
| | 68401 | TH 32 |
| | 68402 | TH 40 |

| System | COD | Type | |
|---|---|-------------|--------|
| Nupi MultiNupi | 68405 | U 14* | |
| | 68406 | U 16* | |
| | 68407 | U 18* | |
| | 68408 | U 20* | |
| | 68306 | C 26* | |
| | 68410 | U 32 | |
| | 68411 | U 40 | |
| | 68412 | U 50 | |
| | 68413 | U 63 (S) | |
| | Nussbaum Cupress, Cupress G, Optipress | 68421 | V 12 |
| | | 68423 | V 15 |
| | | 68425 | V 18 |
| | | 68426 | V 22 |
| 68427 | | V 28 | |
| 68428 | | V 35 | |
| 68429 | | V 42 | |
| 68430 | | V 54 | |
| Nussbaum Optiflex plus | 68435 | VP 16* | |
| | 68436 | VP 20* | |
| | 68437 | VP 25* | |
| | 68438 | VP 32 | |
| O.M.T. Heizungssystem | 68330 | H 16* | |
| | 68332 | H 18* | |
| | 68333 | H 20* | |
| | 68335 | H 26* | |
| | 68336 | H 32 | |
| Oventrop Cofit P | 68341 | H 16 A* | |
| | 68344 | H 20 A* | |
| | 68346 | H 26 A* | |
| | 68347 | H 32 A | |
| | 68348 | H 40 A (4G) | |
| Pavitherm MULTISTABIL | 68392 | TH 14* | |
| | 68394 | TH 16* | |
| | 68396 | TH 18* | |
| | 68397 | TH 20* | |
| | 68400 | TH 26* | |
| | 68401 | TH 32 | |
| PIPELIFE RADOPRESS | 68394 | TH 16* | |
| | 68396 | TH 18* | |
| | 68397 | TH 20* | |
| | 68400 | TH 26* | |
| | 68401 | TH 32 | |
| PB TUB SAPRESS | 68374 | RF 12* | |
| | 68375 | RF 16* | |
| | 68376 | RF 20* | |
| | 68377 | RF 25* | |
| | 68402 | TH 40 | |
| POLYSAN Handelges m.b.H & Co KG (Krems-Osterreich) POLYSAN- Press-System | 68392 | TH 14* | |
| | 68394 | TH 16* | |
| | 68395 | TH 17* | |
| | 68396 | TH 18* | |
| | 68397 | TH 20* | |
| | 68400 | TH 26* | |
| | 68401 | TH 32 | |
| | 68402 | TH 40 | |
| | 68403 | TH 50 (S) | |
| | 68404 | TH 63 (S) | |
| POLYSAN S.A. (Madrid-Espana) Sistema Rainbow | 68406 | U 16* | |
| | 68407 | U 18* | |
| | 68408 | U 20* | |
| | 68409 | U 25* | |
| | 68410 | U 32 | |
| | 68411 | U 40 | |
| | 68412 | U 50 | |
| | 68413 | U 63 (S) | |
| | 68338 | H 10.5 A* | |
| | 68339 | H 12 A* | |
| Polytherm Polyfix Polyfix-MT | 68340 | H 14 A* | |
| | 68341 | H 16 A* | |
| | 68344 | H 20 A* | |
| | 68346 | H 26 A* | |
| | 68347 | H 32 A | |
| | 68348 | H 40 A (4G) | |
| | 68340 | H 14 A* | |
| | 68341 | H 16 A* | |
| Prandelli MULTYRAMA | 68343 | H 18 A* | |
| | 68344 | H 20 A* | |
| | 68346 | H 26 A* | |
| | 68347 | H 32 A | |
| | 68411 | U 40 | |
| PRASKI BAVARIA-press | 68412 | U 50 | |
| | 68389 | TH 10* | |
| | 68394 | TH 16* | |
| | 68395 | TH 17* | |
| | 68397 | TH 20* | |
| | 68400 | TH 26* | |
| | 68401 | TH 32 | |
| | 68402 | TH 40 | |
| | PURMO HKS Sitec Press | 68392 | TH 14* |
| | | 68394 | TH 16* |
| 68395 | | TH 17* | |
| 68396 | | TH 18* | |
| 68397 | | TH 20* | |
| 68400 | | TH 26* | |
| 68401 | | TH 32 | |
| 68402 | | TH 40 | |
| remo | | 68329 | H 14* |
| | | 68330 | H 16* |
| | 68332 | H 18* | |
| | 68333 | H 20* | |
| | 68335 | H 26* | |
| | 68336 | H 32 | |
| | 68337 | H 40 (4G) | |

| System | COD | Type | |
|--|------------------------------------|-------------|--------|
| RIFENG U PRESS FITTING (F5) | 68406 | U 16* | |
| | 68407 | U 18* | |
| | 68408 | U 20* | |
| | 68409 | U 25* | |
| | 68410 | U 32 | |
| | 68411 | U 40 | |
| | 68412 | U 50 | |
| | 68413 | U 63 (S) | |
| | RIFENG TH PRESS FITTING (F9) | 68394 | TH 16* |
| | | 68397 | TH 20* |
| 68398 | | TH 25* | |
| 68400 | | TH 26* | |
| 68401 | | TH 32 | |
| RIQUIERA A SERTIR | 68328 | H 12* | |
| | 68330 | H 16* | |
| | 68333 | H 20* | |
| | 68334 | H 25* | |
| Rogapress | 68392 | TH 14* | |
| | 68394 | TH 16* | |
| | 68395 | TH 17* | |
| | 68396 | TH 18* | |
| | 68397 | TH 20* | |
| | 68400 | TH 26* | |
| | 68401 | TH 32 | |
| | 68301 | B 16* | |
| | 68302 | B 18* | |
| | 68303 | B 20* | |
| 68304 | B 26 | | |
| 68305 | B 32 | | |
| Roth | 68329 | H 14* | |
| | 68330 | H 16* | |
| | 68331 | H 17* | |
| | 68332 | H 18* | |
| | 68333 | H 20* | |
| | 68335 | H 26* | |
| | 68336 | H 32 | |
| | 68312 | F 16* | |
| | 68314 | F 20* | |
| | 68315 | F 26* | |
| 68316 | F 32 | | |
| Rubinetterie Bresciane Bonomi TURBO INOX, TURBO STEEL | 68317 | F 40 | |
| | 68318 | F 50 | |
| | 68319 | F 63 (S) | |
| | 68329 | H 14* | |
| | 68330 | H 16* | |
| Rubinetterie Bresciane Bonomi TURBO PRESS | 68331 | H 17* | |
| | 68332 | H 18* | |
| | 68333 | H 20* | |
| | 68335 | HR 14 A* | |
| | 68351 | HR 17 A* | |
| | 68352 | HR 20 A* | |
| | 68353 | HR 25 A* | |
| | 68354 | HR 32 A* | |
| | 68355 | HR 40 A (S) | |
| | 68356 | HR 50 A (S) | |
| SANHA- Pressfittings, SANHA-NiroSan- Presssystem, SANHA- Pressfittings Gas SANHA-NiroSan- Presssystem Gas | 68361 | M 12 | |
| | 68363 | M 15 | |
| | 68365 | M 18 | |
| | 68366 | M 22 | |
| | 68367 | M 28 | |
| | 68368 | M 35 | |
| | 68369 | M 42 (4G) | |
| | 68370 | M 54 (4G) | |
| | 68392 | TH 14* | |
| | 68394 | TH 16* | |
| | 68396 | TH 18* | |
| | 68397 | TH 20* | |
| | 68400 | TH 26* | |
| | 68401 | TH 32 | |
| | 68402 | TH 40 | |
| 68403 | TH 50 (S) | | |
| 68404 | TH 63 (S) | | |
| Schlosser EUROPRESS- SYSTEM | 68379 | SA 12 | |
| | 68380 | SA 14 | |
| | 68381 | SA 15 | |
| | 68382 | SA 16 | |
| | 68383 | SA 18 | |
| | 68384 | SA 22 | |
| | 68385 | SA 28 | |
| | 68386 | SA 35 | |
| | 68387 | SA 42 (4G) | |
| | 68388 | SA 54 (4G) | |
| | 68361 | M 12 | |
| | 68363 | M 15 | |
| | 68365 | M 18 | |
| | 68366 | M 22 | |
| | 68367 | M 28 | |
| 68368 | M 35 | | |
| 68369 | M 42 (4G) | | |
| 68370 | M 54 (4G) | | |
| 68421 | V 12 | | |
| 68422 | V 14 | | |
| 68423 | V 15 | | |
| 68424 | V 16 | | |
| 68425 | V 18 | | |
| 68426 | V 22 | | |
| 68427 | V 28 | | |
| 68428 | V 35 | | |
| 68429 | V 42 | | |
| 68430 | V 54 | | |
| Schlosser EUROPRESS- SYSTEM | 68394 | TH 16* | |
| | 68397 | TH 20* | |
| | 68400 | TH 26* | |
| | 68401 | TH 32 | |



| System | COD | Type | |
|---|--|-------------|--------|
| SCHUTZ EHT iOpress | 68392 | TH 14* | |
| | 68394 | TH 16* | |
| | 68397 | TH 20* | |
| | 68400 | TH 26* | |
| | 68401 | TH 32 | |
| Schwer AQUApress | 68402 | TH 40 | |
| | 68361 | M 12 | |
| | 68363 | M 15 | |
| | 68365 | M 18 | |
| | 68366 | M 22 | |
| | 68367 | M 28 | |
| Seppelfricke Distribuzione MTSD | 68368 | M 35 | |
| | 68369 | M 42 (4G) | |
| | 68370 | M 54 (4G) | |
| | 68423 | V 15 | |
| | 68426 | V 22 | |
| Seppelfricke Systemtechnik SST Delphi Press | 68427 | V 28 | |
| | 68428 | V 35 | |
| | 68429 | V 42 | |
| | 68392 | TH 14* | |
| | 68394 | TH 16* | |
| SIKO TYPRO TYROTHERM | 68397 | TH 20* | |
| | 68400 | TH 26* | |
| | 68401 | TH 32 | |
| | 68402 | TH 40 | |
| | Simplex VSH Dominox Edelstahl, VSH Press C-stahl, RYW Pressfittings Cu/Rg SiRoCon Cu/E | 68392 | TH 14* |
| 68394 | | TH 16* | |
| 68396 | | TH 18* | |
| 68397 | | TH 20* | |
| 68400 | | TH 26* | |
| 68361 | | M 12 | |
| 68363 | | M 15 | |
| 68365 | | M 18 | |
| 68366 | | M 22 | |
| 68367 | | M 28 | |
| Simplex SiRoCon Installationssystem H | 68368 | M 35 | |
| | 68369 | M 42 (4G) | |
| | 68370 | M 54 (4G) | |
| | 68327 | H 11.5* | |
| | 68330 | H 16* | |
| Simplex SiRoCon Installationssystem TH | 68333 | H 20* | |
| | 68335 | H 26* | |
| | 68336 | H 32 | |
| | 68394 | TH 16* | |
| | 68397 | TH 20* | |
| | 68400 | TH 26* | |
| | 68401 | TH 32 | |
| | SLOVARM PEX-THERM | 68406 | U 16* |
| | | 68408 | U 20* |
| | | 68335 | H 26* |
| 68410 | | U 32 | |
| 68330 | | H 16* | |
| 68333 | | H 20* | |
| SST-Rolltec Rosy | 68335 | H 26* | |
| | 68336 | H 32 | |
| | 68340 | H 14 A* | |
| | 68341 | H 16 A* | |
| | 68344 | H 20 A* | |
| | 68346 | H 26 A* | |
| SST-Rolltec Delphi-Press | 68347 | H 32 A | |
| | 68348 | H 40 A (4G) | |
| | 68392 | TH 14* | |
| | 68394 | TH 16* | |
| | 68396 | TH 18* | |
| | 68397 | TH 20* | |
| STS Systemtechnik | 68400 | TH 26* | |
| | 68401 | TH 32 | |
| | 68402 | TH 40 | |
| | 68392 | TH 14* | |
| | 68394 | TH 16* | |
| | 68396 | TH 18* | |
| System PREXTO | 68397 | TH 20* | |
| | 68399 | TH 26* | |
| | 68401 | TH 32 | |
| | 68402 | TH 40 | |
| | 68361 | M 12 | |
| | 68363 | M 15 | |
| System WELCO-Flex | 68365 | M 18 | |
| | 68366 | M 22 | |
| | 68340 | H 14 A* | |
| | 68341 | H 16 A* | |
| | 68342 | H 17 A* | |
| | 68344 | H 20 A* | |
| | 68346 | H 26 A* | |
| | 68347 | H 32 A | |
| TECHNO TRADE/ Frankische | 68348 | H 40 A (4G) | |
| | 68312 | F 16* | |
| | 68314 | F 20* | |
| | 68315 | F 26* | |
| | 68316 | F 32 | |
| | 68317 | F 40 | |
| THERMAGAS Espace Espresso | 68318 | F 50 | |
| | 68392 | TH 14* | |
| | 68394 | TH 16* | |
| | 68397 | TH 20* | |
| | 68400 | TH 26* | |
| | 68401 | TH 32 | |
| THERMOLUTZ acular, rapid | 68402 | TH 40 | |
| | 68329 | H 14* | |
| | 68330 | H 16* | |
| | 68331 | H 17* | |
| THERMOVAL THERMOSMART | 68392 | TH 14* | |
| | 68394 | TH 16* | |
| | 68396 | TH 18* | |
| | 68397 | TH 20* | |
| | 68400 | TH 26* | |
| | 68401 | TH 32 | |

| System | COD | Type | |
|--|---|------------|--------|
| TIEMME COBRAPRESS | 68392 | TH 14* | |
| | 68394 | TH 16* | |
| | 68397 | TH 20* | |
| | 68400 | TH 26* | |
| | 68401 | TH 32 | |
| | 68402 | TH 40 | |
| | 68403 | TH 50 (S) | |
| | 68404 | TH 63 (S) | |
| | TKM Fellingsbro TKMPRESS | 68329 | H 14* |
| | | 68330 | H 16* |
| 68331 | | H 17* | |
| 68332 | | H 18* | |
| 68333 | | H 20* | |
| 68335 | | H 26* | |
| 68336 | | H 32 | |
| 68337 | | H 40 (4G) | |
| Ulrich VARIOFLEX- HAKAPRESS | 68329 | H 14* | |
| | 68330 | H 16* | |
| Uponor Unipipe Uponor Airpipe | 68331 | H 17* | |
| | 68332 | H 18* | |
| | 68333 | H 20* | |
| | 68335 | H 26* | |
| | 68336 | H 32 | |
| | 68337 | H 40 (4G) | |
| | 68405 | U 14* | |
| | 68406 | U 16* | |
| | 68407 | U 18* | |
| | 68408 | U 20* | |
| Valsir PEXAL | 68409 | U 25* | |
| | 68410 | U 32 | |
| | 68411 | U 40 | |
| | 68412 | U 50 | |
| | 68413 | U 63 (S) | |
| | 68414 | U 75 (S) | |
| | 68329 | H 14* | |
| | 68330 | H 16* | |
| | 68333 | H 20* | |
| | 68335 | H 26* | |
| Variotherm System H | 68411 | U 40 | |
| | 68412 | U 50 | |
| Variotherm System TH | 68413 | U 63 (S) | |
| | 68414 | U 75 (S) | |
| Vescal Metalplast | 68327 | H 11.5* | |
| | 68330 | H 16* | |
| | 68390 | TH 11.6* | |
| | 68394 | TH 16* | |
| | 68406 | U 16* | |
| | 68407 | U 18* | |
| | 68408 | U 20* | |
| | 68409 | U 25* | |
| | 68410 | U 32 | |
| | 68411 | U 40 | |
| Viega- "Pexfit FOSTA" "PEXFIT PLUS" | 68412 | U 50 | |
| | 68413 | U 63 (S) | |
| | 68445 | VX 12* | |
| | 68446 | VX 16* | |
| | 68447 | VX 20* | |
| | 68442 | VUS 1/2" | |
| Viega-ProPress System (USA) | 68444 | VUS 3/4" | |
| | 68441 | VUS 1" | |
| | 68440 | VUS 1.1/4" | |
| | 68439 | VUS 1.1/2" | |
| | 68443 | VUS 2" | |
| | 68421 | V 12 | |
| Viega- "profitpress", "profitpress G" "profitpress THERM" "sanpress" "sanpress INOX" "sanpress INOX G" | 68431 | VG 14 | |
| | 68423 | V 15 | |
| | 68432 | VG 16 | |
| | 68425 | V 18 | |
| | 68426 | V 22 | |
| | 68427 | V 28 | |
| | 68428 | V 35 | |
| | 68429 | V 42 | |
| | 68430 | V 54 | |
| | Viega- "sanfix FOSTA" sanfix P" sanfix PLUS" "Viegatherm P" | 68434 | VP 14* |
| 68435 | | VP 16* | |
| 68436 | | VP 20* | |
| 68437 | | VP 25* | |
| 68438 | | VP 32 | |
| 68392 | | TH 14* | |
| Viessmann | 68394 | TH 16* | |
| | 68397 | TH 20* | |
| | 68400 | TH 26* | |
| | 68401 | TH 32 | |
| | 68402 | TH 40 | |
| | 68394 | TH 16* | |
| V.I. Trade ViTerm | 68396 | TH 18* | |
| | 68397 | TH 20* | |
| | 68400 | TH 26* | |
| | 68401 | TH 32 | |
| | 68392 | TH 14* | |
| | 68394 | TH 16* | |

| System | COD | Type | |
|--|--|-------------|---------|
| VSH Flow Control Staalpress, Cu-Press, Cu-Press Gas, (15 - 28mm) Inox-Press | 68363 | M 15 | |
| | 68365 | M 18 | |
| | 68366 | M 22 | |
| | 68367 | M 28 | |
| | 68368 | M 35 | |
| | 68369 | M 42 (4G) | |
| | 68370 | M 54 (4G) | |
| | VSH Flow Control POLYPRESS | 68394 | TH 16* |
| | | 68397 | TH 20* |
| | | 68400 | TH 26* |
| 68401 | | TH 32 | |
| 68402 | | TH 40 | |
| Watts MTR Art Press | 68403 | TH 50 (S) | |
| | 68394 | TH 16* | |
| | 68397 | TH 20* | |
| | 68400 | TH 26* | |
| | 68401 | TH 32 | |
| Wavin Future K 1, Wavin Future K 2, Wavin Tigris, Wavin Tigris Alupex Wavin Tigris Blue, Wavin Tigris PEX | 68406 | U 16* | |
| | 68407 | U 18* | |
| | 68408 | U 20* | |
| | 68409 | U 25* | |
| | 68410 | U 32 | |
| | 68411 | U 40 | |
| | 68412 | U 50 | |
| Wavin Tigris Press | 68448 | WA 12* | |
| | 68449 | WA 15* | |
| | 68407 | U 18* | |
| WeeConPress | 68363 | M 15 | |
| | 68365 | M 18 | |
| | 68366 | M 22 | |
| | 68367 | M 28 | |
| | 68368 | M 35 | |
| WEFA PLASTIC WEFATHERM- PRESS | 68369 | M 42 (4G) | |
| | 68370 | M 54 (4G) | |
| | 68330 | H 16* | |
| | 68333 | H 20* | |
| WEM | 68335 | H 26* | |
| | 68336 | H 32 | |
| | 68330 | H 16* | |
| Winkler | 68392 | TH 14* | |
| | 68394 | TH 16* | |
| | 68396 | TH 18* | |
| | 68397 | TH 20* | |
| | 68400 | TH 26* | |
| | 68401 | TH 32 | |
| | 68402 | TH 40 | |
| | 68403 | TH 50 (S) | |
| | Wirsbo-Velta biroduct P, Fusbodenheizung rapex multi | 68340 | H 14 A* |
| | | 68341 | H 16 A* |
| 68342 | | H 17 A* | |
| 68344 | | H 20 A* | |
| 68345 | | H 25 A* | |
| 68346 | | H 26 A* | |
| 68347 | | H 32 A | |
| 68348 | | H 40 A (4G) | |
| WKS | 68329 | H 14* | |
| | 68330 | H 16* | |
| | 68331 | H 17* | |
| | 68332 | H 18* | |
| | 68333 | H 20* | |
| | 68335 | H 26* | |
| | 68336 | H 32 | |
| | 68337 | H 40 (4G) | |
| | 68411 | U 40 | |
| | WOESTE "Yorkshire" RYW PRESS FITTINGS, RYW Gas PRESS FITTINGS, (15-35mm) VSH Dominox ZEWOTHERM | 68361 | M 12 |
| 68363 | | M 15 | |
| 68365 | | M 18 | |
| 68366 | | M 22 | |
| 68367 | | M 28 | |
| 68368 | | M 35 | |
| 68369 | | M 42 (4G) | |
| 68370 | | M 54 (4G) | |
| 68394 | | TH 16* | |
| 68395 | | TH 17* | |
| V.I. Trade ViTerm | 68397 | TH 20* | |
| | 68400 | TH 26* | |
| | 68401 | TH 32 | |
| | 68402 | TH 40 | |
| | 68403 | TH 50 (S) | |
| | 68404 | TH 63 (S) | |

MAQUINAS PARA TUBO / PIPING MACHINES / MACHINES POUR TUBE ROHRMASCHINEN / MACCHINE PER TUBI / PIJPMACHINES / MÁQUINAS PARA TUBO

MAQUINAS ROSCADORAS / PIPE THREADING MACHINES / FILIERES ELECTRIQUES
GEWINDESCHNEIDMASCHINEN / FILETTATRICI ELETTRICA / DRAADSNIJMACHINES

ROSCAMATIC - 1.1/2

| CAP. | W | V | R.P.M. |  |
|------------|------|----------------------|--------|---|
| 1/4-1.1/2" | 1250 | 230/50Hz 110/60Hz | 48 | 46 |







Motor Univ. / Moteur Univ. / Motore Univ.

Tubos / Pipes / Tubes: 1/4"-1.1/2"

Varilla / Rod / Boulon: 10mm-36mm









EQUIPO STANDARD / STANDARD EQUIPMENT / EQUIPEMENT STANDARD / STANDARDZUBEHÖR / EQUIPAGGIAMENTO STANDARD
EQUIPAMENTO STANDARD

| COD |  | V |  |  2 un |  |  |  2L |  |
|-------|--|----------|--|---|--|--|---|--|
| 60140 | BSPT | 230/50Hz | 81612 | 1/2-3/4", 1-1.1/2" | ● | ● | ● | 46 |
| 60141 | NPT | | | | | | | |
| 60142 | BSPT | 110/60Hz | | | | | | |
| 60143 | NPT | | | | | | | |

REPUESTOS / SPARE PARTS / RECHANGES / ERSATZTEILE / ACCESORI / TOEBEHOREN / ACESSORIOS

|  |  |  |  |  |  |  |  |  5L |
|---|---|---|---|---|--|---|---|--|
| 81612 | 81686 | 81617 | 81618 | 81614 | 81615 | 64104 | 64131 | 64002 |

| BSPT | | BSPT (HSS) | | NPT | | NPT (HSS) | |
|-------|---|------------|---|-------|---|-----------|---|
| COD |  | COD |  | COD |  | COD |  |
| 64108 | 1/4-3/8" | 64111 | 1/4-3/8" | 64114 | 1/4-3/8" | 64117 | 1/4-3/8" |
| 64109 | 1/2-3/4" | 64112 | 1/2-3/4" | 64115 | 1/2-3/4" | 64118 | 1/2-3/4" |
| 64110 | 1-1.1/2" | 64113 | 1-1.1/2" | 64116 | 1-1.1/2" | 64119 | 1-1.1/2" |

| METRICO / METRIC (HSS) | | BSW (HSS) | |
|------------------------|---|-----------|---|
| COD |  | COD |  |
| 64135 | 10 | 64120 | 3/8" |
| 64136 | 12 | 64121 | 1/2" |
| 64137 | 14-16 | 64122 | 5/8" |
| 64138 | 18-22 | 64123 | 3/4" |
| 64139 | 24-27 | 64124 | 7/8" |
| 64141 | 30-33 | 64125 | 1" |
| 64142 | 36 | 64126 | 1.1/8-1.1/4" |
| | | 64127 | 1.1/2" |

| PG (HSS) | |
|----------|--|
| COD |  |
| 64146 | PG9-PG16 |
| 64147 | PG21-PG36 |

MAQUINAS ROSCADORAS / PIPE THREADING MACHINES / FILIERES ELECTRIQUES GEWINDESCHNEIDMASCHINEN / FILETTATRICI ELETTRICA / DRAADSNIJMACHINES

ROSCAMATIC - 2

| CAP. | W | V | R.P.M. | |
|--------|-----|----------|--------|----|
| 1/4-2" | 750 | 230/50Hz | 22 | 65 |
| | | 110/60Hz | | |

Motor Asíncrono. / Condenser Motor. / Moteur de Condensateur.
Kondensatormotor. / Condensator Motor. / Motore Asincrono.
Motor Assíncrono.

Tubos / Pipes / Tubes: 1/4"-2"

Varilla / Rod / Boulon: 10mm-52mm



EQUIPO STANDARD / STANDARD EQUIPMENT / EQUIPEMENT STANDARD / STANDARDZUBEHÖR / EQUIPAGGIAMENTO STANDARD
EQUIPAMENTO STANDARD

| COD | | V | | 2un | | | | |
|-------|------|----------|-------|------------------|--|--|--|----|
| 60150 | BSPT | 230/50Hz | 81600 | 1/4-3/4" 1-2" | | | | 65 |
| 60151 | NPT | | | | | | | |
| 60152 | BSPT | 110/60Hz | | | | | | |
| 60153 | NPT | | | | | | | |

REPUESTOS / SPARE PARTS / RECHANGES / ERSATZTEILE / ACCESORI / TOEBEHOREN / ACESSORIOS

| BSPT-NPT-BSPP | BSW | METRIC | PG | | | | HSS | | |
|---------------|-------|--------|-------|-------|-------|-------|-------|-------|-------|
| 81600 | 81619 | 81620 | 81621 | 81601 | 81602 | 64104 | 64131 | 81603 | 64002 |

| BSPT | | BSPT (HSS) | | NPT | | NPT (HSS) | |
|-------|----------|------------|----------|-------|----------|-----------|----------|
| COD | | COD | | COD | | COD | |
| 64148 | 1/4-3/8" | 64151 | 1/4-3/8" | 64154 | 1/4-3/8" | 64157 | 1/4-3/8" |
| 64149 | 1/2-3/4" | 64152 | 1/2-3/4" | 64155 | 1/2-3/4" | 64158 | 1/2-3/4" |
| 64150 | 1-2" | 64153 | 1-2" | 64156 | 1-2" | 64159 | 1-2" |

| BSPP | | BSPP (HSS) | | METRICO / METRIC (HSS) | |
|-------|----------|------------|----------|------------------------|----------|
| COD | | COD | | COD | |
| 64495 | 1/4-3/8" | 64498 | 1/4-3/8" | 64180 | 10 |
| 64496 | 1/2-3/4" | 64499 | 1/2-3/4" | 64181 | 12 |
| 64497 | 1-2" | 64500 | 1-2" | 64182 | 14-16 |
| | | | | 64183 | 18-22 |
| | | | | 64184 | 24-27 |
| | | | | 64186 | 30-33 |
| | | | | 64187 | 36 |
| | | | | 64188 | 42-45 |
| | | | | 64189 | 48-50-52 |

| BSW (HSS) | | | |
|-----------|------|-------|--------------|
| COD | | COD | |
| 64160 | 3/8" | 64165 | 1" |
| 64161 | 1/2" | 64166 | 1.1/8-1.1/4" |
| 64162 | 5/8" | 64167 | 1.1/2" |
| 64163 | 3/4" | 64168 | 1.5/8-1.3/4" |
| 64164 | 7/8" | 64169 | 1.7/8-2" |

| PG (HSS) | |
|----------|------------|
| COD | |
| 64200 | PG9-PG16 |
| 64201 | PG21-PG36 |
| 64202 | PG42-PG-48 |

MAQUINAS PARA TUBO / PIPING MACHINES / MACHINES POUR TUBE ROHRMASCHINEN / MACCHINE PER TUBI / PIJPMACHINES / MÁQUINAS PARA TUBO

MAQUINAS ROSCADORAS / PIPE THREADING MACHINES / FILIERES ELECTRIQUES
GEWINDESCHNEIDMASCHINEN / FILETTATRICI ELETTRICA / DRAADSNIJMACHINES

ROSCAMATIC - 3

| CAP. | W | V | R.P.M. |  |
|--------|-----|----------|-----------------|---|
| 1/2-3" | 750 | 230/50Hz | (1/2-2") = 25 | 123 |
| | | 110/60Hz | (2.1/2-3") = 11 | |







Motor Asíncrono. / Condenser Motor. / Moteur de Condensateur.
Kondensatormotor. / Condensator Motor. / Motore Asincrono.
Motor Assíncrono.

Sistema de copiado de rosca. / Notch profiling die head. Copy
system. / Entaille profilant. / Le système principal de copie de
matrice. / Kerbe, Profiliert Schneidkopf inkl. Kopiersystem.
Profiel snijkop. / Sistema de filettatura a copiare.
Sistema de copiador de rosca.







Tubos / Pipes / Tubes: 1/2"-3"

EQUIPO STANDARD / STANDARD EQUIPMENT / EQUIPEMENT STANDARD / STANDARDZUBEHÖR / EQUIPAGGIAMENTO STANDARD
EQUIPAMENTO STANDARD

| COD |  | V |  2 un |  3 un |  |  |  5L |  |
|-------|--|----------|---|---|--|--|---|--|
| 60160 | BSPT | 230/50Hz | 1/2-2" | 1/2-3/4" | ● | ● | ● | 123 |
| 60161 | NPT | | | | | | | |
| 60162 | BSPT | 110/60Hz | 2.1/2-3" | 1-1/2" | ● | ● | ● | 123 |
| 60163 | NPT | | | | | | | |

REPUESTOS / SPARE PARTS / RECHANGES / ERSATZTEILE / ACCESORI / TOEBEHOREN / ACESSORIOS

|  1/2-2 |  2.1/2-3 |  |  |  |  HSS |  |  |
|---|---|---|---|--|---|---|---|
| 81604 | 81605 | 81606 | 81607 | 64104 | 64131 | 81603 | 64002 |

| BSPT | | BSPT (HSS) | | NPT | | NPT (HSS) | |
|-------|---|------------|---|-------|---|-----------|---|
| COD |  | COD |  | COD |  | COD |  |
| 64205 | 1/2-3/4" | 64209 | 1/2-3/4" | 64213 | 1/2-3/4" | 64217 | 1/2-3/4" |
| 64206 | 1-2" | 64210 | 1-2" | 64214 | 1-2" | 64218 | 1-2" |
| 64207 | 2.1/2-3" | 64211 | 2.1/2-3" | 64215 | 2.1/2-3" | 64219 | 2.1/2-3" |

EGA Master S.A.
ART IN INNOVATION

MAQUINAS ROSCADORAS / PIPE THREADING MACHINES / FILIERES ELECTRIQUES GEWINDESCHNEIDMASCHINEN / FILETTATRICI ELETTRICA / DRAADSNIJMACHINES

ROSCAMATIC - 3 "COMBI"

| CAP. | W | V | R.P.M. | Kg |
|--------|-----|----------|-----------------|-----|
| 1/2-3" | 750 | 230/50Hz | (1/2-2") = 25 | 102 |
| | | 110/60Hz | (2.1/2-3") = 11 | |

Motor Asíncrono. / Condenser Motor. / Moteur de Condensateur.
Kondensatormotor. / Condensator Motor. / Motore Asincrono.
Motor Assíncrono.

Sistema de copiado de rosca. / Notch profiling die head. Copy system. / Entaille profilant. / Le système principal de copie de matrice. / Kerbe, Profiliert Schneidkopf inkl. Kopiersystem. Profiel snijkop. / Sistema de filettatura a copiare. Sistema de copiador de rosca.



Tubos / Pipes / Tubes: 1/2"-3"

EQUIPO STANDARD / STANDARD EQUIPMENT / EQUIPEMENT STANDARD / STANDARDZUBEHÖR / EQUIPAGGIAMENTO STANDARD
EQUIPAMENTO STANDARD

| COD | Icon | V | 2 un | 3 un | Icon | Icon | 5L | Kg |
|-------|------|----------|--------------------|--------------------------------|------|------|----|-----|
| 60164 | BSPT | 230/50Hz | 1/2-2" 2.1/2-3" | 1/2-3/4" 1-1/2" 2.1/2-3" | ● | ● | ● | 102 |
| 60165 | NPT | | | | | | | |
| 60166 | BSPT | 110/60Hz | | | | | | |
| 60167 | NPT | | | | | | | |

REPUESTOS / SPARE PARTS / RECHANGES / ERSATZTEILE / ACCESORI / TOEBEHOREN / ACESSORIOS

| Icon | Icon | Icon | Icon | Icon | Icon | Icon | 5L |
|-------|-------|-------|-------|-------|-----------|-------|-------|
| 81604 | 81605 | 81606 | 81607 | 64104 | 64131 HSS | 81603 | 64002 |

| BSPT | | BSPT (HSS) | | NPT | | NPT (HSS) | |
|-------|----------|------------|----------|-------|----------|-----------|----------|
| COD | Icon | COD | Icon | COD | Icon | COD | Icon |
| 64205 | 1/2-3/4" | 64209 | 1/2-3/4" | 64213 | 1/2-3/4" | 64217 | 1/2-3/4" |
| 64206 | 1-2" | 64210 | 1-2" | 64214 | 1-2" | 64218 | 1-2" |
| 64207 | 2.1/2-3" | 64211 | 2.1/2-3" | 64215 | 2.1/2-3" | 64219 | 2.1/2-3" |

RANURADORA HIDRAULICA / HYDRAULIC ROLL GROOVER / RAINUREUSE HYDRAULIQUE / HYDRAULISCHE ROLLNUTMASCHINE
SCANALATORE IDRAULICO / HYDRAULISCHE ROLGROEVER / RANHURADORA HIDRAULICA

| COD | CAP | Kg | Icon |
|-------|-----------|----|------|
| 60185 | 1.1/4-12" | 23 | 1 |

Opcional / optional / optionnel



ACEITERA / OILER / BURETTE A HUILE / OIL KANISTER / OLIEKAN / OLIIATORI / ALMOTOLIA

| COD | CAP | Kg | Icon |
|-------|-----|----|------|
| 64130 | 5L | 3 | 1 |



MAQUINAS PARA TUBO / PIPING MACHINES / MACHINES POUR TUBE ROHRMASCHINEN / MACCHINE PER TUBI / PIJPMACHINES / MÁQUINAS PARA TUBO

MAQUINAS ROSCADORAS / PIPE THREADING MACHINES / FILIERES ELECTRIQUES
GEWINDESCHNEIDMASCHINEN / FILETTATRICI ELETTRICA / DRAADSNIJMACHINES

ROSCAMATIC - 4

| CAP. | W | V | R.P.M. |  |
|--------|-----|----------------------|----------------------------------|---|
| 1/2-4" | 750 | 230/50Hz 110/60Hz | (1/2-2") = 25 (2.1/2-4") = 11 | 150 |

Motor Asíncrono. / Condenser Motor. / Moteur de Condensateur.
Kondensatormotor. / Condensator Motor. / Motore Asincrono.
Motor Assíncrono.













Sistema de copiado de rosca. / Notch profiling die head. Copy system. / Entaille profilant. / Le système principal de copie de matrice. / Kerbe, Profiliert Schneidkopf inkl. Kopiersystem. Profiel snijkop. / Sistema de filettatura a copiare. Sistema de copiadór de rosca.

Tubos / Pipes / Tubes: 1/2"-4"

Varilla / Rod / Boulon: 10mm-52mm









EQUIPO STANDARD / STANDARD EQUIPMENT / EQUIPEMENT STANDARD / STANDARDZUBEHÖR / EQUIPAGGIAMENTO STANDARD
EQUIPAMENTO STANDARD



| COD |  | V |  2 un |  3 un |  |  |  2L |  |
|-------|--|----------|---|---|---|---|---|--|
| 60170 | BSPT | 230/50Hz | 1/2-2" 2.1/2-4" | 1/2-3/4" 1-2" 2.1/2-4" |  |  |  | 150 |
| 60171 | NPT | | | | | | | |
| 60172 | BSPT | 110/60Hz | 1/2-2" 2.1/2-4" | 1/2-3/4" 1-2" 2.1/2-4" |  |  |  | |
| 60173 | NPT | | | | | | | |

REPUESTOS / SPARE PARTS / RECHANGES / ERSATZTEILE / ACCESORI / TOEBEHOREN / ACESSORIOS

|  1/2-2" |  2.1/2-4" |  BSPP |  BSW |  METRIC |  PG |  |  |  |  HSS |  5L | |
|--|--|--|---|--|--|---|--|---|---|--|-------|
| 81608 | 81609 | 81687 | 81721 | 81616 | 81795 | 81610 | 81611 | 64104 | 64131 | 81603 | 64002 |

| BSPT | | BSPT (HSS) | | NPT | | NPT (HSS) | |
|-------|---|------------|---|-------|---|-----------|---|
| COD |  | COD |  | COD |  | COD |  |
| 64205 | 1/2-3/4" | 64209 | 1/2-3/4" | 64213 | 1/2-3/4" | 64217 | 1/2-3/4" |
| 64206 | 1-2" | 64210 | 1-2" | 64214 | 1-2" | 64218 | 1-2" |
| 64208 | 2.1/2-4" | 64212 | 2.1/2-4" | 64216 | 2.1/2-4" | 64220 | 2.1/2-4" |

| BSPP | | BSPP (HSS) | | METRICO / METRIC (HSS) | |
|-------|---|------------|---|------------------------|---|
| COD |  | COD |  | COD |  |
| 64495 | 1/4-3/8" | 64498 | 1/4-3/8" | 64180 | 10 |
| 64496 | 1/2-3/4" | 64499 | 1/2-3/4" | 64181 | 12 |
| 64497 | 1-2" | 64500 | 1-2" | 64182 | 14-16 |
| | | | | 64183 | 18-22 |
| | | | | 64184 | 24-27 |
| | | | | 64186 | 30-33 |
| | | | | 64187 | 36 |
| | | | | 64188 | 42-45 |
| | | | | 64189 | 48-50-52 |

| BSW (HSS) | | | |
|-----------|---|-------|---|
| COD |  | COD |  |
| 64160 | 3/8" | 64165 | 1" |
| 64161 | 1/2" | 64166 | 1.1/8-1.1/4" |
| 64162 | 5/8" | 64167 | 1.1/2" |
| 64163 | 3/4" | 64168 | 1.5/8-1.3/4" |
| 64164 | 7/8" | 64169 | 1.7/8-2" |

| PG (HSS) | |
|----------|---|
| COD |  |
| 64200 | PG9-PG16 |
| 64201 | PG21-PG36 |
| 64202 | PG42-PG-48 |

MAQUINAS ROSCADORAS / PIPE THREADING MACHINES / FILIERES ELECTRIQUES
GEWINDESCHNEIDMASCHINEN / FILETTATRICI ELETTRICA / DRAADSNIJMACHINES

ROSCAMATIC - 6

| CAP. | W | V | R.P.M. | |
|-----------|------|----------|-----------------|-----|
| 2.1/2"-6" | 1100 | 230/50Hz | (2.1/2-4") = 16 | 210 |
| | | 110/60Hz | (5-6") = 6 | |

Motor Asíncrono. / Condenser Motor. / Moteur de Condensateur.
Kondensatormotor. / Condensator Motor. / Motore Asíncrono.
Motor Assíncrono.

Sistema de copiado de rosca. / Notch profiling die head. Copy system. / Entaille profilant. / Le système principal de copie de matrice. / Kerbe, Profiliert Schneidkopf inkl. Kopiersystem. Profiel snijkop. / Sistema de filettatura a copiare. Sistema de copiadador de rosca.



Tubos / Pipes / Tubes: 2.1/2"-6"

EQUIPO STANDARD / STANDARD EQUIPMENT / EQUIPEMENT STANDARD / STANDARDZUBEHÖR / EQUIPAGGIAMENTO STANDARD
EQUIPAMENTO STANDARD

| COD | | V | 2 un | 2 un | | | | |
|-------|------|----------|----------|----------|---|---|---|-----|
| 60190 | BSPT | 230/50Hz | 2.1/2-4" | 2.1/2-4" | ● | ● | ● | 210 |
| 60191 | NPT | | | | | | | |
| 60192 | BSPT | 110/60Hz | 5-6" | 5-6" | ● | ● | | |
| 60193 | NPT | | | | | | | |

REPUESTOS / SPARE PARTS / RECHANGES / ERSATZTEILE / ACCESORI / TOEBEHOREN / ACESSORIOS

| 2.1/2-4 | 5-6 | | | | HSS | |
|---------|-------|-------|-------|-------|-------|-------|
| 81622 | 81623 | 81624 | 81625 | 64271 | 64132 | 81603 |
| | | | | | | 64002 |

| BSPT | | BSPT (HSS) | | NPT | | NPT (HSS) | |
|-------|----------|------------|----------|-------|----------|-----------|----------|
| COD | | COD | | COD | | COD | |
| 64208 | 2.1/2-4" | 64212 | 2.1/2-4" | 64216 | 2.1/2-4" | 64220 | 2.1/2-4" |
| 64221 | 5-6" | 64223 | 5-6" | 64222 | 5-6" | 64224 | 5-6" |

EGA Master S.A.

ART IN INNOVATION

ACCESORIOS / SPARE PARTS / RECHANGES / ERSATZTEILE / ACCESSORI
TOEBEHOREN / ACESSORIOS

CARRO HIDRAULICO / HYDRAULIC TROLLEY / CHARIOT HYDRAULIQUE / ARBEITSWAGEN HYDRAULISCH / HYDRAULYSCH KAR
CARRELLO IDRAULICO / CARRO HIDRAULICO

| COD | A-B | L min - max | CAP | Kg | |
|-------|---------|----------------|-------|-----|---|
| 60184 | 600-900 | 295-1020 | 500kg | 123 | 1 |



CARRO MANUAL / HAND TROLLEY / CHARIOT MANUEL / HANDGESTELL / HANDKARRE / CARRELLO MANUALE / CARRO MANUAL

| COD | | Kg | |
|-------|--------------|------|---|
| 60181 | ROSCAMATIC-2 | 30,5 | 1 |
| 60180 | ROSCAMATIC-3 | 28,2 | |
| 60182 | ROSCAMATIC-4 | 28,4 | |
| 60183 | ROSCAMATIC-6 | 30 | |



SOPORTE PARA TUBOS / PIPE BRACKET / SUPPORT PER TUBES / ROHRHALTEWINKEL / PIJPESTEUN / SUPPORTO PER TUBI /
SUPORTE PARA TUBOS

| COD | L min - max | Kg | |
|-------|----------------|----|---|
| 60179 | 750-1200 | 5 | 1 |



ACEITERA / OILER/ CUVE À HUILE / ÖLWANNE / OLIEKAN / OLIIATORI / ALMOTOLIA

| COD | CAP | Kg | |
|-------|-----|----|---|
| 64130 | 5L | 3 | 1 |



ACEITE DE CORTE / CUTTING OIL / HUILE DE COUPE / GEWINDESCHNEIDÖL / OLIO DATAGLIO / DRAADSNIJOLIE / OLEO DE CORTE

| COD | CAP | Kg | |
|-------|-----|-----|---|
| 64006 | 2L | 2 | 1 |
| 64002 | 5L | 4,5 | |



**MAQUINAS ROSCADORAS / PIPE THREADING MACHINES / FILIERES ELECTRIQUES
GEWINDESCHNEIDMASCHINEN / FILETTATRICI ELETTRICA / DRAADSNIJMACHINES**
MASTERMATIC - 1

| CAP. | W | V | Kg. |
|--------|------|----------------------|-----|
| 1-1/4" | 1150 | 230/50Hz 110/60Hz | 5,9 |

CABEZAS DE TERRAJA: Especialmente diseñadas con una mayor longitud para un asentamiento más preciso de los peines proporcionando una mejor rosca y más suavidad en el trabajo.

THREADING HEADS: Specially designed and enlarged heads providing more precise dies setting for smoother and better threading.

FILIERES: Les filières sont spécialement conçues pour fixer plus précisément les peignes. Il en résulte une plus grande qualité de filetage.

SCHNEIDKÖPFE: Spezial entwickelte Schneidköpfe für eine genauere Einstellung der Schneidbacken sowie ein besseres Gewinde.

SNIJKOPPEN: De speciale snijkoppen geven een meer preciese en betere draadkwaliteit.

TESTE: Fatti con una guida allungata per facilitare l'infilamento del tubo e la estrazione dalla testa. Coperchio di precisione meccanizzato per un'ottima guida dei pettini e sopra-dimensionato per un'assorbimento corretto della forza di lavoro.

CABEÇAS DE TARRACHA: Especialmente desenhadas com uma maior longitude para um assentamento mais preciso dos caçonetes, proporcionando uma melhor rosca e mais suavidade no trabalho.



| | | | | | | 230V | 110V | | | |
|------|------|------|------|----|--------|-------------|------------|-------------|------------|-------|
| 1/4" | 3/8" | 1/2" | 3/4" | 1" | 1.1/4" | COD BSPT | COD NPT | COD BSPT | COD NPT | Kg |
| - | - | ● | ● | ● | ● | 69082 | 69087 | 69092 | 69097 | 13,40 |
| - | ● | ● | ● | ● | ● | 69083 | 69088 | 69093 | 69098 | 14 |
| ● | ● | ● | ● | ● | ● | 69084 | 69089 | 69094 | 69099 | 14,6 |

230V
60130
110V
60131

50000

81530

64001
ACEITERA / OILER / BURETTE A HUILE / OIL KANISTER / OLIEKAN / OLIIATORI / ALMOTOLIA

| COD | CAP | Kg | |
|-------|-----|----|---|
| 64130 | 5L | 3 | 1 |



MAQUINAS PARA TUBO / PIPING MACHINES / MACHINES POUR TUBE ROHRMASCHINEN / MACCHINE PER TUBI / PIJPMACHINES / MÁQUINAS PARA TUBO

MAQUINAS ROSCADORAS / PIPE THREADING MACHINES / FILIERES ELECTRIQUES
GEWINDESCHNEIDMASCHINEN / FILETTATRICI ELETTRICA / DRAADSNIJMACHINES

MASTERMATIC - 2

| CAP. | W | V | Kg |
|------|------|----------|-----|
| 2" | 1350 | 230/50Hz | 8,1 |
| | | 110/60Hz | |

CABEZAS DE TERRAJA: Especialmente diseñadas con una mayor longitud para un asentamiento más preciso de los peines proporcionando una mejor rosca y más suavidad en el trabajo.

THREADING HEADS: Specialty designed and enlarged heads providing more precise dies setting for smoother and better threading.

FILIERES: Les filières sont spécialement conçue pour fixer plus précisément les peignes. Il en résulte une plus grande qualité de filetage.

SCHNEIDKÖPFE: Spezial entwickelte Schneidköpfe für eine genauere Einstellung der Schneidbacken sowie ein besseres Gewinde.

SNIJKOPPEN: De speciale snijkoppen geven een meer preciese en betere draadkwaliteit.

TESTE: Fatti con una guida allungata per facilitare l'infilamento del tubo e la estrazione dalla testa. Coperchio di precisione meccanizzato per un'ottima guida dei pettini e sopra-dimensionato per un'assorbimento corretto della forza di lavoro.

CABEÇAS DE TARRACHA: Especialmente desenhadas com uma maior longitude para um assentamento mais preciso dos caçonetes, proporcionando uma melhor rosca e mais suavidade no trabalho.



| | | | | | | | | 230V | | 110V | | Kg |
|------|------|------|------|----|--------|--------|----|-------------|------------|-------------|------------|-------|
| 1/4" | 3/8" | 1/2" | 3/4" | 1" | 1.1/4" | 1.1/2" | 2" | COD BSPT | COD NPT | COD BSPT | COD NPT | |
| - | - | ● | ● | ● | ● | ● | ● | 69114 | 69121 | 69174 | 69181 | 13,40 |
| - | ● | ● | ● | ● | ● | ● | ● | 69115 | 69122 | 69175 | 69182 | 14 |
| ● | ● | ● | ● | ● | ● | ● | ● | 69116 | 69123 | 69176 | 69183 | 14,6 |

| | | | | | |
|-------|-------|-------|-------|-------|-------|
| | | | | | |
| 230V | 110V | | | | |
| 60132 | 60133 | 51020 | 81626 | 80833 | 64001 |

ACEITERA / OILER / BURETTE A HUILE / OIL KANISTER / OLIEKAN / OLIIATORI / ALMOTOLIA

| COD | CAP | Kg | |
|-------|-----|----|---|
| 64130 | 5L | 4 | 1 |



RANURADORA HIDRAULICA / HYDRAULIC ROLL GROOVER / RAINUREUSE HYDRAULIQUE
HYDRAULISCHE ROLLNUTMASCHINE / SCANALATORE IDRAULICO
HYDRAULISCHE ROLGROEVER / RANHURADORA HIDRÁULICA

RANUMATIC "COMBI"

| CAP. | W | V | R.P.M. | |
|------------|-----|----------------------|---------------------------------|-----|
| 1.1/4"-12" | 750 | 230/50Hz 110/60Hz | (1.1/4-6") = 25 (8-12") = 11 | 108 |

Motor Asíncrono. / Condenser Motor. / Moteur de Condensateur.
Kondensatormotor. / Condensator Motor. / Motore Asíncrono.
Motor Assíncrono.

Tubos / Pipes / Tubes: 1.1/4"-12"



CAPACIDAD DE RANURADO DE TUBOS / PIPE GROOVING CAPACIT / DIAMÉTRE MAXIMUM DE RAINURAGE / KAPAZITÄT DER ROHR-
NUTEN / CAPACITA DI SCANALATURA DEL TUBO / PIJIP DIE CAPACITEIT GROEFT / CAPACIDADE DE RANHURAGEM DE TUBO

| | 1.1/4" | 1.1/2" | 2" | 2.1/2" | 3" | 4" | 6" | 8" | 10" | 12" |
|--------------------|--------|--------|------|--------|------|-----|------|-----|-----|-----|
| SCHEDULE 10 | 2,8 | 2,8 | 2,8 | 3 | 3 | 3,4 | 3,4 | 3,8 | 4,2 | 4,6 |
| SCHEDULE 40 | 3,6 | 3,4 | 3,9 | 5,2 | 5,5 | 6 | 7,1 | 8,2 | - | - |
| DIN 2440 | 3,25 | 3,25 | 3,65 | 3,65 | 4,03 | 4,5 | 4,85 | - | - | - |

INOX - hasta 4,8 mm
up to 4,8 mm

EQUIPO STANDARD / STANDARD EQUIPMENT / EQUIPEMENT STANDARD / STANDARDZUBEHÖR / EQUIPAGGIAMENTO STANDARD
EQUIPAMENTO STANDARD

| COD | V | | | | |
|-------|-----|-------------------|--|--|-----|
| 60168 | 230 | 1.1/4-6" 8-12" | | | 108 |
| 60169 | 110 | | | | |

REPUESTOS / SPARE PARTS / RECHANGES / ERSATZTEILE / ACCESORI / TOEBEHOREN / ACESSORIOS

| 1.1/4"-6" 60174 | 8"-12" 60175 | 81603 | 60176 |
|--------------------|-----------------|-------|-------|

CARRO DE ROSCAR 3" / THREADING CARRIAGE / CHARRIOT DE FILETAGE 3" / GEWINDESCHNEID-WERKZEUGHALTER /
WERKHOUDER VOOR DRAADSNIJMACHINE / CARRO DE ROSCAR 3"

| COD | | 2 un | 3 un | | | |
|-------|------|----------|------------------|--|--|-----|
| 60186 | BSPT | 1/2-2" | 1/2-3/4" | | | 102 |
| 60189 | NPT | 2.1/2-3" | 1-1/2", 2.1/2-3" | | | |

Opcional / optional / optionnel



CABALLETE / PIPE SUPPORT / SUPPORT DE TUBE / ROHRHALTEWINKEL / CAVALLETTO PER TUBI / PIJIPSTEUN / CAVALETE PARA
TUBO

| COD | | |
|-------|-----|---|
| 60176 | 7,4 | 1 |



MAQUINAS PARA TUBO / PIPING MACHINES / MACHINES POUR TUBE ROHRMASCHINEN / MACCHINE PER TUBI / PIJPMACHINES / MÁQUINAS PARA TUBO

ROSCADORA PARA TUBO DE PLASTICO / PLASTIC PIPE THREADING MACHINE / FILIERE
POUR PLASTIQUE / GEWINDESCHNEIDER FÜR PLASTIK / FILIERA PER PLASTICA
RAAADSNIJKOP VOOR PLASTIEK BUIS / ROSCADORA PARA PLÁSTICO

ROSCAPLASTIC

| CAP. | W | V | R.P.M. | Kg |
|--------|-----|----------|--------|----|
| 1/4-2" | 750 | 230/50Hz | 60 | 63 |
| | | 110/60Hz | | |

Motor Asíncrono. / Condenser Motor. / Moteur de Condensateur.
Kondensatormotor. / Condensator Motor. / Motore Asincrono. /
Motor Assíncrono.



EQUIPO STANDARD / STANDARD EQUIPMENT / EQUIPEMENT STANDARD / STANDARDZUBEHÖR / EQUIPAGGIAMENTO STANDARD
EQUIPAMENTO STANDARD

| COD | | V | | | Kg |
|-------|------|----------|-------|------------------|----|
| 60209 | BSPT | 230/50Hz | 81600 | 1/2-3/4" 1-2" | 63 |
| 60210 | NPT | | | | |
| 60211 | BSPT | 110/60Hz | | | |
| 60212 | NPT | | | | |

REPUESTOS / SPARE PARTS / RECHANGES / ERSATZTEILE / ACCESORI / TOEBEHOREN / ACESSORIOS

| BSPT-NPT | BSW | METRIC | PG | |
|----------|-------|--------|-------|-------|
| 81600 | 81619 | 81620 | 81621 | 81603 |

BSPT

| COD | |
|-------|----------|
| 64148 | 1/4-3/8" |
| 64149 | 1/2-3/4" |
| 64150 | 1-2" |

NPT

| COD | |
|-------|----------|
| 64154 | 1/4-3/8" |
| 64155 | 1/2-3/4" |
| 64156 | 1-2" |

METRICO / METRIC (HSS)

| COD | | COD | |
|-------|-------|-------|----------|
| 64180 | 10 | 64184 | 24-27 |
| 64181 | 12 | 64186 | 30-33 |
| 64182 | 14-16 | 64187 | 36 |
| 64183 | 18-22 | 64188 | 42-45 |
| | | 64189 | 48-50-52 |

BSW (HSS)



| COD | | COD | |
|-------|------|-------|--------------|
| 64160 | 3/8" | 64165 | 1" |
| 64161 | 1/2" | 64166 | 1.1/8-1.1/4" |
| 64162 | 5/8" | 64167 | 1.1/2" |
| 64163 | 3/4" | 64168 | 1.5/8-1.3/4" |
| 64164 | 7/8" | 64169 | 1.7/8-2" |

PG (HSS)



| COD | |
|-------|------------|
| 64200 | PG9-PG16 |
| 64201 | PG21-PG36 |
| 64202 | PG42-PG-48 |

SIERRA DE CINTA / ELECTRIC BANDSAW / SCIE A RUBAN / BANDSÄGE / METAAL BANDZAAG / SEGA DI NASTRO
SERRA DE FITA



MULTIFUNCION / MULTIFUNCTION / MULTIFUNKTIONS / MULTIFUNÇÕES

| COD | CAP ● | CAP ■ | W | V |  | Kg  |
|-------|----------|----------|---|-----|---|---|
| 60128 | 115 | 120x115 | 320 | 230 | 1356x13x0,65 | 21 |
| 60129 | | | | 110 | | |
| COD | | |  | | | |
| 64311 | | | 1356x13x0,65 - 14 | | | |
| 64312 | | | 1356x13x0,65 - 18 | | | |

 CABEZAL PORTATIL / PORTABLE BHEAD / TETE PORTABLE
TRAGBARER KOPF / TESTA PORTATILE / CABEÇA PORTATIL

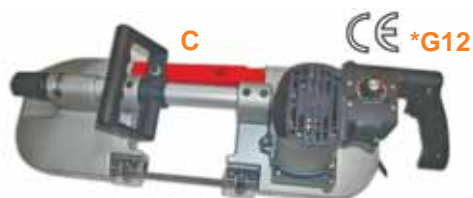
| COD | CAP ● | CAP ■ | W | V |  | Kg  |
|-------|----------|----------|---|-----|---|---|
| 60220 | 115 | 120x115 | 320 | 230 | 1356x13x0,65 | 10 |
| 60221 | | | | 110 | | |
| COD | | |  | | | |
| 64311 | | | 1356x13x0,65 - 14 | | | |
| 64312 | | | 1356x13x0,65 - 18 | | | |

 SIERRA ELECTROPORTATIL / RECIPROCATING SAW / SCIE SABRE UNIVERSELLE / TRAGBARE ELEKTROSÄGE
SEGHETO ELETRICO / SERRA ELECTRO PORTATIL

| COD | CAP metal / wood | W | R.P.M. | V | Kg  |
|---------------|---------------------|---|--------|-----|---|
| 60216 | 90/115 | 750 | 2500 | 230 | 5,2 |
| 60217 | | | | 110 | |
| COD | |  | | | |
| 64411 (metal) | | 152x0,9 - 25,5 | | | |
| 64412 (wood) | | 152x1,2 - 10,5 | | | |



MAQUINAS PARA TUBO / PIPING MACHINES / MACHINES POUR TUBE ROHRMASCHINEN / MACCHINE PER TUBI / PIJPMACHINES / MÁQUINAS PARA TUBO

CORTATUBOS PROPULSADO / POWER PIPE CUTTER / COUPE TUBE ELECTRIQUE
ROHRTRENNGERÄT / TAGLIATUBI ALIMENTATO / ELEKTRISCHE PIJPSNIJDER CORTA
TUBOS ELECTRO/HIDRÁULICO

KIT CORTAMATIC - 12

SET CON MASTERMATIC-2 / SET INCLUDING MASTERMATIC-2 / SET INCLUS MASTERMATIC-2 / SET INCLUSIVE MASTERMATIC-2
ASSORTIMENTO CON MASTERMATIC 2 / SET INCLUSIEF MASTERMATIC-2 / CONJUNTO COM MASTERMATIC 2

| COD | V | CAP | Kg |
|-------|-----|-----------|------|
| 60000 | 230 | 2.1/2-12" | 74,7 |
| 60001 | 110 | | |



CORTAMATIC - 12

| COD | CAP | Kg |
|-------|-----------|------|
| 60002 | 2.1/2-12" | 66,6 |



REPUESTOS / SPARE PARTS / RECHANGES / ERSATZTEILE / ACCESORI / TOEBEHOREN / ACESSORIOS



60003



60017



60018

CONGELADOR DE TUBO / PIPE FREEZER / CONGÉLATEUR DE TUBE ROHR-EINFRIERGERÄT / CONGELATUBI / BUISBEVRIEZER

MASTERFREEZE

| Ø | | t. | Ø | | t. |
|---------|------|------|--------|------|-------|
| 1/8" | (Fe) | 1min | 1" | (Fe) | 7min |
| 10-12mm | (Cu) | | 35mm | (Cu) | |
| 1/4" | (Fe) | 1min | 1.1/4" | (Fe) | 11min |
| 14-15mm | (Cu) | | 42mm | (Cu) | |
| 3/8" | (Fe) | 2min | 1.1/2" | (Fe) | 16min |
| 16-18mm | (Cu) | | 54mm | (Cu) | |
| 1/2" | (Fe) | 3min | 2" | (Fe) | 29min |
| 22mm | (Cu) | | 60mm | (Cu) | |
| 3/4" | (Fe) | 5min | | | |
| 28mm | (Cu) | | | | |



EQUIPO STANDARD / STANDARD EQUIPMENT / EQUIPEMENT STANDARD / STANDARDZUBEHÖR / EQUIPAGGIAMENTO STANDARD
EQUIPAMENTO STANDARD

| COD | | CAP (Cu) | CAP (Fe) | Kg | |
|-------|------|----------|----------|----|---|
| 60275 | EUR. | 10-60mm | 1/8"-2" | 5 | 1 |
| 60276 | USA | 1/4"-2" | | | |

REPUESTOS / SPARE PARTS / RECHANGES / ERSATZTEILE / ACCESORI / TOEBEHOREN / ACESSORIOS

| COD | EUR. | (Cu) | (Fe) | COD | USA | (Cu) | (Fe) |
|-------|------|---------|--------|-------|-----|--------|--------|
| 64460 | | 10-12mm | 1/8" | 64470 | | 1/4" | 1/8" |
| 64461 | | 14-15mm | 1/4" | 64471 | | 3/8" | 1/4" |
| 64462 | | 16-18mm | 3/8" | 64472 | | 1/2" | 3/8" |
| 64463 | | 22mm | 1/2" | 64473 | | 3/4" | 1/2" |
| 64464 | | 28mm | 3/4" | 64474 | | 1" | 3/4" |
| 64465 | | 35mm | 1" | 64475 | | 1.1/4" | 1" |
| 64466 | | 42mm | 1.1/4" | 64476 | | 1.1/2" | 1.1/4" |
| 64467 | | - | 1.1/2" | 64477 | | - | 1.1/2" |
| 64468 | | 54mm | - | 64478 | | 2" | - |
| 64469 | | 60mm | 2" | 64479 | | - | 2" |



CONEXION ALARGADERA / EXTENSION ADAPTOR / ADAPTATEUR DE PROLONGATEUR / VERLÄNGERUNGSVERBINDUNG
ADATTATORE PER ESTENSIONE / UITBREIDINGSADAPTOR / CONEÇÃO PARA EXTENSÃO

| COD | | 9F | |
|-------|--|----|---|
| 64480 | | 30 | 1 |



ALARGADERA / EXTENSION / RALLONGE / VERLÄNGERUNG / PROLUNGA VERLENGSTUK / EXTENSÃO

| COD | | 9F | |
|-------|--|----|---|
| 64481 | | 30 | 1 |



MAQUINAS PARA TUBO / PIPING MACHINES / MACHINES POUR TUBE ROHRMASCHINEN / MACCHINE PER TUBI / PIJPMACHINES / MÁQUINAS PARA TUBO





CONGELADOR ELECTRICO PARA TUBO / ELECTRIC PIPE FREEZER / CONGÉLATEUR
ELECTRIQUE À TUBES / ROHR-EINFRIERGERÄT, ELEKTREISCH / CONGELATUBI ELETTRICO
ELECTRISCHE BUISBEVRIEZER

FREEZEMATIC

| Ø |  | t. | Ø |  | t. |
|---------|---|--------|--------|---|---------|
| 1/8" | (Fe) | 3min | 3/4" | (Fe) | 14,5min |
| 10-12mm | (Cu) | 3,5min | 28mm | (Cu) | 17min |
| 1/4" | (Fe) | 4min | 1" | (Fe) | 18min |
| 14-15mm | (Cu) | 5,5min | | (Cu) | 20min |
| 3/8" | (Fe) | 6min | 1.1/4" | (Fe) | 31min |
| 16-18mm | (Cu) | 7min | | (Cu) | 33min |
| 1/2" | (Fe) | 9min | 42mm | (Fe) | 31min |
| 22mm | (Cu) | 11min | | (Cu) | 33min |



EQUIPO STANDARD / STANDARD EQUIPMENT / EQUIPEMENT STANDARD / STANDARDZUBEHÖR / EQUIPAGGIAMENTO STANDARD
EQUIPAMENTO STANDARD

| COD | V | CAP (Cu)  | CAP (Fe)  | Kg  |  |
|-------|-----|--|---|--|---|
| 60277 | 230 | 10-42mm | 1/8"-1.1/4" | 23 | 1 |
| 60278 | 110 | | | | |

ACCESORIOS / ACCESSORIES / ACCESSOIRES / ZUBEHÖR / ACCESSORI / TOEBEHOREN / ACESSORIOS

| COD | CAP (Fe)  | gr  |  |
|-------|--|--|---|
| 64482 | 1.1/2" | 800 | 1 |
| 64483 | 2" | | |





**HERRAMIENTA PARA COBRE / TOOLS FOR COPPER / OUTILLAGE POUR LE CUIVRE
WERKZEUG FÜR KUPFER / UTENSILI PER RAME / GEREEDSCHAPPEN VOOR KOPER
FERRAMENTAS PARA COBRE**

CORTATUBOS UNIQUE UNIQUE TUBE CUTTER COUPE-TUBES UNIQUE



Medalla de Oro, Salon Internacional de la Invención, París 2004
Gold Medal, International Inventors Competition, Paris 2004
Medaille d'Or, Salon International de L'Invention, Paris 2004

1 Acción rápida y suave gracias a su mecanizado de precisión.
Precision machining provides the quickest and smoothest action.
Action rapide et douce, grâce à son usinage très précis.

2 Extremadamente robusto, compacto y fácil de usar.
Extremely robust, compact and easy to use.
Très robuste, compact et aisé à utiliser.

3 Escala graduada marcada en láser para facilitar el posicionamiento.
Laser marked graduated scale to facilitate working action.
Echelle graduée, marquée au laser, pour faciliter le positionnement.

4 Cuchilla de repuesto incluida en el pomo.
Extra cutting wheel at the knob.
Molette de rechange, incluse dans le manche.

5 Puede cortar tubos de cobre, acero inoxidable y plástico con las cuchillas correspondientes.
Able to cut copper, inox and plastic pipes with the proper cutting wheels.
Il peut couper du cuivre, de l'inox et du plastique avec les molettes correspondantes.

6 Escariador extraíble puede trabajar montado en el cortatubos o de forma independiente.
Extractable reamer can work assembled in the tubing cutter or independently.
L'alésoir extractif peut travailler assemblé au coupe-tubes ou de manière indépendante.

7 Patentado
Patented
Breveté



CORTATUBOS / TUBE CUTTER / COUPE-TUBES / KUPFER ROHRABSCHNEIDER / TAGLIATUBI BI PIJPSNIJDER / CORTA TUBOS

SERIE CU = COBRE - COPPER - CUIVRE

MINI

| COD | MAT. | O.D. | RF | | | | |
|-------|------|------|-----|----|---|-------|----|
| 63176 | CU | 16 | 90 | 20 | 1 | 63088 | 20 |
| 63106 | CU | 22 | 120 | | | | |

MINI 30

| COD | MAT. | O.D. | RF | | | | |
|-------|------|------|-----|----|---|-------|----|
| 63168 | CU | 30 | 215 | 12 | 1 | 63086 | 20 |

CLASSIC 32

| COD | MAT. | O.D. | RF | | | | |
|-------|------|------|-----|----|---|-------|----|
| 63170 | CU | 32 | 300 | 12 | 1 | 63110 | 20 |

TELESCOPIC 32

| COD | MAT. | O.D. | RF | | | | |
|-------|------|------|-----|----|---|-------|----|
| 63105 | CU | 32 | 290 | 12 | 1 | 63110 | 20 |

UNIQUE 42

| COD | MAT. | O.D. | RF | | | | |
|-------|------|------|-----|---|---|-------|----|
| 63119 | CU | 42 | 575 | 8 | 1 | 63111 | 10 |

UNIQUE 45

| COD | MAT. | O.D. | RF | | | | |
|-------|------|------|-----|---|---|-------|----|
| 63187 | CU | 45 | 610 | 8 | 1 | 63111 | 10 |

AUTOMATIC 50

| COD | MAT. | O.D. | RF | | | | |
|-------|------|------|-----|---|---|-------|----|
| 63363 | CU | 50 | 450 | 8 | 1 | 63720 | 10 |

AUTOMATIC 67

| COD | MAT. | O.D. | RF | | | | |
|-------|------|------|-----|---|---|-------|----|
| 63107 | CU | 67 | 750 | 6 | 1 | 63111 | 10 |

AUTOMATIC 127

| COD | MAT. | O.D. | RF | | | | |
|-------|------|--------|------|---|---|-------|----|
| 63174 | CU | 50-127 | 1950 | 1 | 1 | 64106 | 10 |

KIT 3

| COD | | | | | | | |
|-------|-----------------------|--|--|--|--|--|--|
| 69465 | 63106 - 63170 - 63119 | | | | | | |

ROLLCUT

| COD | MAT. | O.D. | RF | | | | |
|-------|------|------|-----|---|---|-------|----|
| 63210 | CU | 12 | 235 | 6 | 1 | 63243 | 10 |
| 63211 | CU | 15 | 225 | | | | |
| 63212 | CU | 18 | 255 | | | | |
| 63213 | CU | 22 | 245 | | | | |



HERRAMIENTA PARA INOX / TOOLS FOR S/S / OUTILLAGE POUR LE INOX WERKZEUGE FÜR INOX / UTENSILI PER ACCIAIO INOX GEREEDSCHAPPEN VOOR INOX / FERRAMENTAS PARA AÇO INOXIDAVEL

CORTATUBOS / TUBE CUTTER / COUPE-TUBES / KUPFER ROHRABSCHNEIDER
TAGLIATUBI PIJPSNIJDER / CORTA TUBOS

SERIE INOX / STAINLESS STEEL / INOX / ACCIAIO INOX / AÇO INOXIDAVEL

MINI

| COD | MAT. | O.D. | BF | | | | |
|-------|------|------|-----|----|---|-------|----|
| 63190 | INOX | 16 | 90 | 20 | 1 | 63089 | 20 |
| 63096 | | 22 | 120 | | | | |



MINI 30

| COD | MAT. | O.D. | BF | | | | |
|-------|------|------|-----|----|---|-------|----|
| 63169 | INOX | 30 | 215 | 12 | 1 | 63087 | 20 |



CLASSIC 32

| COD | MAT. | O.D. | BF | | | | |
|-------|------|------|-----|----|---|-------|----|
| 63094 | INOX | 32 | 300 | 12 | 1 | 63113 | 20 |



TELESCOPIC 32

| COD | MAT. | O.D. | BF | | | | |
|-------|------|------|-----|----|---|-------|----|
| 63118 | INOX | 32 | 290 | 12 | 1 | 63113 | 20 |



UNIQUE 42

| COD | MAT. | O.D. | BF | | | | |
|-------|------|------|-----|---|---|-------|----|
| 63121 | INOX | 42 | 575 | 8 | 1 | 63114 | 10 |



UNIQUE 45

| COD | MAT. | O.D. | BF | | | | |
|-------|------|------|-----|---|---|-------|----|
| 63188 | INOX | 45 | 610 | 8 | 1 | 63114 | 10 |



AUTOMATIC 50

| COD | MAT. | O.D. | BF | | | | |
|-------|------|------|-----|---|---|-------|----|
| 63364 | INOX | 50 | 450 | 8 | 1 | 63721 | 10 |



AUTOMATIC 67

| COD | MAT. | O.D. | BF | | | | |
|-------|------|------|-----|---|---|-------|----|
| 63126 | INOX | 67 | 750 | 6 | 1 | 63114 | 10 |



KIT 3

| COD | |
|-------|-----------------------|
| 69548 | 63096 - 63094 - 63121 |



ESCARIADORES / REAMERS / ALESOIR / ENTGRATER / SBAVATORI / ONTBRAMERS

| COD | | | | | | |
|-------|---|----|----|---|-------|-------|
| 63371 | CU / ACERO / PLASTICO / INOX CU / STEEL / PLASTIC / INOX | 90 | 20 | 1 | 64008 | 64447 |
| 63375 | LATON / FUNDICION BRASS / CAST IRON | | | | 64446 | 64448 |



| COD | | | | | | |
|-------|---|----|----|---|-------|---|
| 63370 | CU / ACERO / PLASTICO / INOX CU / STEEL / PLASTIC / INOX | 50 | 20 | 1 | 64008 | - |
| 63374 | LATON / FUNDICION BRASS / CAST IRON | | | | 64446 | - |



| COD | | | | | | |
|-------|---|----|----|---|-------|---|
| 63369 | CU / ACERO / PLASTICO / INOX CU / STEEL / PLASTIC / INOX | 25 | 20 | 1 | 64008 | - |
| 63373 | LATON / FUNDICION BRASS / CAST IRON | | | | 64446 | - |



| COD | | | | | | |
|-------|---|----|----|---|-------|---|
| 63368 | CU / ACERO / PLASTICO / INOX CU / STEEL / PLASTIC / INOX | 10 | 20 | 1 | 64008 | - |
| 63372 | LATON / FUNDICION BRASS / CAST IRON | | | | 64446 | - |



| COD | | | | |
|-------|----|-----|----|---|
| 63085 | 40 | 235 | 12 | 1 |



ESCARIADOR DE CHAFLANES / CHAMFERBIT / EBAVUREUR Á CHANFREINS / ABSCHRÄGTIP / SBAVATORE PER SMUSSI
AFKANTINGSTIP / ESCARIADOR DE CHANFROS

| COD | | | Crestas Crests | | |
|-------|---|------|---------------------------------|-----|---|
| 63776 | CU / ACERO / PLASTICO / INOX CU / STEEL / PLASTIC / INOX | 12,4 | 3 | 100 | 6 |
| 63777 | | 25 | | 120 | |

Material: HSS (M2)



NEW

FRESA CONICA / CONIC MILLING TOOL / FRAISE CONIQUE / SCHAFTFRÄSER KONISCH / FRESA CONICA / CONISCHE
SCHACHTFREZEN / FRESA CÓNICA

| COD | | | Crestas Crests | | |
|-------|---|-------|---------------------------------|-----|---|
| 63778 | CU / ACERO / PLASTICO / INOX CU / STEEL / PLASTIC / INOX | 10-34 | 6 | 150 | 6 |

Material: HSS



NEW

ESCARIADOR CONICO / TAPER REAMER / EBAVUREUR CONIQUE / HANDREIBAHLEN / SBAVATORE CONICO / HANDTAPPEN
ESCARIADOR CÓNICO

| COD | | | Crestas Crests | | |
|-------|---|-------|---------------------------------|-----|---|
| 63779 | CU / ACERO / PLASTICO / INOX CU / STEEL / PLASTIC / INOX | 3-12 | 6 | 100 | 6 |
| 63780 | | 10-25 | 8 | 120 | |

Material: HSS



NEW

HERRAMIENTA PARA COBRE / TOOLS FOR COPPER / OUTILLAGE POUR LE CUIVRE WERKZEUGE FÜR KUPFER / UTENSILI PER RAME / GEREEDSCHAPPEN VOOR KOPER FERRAMENTAS PARA COBRE

RASQUETA / SCRAPPER / RACLOIR / ENTGRATER / SCHILDERMES / SPATOLA / ESPÁTULA

| COD | | | | | |
|-------|---|----|----|---|-------|
| 63376 | CU / ACERO / PLASTICO / INOX CU / STEEL / PLASTIC / INOX | 60 | 20 | 1 | 64449 |



| COD | | | | |
|-------|-----------------------------|-----|----|--|
| 64008 | CU / STEEL / PLASTIC / INOX | 47 | 20 | |
| 64446 | BRASS / CAST IRON | | | |
| 64447 | CU / STEEL / PLASTIC / INOX | 26 | 20 | |
| 64448 | BRASS / CAST IRON | | | |
| 64449 | CU / STEEL / PLASTIC / INOX | 120 | 20 | |



CEPILLOS PARA LIMPIEZA DE COBRE / COPPER CLEANING BRUSHES / BROSE DE NETTOYAGE POUR CUIVRE
KUPFER - REINIGUNGSBÜRSTE / SCHOONMAAKBORSTEL KOPER / SPAZZOLE PER RAME / ESCOVAS PARA LIMPIEZA DE COBRE

| COD | | | | |
|-------|-----------------------|----|---|---|
| 63206 | 1/2"-3/4" INT. / EXT. | 30 | 6 | 1 |



| COD | | | | |
|-------|------------------|----|---|---|
| 63207 | 1/2" INT. / EXT. | 10 | 6 | 1 |



| COD | | | | |
|-------|-----------|---|---|---|
| 63208 | 1/2" INT. | 5 | 6 | 1 |



CURVATUBOS / TUBE BENDERS / CINTREUSE A CUIVRE / BIEGEGERÄTE / CURVATUBI BUIGTANG

CURVATUBOS DE CARRACA / RATCHET TUBE BENDER / CINTREUSE ARBALETE / EINHAND-BIEGEGERÄT / CURVATUBI A CRICCO
BUIGTANG MET RATEL / CURVADORA DE ROQUETE

KIT

| COD | 10 | 12 | 14 | 15 | 16 | 18 | 22 | 3/8 | 1/2 | 5/8 | 3/4 | 7/8 |
|-------|----|----|----|----|----|----|----|-----|-----|-----|-----|-----|
| 68165 | | ● | | ● | | ● | ● | | | | | |
| 68166 | | ● | ● | ● | | ● | ● | | | | | |
| 68167 | | ● | ● | | ● | | ● | | | | | |
| 68168 | | ● | ● | | | ● | ● | | | | | |
| 68169 | ● | ● | | ● | | ● | ● | | | | | |
| 68170 | ● | ● | ● | ● | | ● | ● | | | | | |
| 68171 | ● | ● | ● | ● | | ● | ● | | | | | |
| 68172 | ● | ● | ● | ● | | ● | ● | | ● | ● | ● | ● |
| 68173 | ● | ● | | | | | | ● | ● | ● | ● | ● |

KIT



| COD | 1645 |
|-------|------|
| 68118 | 1645 |



| COD | O.D. |
|-------|------|
| 68128 | 8mm |
| 68129 | 10mm |
| 68130 | 12mm |
| 68131 | 14mm |
| 68132 | 15mm |
| 68133 | 16mm |
| 68134 | 18mm |
| 68135 | 22mm |

| COD | O.D. |
|-------|------|
| 68136 | 3/8" |
| 68137 | 1/2" |
| 68138 | 5/8" |
| 68139 | 3/4" |
| 68140 | 7/8" |

O.D.



KIT MULTICAPA / KIT MULTILAYER / KIT MULTICOUCHES / BIEGEGERÄFSET

| COD | 16 | 18 | 20 | 22 |
|-------|----|----|----|----|
| 68162 | ● | ● | ● | |
| 68161 | ● | ● | ● | |
| 68228 | | | | ● |
| 68227 | ● | ● | ● | ● |

KIT



COBRE
COPPER
CUIVRE



COBRE RECUBIERTO
COVERED COPPER
CUIVRE PLASTIFIE



MULTICAPA
MULTILAYER
MULTICOUCHES



MUELLES CURVATUBOS / SPRING TUBE BENDERS / RESSORT A CINTRER / KUPFERROHR-AUSSENBIEGEFEDERN
MOLLE CURVATUBI / BUIGVEREN MOLAS CURVA TUBOS

| COD | 6 | 8 | 10 | 12 | 14 | 15 | 16 | 18 | 22 | 1/4 | 3/8 | 7/16 | 1/2 | 3/4 |
|-------|-------|-------|-------|-------|-------|-------|-------|-------|-------|-------|-------|-------|-------|-----|
| 68041 | 68042 | 68043 | 68044 | 68045 | 68046 | 68047 | 68054 | 68055 | 68048 | 68049 | 68050 | 68051 | 68056 | |
| | 55 | 70 | 100 | 110 | 145 | 180 | 195 | 195 | 230 | 75 | 110 | 115 | 155 | 200 |
| | 6 | 8 | 10 | 12 | 14 | 15 | 16 | 18 | 20 | 22 | | | | |
| 68150 | 68151 | 68152 | 68153 | 68154 | 68155 | 68156 | 68157 | 68158 | 68159 | | | | | |
| | 75 | 105 | 195 | 220 | 260 | 295 | 340 | 390 | 450 | 510 | | | | |



HERRAMIENTA PARA COBRE / TOOLS FOR COPPER / OUTILLAGE POUR LE CUIVRE WERKZEUG FÜR KUPFER / UTENSILI PER RAME / GEREEDSCHAPPEN VOOR KOPER FERRAMENTAS PARA COBRE

PARA TUBO DE COBRE RECOCIDO Y ALUMINIO / FOR SOFT COPPER & ALUMINIUM TUBING
CINTREUSE POUR TUBE EN ACIER / FÜR WEICHES KUPFER UND ALUMINIUM
VOOR ZACHT KOPER EN ALUMINIUM BUIS / PER TUBIRICOTTI E ALLUMINIO
PARA TUBO DE COBRE RECOZIDO E ALUMINIO

TENAZA CURVATUBOS / TUBE BENDER / PINCE A CINTRER / ZWEIHANDBIEGER / PINZA CURVATUBI / BUIGTANG
CURVADORA PARA TUBOS

| COD | O.D. | Kg. | |
|-------|------|-----|---|
| 68144 | 10mm | 0,3 | 1 |
| 68145 | 12mm | 0,6 | |
| 68146 | 14mm | 0,9 | |
| 68147 | 15mm | 1,4 | |
| 68148 | 16mm | 1,7 | |
| 68149 | 18mm | 2,1 | |



ALUMINIO / ALUMINIUM

TENAZA CURVATUBOS DE ACERO / STEEL TUBE BENDER / PINCE A CINTRER / ZWEIHANDBIEGER / PINZA CURVATUBI
BUIGTANG / CURVADORA PARA TUBOS

| COD | O.D. | Kg. | |
|-------|------|-----|---|
| 68210 | 12mm | 1,3 | 1 |
| 68211 | 15mm | 2,7 | |
| 68213 | 22mm | 4,2 | |
| 68214 | 28mm | 8,1 | |



| COD | O.D. | Kg. | |
|-------|------|-----|---|
| 68215 | 12mm | 1,3 | 1 |
| 68216 | 15mm | 2,7 | |
| 68218 | 22mm | 4,2 | |
| 68219 | 28mm | 8,1 | |



TENAZA CURVATUBOS / TUBE BENDER / PINCE A CINTRER / ZWEIHANDBIEGER / PINZA CURVATUBI / BUIGTANG
CURVADORA PARA TUBOS

| COD | O.D. | Kg. | |
|-------|------------------|-----|---|
| 68113 | 15-22mm | 3,4 | 2 |
| 68114 | 12-15-22mm | 3,5 | |
| 68115 | 22-12-15-18-22mm | 3,7 | |
| 68116 | 15-28-22mm | 3,6 | |



| COD | O.D. |
|-------|---------|
| 81112 | 12mm |
| 81113 | 15mm |
| 81111 | 18mm |
| 81114 | 22mm |
| 81115 | 12-15mm |
| 81117 | 18mm |
| 81116 | 22mm |



| COD | O.D. | Kg. | | |
|-------|------|-------|------|---|
| 68010 | 6mm | - | 510 | 1 |
| 68011 | 8mm | 5/16" | 580 | |
| 68012 | 10mm | - | 880 | |
| 68013 | 12mm | - | 930 | |
| 68014 | 14mm | - | 1590 | |
| 68015 | 15mm | - | 1710 | |
| 68016 | 16mm | 5/8" | 2185 | |
| 68005 | - | 1/4" | 510 | |
| 68006 | - | 3/8" | 880 | |
| 68008 | - | 1/2" | 1590 | |



| COD | O.D. | | Kg. | | |
|-------|----------------------------|--------|-----|---|---|
| 68110 | 1/8-3/6-1/4" | 0-90° | 140 | 1 | 1 |
| 68111 | (1/4-5/16-3/8") (6-8-10mm) | 0-180° | 450 | | |



3x1

ABOCINADORES / FLARING TOOLS / APPAREIL A BATTRE LES COLLETS / BÖRDELGERÄTE
 FLANGIATUBI / FELSAPPARAAT / ABOCARDADORES

ABOCINADOR CONO EXCENTRICO CON CARRACA / ECCENTRIC CONE FLARING TOOL WITH RATCHET / DUDGEONNIERE EXCENTRIQUE A CLIQUET / TAUMEL-BÖRDELGERÄT MIT RATSCHEN / FLANGIATUBI CON CRICCHETTO / ECCENTRIC FELSAPPARAAT MET RATEL / ABOCARDADOR CONO EXCÉNTRICO COM ROQUETE

| COD | O.D. | 90° | Kg. | |
|-------|---|-----|------|---|
| 68096 | 1/4-5/16-3/8-1/2-5/8-3/4" | ● | 1,56 | 1 |
| 68095 | 6-8-10-12-14-15-16mm | | | |
| 68098 | 1/4-5/16-3/8-1/2-5/8-3/4" 6-8-10-12-14-15-16mm | | 2,17 | |



ABOCINADOR CONO EXCENTRICO / ECCENTRIC CONE FLARING TOOL / DUDGEONNIERE EXCENTRIQUE / TAUMEL / FLANGIATUBI CONO ECCENTRICO / ECCENTRIC FELSAPPARAAT / ABOCARDADOR CONO EXCÉNTRICO

| COD | O.D. | 90° | Kg. | |
|-------|---|-----|-----|---|
| 68087 | 1/4-5/16-3/8-1/2-5/8-3/4" | ● | 1,4 | 1 |
| 68086 | 6-8-10-12-14-15-16mm | | | |
| 68091 | 1/4-5/16-3/8-1/2-5/8-3/4" 6-8-10-12-14-15-16mm | | 2 | |



ABOCINADOR AJUSTABLE / ADJUSTABLE FLARING TOOL / DUDGEONNIERE REGLABLE / UNIVERSAL-BÖRDELGERÄT
 FLANGIATUBI REGOLABILE / VERSTELBAAR FELSAPPARAAT / ABOCARDADOR AJUSTAVEL

| COD | O.D. | 90° | Kg. | |
|-------|--------------------------|-----|-----|---|
| 68090 | 5mm-16mm 3/16" - 5/8" | ● | 810 | 1 |



ABOCINADOR DE TORRETA / COMPACT FLARING TOOL / DUDGEONNIERE COMPACTE / KOMPAKT BÖRDELGERÄT, AUFKLAPPBAR
 FLANGIATUBI A TORRETTA / KOMPAKT FELSAPPARAAT / ABOCARDADOR DE TORRETTA

| COD | O.D. | 90° | Kg. | |
|-------|----------------------------|-----|------|---|
| 68017 | 3/16-1/4-5/16-3/8-1/2-5/8" | ● | 1,05 | 1 |
| 68018 | 6-8-10-12-14mm | | | |







ABOCINADOR / FLARING TOOL / APPAREIL A BATTRE LES COLLETS / BÖRDELGERÄT / FLANGIATUBI / FELSAPPARAAT
 ABOCARDADOR

| COD | O.D. | 90° | Kg. | |
|-------|---------------------------------|-----|-----|---|
| 68001 | 3/16-1/4-5/16-3/8-7/16-1/2-5/8" | ● | 950 | 1 |
| 68003 | 4-4,75-6-8-10-12-14-15mm | | | |



EXPANDIDORES / EXPANDING TOOLS / PINCES À EMBOITURE / EXPANDER UITZETWERKTUIGEN ESPANSORI / EXPANDIDORES



EXPANKIT

| COD | O.D. |  |  |  |  | |
|-------|----------------------|---|---|---|---|-----|
| 68204 | 12-15-22-28mm | 3-32 | Ø40 | 3 | 1 | |
| 68205 | 12-14-18-22mm | | | | | |
| 68206 | 12-15-18-22mm | | | | | |
| 68207 | 1/2-5/8-3/4-1" | | | 3,1 | | |
| 68209 | 3/8-1/2-5/8-3/4-7/8" | | | | | |
| 68220 | 1/2-3/4-1" | | | 3 | | |
| 68221 | 12-14-16-18-22mm | | | - | | 2,9 |
| 68223 | 10-12-14-16-18mm | | | - | | 2,8 |
| 68224 | 12-14-16-18mm | | | - | | 2,7 |
| 68225 | 12-14-16-18-22mm | - | 2,8 | | | |







| COD |  |  |  |  |
|-------|---|---|---|---|
| 68175 | 1 | 1,3 | 1 | 1 |



| COD | O.D. | COD | O.D. |  |  |  |
|-------|------|-------|--------|---|---|---|
| 68177 | 10mm | 68190 | 3/8" | 125 | 8 | 1 |
| 68178 | 12mm | 68191 | 1/2" | 130 | | |
| 68179 | 14mm | 68192 | 5/8" | 135 | | |
| 68180 | 15mm | 68193 | 3/4" | 138 | | |
| 68181 | 16mm | 68194 | 7/8" | 140 | | |
| 68182 | 18mm | - | - | 145 | | |
| 68184 | 22mm | - | - | 150 | | |
| - | - | 68195 | 1" | 160 | | |
| 68186 | 28mm | 68196 | 1.1/8" | 270 | | |
| 68188 | 35mm | 68198 | 1.3/8" | 400 | | |
| 68189 | 42mm | - | - | 430 | | |
| - | - | 68200 | 1.5/8" | 480 | | |







SWAGING KIT

| COD | O.D. |  |  |  |  |
|-------|---|---|---|---|---|
| 68060 | 1/8-3/16-1/4-5/16-3/8-7/16-1/2-5/8-3/4" | 3/16-1/4-5/16-3/8-3/8-1/2-5/8-3/4" | 1/8-1.1/4" | 2,8 | 1 |



KIT FRIGORISTA / KIT REFRIGERATION / KIT FRIGORISTE / FRIGOKIT / FELSAPPARAAT-GECOMBINEERDE SET

| COD | O.D. |  |  |  |  |
|-------|----------------------------|---|---|---|---|
| 68052 | 4-4,75-6-8-10-12-14mm | 10-12-14-16mm | 3-32mm | 2,3 | 1 |
| 68053 | 3/16-1/4-5/16-3/8-1/2-5/8" | 5/16-3/8-1/2-5/8" | 1/8-1.1/8" | | |



PEINE PARA ALETAS 6 EN 1 / 6 IN 1 FIN COMB / PEIGNES POUR LAMES 6 EN 1 / 6 IN 1 MESSKAM / PETTINI PER ALETTE 6 IN 1 / 6 IN 1 MEETKAM / PENTES DE ALHETAS 6 EM 1

| | | | | |
|--------------|-----------------|----|---|---|
| COD | | | | |
| 63751 | 8-9-10-12-14-15 | 70 | 6 | 1 |



PEINE PARA ALETAS METALICO / STAINLESS STEEL FIN COMB / PEIGNES POUR LAMES MÉTALLIQUES / MESSKAMM ROSTFREI / PETTINI PER ALETTE IN METALLO / ROESTVRIJE MEETKAM / PENTES DE ALHETAS METALICOS

| | | |
|--------------|----|---|
| COD | | |
| 63752 | 30 | 6 |



TENAZA GRIP PINZATUBOS / PINCH OFF GRIP PLIER / PINCE ÉTAU POUR TUBES / SCHNEID GRIPZANGE / PINZA GRIP PER TUBI / SNIJ GRIPTANG / ALICATES DE GRIFE DE SELAR PARA REFRIGERAÇÃO

| | | | | |
|--------------|----|--------------|-------|---|
| COD | | | | |
| 63753 | 7" | 5/16" - 8 mm | 0,335 | 6 |



LLAVE DE CHICHARRA / RATCHET WRENCH / PINCE À CLIQUET / RATSCHENSCHLÜSSEL / CHIAVE A CRICCO / RATELSLEUTEL / CHAVES DE ROQUETE

| | | | | |
|--------------|--------------------------|---|----|---|
| COD | | | | |
| 63754 | 1/4", 3/8", 3/16", 5/16" | - | 95 | 6 |



| | | | | |
|--------------|-------------|-----|---|---|
| COD | | | | |
| 63755 | 1/4", 3/16" | 160 | 6 | 1 |



ENSANCHADORES DE GOLPE / SWAGING PUNCHES / CHASSES GOUPILLES A EMBOITURE / KLEMM DURCHSCHLAG / CALIBRATORE PER TUBI / KLEMDOORSLAG / PUNÇÕES PARA ABOCARDAR

| | | | |
|--------------|-------------------------------|-----|---|
| COD | | | |
| 63756 | 1/4", 5/16", 3/8", 1/2", 5/8" | 555 | 6 |



**HERRAMIENTA PARA COBRE / TOOLS FOR COPPER / OUTILLAGE POUR LE CUIVRE
WERKZEUG FÜR KUPFER / UTENSILI PER RAME / GEREEDSCHAPPEN VOOR KOPER
FERRAMENTAS PARA COBRE**

ENSANCHADOR DE GOLPE 3 EN 1 / 3 IN 1 SWAGING PUNCH / CHASSES GOUPILLES A EMBOITURE 3 EN 1
3 IN 1 KLEMM DURCHSCHLAG / CALIBRATORI PER TUBI 3 IN 1 / 3 IN 1 KLEMDOORSLAG / PUNÇÕES PARA ABOCARDAR 3 EM 1

| COD | O.D. | BF | | |
|-------|------------------|-----|---|---|
| 63757 | 1/2", 5/8", 7/8" | 555 | 6 | 1 |



ENSANCHADOR DE GOLPE 5 EN 1 / 5 IN 1 SWAGING PUNCH / CHASSES GOUPILLES A EMBOITURE 5 EN 1
5 IN 1 KLEMM DURCHSCHLAG / CALIBRATORI PER TUBI 5 IN 1 / 5 IN 1 KLEMDOORSLAG / PUNÇÕES PARA ABOCARDAR 5 EM 1

| COD | O.D. | BF | | |
|-------|-------------------------------|-----|---|---|
| 63758 | 1/4", 5/16", 3/8", 1/2", 5/8" | 280 | 6 | 1 |



PINZA CORTACAPILARES / CAPILLARY TUBE CUTTER / PINCE COUPE CAPILAIRES / MIKROSTRIPPER ZANGE
PINZA TAGLIACAPILLARI / MIKROSTRIPTANG / ALICATES CORTA CAPILARES

| COD | O.D. | BF | | |
|-------|--------|----|---|---|
| 63759 | 1-3 mm | 85 | 6 | 1 |



EGA *Master* S.A.

ART IN INNOVATION

La más galardonada
The most awarded
La plus primée



**PARA LAVABO / BASIN TOOLS / OUTILS LAVABO / WASCHBECKEN WERKZEUGEN
WASTAFEL GEREEDSCHAPPEN / UTENSILI PER LAVABI / FERRAMENTA PARA LAVABO**

LLAVE PARA RADIADORES / RADIATOR SPUD WRENCH / CLE DE MONTAGE / SPEZIAL RATSCHKE FÜR HEIZKÖRPER / CHIAVE DI MONTAGGIO / CHAVE DE MONTAGEM

KIT





| | | | |
|------------|----------------|---|---|
| COD | CAP |  |  |
| 61167 | 3/8-1/2-3/4-1" | 490 | 1 |

| | |
|------------|---|
| COD |  |
| 61168 | |

| | |
|------------|---|
| COD |  |
| 61169 | |



TENAZA DE SIFON / SYPHON PLIER / PINCE SANIGRIP / SANIGRIP / PINZA PER SIFONI / SYPHON TANG / ALICATE DE SIFAO

| | | | | | |
|------------|---|---|---|---|---|
| COD |  |  |  |  |  |
| 62136 | 62 | 10" | 305 | 6 | 1 |



**KIT REPARADOR DE GRIFOS / VALVE RESEATER / KIT PLOMBER / WASSERHAHN-FRÄSGERÄT / KIT APPARECHI PER RUBINETTI
KRAANZITTINGSLIJPER SET / KIT REPARADOR DE TORNEIRAS**

| | | | |
|------------|---|---|---|
| COD |  |  |  |
| 68059 | 10-12-13-14-15-16 | 380 | 1 |



**KIT REPARADOR DE GRIFOS / VALVE RESEATER / KIT PLOMBER / WASSERHAHN-FRÄSGERÄT / KIT APPARECHI PER RUBINETTI
KRAANZITTINGSLIJPER SET / KIT REPARADOR DE TORNEIRAS**

| | | | |
|------------|---|---|---|
| COD |  |  |  |
| 68058 | 10-12-13-14-15-16 | 405 | 1 |



PARA LAVABO / BASIN TOOLS / OUTILS LAVABO / SANITÄR - WERKZEUG WASTAFEL GEREEDSCHAPPEN / UTENSILI PER LAVABI / FERRAMENTA PARA LAVABO

LLAVES DE LAVABO / BASIN WRENCHES / CLES LAVABO / STANDHAHNMUTTERNNSCHLÜSSEL / CHIAVI PER LAVABI
TAFELMOERTANG / CHAVES DE LAVABO

STANDARD

| COD | | | | | |
|-------|-------|-----|-----|---|---|
| 61008 | 10÷32 | 288 | 490 | 6 | 1 |



TELESCOPIC

| COD | | | | | |
|-------|-------|-----|-----|---|---|
| 61009 | 10÷32 | 460 | 700 | 6 | 1 |



| COD | | | | | |
|-------|-------|-----|-----|---|---|
| 61000 | 15÷32 | 240 | 495 | 6 | 1 |



| COD | | | | | |
|-------|-----------|-----|-----|---|---|
| 61325 | 1"÷1.1/4" | 240 | 305 | 6 | 1 |



NIVEL PARA LAVABOS / PLUMBERS BASIN LEVEL / DIMA REGOLABILE PER LAVABO / NORMABSTANDSWASSERWAAGE SANITÄR
NORMAFSTANDWATERPAS / NIVEAU LAVABO

| COD | | | mm/m | CAP | | | |
|-------|--------|-----|------|------|-----|---|---|
| 65780 | 90÷220 | 300 | 0,5 | 1/2" | 400 | 6 | 1 |





1 Excelente resistencia a altas temperaturas llegando incluso hasta 1750°C.
 Excellent resistance to high temperatures, reaching even 1750°C.
 Excellente résistance aux hautes températures, supportant jusqu'à 1750°C.

2 El regulador de gas permite modificar las dimensiones de la llama.
 The gas regulator allows the adjustment of the flame dimensions.
 Le régulateur de gaz permet la variation des flammes.

3 Auto-encendido piezoléctrico para evitar el uso de agentes externos.
 Piezoelectric self-ignition to avoid using external agents.
 Auto-allumage piézoélectrique pour éviter l'utilisation d'agents extérieurs.

4 Disponible para cartuchos estándar con rosca 7/16".
 Available for standard cartridges with 7/16" thread.
 Disponible pour des cartouches standards avec filetage de 7/16".

5 Agarre ergonómico para un uso cómodo y eficaz.
 Ergonomic handle for a comfortable and effective use.
 Prise ergonomique pour une utilisation commode et efficace.



Ega Master es el fabricante con mayor variedad de sopletes, con boquillas desde Ø25mm hasta Ø76mm, y mangueras con longitudes desde 2 hasta 10m.

Ega Master is the maker with the widest range of torches, with tips from Ø25mm to Ø76mm, and hoses with lengths from 2 to 10m.

Ega Master est le fabricant ayant la plus grande variété de torches, avec des buses de 25 mm à 76 mm, et de tuyaux de 2 à 10 m de long.



Con abundantes modelos de sopletes con encendido piezoléctrico para adaptarse a los distintos tipos de uso.

Several models of torches with piezoelectric ignition for all different professional uses.

Avec d'abondants modèles de torches dotés d'un allumage piézoélectrique pour tout type d'usage.



Existen diversas soluciones para trabajos en los que no sea posible el acceso de bombonas.

There are several solutions for jobs in which the use of gas cylinders is not possible

Il existe plusieurs solutions de travail pour les accès impossibles avec des bombones.





16

SOLDADURA / SOLDERING / SOUDURE / LÖTEN / SALDATURA / SOLDEREN SOLDADURA





CANDILEJA / BLOWLAMP / TORCHE / BUTANGAS-LÖTBRENNER / LAMPADA PER SILDARE / SOLDEERBRANDER / SOPRADOR

| COD | |  |  |  |
|-------|-------|---|---|---|
| 63219 | Piezo | | 775 | 1 |

Tmáx = 1750 °C



SOLDADOR DE ESTAÑO / SOLDERING / SOUDAGE A L'ETAIN / LOTKOLBEN / TIN SOLDEERBOUT
DE SOLDAR A ESTANHO



| COD | |  |  | Blister |
|-------|--|---|---|---------|
| 63235 | | 310 | 6 | 1 |

Tmáx = 1450 °C





SOPLETES / TORCH / TORCHE / BRENNER / TORCIA / BRANDER / MAÇARICOS

SOPLETES PIEZOELÉCTRICOS / PIEZOELECTRIC TORCHES / TORCHES PIEZOELECTRIQUES / ELEKTRISCHES LÖTGERÄT /
ELECTRISCHE SOLDEERBOUT / MAÇARICOS ELÉCTRICOS

| COD | |  |  |  | Blister |
|-------|-------|---|---|---|---------|
| 63232 | Piezo | 7/16" | 320 | 6 | 1 |



Tmáx = 1750 °C



| COD | |  |  |  | Blister |
|-------|-------|---|---|---|---------|
| 63233 | Piezo | 7/16" | 215 | 6 | 1 |

Tmáx = 1450 °C







| COD | |  |  |  | Blister |
|-------|-------|---|---|---|---------|
| 63234 | Piezo | 7/16" | 165 | 6 | 1 |



SOPLETES / TORCH / TORCHE / BRENNER / TORCIA / BRANDER / MAÇARICOS

SOPLETES TIPO EUROPEO / EUROPEAN TYPE TORCHES / TORCHE TYPE EUROPÉEN / BRENNER TYP EUROPA / TORCIA TIPO EUROPEO / BRANDER TYPE EUROPE / MAÇARICOS TIPO EUROPEU

| COD |  mm |  L mm |  |  gr. |  |
|--------------|--|--|---|---|--|
| 63220 | 25 | 310 | 2 m | 590 | 1 |

Tmáx = 2400 °C



| COD |  mm |  L mm |  |  gr. |  |
|--------------|--|--|---|---|--|
| 63221 | 35 | 400 | 2 m | 630 | 1 |



Tmáx = 2400 °C



| COD |  mm |  L mm |  |  gr. |  |
|--------------|---|--|--|---|--|
| 63222 | 45 | 400 | 2 m | 685 | 1 |





Tmáx = 2400 °C



| COD |  mm |  L mm |  |  gr. |  |
|--------------|--|--|---|---|--|
| 63223 | 50 | 400 | 2 m | 790 | 1 |





Tmáx = 2400 °C



| COD |  mm |  L mm |  |  gr. |  |
|--------------|--|--|---|---|--|
| 63224 | 60 | 580 | 5 m | 920 | 1 |
| 63226 | | 700 | | 990 | |

Tmáx = 2400 °C



| COD |  mm |  L mm |  |  gr. |  |
|--------------|--|--|---|---|--|
| 63225 | 76 | 580 | 5 m | 950 | 1 |
| 63227 | | 700 | 10 m | 1000 | |
| 63228 | | 1000 | | 1050 | |

Tmáx = 2400 °C



ACCESORIOS / SPARE PARTS / RECHANGES / ERSATZTEILE / ACCESSORI / TOEBEHOREN / ACESSORIOS

| COD | mm | L mm | gr. | |
|-------|----|------|-----|---|
| 63236 | 25 | 62 | 70 | 1 |
| 63237 | 35 | 80 | 100 | |
| 63238 | 45 | 92 | 150 | |
| 63239 | 50 | 103 | 205 | |
| 63240 | 60 | 117 | 300 | |
| 63241 | 76 | 120 | 355 | |

| COD | L mm | gr. | |
|-------|------|-----|---|
| 63242 | 200 | 200 | 1 |



SOPLETES TIPO AMERICANO / AMERICAN TYPE TORCHES / TORCHE TYPE AMÉRICAIN / BRENNER TYP AMERICA
TORCIA TIPO AMERICANO / BRANDER TYPE AMERIKA / MAÇARICOS TIPO AMERICANO

| COD | mm | L mm | | gr. | |
|-------|----|------|-----|-----|---|
| 63229 | 30 | 385 | 2 m | 650 | 1 |

Tmáx = 2400 °C



| COD | mm | L mm | | gr. | |
|-------|----|------|-----|-----|---|
| 63230 | 35 | 520 | 2 m | 780 | 1 |

Tmáx = 2400 °C



| COD | mm | L mm | | gr. | |
|-------|----|------|-----|-----|---|
| 63231 | 50 | 710 | 5 m | 850 | 1 |

Tmáx = 2400 °C

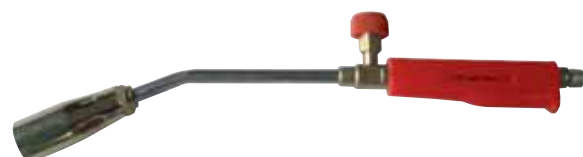

ESCUADRA MAGNETICA PARA SOLDADURA / MAGNETIC WELDING SQUARE / EQUERRE MAGNETIQUE POUR SOUDURE
MAGNETISCHE SCHWEISSWINKELHAKEN / SQUADRA MAGNETICA PER SOLDATORI / MAGNETISCHE LASWINKELHAKEN
ESQUADRO MAGNÉTICO PARA SOLDADURA

| COD | A | B | C | Grosor Thickness (mm) | Kg |
|-------|----|----|-----|-----------------------|-----|
| 65766 | 85 | 85 | 120 | 15 | 0,5 |

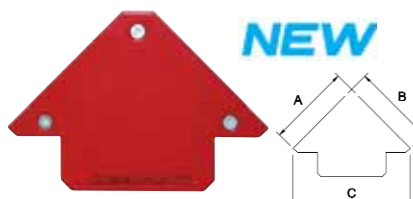

CEPILLOS / BRUSHES / PINCEAUX / BÜRSTE / SPAZZOLE / BORSTEL / ESCOVAS

CEPILLO UNIVERSAL / UNIVERSAL BRUSH / PINCEAU UNIVERSEL / UNIVERSALE BRÜSTE / SPAZZOLE UNIVERSALI / UNIVERSELE BORSTEL / ESCOVA UNIVERSAL

| COD | Material | mm | gr. |
|-------|------------------------------------|-----|-------|
| 61577 | Acero inoxidable / Stainless Steel | 250 | 3 100 |



| COD | Material | mm | gr. |
|-------|--------------------------------|-----|-------|
| 61578 | Acero latonado / Brassed Steel | 250 | 3 100 |
| 61576 | Latón / Brass | | |



CEPILLO SOLDADURA / SOLDERING BRUSH / PINCEAU DE SOUDURE / LÖTBÜRSTE / SPAZZOLE PER SALDATORI / SOLDEERBORSTEL / ESCOVA SOLDADURA

| COD | Nº Filas Rows | Material | mm | gr. |
|-------|---------------|-------------------------------------|-----|-----|
| 61570 | 3 | Acero inoxidable Stainless Steel | 290 | 3 |
| 61571 | 4 | | | |
| 61572 | 5 | | | |
| 61573 | 3 | Acero latonado Brassed Steel | 290 | 3 |
| 61574 | 4 | | | |
| 61575 | 5 | | | |



CEPILLO SOLDADURA CON MANGO DE PLASTICO / PLASTIC HANDLE SOLDERING BRUSH / PINCEAU DE SOUDURE AVEC MANCHE PLASTIQUE / LÖTHRÜSTE MIT KUNSTSTOFF GRIFF / SPAZZOLE PER SALDATORI CON MANICO IN PLASTICA / SOLDEERBORSTEL MET KUNSTSTOF HANDGRIEP / ESCOVA SOLDADURA COM CABO PLÁSTICO

| COD | Nº Filas Rows | Material | mm | gr. |
|-------|---------------|-------------------------------------|-----|-------|
| 61579 | 4 | Acero inoxidable Stainless Steel | 240 | 3 150 |



| COD | Nº Filas Rows | Material | mm | gr. |
|-------|---------------|---------------------------------|-----|-------|
| 61580 | 4 | Acero latonado Brassed Steel | 240 | 3 150 |





*HERRAMIENTA PARA PLÁSTICO / TOOLS FOR PLASTIC / OUTILLAGE POUR
LE PLASTIQUE / WERKZEUG FÜR PLASTIK / UTENSILI PER PLASTICA
GEREEDSCHAPPENVOOR PLASTIEK / FERRAMENTAS PARA PLÁSTICO*



Medalla de Plata, Salon Internacional de la Invención, París 2004
 Silver Medal, International Inventors Competition, Paris 2004
 Médaille d'Argent, Salon International de L'Invention, Paris 2004

El especial diseño patentado de cuchilla y la geometría precisa del ángulo de ataque hacen del cortatubos Piraina de EGA Master el más versátil para cortar tubos de PE, PP, PB, VPE, PVDF e incluso de PVC rígido sin riesgo a que el tubo se fracture en pedazos.

The special patented design of the blade and the accurate geometry of the attack angle, make the EGA Master Piraina® plastic pipe cutter the most versatile tool to cut PE, PP, PB, VPE, PVDF pipes, even rigid PVC pipes, without risk of pipe breaking.

Le dessin original breveté de la lame et la géométrie précise de l'angle d'attaque, font du coupe tube PIRAINA de EGAMASTER, l'outil le plus versatile pour couper des tubes en PE,PP,PB,VPE,PVDF et aussi le PVC rigide, sans risque de le fendre ou de le casser.

El único cortatubos que puede cortar además tubos de Kevlar (SAE 100 R8).

The only pipe cutter also able to cut Kevlar pipes (SAE 100 R8).

L'unique coupe tubes capable de couper des tubes en Kevlar (SAE 100 R8) aussie.



Esencial para profesionales con las más altas exigencias.

Essential for demanding professionals.

Essentiel pour les professionnels les plus exigeants.

Por todo ello fue merecedor de la MEDALLA DE PLATA en el Salón Internacional de la Invención, Concours Lépine, Paris Mayo 2004.
 Due to these reasons, it won the Silver Medal in the prestigious International Inventors Competition in Paris, May 2004.

Pour ces raisons, il fut récompensé de la médaille d'argent, au salon International de l'innovation, concours Lépine, Paris Mai 2004.



Geometría de precisión
 Precise geometry
 Géométrie de précision



KEVLAR



PVC rígido
 rigid PVC
 PVC rigide

CORTATUBOS PARA TUBO DE PLASTICO / PLASTIC PIPE CUTTER / COUPE-TUBE PLASTIQUE / KUNSTSTOFFROHR-SCHEREN / CESOIA PER TUBI DI PLASTICA / PIJPSNIJDER VOOR PLASTIEKBUIS / TESOURA PARA TUBO DE PLASTICO

PIRAINA®

| COD | O.D. | Wt. | Wt. | Wt. | Wt. |
|--------|------|-----|-----|-----|-------|
| 63205* | 42 | 550 | 5 | 1 | 64045 |
| 63204* | | | | | 64039 |



*63205: KEVLAR, PVC, PE, PP, PB, VPE, PVDF, MLP, HTA, PPR.
*63204: PVC, PE, PP, PB, VPE, PVDF, MLP, HTA, PPR.



STANDARD

| COD | O.D. | Wt. | Wt. | Wt. | Wt. |
|--------|------|-----|-----|-----|-------|
| 63200* | 42 | 305 | 6 | 1 | 64003 |



*63200: PE, PP, PB, VPE, PVDF, MLP, PPR.



| COD | O.D. | Wt. | Wt. | Wt. | Wt. |
|--------|------|------|-----|-----|-------|
| 63203* | 63 | 1175 | 6 | 1 | 64107 |



*63203: PE, PP, PB, VPE, PVDF, MLP, PPR



CORTATUBOS AUTOMATICO PARA TUBO DE PLASTICO / AUTOMATIC PLASTIC PIPE CUTTER / COUPE-TUBE PLASTIQUE AUTOMATIQUE / KUNSTSTOFFROHR-SCHEREN AUTOMATIK / TAGLIATUBI AUTOMATICO PER TUBI DI PLASTICA / PIJPSNIJDER VOOR PLASTIEKBUIS-AUTOMATISCH / CORTA TUBOS DE PLASTICO

| COD | O.D. | Wt. | Wt. | Wt. | Wt. |
|--------|------|-----|-----|-----|-------|
| 63202* | 42 | 690 | 6 | 1 | 64034 |



*63202: KEVLAR, PVC, PE, PP, PB, VPE, PVDF, MLP, HTA, PPR.



| COD | O.D. | Wt. | Wt. | Wt. | Wt. |
|--------|------|-----|-----|-----|-------|
| 63201* | 35 | 570 | 6 | 1 | 64004 |



*63201: KEVLAR, PVC, PE, PP, PB, VPE, PVDF, MLP, HTA, PPR.



HERRAMIENTA PARA PLÁSTICO / TOOLS FOR PLASTIC / OUTILLAGE POUR LE PLASTIQUE / WERKZEUG FÜR PLASTIK / UTENSILI PER PLASTICA GEREEDSCHAPPENVOOR PLASTIEK / FERRAMENTAS PARA PLÁSTICO

UNIQUE 42

| COD | MAT. | O.D. | GF | | | | |
|-------|---------|------|-----|---|---|-------|----|
| 63120 | PLASTIC | 42 | 575 | 8 | 1 | 63112 | 10 |



UNIQUE 45

| COD | MAT. | O.D. | GF | | | | |
|-------|---------|------|-----|---|---|-------|----|
| 63189 | PLASTIC | 45 | 610 | 8 | 1 | 63112 | 10 |



AUTOMATIC 50

| COD | MAT. | O.D. | GF | | | | |
|-------|---------|------|-----|---|---|-------|----|
| 63365 | PLASTIC | 50 | 450 | 8 | 1 | 63722 | 10 |



AUTOMATIC 67

| COD | MAT. | O.D. | GF | | | | |
|-------|---------|------|-----|---|---|-------|----|
| 63108 | PLASTIC | 67 | 750 | 6 | 1 | 63112 | 10 |



AUTOMATIC 127

| COD | MAT. | O.D. | GF | | | | |
|-------|---------|--------|------|---|---|-------|----|
| 63173 | PLASTIC | 50-125 | 1950 | 1 | 1 | 64105 | 10 |



SIERRA PARA PVC/ABS / PVC/ABS CUTTING SAW / SCIE A PVC / PVC/ABS SÄGE / SEGHEtto PER PVC/ABS / PVC/ABS ZAGEN
SERRA PARA PLÁSTICO

| COD | L | A | B | inch | GF | |
|-------|-----|---|-----------|------|-----|---|
| 63379 | 395 | | 12" (300) | 18 | 300 | 6 |
| 64458 | | | | | | |
| 64459 | | | | | | |

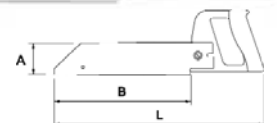

SOLDADOR TUBO DE PLASTICO / PLASTIC PIPE WELDER / APPAREIL A SOUDER HEIZELEMENT-MUFFENSCHWEISSGERATÉ / POLIFUSORE

SOLDAMATIC DIGITAL 800

| COD | mm | W | V | Kg. | |
|-------|---------|-----|-----|-----|---|
| 62884 | 20 ~ 63 | 800 | 110 | 1,8 | 1 |
| 62885 | | | 230 | | |

Temperatura de trabajo / Working temperature / Température de travail: 200 ~ 280°C

PE, PP, PB, PVDF, PPR



SOLDAMATIC DIGITAL 800 (con vasos / with sockets / avec douille)

| COD | mm | Vasos incluidos / Included Sockets | W | V | Kg. | |
|-------|---------|------------------------------------|-----|-----|-----|---|
| 62886 | 20 ~ 63 | 20-25-32 | 800 | 110 | 2,4 | 1 |
| 62887 | | | | 230 | | |

Temperatura de trabajo / Working temperature / Température de travail: 200 ~ 280°C

PE, PP, PB, PVDF, PPR



| COD | mm | Kg. | |
|-------|-----|------|---|
| 62892 | 20 | 75 | 1 |
| 62893 | 25 | 115 | |
| 62894 | 32 | 175 | |
| 62895 | 40 | 370 | |
| 62896 | 50 | 420 | |
| 62897 | 63 | 575 | |
| 62898 | 75 | 400 | |
| 62899 | 90 | 600 | |
| 62900 | 110 | 1000 | |
| 62901 | 125 | 1300 | |



HERRAMIENTA PARA PLÁSTICO / TOOLS FOR PLASTIC / OUTILLAGE POUR LE PLASTIQUE / WERKZEUGE FÜR PLASTIK / UTENSILI PER PLASTICA GEREEDSCHAPPENVOOR PLASTIEK / FERRAMENTAS PARA PLÁSTICO

SOLDADOR TUBO DE PLASTICO / PLASTIC PIPE WELDER / APPAREIL A SOUDER HEIZELEMENT-MUFFENSCHWEISSGERATÉ / POLIFUSORE

SOLDAMATIC DIGITAL 1200

| COD | mm | W | V | Kg | |
|-------|----------|------|-----|-----|---|
| 62888 | 20 ~ 110 | 1200 | 110 | 2,5 | 1 |
| 62889 | | | 230 | | |

Temperatura de trabajo / Working temperature / Température de travail: 200 ~ 280°C



PE, PP, PB, PVDF, PPR



SOLDAMATIC DIGITAL 1200 (con vasos / with sockets / avec douille)

| COD | mm | Vasos incluidos Included Sockets | W | V | Kg | |
|-------|----------|-------------------------------------|------|-----|----|---|
| 62890 | 20 ~ 125 | 75-90-110 | 1200 | 110 | 5 | 1 |
| 62891 | | | | 230 | | |

Temperatura de trabajo / Working temperature / Température de travail: 200 ~ 280°C



PE, PP, PB, PVDF, PPR



| COD | mm | W | |
|-------|-----|------|---|
| 62892 | 20 | 75 | 1 |
| 62893 | 25 | 115 | |
| 62894 | 32 | 175 | |
| 62895 | 40 | 370 | |
| 62896 | 50 | 420 | |
| 62897 | 63 | 575 | |
| 62898 | 75 | 400 | |
| 62899 | 90 | 600 | |
| 62900 | 110 | 1000 | |
| 62901 | 125 | 1300 | |









**HERRAMIENTA PARA MADERA / TOOLS FOR WOOD / OUTILLAGE POUR LE BOIS
WERKZEUGE FÜR HOLZ / UTENSILI PER LEGNO / GEREEDSCHAPPEN VOOR HOUT
FERRAMENTAS PARA MADEIRA**

FORMONES / FIRMER CHISELS / CISEAUX A BOIS / STECHBEITEL / SCALPELLI
 STEEKBEITELS / FORMOES





Hoja de acero especial, rectificada / Precision machined steel blade / En acier special trempé et poli
 Stechbeitel aus spezialstahl, präzisionsgeschliffen / Lama-inacciaio speciale rettificata / Sttekbeitel-precisie geslepen
 Lâmina de aço especial rectificada

| COD |  |  |  |  |
|-------|---|---|---|---|
| 67132 | 6 | 130 | | |
| 67133 | 8 | 135 | | |
| 67134 | 10 | 140 | | |
| 67135 | 12 | 145 | | |
| 67165 | 14 | 150 | | |
| 67136 | 15 | 155 | | |
| 67166 | 16 | 160 | 12 | 1 |
| 67137 | 18 | 170 | | |
| 67138 | 20 | 175 | | |
| 67139 | 22 | 180 | | |
| 67140 | 25 | 190 | | |
| 67141 | 30 | 205 | | |
| 67142 | 32 | 215 | | |
| 67143 | 35 | 225 | | |

DIN 5139

TITACROM® B.M.A.T







| COD |  |  |  |  |
|-------|---|---|---|---|
| 67150 | 6 | 130 | | |
| 67151 | 8 | 135 | | |
| 67152 | 10 | 140 | | |
| 67153 | 12 | 145 | | |
| 67154 | 14 | 150 | | |
| 67155 | 15 | 155 | | |
| 67156 | 16 | 160 | | |
| 67157 | 18 | 170 | 12 | 1 |
| 67158 | 20 | 175 | | |
| 67159 | 22 | 180 | | |
| 67160 | 25 | 190 | | |
| 67161 | 30 | 205 | | |
| 67162 | 32 | 215 | | |
| 67163 | 35 | 225 | | |

DIN 5139

TITACROM® B.M.A.T







| COD |  |  |  |  |
|-------|---|---|---|---|
| 67169 | 6 | 130 | | |
| 67170 | 8 | 135 | | |
| 67171 | 10 | 140 | | |
| 67172 | 12 | 145 | | |
| 67173 | 14 | 150 | | |
| 67174 | 15 | 155 | | |
| 67175 | 16 | 160 | | |
| 67176 | 18 | 170 | 12 | 1 |
| 67177 | 20 | 175 | | |
| 67178 | 22 | 180 | | |
| 67179 | 25 | 190 | | |
| 67180 | 30 | 205 | | |
| 67181 | 32 | 215 | | |
| 67182 | 35 | 225 | | |

DIN 5139

TITACROM® B.M.A.T



| COD |  |  |  |  |
|-------|---|---|---|---|
| 67065 | 6 | 130 | | |
| 67066 | 8 | 135 | | |
| 67067 | 10 | 140 | | |
| 67068 | 12 | 145 | | |
| 67069 | 14 | 150 | | |
| 67070 | 15 | 155 | | |
| 67071 | 16 | 160 | | |
| 67072 | 18 | 170 | 12 | 1 |
| 67073 | 20 | 175 | | |
| 67074 | 22 | 180 | | |
| 67075 | 25 | 190 | | |
| 67076 | 30 | 205 | | |
| 67077 | 32 | 215 | | |
| 67078 | 35 | 225 | | |

DIN 5139



**EXPOSITORES / DISPLAYS / PRESENTOIRS / VERKAUFSSTÄNDER / ESPOSITORE
DISPLAY STAND**

TITACROM BIMAT 50 PCS.

PCS. **COD:69483**

| | |
|---|------|
| 5 | 6mm |
| 5 | 8mm |
| 5 | 10mm |
| 5 | 12mm |
| 5 | 15mm |
| 5 | 18mm |
| 5 | 20mm |
| 5 | 22mm |
| 5 | 25mm |
| 5 | 30mm |



**PRESENTADOR INDIVIDUAL / INDIVIDUAL DISPLAY / CONDITIONNEMENT UNITAIRE
EINZELPACKUNG**



kits

TITACROM BIMAT 4 PCS.

PCS. **COD:69480**

| | | |
|---|--------------|------|
| 1 | 67134 | 10mm |
| 1 | 64135 | 12mm |
| 1 | 67136 | 15mm |
| 1 | 67137 | 18mm |



TITACROM BIMAT 4 PCS.

PCS. **COD:69409**

| | | |
|---|--------------|------|
| 1 | 67152 | 10mm |
| 1 | 67153 | 12mm |
| 1 | 67155 | 15mm |
| 1 | 67157 | 18mm |



TITACROM BIMAT 4 PCS.

PCS. **COD:69481**

| | | |
|---|--------------|------|
| 1 | 67171 | 10mm |
| 1 | 67172 | 12mm |
| 1 | 67174 | 15mm |
| 1 | 67176 | 18mm |



4 PCS.

PCS. **COD:69482**

| | | |
|---|--------------|------|
| 1 | 67067 | 10mm |
| 1 | 67068 | 12mm |
| 1 | 67070 | 15mm |
| 1 | 67072 | 18mm |



HERRAMIENTA PARA MADERA / TOOLS FOR WOOD / OUTILLAGE POUR LE BOIS WERKZEUG FÜR HOLZ / UTENSILI PER LEGNO / GEREEDSCHAPPEN VOOR HOUT FERRAMENTAS PARA MADEIRA

CEPILLOS / JACK PLANES / RABOTS / SCHLICHTHOBEL / PIALLA / SCHAAF / PLAINAS

| COD | L | GF | | |
|-------|-----|-----|---|-------|
| 67051 | 250 | 1,5 | 1 | 64239 |
| 67052 | 350 | 2 | | |



SARGENTOS / CLAMPS / SERRE-JOINTS / ZWINGEN / MORSETTI SERRAGIUNTI / KLEMMEN / GRAMPOS

MOD. G

| COD | A MAX mm | B mm | GF | | |
|-------|----------|------|------|---|--|
| 69570 | 50 | 30 | 450 | 6 | |
| 69571 | 75 | 52 | 600 | | |
| 69572 | 100 | 60 | 800 | | |
| 69574 | 150 | 75 | 1200 | 3 | |
| 69575 | 200 | 83 | 1650 | | |



MOD. F

| COD | A MAX mm | B mm | GF | | | | |
|-------|----------|------|------|---|--|---|--|
| 69580 | 150 | 50 | 450 | 6 | | | |
| 69581 | 200 | | 600 | | | | |
| 69582 | 250 | 80 | 1000 | | | | |
| 69583 | 300 | | 1150 | | | | |
| 69584 | 300 | 120 | 1300 | | | 2 | |
| 69585 | 400 | | 1600 | | | | |
| 69586 | 400 | | 1800 | | | | |
| 69587 | 500 | | 2000 | | | | |
| 69588 | 600 | 2200 | | | | | |
| 69589 | 800 | 2700 | | | | | |
| 69590 | 1000 | 3000 | | | | | |

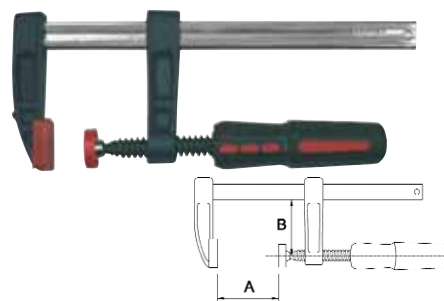

TORNILLO DE APRIETE DE ÉMBOLO / PUMP TYP CLAMP / ZWINGE PUMPE TYP / MORSÀ A PISTONE / POMPKLEM / TORNO DE APERTO DE ÊMBOLO

| COD | A MAX mm | B mm | GF | | |
|-------|----------|------|------|---|--|
| 69992 | 200 | 120 | 1800 | 6 | |
| 69993 | 250 | | 1900 | | |
| 69994 | 300 | | 2050 | | |
| 69995 | 400 | | 2150 | | |
| 69996 | 500 | | 2300 | | |
| 69997 | 600 | 2500 | 2 | | |
| 69998 | 800 | 3100 | | | |
| 69999 | 1000 | 3500 | | | |

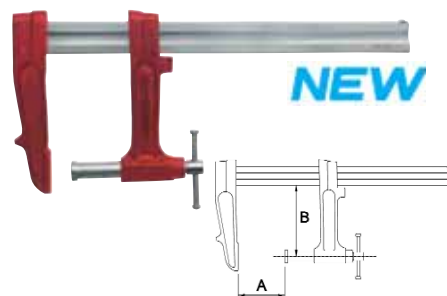

FORJADO / FORGED / FORGÉ / GESCHMIEDET / FORGIATO / GESMEED / FORJADO

| COD | A MAX mm | B mm | C mm | D mm | GF | |
|-------|----------|------|------|------|------|---|
| 69959 | 160 | 80 | 7,5 | 15,5 | 600 | 6 |
| 69960 | 200 | | | | 640 | |
| 69961 | 250 | | | | 700 | |
| 69962 | 300 | | | | 750 | |
| 69963 | 400 | | | | 800 | |
| 69964 | 200 | | | | 100 | |
| 69965 | 250 | 950 | | | | |
| 69966 | 300 | 1000 | | | | |
| 69967 | 400 | 800 | | | | |
| 69968 | 500 | 120 | 10,5 | 21,5 | 900 | 2 |
| 69969 | 200 | | | | 1100 | |
| 69970 | 250 | | | | 1300 | |
| 69971 | 300 | | | | 1400 | |
| 69972 | 400 | | | | 1600 | |
| 69973 | 500 | | | | 1800 | |
| 69974 | 600 | | | | 2000 | |
| 69975 | 800 | | | | 2200 | |
| 69976 | 1000 | | | | | |
| 69977 | 1200 | | | | | |

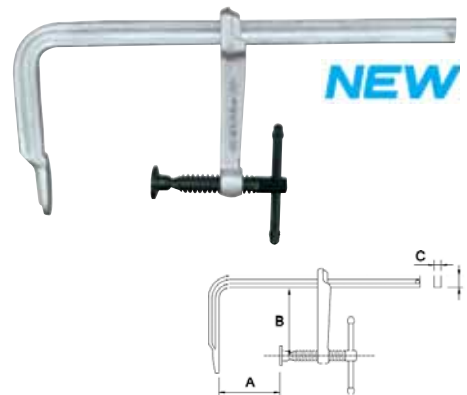



CORTAVARILLAS

BOLT CUTTERS

COUPES-BOULONS

Los cortavarillas Ega Master están perfectamente diseñados y fabricados para cortar varillas cilíndricas, varillas de encofrador, mallas de alambre, cables, pernos, etc.

Ega Master bolt cutters are perfectly designed and manufactured for cutting rod, bolts, concrete from ties, cable and wires.

Les coupes-boulons Egamaster sont parfaitement conçus et fabriqués pour la coupe des tiges, des boulons, des câbles et des fils.



1 Sistema multiplicador de par de corte.
Cutting leverage multiplying system.
Accroissement de la coupe par le système multiplicateur.

3 Gran capacidad de corte
Great cutting capacity
Capacité de coupe très importante.

4 Mangos ergonómicos y confortables.
Ergonomic and comfortable handles.
Poignées ergonomiques et confortables.

2 El diseño especial reforzado de cabeza permite cortar varillas, pernos, etc. a muy poca distancia de la superficie desde la que sobresalen. El juego de cuchillas están fabricadas en cromo-molibdeno, dándole una mayor resistencia y durabilidad gracias a la dureza 62 HRC.

Its strong & specially designed head permits cutting bolts and rods at a very small distance from the surface where they stick out from. Cutting-blades are made in Chrome-Molibdenum, providing a bigger resistance and durability due to their 62 HRC hardness.

Les lames sont fortes et particulièrement conçues pour couper des boulons et sont tiges à une distance très petite de la surface. Les lames de coupe sont faites en Chrome-Molibdenum, fournissant une plus grande résistance et longévité due à leur dureté de 62 HRC.

CORTAVARILLAS / BOLT CUTTERS / COUPE-BOULONS / BOLZENSCHNEIDER / TAGLIABULLONI
BOUTENSCHAREN / CORTA VARÃO

A

COD ← L → ← A → ← B → ← C →

| COD | L | A | B | C | 55Kg/mm ² / 145Kg/mm ² | Kg. | |
|-------|-----|-----|----|------|--|-----|---|
| 62193 | 14" | 60 | 26 | 7 | 7-5 | 1,1 | 1 |
| 62194 | 18" | 70 | 29 | 8 | 8-6 | 1,5 | |
| 62195 | 24" | 85 | 33 | 9,6 | 10-8 | 2,4 | |
| 62196 | 30" | 97 | 36 | 11,3 | 13-10 | 3,7 | |
| 62197 | 36" | 109 | 39 | 13 | 16-12 | 5,8 | |
| 62198 | 42" | 120 | 43 | 14 | 19-14 | 8,2 | |
| 62199 | 48" | 155 | 60 | 17 | 22-16 | 14 | |

B

COD ← L → ← A → ← B → ← C →

| COD | L | A | B | C | 55Kg/mm ² / 145Kg/mm ² | Kg. | |
|-------|-----|-----|----|------|--|-----|---|
| 62201 | 14" | 60 | 26 | 7 | 7-5 | 1,1 | 1 |
| 62202 | 18" | 70 | 29 | 8 | 8-6 | 1,5 | |
| 62203 | 24" | 85 | 33 | 9,6 | 10-8 | 2,4 | |
| 62204 | 30" | 97 | 36 | 11,3 | 13-10 | 3,7 | |
| 62205 | 36" | 109 | 39 | 13 | 16-12 | 5,8 | |
| 62206 | 42" | 120 | 43 | 14 | 19-14 | 8,2 | |

| A | B | L |
|-------|-------|-----|
| 64096 | 64056 | 14" |
| 64097 | 64057 | 18" |
| 64098 | 64058 | 24" |
| 64099 | 64059 | 30" |
| 64100 | 64060 | 36" |
| 64101 | 64061 | 42" |

KIT 9 PCS. -COD. A-
PCS. **COD:62191**

| | | |
|---|-------|-----|
| 2 | 62193 | 14" |
| 2 | 62194 | 18" |
| 2 | 62195 | 24" |
| 2 | 62196 | 30" |
| 1 | 62197 | 36" |

KIT 9 PCS. -COD. B-
PCS. **COD:62190**

| | | |
|---|-------|-----|
| 2 | 62201 | 14" |
| 2 | 62202 | 18" |
| 2 | 62203 | 24" |
| 2 | 62204 | 30" |
| 1 | 62205 | 36" |



CORTAVARILLAS / BOLT CUTTERS / COUPE-BOULONS / BOLZENSCHNEIDER / TAGLIABULLONI
BOUTENSCHAREN / CORTA VARÃO

MANGOS FORJADOS / FORGED HANDLES / MANCHES FORGÉS / STAHL GESCHMIEDET / MANICI FORGIHTI / CABOS FORJADOS

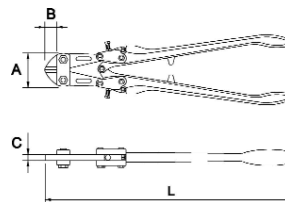

| COD | L | A | B | C | CAP 55kg/mm² / 142kg/mm² | Kg. | |
|-------|-----|-----|------|-----|-----------------------------|-----|---|
| 62785 | 14" | 61 | 26 | 7 | 7-5 | 1,3 | 1 |
| 62786 | 18" | 71 | 32 | 8 | 8-6 | 1,8 | |
| 62787 | 24" | 85 | 34 | 9,5 | 10-8 | 3,2 | |
| 62788 | 30" | 96 | 39,5 | 11 | 13-10 | 4,7 | |
| 62789 | 36" | 108 | 43 | 13 | 16-12 | 7 | |

| COD | L |
|-------|-----|
| 64453 | 14" |
| 64454 | 18" |
| 64455 | 24" |
| 64456 | 30" |
| 64457 | 36" |



KIT 9 PCS.
PCS. COD:62192

| | | |
|---|-------|-----|
| 2 | 62785 | 14" |
| 2 | 62786 | 18" |
| 2 | 62787 | 24" |
| 2 | 62788 | 30" |
| 1 | 62789 | 36" |

MANGOS FORJADOS / FORGED HANDLES / MANCHES FORGÉS / STAHL GESCHMIEDET / MANICI FORGIHTI / CABOS FORJADOS
BOCAS HSS / HSS BLADES / BECS HSS / SCHNELLSTAHL MESSER / LAMA HSS / HSS MESSEN / BOCAS HSS

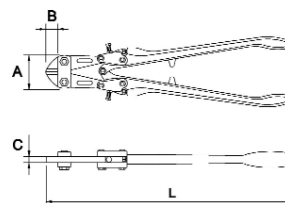

NEW HSS

| COD | L | A | B | C | HSS | CAP 55kg/mm² / 142kg/mm² | Kg. | |
|-------|-----|-----|------|-----|-----|-----------------------------|-----|---|
| 62808 | 18" | 71 | 32 | 8 | HSS | 8-6 | 1,8 | 1 |
| 62809 | 24" | 85 | 34 | 9,5 | | 10-8 | 3,2 | |
| 62810 | 30" | 96 | 39,5 | 11 | | 13-10 | 4,7 | |
| 62811 | 36" | 108 | 43 | 13 | | 16-12 | 7 | |

| COD | HSS | L |
|-------|-----|-----|
| 64453 | HSS | 18" |
| 64454 | | 24" |
| 64455 | | 30" |
| 64456 | | 36" |



Capaz de cortar varilla hasta 500°C
Able to cut bolts up to 500°C
Coupe possible de barres jusqu'à 500C

MANGOS DE ALUMINIO / ALLUMINIUM HANDLES / MANCHES EN ALUMINIUM / ALU GRIFFE / MANICO IN ALLUMINIO / ALUMINIUM GREPEN / CABO DE ALUMÍNIO

NEW

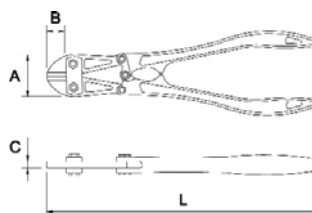

| COD | L | A | B | C | CAP 25Kg/mm² 140Kg/mm² | Kg. | |
|-------|-----|----|----|---|---------------------------|------|---|
| 62798 | 12" | 51 | 20 | 6 | 3-5 | 0,78 | |
| 62799 | 14" | 61 | 26 | 7 | 7-5 | 1,14 | 1 |
| 62800 | 18" | 71 | 32 | 8 | 8-6 | 1,95 | |

| | L |
|-------|-----|
| 64667 | 12" |
| 64453 | 14" |
| 64454 | 18" |

CORTAVARILLAS FILO ANGULAR / ANGULAR EDGE BOLT CUTTERS / COUPE BOULON TRANCHANT ANGULAIRE / ECKRAND BOLZENSCHNEIDER / TAGLIABULLONI FILO ANGOLARE / HOEKKANT BOUTENSCHAAR / CORTA VARAÃO DE FIO ANGULAR

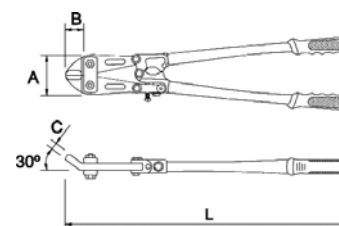

NEW

| COD | L | A | B | C | CAP 25Kg/mm² 140Kg/mm² | Kg. | |
|-------|-----|----|----|-----|---------------------------|-----|---|
| 62813 | 18" | 70 | 29 | 8 | 8-6 | 1,8 | 1 |
| 62814 | 24" | 85 | 33 | 9,6 | 10-8 | 2,6 | |

| | L |
|-------|-----|
| 64689 | 18" |
| 64690 | 24" |

CORTAVARILLAS / BOLT CUTTERS / COUPE-BOULONS / BOLZENSCHNEIDER / TAGLIABULLONI BOUTENSCHAREN / CORTA VARAÃO

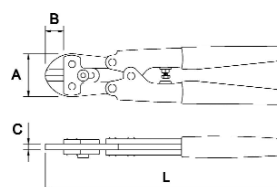

| COD | L | A | B | C | CAP 140Kg/mm² | Kg. | |
|-------|----|----|----|-----|------------------|-----|---|
| 62200 | 8" | 39 | 16 | 4,5 | 3 | 0,3 | 8 |

CORTAVARILLAS DE MESA / BOLT CUTTER BENCH TYPE / COUPE-BOULONS HORIZONTAL / TISCHBOLZENSCHNEIDER
TAGLIABULLONI DA BANCO / BANKBOUTENSCHAREN / CORTA VARÃO DE BANCADA

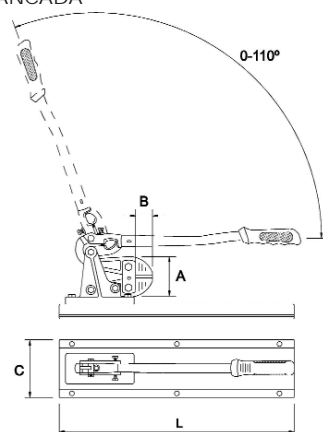

| COD | L | A | B | C | CAP | Kg. | |
|-------|-----|----|----|-----|--|-----|---|
| 62513 | 24" | 85 | 34 | 137 | 50Kg/mm ² 145Kg/mm ² | 5,7 | 1 |

| | |
|-------|-----|
| 64334 | 24" |
|-------|-----|

CORTAVARILLAS BOCA PELICANO / PELICAN BOLT CUTTER / COUPE-BOULONS "BEC PELICAN" / PELIKAAN-BOLZENSCHNEIDER
PELIKAAN BOUTSNIJDER / TAGLIABULLONI / TESOURA CORTA VARAO BOCA PELICANO

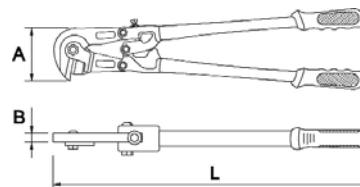

| COD | L | A | B | CAP | Kg. | |
|-------|-----|-----|-----|-----|------|---|
| 62514 | 24" | 101 | 9,5 | 9 | 2,77 | 1 |

| | |
|-------|-----|
| 64335 | 32" |
|-------|-----|

CORTACABLES DE ACERO / WIRE ROPE CUTTER / COUPE CABLES / STAHLDRAHTSCHNEIDER / CESOIA PER CAVI
STAALDRAADSNIJDER / TESOURA CORTA CABOS DE AÇO

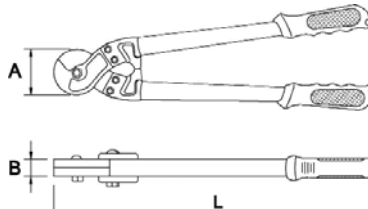

| COD | L | A | B | CAP | Kg. | |
|-------|-----|----|---|-----|------|---|
| 62515 | 18" | 67 | 8 | 12 | 1,68 | 1 |
| 62516 | 32" | 89 | 9 | 16 | 3,65 | |

| | |
|-------|-----|
| 64331 | 18" |
| 64332 | 32" |

CORTACABLES DE ACERO REFORZADO / H.D. WIRE ROPE CUTTER / COUPE CABLES EN ACIER RENFORCE
STAHLDRAPHTSCHNEIDER, VERSTÄRKT / CESCOIA PER CAVI / H.D. STAALDRAADSNIJDER
TESOURA CORTA CABOS DE AÇO REFORÇADO



| COD | L | A | B | CAP 55Kg/mm ² 140Kg/mm ² | Kg. | |
|-------|-----|-------|-----|---|-----|---|
| 62517 | 24" | 91,4 | 9,5 | 14-10 | 2,4 | 1 |
| 62518 | 36" | 103,4 | 13 | 18-12 | 4,7 | |
| 62519 | 42" | 119,2 | 15 | 22-13 | 7,9 | |

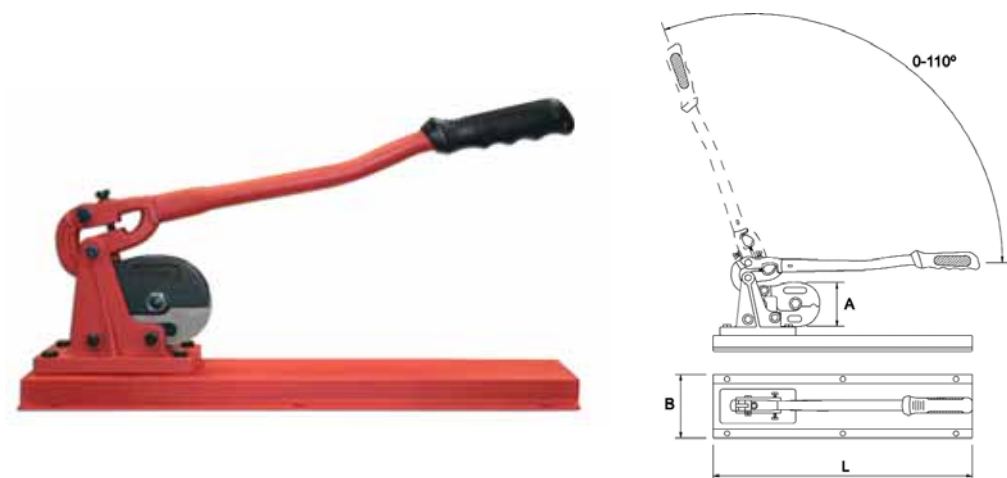

| COD | L | A | B | CAP 55Kg/mm ² 140Kg/mm ² | Kg. | |
|-------|-----|------|-----|---|-----|---|
| 62520 | 24" | 91,4 | 137 | 10-8 | 5,5 | 1 |

| COD | L |
|-------|-----|
| 64328 | 24" |
| 64329 | 36" |
| 64330 | 42" |

EGA Master S.A.
ART IN INNOVATION

TENAZA DE ENGASTAR / SWAGING TOOL / PINCE A SERTIR / KABELKLEMMZANGE / PINZA PER CAPICORDA / KABELKLEMTANG
TURQUES DE ENGASTAR



| | | | | | | |
|------------|-----|----|----|---------|-----|---|
| COD | | | | | | |
| 62521 | 24" | 86 | 12 | 1,5-6mm | 2,5 | 1 |

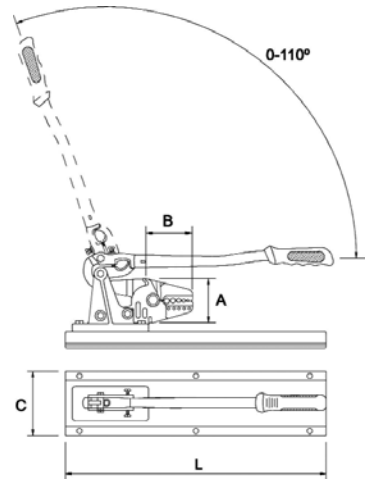

| | | | | | | | |
|------------|-----|----|----|-----|---------|-----|---|
| COD | | | | | | | |
| 62522 | 24" | 86 | 79 | 137 | 1,5-6mm | 5,8 | 1 |

| nº1 | nº2 | nº3 | nº4 | nº5 |
|--|--|---|---------------------------|---------------------------|
| Ø1,5 (2,35mm ²) Ø2 (3,14mm ²) | Ø2,5 (4,90mm ²) Ø2,8 (6,15mm ²) | Ø3(7,06mm ²) Ø3,5 (9,62mm ²) | Ø4(12,56mm ²) | Ø5(19,63mm ²) |

Para / for / pour:



| | |
|-------|-----|
| | |
| 64333 | 24" |

La más galardonada
The most awarded
La plus primée

ARCO DE SIERRA / HACK SAW / MONTURE DE SCIE A METAUX / METALLSÄGEBOGEN ARCHETTI / ZAAGBOGEN / ARCOS DE SERRA

KRONOS

45° & 90°

| | | | |
|------------|-----------|-----|---|
| COD | | | |
| 63742 | 12"-300mm | 905 | 6 |

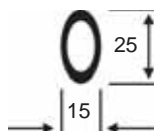

ALU

APOLO

45° & 90°

| | | | |
|------------|-----------|-----|---|
| COD | | | |
| 63749 | 12"-300mm | 730 | 6 |

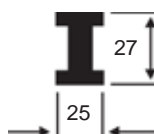

ALU

EFESTO

45° & 90°

| | | | |
|------------|-----------|-----|---|
| COD | | | |
| 63304 | 12"-300mm | 770 | 6 |

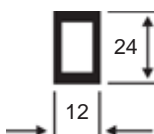

ALU

HERCULES

45° & 90°

| | | | |
|------------|-----------|-----|---|
| COD | | | |
| 63748 | 12"-300mm | 590 | 6 |

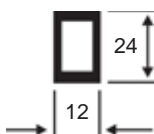

ALU

ULISES

45° & 90°

| | | | |
|------------|-----------|-----|---|
| COD | | | |
| 63747 | 12"-300mm | 560 | 6 |

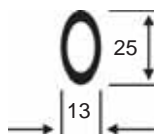

ALU + ABS

EOLO

45° & 90°

| | | | |
|------------|-----------|-----|---|
| COD | | | |
| 63746 | 12"-300mm | 530 | 6 |

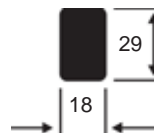

ABS

TITAN

90° & 180°

| | | | |
|------------|-----------|-----|---|
| COD | | | |
| 63745 | 12"-300mm | 450 | 6 |

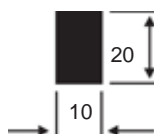

ACERO / STEEL / ACIER

MINIPROF 90°

| COD | 6"-150mm | 260 | 6 |
|-------|----------|-----|---|
| 63744 | | | |

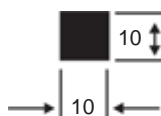

MINICUT 90° & 180°

| COD | 6"-150mm | 255 | 6 |
|-------|----------|-----|---|
| 63743 | | | |

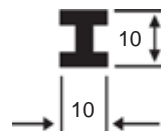

HOJAS DE SIERRA / HACK SAW BLADES / LAMES DE SCIÉS / METALLSÄGEBLÄTTER / LAME PER ARCHETTI / ZAAGBLADEN
FOLHA DE SERRA

ACERO AL CARBONO / CARBON STEEL / ACIER AU CARBONE

| COD | L | TPI | | Kg. |
|-------|-----|-----|-----|------|
| 64433 | 12" | 14 | 100 | 1,90 |
| 64434 | | 18 | | |
| 64435 | | 24 | | |
| 64436 | | 32 | | |



HSS-BIMETAL

| COD | L | TPI | | Kg. |
|-------|-----|-----|-----|------|
| 64437 | 12" | 14 | 100 | 1,90 |
| 64438 | | 18 | | |
| 64439 | | 24 | | |
| 64440 | | 32 | | |



IRROMPIBLE / UNBREAKABLE / INDÉCHIRABLÉ

HSS-BIMETAL (COBALT)

| COD | L | TPI | | Kg. |
|-------|-----|-----|-----|------|
| 64441 | 12" | 14 | 100 | 1,90 |
| 64442 | | 18 | | |
| 64443 | | 24 | | |
| 64444 | | 32 | | |



IRROMPIBLE / UNBREAKABLE / INDÉCHIRABLÉ

ACERO ESPECIAL TEMPLADO / HARDENED SPECIAL STEEL / ACIER TREMPÉ SPÉCIAL / GEHÄRTET SPEZIAL STAHL / ACCIAIO SPECIALE TEMPRATO / GEHARD SPECIAL STAAL / AÇO ESPECIAL TEMPERADO

| COD | L | TPI | gf | Blister |
|-------|----|-----|----|---------|
| 63771 | 6" | 24 | 30 | 6 |



NEW

SIERRA PARA PVC/ABS / PVC/ABS CUTTING SAW / SCIE A PVC / PVC/ABS SÄGE / SEGHETTO PER PVC/ABS / PVC/ABS ZAGEN
SERRA PARA PLÁSTICO

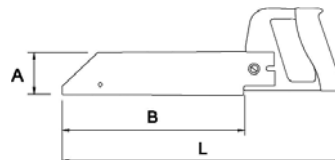

| COD | L | A | B | TPI | gf |
|-------|-----|------|-----------|-----|-----|
| 63379 | 395 | 64mm | 12" (300) | 18 | 300 |
| 64458 | | | | | |
| 64459 | | | | | |

TIJERAS ARTICULADAS / AVIATION TIN SNIPS / CISAILLE ARTICULEE / BLECHSCHEREN MIT HEBELÜBERSETZUNG
CESOIE A DOPPIA LEVA / KNIPSCHAREN TESOURAS ARTICULADAS

DR

| COD | mm | inch. | CAP | BT. | | |
|-------|-----|-------|-----|-----|---|---|
| 62169 | 250 | 10" | 1,2 | 380 | 6 | 1 |

Cr-V



| COD | mm | inch. | CAP | BT. | | |
|-------|-----|-------|-----|-----|---|---|
| 62170 | 250 | 10" | 1,2 | 380 | 6 | 1 |

Cr-V



ILGL

| COD | mm | inch. | CAP | BT. | | |
|-------|-----|-------|-----|-----|---|---|
| 62171 | 250 | 10" | 1,2 | 380 | 6 | 1 |

Cr-V



TIJERAS ARTICULADAS REFORZADAS / REINFORCED AVIATION TIN SNIPS / RENFORCEE CISAILLE ARTICULEE
BLECHSCHEREN MIT HEBELÜBERSETZUNG, VERSTÄRKT / CESOIE A DOPPIA LEVA RINFORZATA / VERSTERKET KNIPSCHAREN
TESOURAS ARTICULADAS REFORÇADAS

DR

| COD | mm | inch. | CAP | BT. | | |
|-------|-----|-------|-----|-----|---|---|
| 62188 | 250 | 10" | 1,2 | 470 | 6 | 1 |

Cr-V



ILGL

| COD | mm | inch. | CAP | BT. | | |
|-------|-----|-------|-----|-----|---|---|
| 62189 | 250 | 10" | 1,2 | 470 | 6 | 1 |

Cr-V



TIJERAS PARA CHAPA / TIN SNIPS / CISAILLES A TOLE / BLECHSCHEREN / CESOIE PER LAMIERA / HANDSCHAAR
TESOURA PARA CHAPA

| COD | inch. | CAP | BT. | | |
|-------|-------|-----|-----|---|---|
| 62232 | 8" | 0,5 | 350 | 6 | 1 |
| 62159 | 10" | 1 | 540 | | |
| 62233 | 12" | 1,2 | 700 | | |
| 62234 | 14" | 1,2 | 900 | | |



BRITISH TYPE

| COD | L | CAP | GT. | | |
|-------|-----|-----|-----|---|---|
| 62267 | 8" | 0,5 | 245 | 6 | 1 |
| 62268 | 10" | 1 | 490 | | |
| 62269 | 12" | 1,2 | 680 | | |
| 62270 | 14" | | 885 | | |



CIZALLA ROEDORA / RATCHET SNIP / GRIGNOTEUSE / NIBBELSCHERE / CESCOIE RODITRICI / KNIPSCHAAR MET RATEL TESOURA ROEDORA

| COD | L | CAP | GT. | | | |
|-------|-----|-----|-----|---|---|-------|
| 62160 | 10" | 1,2 | 465 | 6 | 1 | 80075 |



CORTADORES / CUTTERS / CUTTERS / CUTTER / COLTELLI UNIVERSALI / MESSEN / X-ACTOS

| COD | | | | | |
|-------|-----|-----|----|---|-------|
| 69501 | 0,6 | 115 | 10 | 1 | 64005 |



| COD | | | | | |
|-------|-----|----|----|---|-------|
| 69502 | 0,6 | 35 | 10 | 1 | 64005 |



| COD | | | | | |
|-------|-----|-----|----|---|-------|
| 69509 | 0,6 | 265 | 10 | 1 | 64005 |

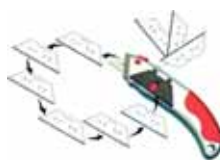

CARGA AUTOMÁTICA CON 10 CUCHILLAS / AUTOMATIC LOAD WITH 10 BLADES / CHARGE AUTOMATIQUE AVEC 10 LAMES

CORTAFRIOS / COLD CHISEL / BURINS / FLIESENMEISSEL / SCALPELLI ATAGLIENTE DIRITTO / ESCOPRO

| COD | HxL | GT. | | |
|-------|--------|-----|---|---|
| 63178 | 15x160 | 150 | 6 | 1 |
| 63179 | 20x200 | 275 | | |
| 63180 | 22x250 | 380 | | |



SET

| SET | | |
|-------|-------|-----------|
| 63761 | 63178 | 15x160 mm |
| | 63179 | 20x200 mm |
| | 63180 | 22x250 mm |



CINCEL CHAPISTA / EXTRA FLAT COLD CHISEL / BURIN DE CARROSSIER / SCHLITZMEISSEL / SCALPELLO A FREDDO PIATTO EXTRA PLATTE KOUDBEITEL / ESCOPRO FINO

| COD | L | A | GT. | | |
|-------|-----|----|-----|---|---|
| 63472 | 204 | 27 | 245 | 6 | 1 |

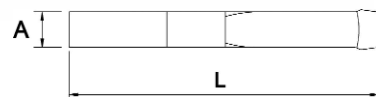

CINCEL / FLAT CHISEL / CISEAUX DE MAÇON / FLACHMEISSEL / SCALPELLI PER MURATORI / ESCOPRO

| COD | L | A | B | gr. | |
|-------|-----|----|----|------|---|
| 63309 | 200 | 23 | | 300 | |
| 63310 | 250 | 24 | 16 | 390 | |
| 63311 | | 24 | | 485 | |
| 63315 | 300 | 25 | | 580 | |
| 63316 | 350 | 26 | 18 | 700 | 6 |
| 63317 | | 27 | | 800 | |
| 63320 | 400 | 27 | | 950 | |
| 63321 | 500 | 28 | 20 | 1200 | |

| COD | L | A | B | gr. | |
|-------|-----|----|----|------|---|
| 63326 | 200 | 23 | | 450 | |
| 63327 | 250 | 24 | 16 | 540 | |
| 63328 | | 24 | | 635 | |
| 63332 | 300 | 25 | | 730 | |
| 63333 | 350 | 26 | 18 | 850 | 6 |
| 63334 | | 27 | | 950 | |
| 63337 | 400 | 27 | | 1100 | |
| 63338 | 500 | 28 | 20 | 1350 | |

PUNTERO / POINTED CHISEL / BROCHE / SPITZMEISSEL / SCALPELLI PER MURATORI / PONTEIRO

| COD | L | A | gr. | |
|-------|-----|----|------|---|
| 63339 | 200 | | 300 | |
| 63340 | 250 | 16 | 390 | |
| 63341 | | | 485 | |
| 63342 | 300 | | 580 | |
| 63343 | 350 | 18 | 700 | 6 |
| 63344 | | | 800 | |
| 63345 | 400 | | 950 | |
| 63346 | 500 | 20 | 1200 | |

| COD | L | A | gr. | |
|-------|-----|----|------|---|
| 63347 | 200 | | 450 | |
| 63348 | 250 | 16 | 540 | |
| 63349 | | | 635 | |
| 63350 | 300 | | 730 | |
| 63351 | 350 | 18 | 850 | 6 |
| 63352 | | | 950 | |
| 63353 | 400 | | 1100 | |
| 63354 | 500 | 20 | 1350 | |

CINCEL MECANICO / FLAT COLD CHISEL / BURIN MÉCANIQUE / FLACH MEIß EL / SCALPELLO PER MECCANICO / VLAkke BEITEL
ESCO PRO MECÁNICO

NEW



| COD | L | A | B | C | gr. | |
|-------|-----|----|----|-----|-----|---|
| 62847 | 100 | 11 | 7 | 12 | 65 | 6 |
| 62848 | 125 | 14 | 9 | 15 | 115 | |
| 62849 | 150 | 17 | 11 | 18 | 225 | |
| 62850 | 200 | 20 | 12 | 21 | 280 | |
| 62851 | 225 | | | 24 | 290 | |
| 62852 | 250 | | | 25 | 300 | |
| 62853 | 250 | 23 | 13 | 28 | 320 | |
| 62854 | 300 | | | 26 | 460 | |
| 62855 | 400 | | | 29 | 480 | |
| 62856 | 300 | 26 | 13 | 30 | 500 | |
| 62857 | 400 | | | 540 | | |
| 62858 | 500 | | | 30 | 560 | |

NEW



| COD | L | A | B | C | gr. | |
|-------|-----|----|----|-----|-----|---|
| 62862 | 200 | 20 | 12 | 21 | 330 | 6 |
| 62863 | 225 | | | 24 | 340 | |
| 62864 | 250 | | | 25 | 350 | |
| 62865 | 250 | 23 | 13 | 28 | 370 | |
| 62866 | 300 | | | 26 | 510 | |
| 62867 | 300 | | | 29 | 530 | |
| 62868 | 400 | 26 | 13 | 30 | 550 | |
| 62869 | 400 | | | 590 | | |
| 62870 | 500 | | | 30 | 610 | |

BURIL PLANO / CROSSCUT CHISEL / BÉDANE PLATE / KREUZSCHNITT MEIß EL / BULINO PIATTO / DWARSBEITEL / BURIL PLANO

NEW



| COD | L | A | B | C | gr. | |
|-------|-----|----|----|---|-----|---|
| 62871 | 125 | 14 | 9 | 5 | 90 | 6 |
| 62872 | 150 | 16 | 10 | 6 | 150 | |
| 62873 | 175 | 17 | 11 | 7 | 240 | |
| 62874 | 200 | 20 | 12 | 8 | 280 | |
| 62875 | 250 | 23 | 13 | 9 | 300 | |
| 62876 | 300 | | | 9 | 315 | |

NEW

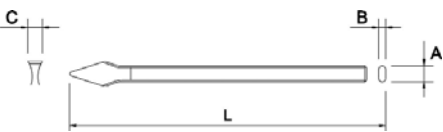

| COD | L | A | B | C | gr. | |
|-------|-----|----|----|---|-----|---|
| 62880 | 200 | 20 | 12 | 8 | 330 | 6 |
| 62881 | 250 | 23 | 13 | 9 | 350 | |
| 62882 | 300 | | | 9 | 365 | |

CINCEL PARA LADRILLOS / BOLSTER CHISEL / CISEAUX A BRIQUES / FUGENMEISSEL / SCALPELLI DA PIASTRELLISTA
ESCOPRO PARA LADRILHOS

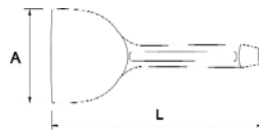

| COD | L | A | gr. | |
|-------|-----|-----|-----|---|
| 63181 | 220 | 60 | 355 | 6 |
| 63182 | 240 | 75 | 710 | |
| 63191 | | 100 | 875 | |

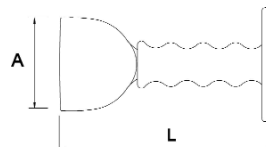

| COD | L | A | gr. | |
|-------|-----|-----|------|---|
| 63183 | 220 | 60 | 415 | 6 |
| 63184 | 240 | 75 | 740 | |
| 63192 | | 100 | 1040 | |

CINCELES, BOTADORES Y GRANETES / CHISELS AND PUNCHES / BURINS, CHASSE-GOUPILLES ET POINTEAUX / MEIß EL UND DURCHSCHLÄGE / SCALPELLI E PUNZONI / BEITELS EN DOORSLAGERS / ESCOPROS, SACA-TROÇOS E PUNÇÕES



NEW



NEW

| COD | Composición / Composition | gr. |
|----------|---|-----|
| A- 69953 | Cinzel mecánico / Cold chisel: 15x12x150 & 11x10x130mm Butil plano / Crosscut chisel: 5x10x150mm Granete / Center punch: 3x10x120mm | 675 |
| B- 69954 | Botador cilíndrico / Pin punch: 4x10x130mm Botador cónico / Taper punch: 3x10x120mm | 700 |

HACHAS / AXES / HACHES / ÄXTE / ASCIA / BIJLEN / MACHADOS

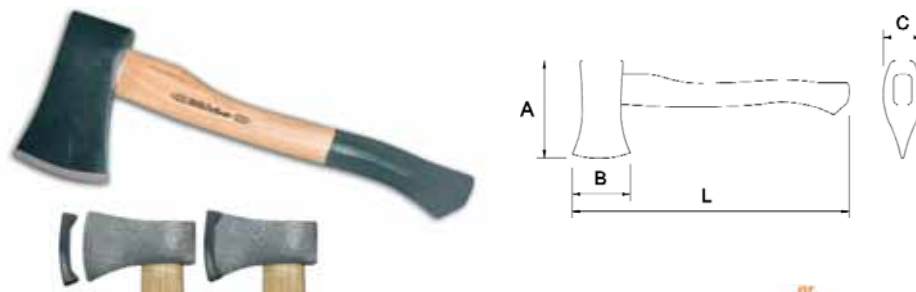

| COD | L | A | B | C | gr. | |
|-------|-----|-----|-----|----|------|---|
| 67231 | 450 | 144 | 95 | 21 | 700 | 6 |
| 67232 | | 145 | | 22 | 800 | |
| 67233 | 600 | 159 | 100 | 23 | 1000 | |
| 67234 | 700 | 174 | 110 | 27 | 1200 | |
| 67235 | 800 | 185 | 120 | 27 | 1500 | |
| 67236 | | 195 | 130 | 28 | 2000 | |

MAZA CUÑA / WEDGE HAMMER / MASSE COIN / SPALTHAMMER / MARTELLO A CUNEO / SPLIJTHAMER / MALHOS

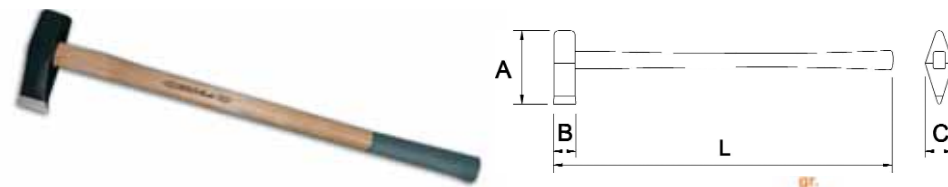

| COD | L | A | B | C | gr. | |
|-------|-----|-----|----|----|-----|---|
| 67237 | 900 | 204 | 65 | 55 | 300 | 6 |

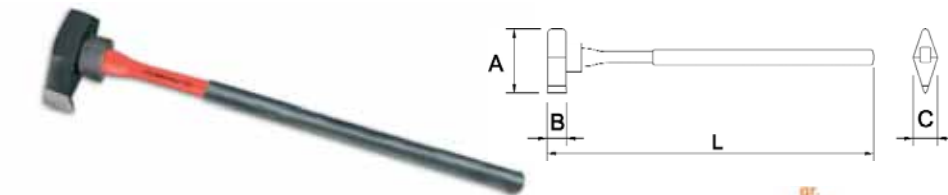

| COD | L | A | B | C | gr. | |
|-------|-----|-----|----|----|-----|---|
| 67238 | 900 | 204 | 65 | 55 | 300 | 6 |

FIBRA DE VIDRIO / FIBERGLASS / FIBRE DE VERRE / FIBRA DI VETRO / FIBERGLASSTIEL / FIBRA DE VIDRO

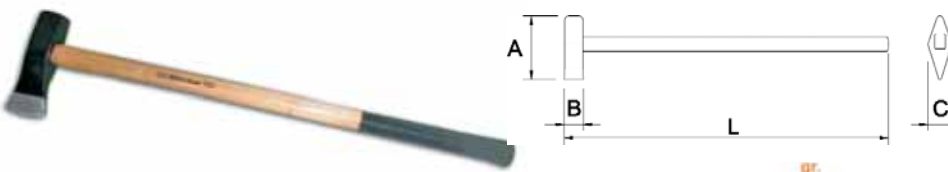

| COD | L | A | B | C | gr. | |
|-------|-----|-----|----|----|-----|---|
| 67239 | 900 | 208 | 90 | 52 | 250 | 6 |

HACHA BOMBERO / FIREMAN TYPE AXE / HACHE POUR POMPIERS / FEUERWEHRAXT / ASCIA TIPO PER POMPIERI
BRANDWEER BIJL / MACHADO DE BOMBEIRO

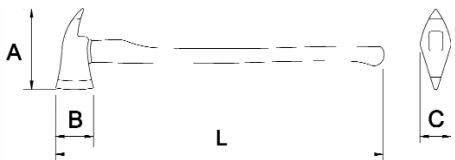
| COD | L | A | B | C | Gr. | |
|-------|-----|-----|-----|----|-----|---|
| 67240 | 910 | 248 | 105 | 32 | 150 | 6 |

| COD | L | A | B | C | Gr. | |
|-------|-----|-----|-----|----|-----|---|
| 67241 | 910 | 248 | 105 | 32 | 150 | 6 |

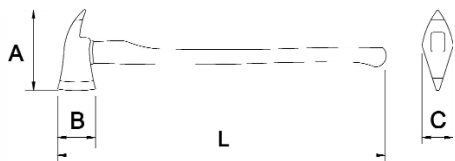
FIBRA DE VIDRIO / FIBERGLASS / FIBRE DE VERRE / FIBRA DI VETRO / FIBERGLASSTIEL / FIBRA DE VIDRO

HACHA AZADA / HOE AXE / HACHE HOUE / WIEDEHOPFHACKE / ACE PER ZAPPA / MACHADO ENXADA

| COD | L | A | B | C | D | Gr. | |
|-------|-----|-----|-----|----|----|------|---|
| 67242 | 910 | 307 | 110 | 82 | 29 | 1500 | 6 |

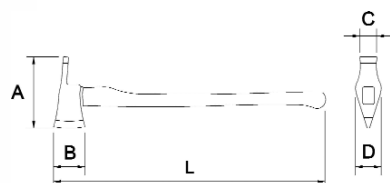
| COD | L | A | B | C | D | Gr. | |
|-------|-----|-----|-----|----|----|------|---|
| 67243 | 910 | 307 | 110 | 82 | 29 | 1500 | 6 |

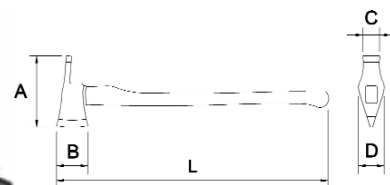
FIBRA DE VIDRIO / FIBERGLASS / FIBRE DE VERRE / FIBRA DI VETRO / FIBERGLASSTIEL / FIBRA DE VIDRO

MACHETES / MACHETS / MACHETTES / MESSER / MACETE / CATANAS

| COD | L | gr. | |
|-------|-----|-----|----|
| 67245 | 19" | 540 | 48 |
| 67246 | 21" | 630 | |



| COD | L | gr. | |
|-------|-----|-----|----|
| 67247 | 16" | 570 | 48 |
| 67248 | 18" | 600 | |
| 67249 | 19" | 615 | |



| COD | L | gr. | |
|-------|-----|-----|----|
| 67250 | 16" | 400 | 48 |
| 67251 | 18" | 450 | |
| 67252 | 21" | 530 | |



| COD | L | gr. | |
|-------|-----|-----|----|
| 67253 | 16" | 420 | 48 |
| 67254 | 18" | 460 | |
| 67255 | 21" | 550 | |



| COD | L | gr. | |
|-------|-----|-----|----|
| 67256 | 18" | 430 | 48 |
| 67257 | 20" | 450 | |
| 67258 | 22" | 490 | |



SIERRAS DE CORONA BIMETAL / BI-METAL HOLE SAWS / SCIES CLOCHES BI-MÉTAL / BI-MATEALL LOCHSÄGEN / SEGHE A TAZZA BI-METAL / BI-METAL GATZAGEN / SERRAS CRANEANAS BI-METÁLICAS

HSS BI-METAL

4/6 TPI

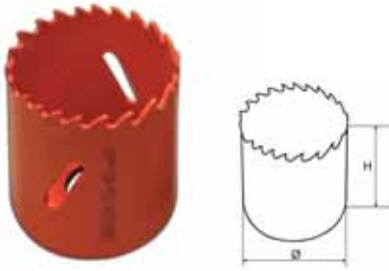



| COD | Ø (mm) | Ø (inch.) | H (mm) |  | r.p.m. | | | | | |
|-------|--------|-----------|--------|---|---------------------------|-------|----------------------|-----------------------|----------------|----------------|
| | | | | | acero dulce mild steel | inox | fundición casting | aluminio aluminium | latón brass | madera wood |
| 64550 | 14 | 9/16" | 54 | 64601 | 620 | 300 | 400 | 900 | 790 | 3000 |
| 64551 | 16 | 5/8" | | | 545 | 260 | 360 | 810 | 735 | |
| 64552 | 17 | 11/16" | | | 510 | 250 | 340 | 770 | 690 | |
| 64553 | 19 | 3/4" | | | 460 | 220 | 300 | 685 | 620 | |
| 64664 | 20 | - | | | 430 | 210 | 290 | 650 | 590 | |
| 64554 | 21 | 13/16" | | | 415 | 200 | 275 | 620 | 560 | |
| 64555 | 22 | 7/8" | | | 395 | 190 | 260 | 590 | 535 | |
| 64556 | 24 | 15/16" | | | 360 | 175 | 240 | 540 | 490 | |
| 64557 | 25 | 1" | | | 350 | | 235 | 525 | 470 | |
| 64558 | 27 | 1.1/16" | | | 50 | 64601 | 320 | 160 | 215 | |
| 64559 | 28 | - | 310 | 150 | | | 205 | 450 | 405 | |
| 64560 | 29 | 1.1/8" | 300 | 145 | | | 200 | 430 | 390 | |
| 64561 | 30 | 1.13/16" | 290 | 140 | | | 190 | 410 | 370 | |
| 64562 | 32 | 1.1/4" | 270 | 130 | | | 180 | 390 | 355 | |
| 64563 | 33 | 1.5/16" | 265 | 125 | | | 175 | 370 | 335 | |
| 64564 | 35 | 1.3/8" | 250 | 120 | | | 165 | 350 | 320 | |
| 64565 | 37 | 1.7/16" | 235 | 115 | | | 155 | 340 | 310 | |
| 64566 | 38 | 1.1/2" | 230 | 110 | | | 150 | 325 | 295 | |
| 64567 | 40 | 1.9/16" | 215 | 105 | | | 145 | 315 | 285 | |
| 64568 | 41 | 1.5/8" | 210 | 100 | 140 | 300 | 275 | | | |
| 64569 | 43 | 1.11/16" | 200 | 95 | 135 | 295 | 270 | 2100 | | |
| 64570 | 44 | 13/4" | 195 | | 130 | 280 | 255 | | | |
| 64571 | 46 | 1.13/16" | 190 | 90 | 125 | 270 | 245 | 2000 | | |
| 64572 | 48 | 1.7/8" | 180 | | 120 | 255 | 230 | | | |
| 64573 | 51 | 2" | 170 | 85 | 115 | 245 | 220 | | | |
| 64574 | 52 | 1.1/16" | 165 | 80 | 110 | 240 | 215 | | | |
| 64575 | 54 | 2.1/8" | 160 | 75 | 105 | 230 | 205 | 1800 | | |
| 64576 | 57 | 2.1/4" | 150 | | 100 | 220 | 200 | | | |
| 64577 | 59 | 2.51/16" | 145 | 70 | 100 | 215 | 195 | 1500 | | |
| 64578 | 60 | 2.3/8" | 140 | | 95 | 205 | 185 | | | |
| 64579 | 64 | 2.1/2" | 44 | 64602 | 135 | 65 | 90 | 200 | 180 | 1200 |
| 64580 | 65 | 2.9/16" | | | | | 90 | 195 | 175 | |
| 64581 | 67 | 2.5/8" | | | 130 | 85 | 190 | 170 | 1800 | |
| 64582 | 70 | 2.3/4" | | | 125 | | 60 | 185 | | 165 |
| 64583 | 73 | 2.7/8" | | | 120 | 80 | 180 | 160 | 1500 | |
| 64584 | 76 | 3" | | | 115 | | 55 | 170 | | 150 |
| 64585 | 79 | 3.1/8" | | | 110 | 75 | 165 | 145 | 1200 | |
| 64586 | 83 | 3.1/4" | | | 105 | | 50 | 155 | | 140 |
| 64587 | 86 | 3.3/8" | | | 100 | 70 | 150 | 135 | 1000 | |
| 64588 | 89 | 3.1/2" | | | 95 | | 45 | 65 | | 145 |
| 64589 | 92 | 3.5/8" | 140 | 125 | | | | | | |
| 64590 | 95 | 3.3/4" | 90 | 60 | 135 | 120 | 800 | | | |
| 64591 | 98 | 3.7/8" | 88 | | 130 | 120 | | | | |
| 64592 | 102 | 4" | 85 | 55 | 125 | 110 | 700 | | | |
| 64593 | 105 | 4.1/8" | 83 | | 40 | | | 120 | | |
| 64594 | 108 | 4.1/4" | 80 | 50 | 115 | 105 | 1000 | | | |
| 64595 | 110 | 4.5/16" | 78 | | | | | 70 | 150 | 135 |
| 64596 | 114 | 4.1/2" | 76 | 45 | 110 | 100 | 800 | | | |
| 64597 | 121 | 4.3/4" | 72 | | | | | 35 | 100 | 90 |
| 64598 | 127 | 5" | 68 | 40 | 90 | 85 | 700 | | | |
| 64599 | 140 | 5.1/2" | 62 | | | | | 30 | 40 | 85 |
| 64600 | 152 | 6" | 55 | 25 | 30 | 85 | 75 | | | |

19

CORTE / CUTTING / OUTILS COUPANTS / SCHNEIDWERKZEUG / ARCHETTI SNIJWERKTUIGEN

HUSILLO / ARBOR / VERRIN / HALTER / SUPPORTO / HOUDER / FUSO

| COD | Ø (mm) |  |  |
|-------|--------|---|---|
| 64601 | 14-30 | 3/8" - 9,52 | 1 |
| 64602 | 32-152 | 7/16" - 11,1 | |



CONECTOR ADAPTADOR ROSCA / THREAD CONNECTION ADPTER / CONNECTEUR ADAPTATEUR DE FILETAGE / ADAPTOR VERBINDUNGSADAPTER FUR GEWINDE / ADDATTATORE CONNETTORE PER FILIERA / ADAPTADOR DE ROSCA

| COD |  |  |  |
|-------|---|---|---|
| 64612 | 20 | 10 | 1 |



ALARGADERA / EXTENSION / RALLONGE / VERLÄNGERUNG / PROLUNGA / VERLENGSTUK / EXTENÇÃO

| COD |  | L |  |  |  |
|-------|---|-----|---|---|---|
| 64613 | 7/16" - 11,1 | 300 | 290 | 10 | 1 |



BROCA / DRILL / FORET CONIQUE / BOHRER / PUNTE / BOOR / BROCA

| COD |  |  |  |  |
|-------|--|--|--|--|
| 64614 | 75 | 15 | 10 | 1 |



SETS

| COD | Ø (mm) |  |  |  |  |
|-------|----------------------|---|---|---|---|
| 64615 | 19-22-35 38-44-67 | 64601-64602 | 64612 | 1500 | 1 |



| COD | Ø (mm) |  |  |  |  |
|-------|----------------------|---|---|---|---|
| 64651 | 16-21-25 32-40-51 | 64601-64602 | 64612 | 1500 | 1 |



| COD | Ø (mm) |  |  |  |  |  |
|-------|----------------------------------|---|---|---|---|---|
| 64616 | 19-22-29-35-38 44-51-57-64-67 | 64601-64602 | 64612 | 64613 | 300 | 1 |



BROCA ESCALONADA / STEP DRILL / FORET ÉTAGÉ / SPIRALBOHRER / PUNTA SCANALATA SPIRAALBOOR / BROCA ESCALONADA

| COD | Ø (mm) | | | |
|-------|--------|-----|---|---|
| 64617 | 4-12 | 25 | 1 | 1 |
| 64618 | 4-20 | 60 | | |
| 64619 | 4-30 | 180 | | |

SET

| COD | Ø (mm) | | |
|-------|----------------------|---|---|
| 64620 | 4-12 4-20 4-30 | 1 | 1 |



EXTRACTORES DE TORNILLOS / SCREW STRACTORS / EXTRACTEUR DE VIS SCHRAUBENAUSDREHER / ESTRATTORI / TAPEINDUITHALERS / EXTRACTORES DE PERNOS

| COD | M | | | | | |
|-------|-------|-------|------|------|------|-----|
| 61583 | 3-6 | 52,5 | 2,6 | 3,9 | 2,5 | 5 |
| 61584 | 6-8 | 57 | 3,0 | 4,3 | 3,0 | 10 |
| 61585 | 8-11 | 65 | 4,0 | 6,3 | 4,5 | 20 |
| 61586 | 11-14 | 75 | 4,5 | 7,5 | 6,0 | 30 |
| 61587 | 14-18 | 83 | 7,0 | 10,8 | 8,0 | 50 |
| 61588 | 18-25 | 92,5 | 8,9 | 14,9 | 11,0 | 100 |
| 61589 | 25-35 | 97 | 9,7 | 18,9 | 14,0 | 150 |
| 61590 | >35 | 101,5 | 14,9 | 24,0 | 20,0 | 200 |

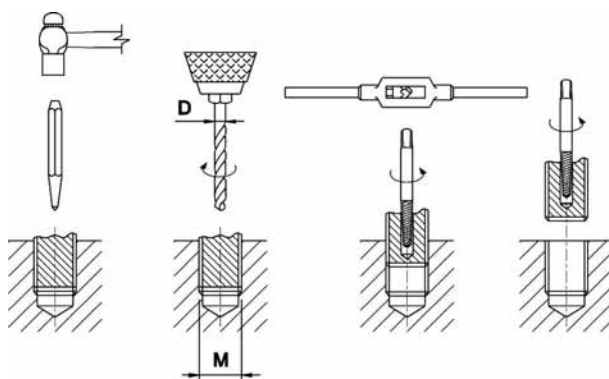



| SET | Composición/Composition | pcs. | |
|-------|--|------|-----|
| 61591 | 61583, 61584, 61585 61586, 61587 | 5 | 100 |
| 61592 | 61583, 61584, 61585 61586, 61587, 61588 | 6 | 200 |
| 61593 | 61583, 61584, 61585 61586, 61587, 61588 61589, 61590 | 8 | 750 |





19

CORTE / CUTTING / OUTILS COUPANTS / SCHNEIDWERKZEUG / ARCHETTI SNIJWERKTUIGEN

SACABOCADOS / HOLLOW PUNCHES / EMPORTE PIÈCES / HENKELLOCHEISEN / SACA-
BOCADOS / HOLPIJPEN / SACA BOCADOS

| COD | PCS | O.D (mm) |  |  |
|-------|-----|------------------------------|---|---|
| 64670 | 10 | 5-6-8-10-12 5-16-20-25-32 | 90° | 1 |



| COD | Ø (mm) |  |  |  |
|-------|--------|---|---|---|
| 64671 | 5 | 27 | 15 | 10 |
| 64672 | 6 | | 20 | |
| 64673 | 8 | | 25 | |
| 64674 | 10 | | 30 | |
| 64675 | 12,5 | | 40 | |
| 64676 | 16 | | 50 | |
| 64677 | 20 | | 60 | |
| 64678 | 25 | | 80 | |
| 64679 | 32 | | | |



| COD | Ø (mm) |  |  |
|-------|--------|---|---|
| 64680 | 5-32 | 250 | 1 |



CIZALLA CORTACHAPAS / METAL PLATE CUTTER / CISAILLE COUPE TOLE / SCHNEIDER FÜR METALLPLATTE / CESOIA TAGLIA LAMIERA / STAALPLAATSNIJDER / GUILHOTINA CORTA CHAPAS



CE *G12
NEW

| COD | V | W | Kg. |
|-------|------|------|-----|
| 60269 | 230V | 660W | 3,5 |

Especificaciones técnicas / Technical specification / Détails techniques

| | |
|---|--------------|
| Para chapas de acero, acero inoxidable, aluminio, cobre... / for steel, stainless steel, aluminium, copper... Pour de la tôle d'acier, d'Inox, d'Aluminium, de cuivre... | ● |
| Espesores máximos de chapa / Plate maximum thickness / Epaisseurs maximum de tôle | |
| 800N/mm2 | 1,5 |
| 600N/mm2 | 2,5 |
| 400N/mm2 | 3,2 |
| 200N/mm2 | 4 |
| Mínimo radio de corte curvo / Minimum radio of curved cutting / Rayon minimum de courbure en coupure | 500mm |
| Velocidad cuchillas / Blade Speed / Vitesse de lame | 1600spm |
| Dimensiones generales / Overall dimensions / Dimensions générales | 200x90x250mm |
| Longitud de cable / Wire lenght / Longueur de câble | 2,5m |
| Juego de cuchillas / Blade set / Jeu de lames | 85200 |
| LLave allen / Allen Key / Clé mâle | 4mm |
| Galga de calibración / Calibration Gage / Jauge | ● |
| Empuñadura de puente / Bridge type hilt / Manche en U | ● |
| Cuchillas reversibles / Reversible blades / Lames réversibles | ● |
| Cuchillas reafilables / Resharpenable blades / Lames affutables | ● |
| Cuchillas ajustables / Adjustable blades / Lames ajustables | ● |
| Buena visión de línea de corte / Good view of cutting line / Bonne vision de ligne de coupe | ● |
| Fácil manejo para zurdos / Easy use for left-handed people / Utilisation facile par les sourds | ● |



CORTACHAPAS / PLATE CUTTER / COUPE TOLE / METALLPLATTE SCHNEIDER
TAGLIALAMIERA / METAALPLAATSNIJDER / CORTA CHAPAS

| COD | V | W | Kg. |
|---|------|------|-------|
| 60126 | 230V | 560W | 3 |
| 60127 | 110V | | |
| Especificaciones técnicas / Technical specification / Détails techniques | | | |
| Taladro incluido / Included drill machine / Perceuse inclus | | | ● |
| Estuche de aluminio / Aluminium case / Etui en aluminium | | | ● |
| Cabezas de corte a izquierdas / Left cutting heads / Têtes de coupe à gauche | | | 2 pcs |
| Cabezas de corte a derechas / Right cutting heads / Têtes de coupe à droite | | | |
| Max. espesor chapa acero / Steel max. thickness / Epaisseur maximum tôle en acier | | | 1,5mm |
| Max. espesor chapa acero INOX / Stainless steel max. thickness / Epaisseur maximum tole en INOX | | | 1mm |





MARTILLO ANTIRREBOTE DEAD BLOW HAMMER MARTEAU ANTI REBOND

La amplísima gama de martillos, mazas y macetas EGA Master, tanto con mangos de madera de la mayor calidad como en fibra de vidrio super-resistente, se ve ampliada por las nuevas MAZAS ANTI-REBOTE.

The already very wide range of hammers and mallets, offered both with the best quality wood or super-resistant fiberglass handles, is now extended with the new DEAD BLOW HAMMERS.

La plus grande gamme de marteaux, masses et massettes EGA Master, tant avec des manches de grande qualité, comme en fibre de verre super résistant, se voit agrandie avec les nouvelles masses anti-rebond.

1 Su cabeza rellena de microbolas de acero le da la inercia necesaria para amortiguar y eliminar el efecto rebote.

The steel-ball-filled head gives it the necessary inertia to cushion and eliminate the rebound effect.

Sa tête remplie de microboules en acier, lui donne une inertie pour amortir et éliminer l'effet de rebond.

2 La carcasa hecha de una mezcla de goma especial+PVC, no solo le da la rigidez y resistencia necesarias sino que permite el golpeo de piezas metálicas sin riesgo a roturas o desperfectos, además de amortiguar aún más el impacto.

PVC+Special rubber made cover, provide not only the required rigidity and resistance but it also enables it to impact metal pieces without any risk of damaging or breaking them. Furthermore, it helps to cushion the impact further.

La carcassa faite d'un mélange de gomme spéciale + PVC, non seulement lui confère la rigidité et la résistance nécessaires, mais aussi permet des coups sur les pièces métalliques, sans risque de ruptures ou de détériorations, et en plus d'amortir plus le choc.



2

1

3

4

3 Zona de impacto reforzada

Reinforced impact zone

Zone d'impact renforcée

4 Efecto anti-rebote

Dead blow effect

Effet anti-rebond



ANTIRREBOTE / DEAD BLOW HAMMER / MARTEAU ANTI REBOND / HAMMER RÜCKSCHLAGFREI / MARTELLO ANTIRIMBALZO
HAMER TERUGSLAGVRIJ / MARTELO SEM RICOCHETE

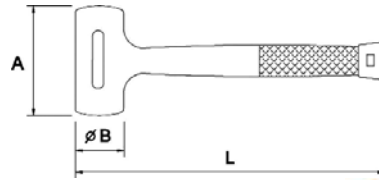

| COD | L | A | øB | | | |
|-------|-----|-----|----|--------|---|---|
| 69748 | 275 | 80 | 40 | 0,5 Lb | | |
| 69749 | 305 | 100 | 45 | 1 Lb | | |
| 69750 | 325 | 110 | 50 | 1,5 Lb | 6 | 1 |
| 69751 | 340 | 120 | 55 | 2 Lb | | |
| 69752 | 360 | 130 | 60 | 3 Lb | | |
| 69753 | 425 | 140 | 65 | 4 Lb | 3 | - |
| 69754 | 430 | 150 | 70 | 5 Lb | | |
| 69755 | 430 | 165 | 75 | 6 Lb | | |

MAZA CUADRADA TIPO ALEMAN / GERMAN TYPE STONING HAMMER / MASE CARREE TYPE ALLEMAND / STEINSLEGGER / MAZZA
MARRETA QUADRADA

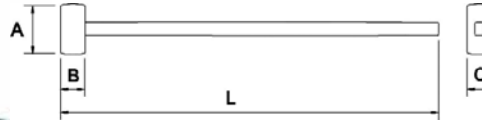

| COD | Kg. | | L | A | B | C | |
|-------|-----|-----------|-----|-----|----|----|---|
| 69640 | 3 | COD.81692 | 900 | 135 | 56 | 56 | 1 |
| 69641 | 4 | | | 145 | 61 | 64 | |
| 69642 | 5 | | | 151 | 68 | 68 | |
| 69643 | 6 | | | 165 | 70 | 70 | |

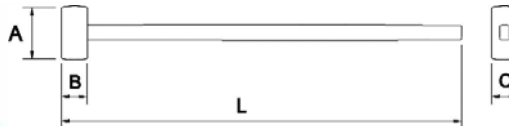

| COD | Kg. | | L | A | B | C | |
|-------|-----|-----------|-----|-----|----|----|---|
| 69644 | 3 | COD.81737 | 900 | 135 | 56 | 56 | 1 |
| 69645 | 4 | | | 145 | 61 | 64 | |
| 69646 | 5 | | | 151 | 68 | 68 | |
| 69647 | 6 | | | 165 | 70 | 70 | |

FIBRA DE VIDRIO / FIBERGLASS / FIBRE DE VERRE / FIBRA DI VETRO / FIBERGLASSTIEL / FIBRA DE VIDRO

MAZA DE CARAS OCTOGONALES / SLEDGE HAMMER / MASSE OCTOGONALE / STEINSLEGGER / MAZZA OTTOGONALE
MARRETA OCTOGONAL

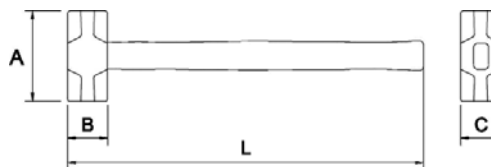

| COD | | | L | A | B | C | |
|-------|------|-----------|-----|-----|----|----|---|
| 69650 | 4Lb | COD.81693 | 400 | 136 | 51 | 48 | 1 |
| 69651 | 6Lb | | | 146 | 54 | 51 | |
| 69652 | 8Lb | COD.81694 | 900 | 161 | 58 | 59 | |
| 69653 | 10Lb | | | 173 | 64 | 62 | |
| 69654 | 12Lb | | | 180 | 66 | 66 | |

MACETA MOD. ESPAÑOL / SPANISH TYPE STONING HAMMER / MASSETTE ESPAGNOLE / FÄUSTEL / MAZZETA MOD. SPAGNOLO
 MARRETA MOD. ESPANHOL

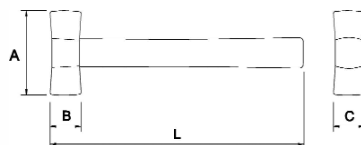

| COD | Kg. | | L | A | B | C | |
|-------|-----|-----------|-----|-----|----|----|---|
| 69659 | 0,7 | COD.81695 | 260 | 105 | 33 | 33 | 6 |
| 69660 | 1 | COD.81696 | 280 | 129 | 37 | 37 | |
| 69661 | 1,4 | | | 138 | 41 | 43 | |

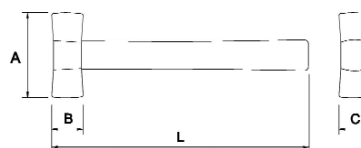

| COD | Kg. | | L | A | B | C | |
|-------|-----|-----------|-----|-----|----|----|---|
| 69662 | 0,7 | COD.81738 | 255 | 105 | 33 | 33 | 6 |
| 69663 | 1 | COD.81739 | 280 | 129 | 37 | 37 | |
| 69664 | 1,4 | | | 138 | 41 | 43 | |

FIBRA DE VIDRIO / FIBERGLASS / FIBRE DE VERRE / FIBRA DI VETRO / FIBERGLASSTIEL / FIBRA DE VIDRO

MACETA CUADRADA TIPO ALEMAN / GERMAN TYPE STONING HAMMER / MASSETTE TYPE ALLEMAND / FÄUSTEL / MAZZETA
 MARRETA

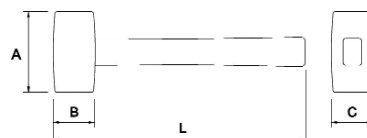

| COD | Kg. | | L | A | B | C | |
|-------|------|-----------|-----|----|----|----|---|
| 69665 | 0,8 | COD.81697 | 260 | 95 | 41 | 40 | 6 |
| 69605 | 1 | | | 95 | 41 | 40 | |
| 69606 | 1,25 | COD.81698 | 280 | 99 | 42 | 43 | |
| 69607 | 1,5 | COD.81699 | 280 | 99 | 42 | 43 | |

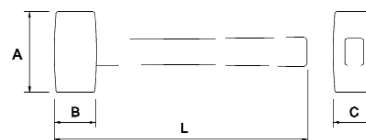

| COD | Kg. | | L | A | B | C | |
|-------|------|-----------|-----|----|----|----|---|
| 69666 | 0,8 | COD.81740 | 260 | 95 | 41 | 40 | 6 |
| 69667 | 1 | | | 95 | 41 | 40 | |
| 69668 | 1,25 | COD.81741 | 290 | 99 | 42 | 43 | |
| 69669 | 1,5 | | | 99 | 42 | 43 | |

FIBRA DE VIDRIO / FIBERGLASS / FIBRE DE VERRE / FIBRA DI VETRO / FIBERGLASSTIEL / FIBRA DE VIDRO

MACETA MODELO INGLES / BRITISH TYPE STONING HAMMER / MASSETTE TYPE ANGLAIS / FÄUSTEL / MAZZETA / MARRETA

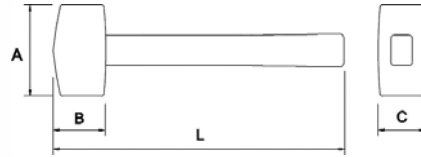

| COD | | | | | | | |
|-------|--------|-----------|-----|-----|----|----|---|
| 69671 | 2,5 Lb | COD.81700 | 280 | 92 | 45 | 45 | 1 |
| 69672 | 3 Lb | | | 104 | 46 | 45 | |

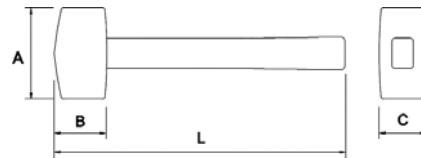

| COD | | | | | | | |
|-------|--------|-----------|-----|-----|----|----|---|
| 69673 | 2,5 Lb | COD.81742 | 280 | 92 | 45 | 45 | 1 |
| 69674 | 3 Lb | | | 104 | 46 | 45 | |

FIBRA DE VIDRIO / FIBERGLASS / FIBRE DE VERRE / FIBRA DI VETRO / FIBERGLASSTIEL / FIBRA DE VIDRO

MARTILLO ALEMÁN / GERMAN TYPE MACHINIST'S HAMMER / MARTEAU DE MECANICIEN / SCHLOSSERHAMMER, DEUTSCHE FORM
MARTELLO TEDESCO / BANKHAMER / MARTELO TIPO ALEMÃO

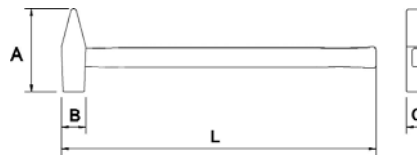

| COD | | | | | | | | |
|-------|------|-----------|-----|-----|----|----|---|---|
| 69618 | 200 | COD.81701 | 275 | 96 | 20 | 21 | 6 | 1 |
| 69619 | 300 | | | 103 | 23 | 23 | | |
| 69620 | 400 | COD.81702 | 305 | 118 | 27 | 28 | | |
| 69621 | 500 | COD.81703 | 325 | 118 | 27 | 28 | | |
| 69622 | 600 | | | 123 | 29 | 31 | | |
| 69675 | 800 | COD.81704 | 340 | 128 | 33 | 32 | | |
| 69676 | 1000 | COD.81705 | 355 | 135 | 37 | 37 | | |

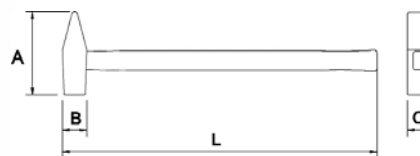

| COD | | | | | | | | |
|-------|------|-----------|-----|-----|----|----|---|---|
| 69731 | 200 | COD.81743 | 255 | 96 | 20 | 21 | 6 | 1 |
| 69732 | 300 | | | 103 | 23 | 23 | | |
| 69733 | 400 | COD.81744 | 275 | 118 | 27 | 28 | | |
| 69734 | 500 | COD.81745 | 300 | 118 | 27 | 28 | | |
| 69735 | 600 | | | 123 | 29 | 31 | | |
| 69736 | 800 | COD.81746 | 350 | 128 | 33 | 32 | | |
| 69737 | 1000 | | 350 | 135 | 37 | 37 | | |

FIBRA DE VIDRIO / FIBERGLASS / FIBRE DE VERRE / FIBRA DI VETRO / FIBERGLASSTIEL / FIBRA DE VIDRO

MARTILLO DE EBANISTA / JOINER'S HAMMER / MARTEAU DE MENUISIER / HOLZSCHNITZERHAMMER / MARTELLO FALEGNAME
 MARTELO DE PENNA

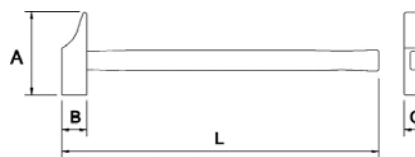

| COD | mm | | L | A | B | C | | | |
|-------|----|-----------|-----|-----|----|----|-----|---|---|
| 69601 | 18 | COD.81708 | 270 | 88 | 17 | 17 | 150 | 6 | 1 |
| 69602 | 20 | | | 93 | 20 | 19 | 200 | | |
| 69603 | 22 | | | 97 | 22 | 23 | 250 | | |
| 69604 | 25 | COD.81709 | 300 | 107 | 25 | 24 | 350 | | |
| 69681 | 28 | | | 116 | 28 | 27 | 450 | | |
| 69682 | 30 | | | 121 | 30 | 29 | 550 | | |

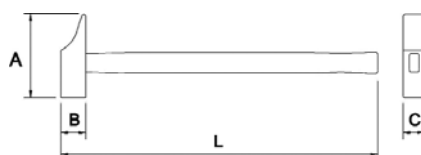

| COD | mm | | L | A | B | C | | | |
|-------|----|-----------|-----|-----|----|----|-----|---|---|
| 69684 | 18 | COD.81747 | 250 | 88 | 17 | 17 | 150 | 6 | 1 |
| 69685 | 20 | | | 93 | 20 | 19 | 200 | | |
| 69686 | 22 | | | 97 | 22 | 23 | 250 | | |
| 69687 | 25 | COD.81748 | 278 | 107 | 25 | 24 | 350 | | |
| 69688 | 28 | | | 116 | 28 | 27 | 450 | | |
| 69689 | 30 | | | 121 | 30 | 29 | 550 | | |

FIBRA DE VIDRIO / FIBERGLASS / FIBRE DE VERRE / FIBRA DI VETRO / FIBERGLASSTIEL / FIBRA DE VIDRO

MARTILLO RIVOIR / FRENCH TYPE MACHINIST'S HAMMER / MARTEAU RIVOIR / RIVOIR HAMMER / MARTELLO RIVOIR / TIPO RIVOIR
 MARTELO PENNA TIPO RIVOIR

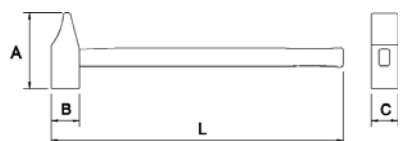

| COD | mm | | L | A | B | C | | | |
|-------|----|-----------|-----|-----|----|----|------|---|---|
| 69691 | 25 | COD.81711 | 280 | 96 | 22 | 25 | 250 | 6 | 1 |
| 69692 | 30 | COD.81712 | 300 | 96 | 29 | 30 | 375 | | |
| 69693 | 35 | COD.81713 | 350 | 102 | 38 | 35 | 675 | | |
| 69694 | 40 | | | 116 | 40 | 40 | 900 | | |
| 69695 | 45 | | | 124 | 44 | 45 | 1100 | | |
| 69697 | 50 | | | 130 | 47 | 50 | 1300 | | |

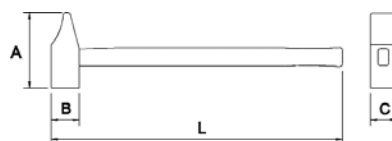

| COD | mm | | L | A | B | C | | | |
|-------|----|-----------|-----|-----|----|----|------|---|---|
| 69738 | 25 | COD.81749 | 270 | 96 | 22 | 25 | 250 | 6 | 1 |
| 69739 | 30 | COD.81750 | 300 | 96 | 29 | 30 | 375 | | |
| 69740 | 35 | | | 102 | 38 | 35 | 675 | | |
| 69741 | 40 | COD.81751 | 350 | 116 | 40 | 40 | 900 | | |
| 69756 | 45 | | | 124 | 44 | 45 | 1100 | | |
| 69757 | 50 | | | 130 | 47 | 50 | 1300 | | |

FIBRA DE VIDRIO / FIBERGLASS / FIBRE DE VERRE / FIBRA DI VETRO / FIBERGLASSTIEL / FIBRA DE VIDRO

MARTILLO DE BOLA / BALL PEIN HAMMER / MARTEAU A BOULE / SCHLOSSERHAMMER, ENGLISCHE FORM / MARTELLO A PALLA
 ENGELSE HAMMER MARTELO DE BOLA

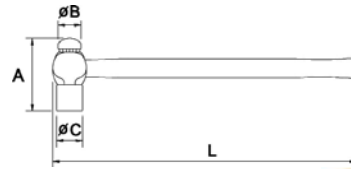

| COD | MOD. | | | | | | | | |
|-------|------|-----------|-----|-----|----|----|------|---|---|
| 69612 | A | COD.81714 | 280 | 80 | 22 | 23 | 250 | 1 | 1 |
| 69613 | B | COD.81715 | 300 | 94 | 27 | 30 | 350 | | |
| 69614 | C | COD.81716 | 320 | 104 | 28 | 30 | 500 | | |
| 69616 | E | COD.81717 | 340 | 118 | 30 | 32 | 700 | | |
| 69617 | F | COD.81718 | 370 | 127 | 32 | 39 | 1000 | | |

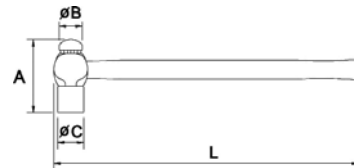

| COD | MOD. | | | | | | | | |
|-------|------|-----------|-----|-----|----|----|------|---|---|
| 69704 | A | COD.81752 | 270 | 80 | 22 | 23 | 250 | 1 | 1 |
| 69705 | B | COD.81753 | 300 | 94 | 27 | 30 | 350 | | |
| 69706 | C | | | 104 | 28 | 30 | 500 | | |
| 69707 | E | | | 118 | 30 | 32 | 700 | | |
| 69708 | F | COD.81754 | 340 | 127 | 32 | 39 | 1000 | | |

FIBRA DE VIDRIO / FIBERGLASS / FIBRE DE VERRE / FIBRA DI VETRO / FIBERGLASSTIEL / FIBRA DE VIDRO

MARTILLO DE ENCOFRADOR / SPANISH TYPE CLAW HAMMER / MARTEAU DE COFFREUR / KLAUEN HAMMER
 MARTELLO CARPENTIERE / MARTELO DE COFRADOR

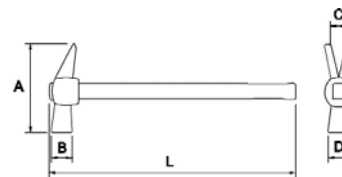

| COD | | | | | | | | | |
|-------|-----|-----------|-----|-----|----|----|----|---|---|
| 69711 | 300 | COD.81719 | 380 | 129 | 23 | 8 | 26 | 6 | 1 |
| 69712 | 400 | COD.81720 | 400 | 141 | 29 | 12 | 29 | | |
| 69713 | 500 | | | 142 | 29 | 12 | 29 | | |



| COD | | | | | | | | | |
|-------|-----|-----------|-----|-----|----|----|----|---|---|
| 69715 | 300 | | | 129 | 23 | 8 | 26 | 6 | 1 |
| 69716 | 400 | COD.81755 | 385 | 141 | 29 | 12 | 29 | | |
| 69717 | 500 | | | 142 | 29 | 12 | 29 | | |

FIBRA DE VIDRIO / FIBERGLASS / FIBRE DE VERRE / FIBRA DI VETRO / FIBERGLASSTIEL / FIBRA DE VIDRO

MARTILLO DE UÑA / CLAW HAMMER / MARTEAU D'EMBALEUR / KLAUEN HAMMER / MARTELLO CARPENTIERE
 MARTELO DE UNHA

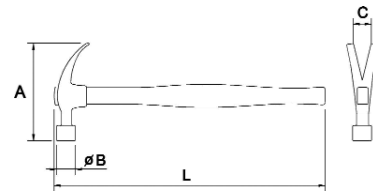

| COD | gr. | | L | A | øB | C | | |
|-------|-----|-----------|-----|-----|----|---|---|---|
| 69742 | 550 | COD.81723 | 320 | 138 | 30 | 7 | 6 | 1 |



| COD | gr. | | L | A | øB | C | | |
|-------|-----|-----------|-----|-----|----|---|---|---|
| 69719 | 550 | COD.81756 | 330 | 138 | 30 | 7 | 6 | 1 |

FIBRA DE VIDRIO / FIBERGLASS / FIBRE DE VERRE / FIBRA DI VETRO / FIBERGLASSTIEL / FIBRA DE VIDRO

MARTILLO DE UÑA MODELO AMERICANO / CLAW HAMMER / MARTEAU D'EMBALEUR / KLAUENHAMMER
 MARTELLO CARPENTIERE / MARTELO DE UNHA MOD. AMERICANO

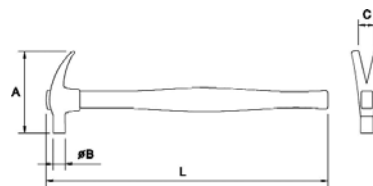

| COD | mm | | L | A | øB | C | gr. | |
|-------|----|-----------|-----|-----|----|---|-----|---|
| 69679 | 21 | COD.81724 | 280 | 102 | 23 | 6 | 250 | 6 |
| 69608 | 23 | COD.81725 | 300 | 111 | 23 | 6 | 350 | |
| 69609 | 25 | COD.81726 | 320 | 128 | 25 | 6 | 450 | |
| 69610 | 27 | | | 132 | 27 | 7 | 525 | |
| 69611 | 29 | | | 136 | 28 | 9 | 600 | |

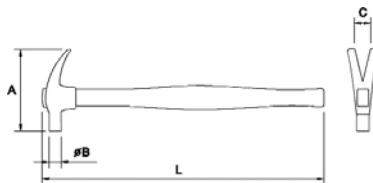

| COD | mm | | L | A | øB | C | gr. | |
|-------|----|-----------|-----|-----|----|---|-----|---|
| 69743 | 21 | COD.81757 | 300 | 102 | 23 | 6 | 250 | 6 |
| 69744 | 23 | | | 111 | 23 | 6 | 350 | |
| 69745 | 25 | | | 128 | 25 | 6 | 450 | |
| 69746 | 27 | | | 132 | 27 | 7 | 525 | |
| 69747 | 29 | | | 136 | 28 | 9 | 600 | |

FIBRA DE VIDRIO / FIBERGLASS / FIBRE DE VERRE / FIBRA DI VETRO / FIBERGLASSTIEL / FIBRA DE VIDRO

MARTILLO DE UÑA CABEZA CUADRADA / SQUARE HEAD CLAW HAMMER / MARTEAU D'EMBALLER / KLAUENHAMMER
 MARTELO A GANCHO / MARTELO DE UNHA BASE QUADRADA

| COD | mm | | | | | | | | | |
|-------|----|-----------|-----|-----|----|---|----|-----|---|---|
| 69696 | 28 | COD.81727 | 310 | 110 | 25 | 9 | 29 | 400 | 6 | 1 |

| COD | mm | | | | | | | | | |
|-------|----|-----------|-----|-----|----|---|----|-----|---|---|
| 69698 | 28 | COD.81760 | 380 | 110 | 25 | 9 | 29 | 400 | 6 | 1 |

FIBRA DE VIDRIO / FIBERGLASS / FIBRE DE VERRE / FIBRA DI VETRO / FIBERGLASSTIEL / FIBRA DE VIDRO

MARTILLO MECANICO DE PEÑA / ENGINEER'S CROSS PEIN HAMMER / MARTEAU A GARNIR / SCHLOSSERHAMMER
 MECCANICO CON PENNA / MECÁNICO DE PENA

| COD | | | | | | | | | | |
|-------|-----|-----------|-----|-----|---|----|----|---|---|--|
| 69700 | 200 | COD.81706 | 300 | 104 | 5 | 20 | 22 | 6 | 1 | |
| 69701 | 250 | | | 117 | 6 | 22 | 26 | | | |
| 69702 | 350 | COD.81707 | 320 | 118 | 6 | 25 | 26 | | | |

PICO DE CALDERERO / CHIPPING HAMMER / PIC DE CHAUDRONNIER / KESSELSTEINHAMMER / PICCONE DA BATTIRAME
 PICADEIRA DE CALDEIREIRO

| COD | | | | | | | | | | |
|-------|-----|-----------|-----|-----|----|----|----|---|---|--|
| 69678 | 450 | COD.81722 | 320 | 150 | 27 | 27 | 27 | 6 | 1 | |

MACETA DE NYLON / NYLON HAMMER / MARTEAU NYLON / NYLON- HAMMER / MARTELLO DI NYLON / MARTELO DE NYLON

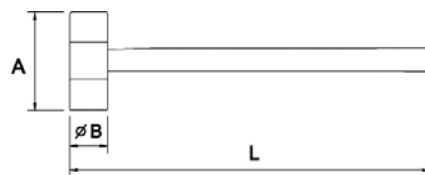

| COD | gr. | | L | A | øB | | |
|-------|-----|-----------|-----|-----|----|---|---|
| 69721 | 200 | COD.81728 | 320 | 20 | 30 | 6 | 1 |
| 69544 | 350 | | 370 | 91 | 35 | | |
| 69722 | 450 | COD.81729 | | 101 | 40 | | |

| COD | |
|-------|----|
| 81771 | 30 |
| 81197 | 35 |
| 81772 | 40 |

| COD | |
|-------|----|
| 81773 | 30 |
| 81198 | 35 |
| 81774 | 40 |

MACETA DE GOMA / BLACK RUBBER Mallet / MARTEAU EN CAOUTCHOUC / GUMMI-HAMMER / MAZUOLO DI GOMMA
MAÇO DE BORRACHA

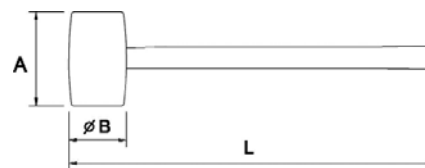

| COD | gr. | | L | A | øB | | |
|-------|-----|-----------|-----|-----|----|---|---|
| 69520 | 350 | COD.81730 | 320 | 89 | 55 | 6 | 1 |
| 69521 | 650 | | 370 | 114 | 65 | | |
| 69726 | 900 | COD.81731 | | 125 | 75 | | |

MACETA DE COBRE / SQUARE COPPER Mallet / MASSETTE CUIVRE / KUPFERHAMMER / MAZZETTA DI RAME
MARRETA DE COBRE

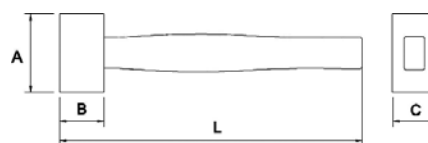

| COD | mm | gr. | | L | A | B | C | | |
|-------|----|------|-----------|-----------|-----|----|----|---|---|
| 69728 | 30 | 500 | COD.81732 | 240 | 77 | 26 | 29 | 6 | 1 |
| 69729 | 35 | 1000 | | COD.81733 | 260 | 88 | 36 | | |
| 69730 | 40 | 1500 | COD.81734 | 280 | 99 | 41 | 43 | | |

MACETA DE CANTERO / MASON HAMMER / MASSETTE DE TALLEUR DE PIERRES / MAURER-HAMMER / MAZZETA PACCAPETRE
MACETA DE CANTEIRO

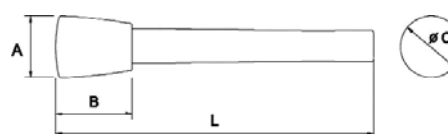

| COD | gr. | | L | A | B | øC | | |
|-------|------|-----------|-----|----|----|----|---|---|
| 69656 | 900 | COD.81735 | 230 | 65 | 58 | 62 | 6 | 1 |
| 69657 | 1100 | | | 68 | 61 | 67 | | |

PICOS / PICKS / DECINTROIRES / MAURER-HAMMER / PICCONI / PICADEIRA

| COD | gr. | COD.81736 | L | A | B | C | D | |
|-------|-----|-----------|-----|-----|----|---|----|---|
| 69759 | 400 | | 380 | 229 | 39 | 5 | 34 | 6 |
| 69760 | 500 | | | 237 | 41 | 6 | 35 | |

| COD | gr. | COD.81761 | L | A | B | C | D | |
|-------|-----|-----------|-----|-----|----|---|----|---|
| 69762 | 400 | | 385 | 229 | 39 | 5 | 34 | 6 |
| 69761 | 500 | | | 237 | 41 | 6 | 35 | |

FIBRA DE VIDRIO / FIBERGLASS / FIBRE DE VERRE / FIBRA DI VETRO / FIBERGLASSTIEL / FIBRA DE VIDRO

| COD | gr. | COD.81736 | L | A | B | |
|-------|-----|-----------|-----|-----|----|---|
| 69764 | 400 | | 380 | 236 | 36 | 6 |
| 69765 | 500 | | | 240 | 38 | |



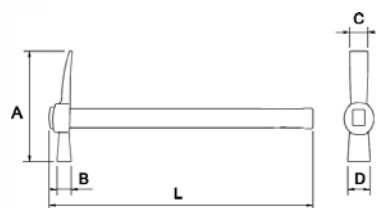

| COD | gr. | COD.81761 | L | A | B | |
|-------|-----|-----------|-----|-----|----|---|
| 69766 | 400 | | 385 | 236 | 36 | 6 |
| 69767 | 500 | | | 240 | 38 | |

FIBRA DE VIDRIO / FIBERGLASS / FIBRE DE VERRE / FIBRA DI VETRO / FIBERGLASSTIEL / FIBRA DE VIDRO

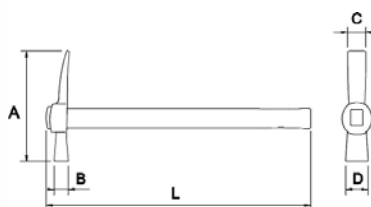

| COD | gr. |  |  | L | A | B | C | D |  |
|-------|-----|---|---|-----|-----|----|----|----|---|
| 69770 | 400 | COD.81736 |  | 380 | 237 | 10 | 10 | 36 | 6 |
| 69771 | 500 | | | 197 | 24 | 35 | 25 | | |



| COD | gr. |  |  | L | A | B | C | D |  |
|-------|-----|---|---|-----|-----|----|----|----|---|
| 69772 | 400 | COD.81761 |  | 385 | 237 | 10 | 10 | 36 | 6 |
| 69773 | 500 | | | 197 | 24 | 35 | 25 | | |

FIBRA DE VIDRIO / FIBERGLASS / FIBRE DE VERRE / FIBRA DI VETRO / FIBERGLASSTIEL / FIBRA DE VIDRO

EGA *Master* S.A.
ART IN INNOVATION

La más galardonada
The most awarded
La plus primée





Nueva gama de palas y palotes EGA Master para profesionales, en acero y aluminio. Su espesor de chapa sí como su exclusivo proceso de tratamiento térmico en 3 fases las provee de la resistencia y elasticidad necesarias para las soleras de más altas exigencias. Su acabado superficial evita la adherencia de arena, tierra... y facilita su mantenimiento.

New EGA Master shovels and spades for professional use, made in steel or aluminium. The thickness of their heads as well as their exclusive 3-step heat treatment process provide them with the necessary resistance and elasticity for the most demanding soils.

Nouveau: pelles et baches EGAMASTER pour l'usage professionnel, faites en acier ou aluminium. L'épaisseur aussi bien que leur procédé exclusif de traitement thermique en 3 étapes leurs fournissent la résistance et l'élasticité nécessaires pour les sols les plus exigeants.



Palas punta, cuadradas, de aluminio, palotes, etc... con amplia variedad de mangos; muleta, anilla o largos, ofrecen una completa gama para toda necesidad que deba afrontar el profesional.

Round or square, steel or aluminum, shovels or spades...with a very wide variety of handles: T-, V- or long handles, provide a perfect range where the demanding professional can choose whatever fits better his necessities.

Rond ou carré, acier ou aluminium, pelles ou baches... avec une grande variété de manches très grande de poignées : T -, V- ou des longues manches, EGAMASTER fournissent une gamme parfaite où le professionnel exigeant peut choisir celui qui s'adapte le mieux à ses nécessités.

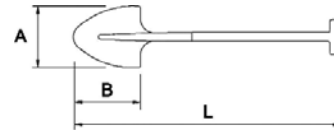

| COD | L | A | B | Kg. | |
|-------|------|-----|-----|------|---|
| 67185 | 1030 | 265 | 325 | 1,90 | 6 |
| 67186 | | 285 | 335 | 1,85 | |

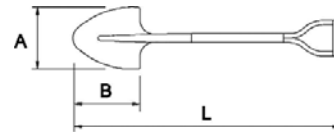

| COD | L | A | B | Kg. | |
|-------|------|-----|-----|------|---|
| 67187 | 1020 | 265 | 325 | 1,95 | 6 |
| 67188 | | 285 | 335 | | |

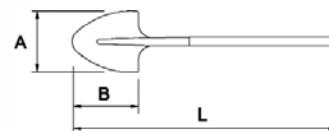

| COD | L | A | B | Kg. | |
|-------|------|-----|-----|------|---|
| 67189 | 1400 | 265 | 325 | 1,90 | 6 |



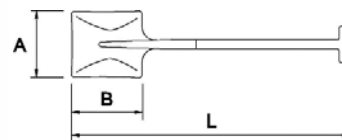

| COD | L | A | B | Kg. | |
|-------|------|-----|-----|------|---|
| 67196 | 1020 | 245 | 335 | 1,85 | 6 |
| 67197 | | 285 | 340 | 1,95 | |

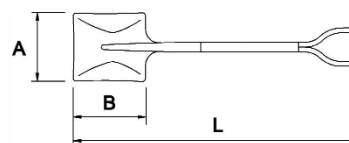

| COD | L | A | B | Kg. | |
|-------|------|-----|-----|------|---|
| 67198 | 1020 | 245 | 335 | 2,10 | 6 |
| 67199 | | 285 | 340 | 2,15 | |

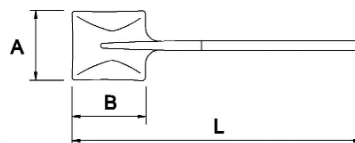

| COD | L | A | B | Kg. | |
|-------|------|-----|-----|------|---|
| 67200 | 1400 | 245 | 335 | 2 | 6 |
| 67201 | | 285 | 340 | 2,05 | |

aLUMINIUM

| COD | L | A | B | Kg. | |
|-------|------|-----|-----|------|---|
| 67208 | 1300 | 370 | 420 | 1,65 | 6 |

ALUMINIUM

| COD | L | A | B | Kg. | |
|-------|------|-----|-----|------|---|
| 67209 | 1620 | 370 | 420 | 1,65 | 6 |

ALUMINIUM

| COD | L | A | B | Kg. | |
|-------|-----|-----|-----|------|---|
| 67212 | 940 | 245 | 940 | 0,95 | 6 |

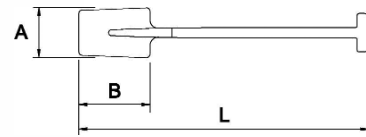

| COD | L | A | B | Kg. | |
|-------|-----|-----|-----|------|---|
| 67215 | 955 | 160 | 260 | 1,60 | 6 |

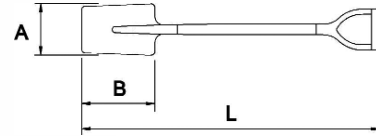

| COD | L | A | B | Kg. | |
|-------|-----|-----|-----|------|---|
| 67216 | 955 | 160 | 260 | 1,70 | 6 |

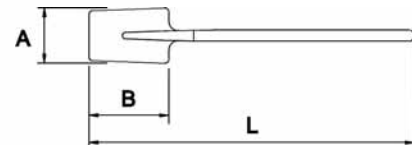

| COD | L | A | B | Kg. | |
|-------|------|-----|-----|------|---|
| 67218 | 1280 | 150 | 240 | 1,60 | 6 |

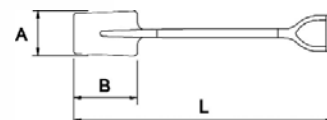

| COD | L | A | B | Kg. | |
|-------|------|-----|-----|------|---|
| 67219 | 1010 | 150 | 240 | 1,70 | 6 |

PALETAS / BRICKLAYERS / TRUELLES et couteaux / MAURERKELLEN / CAZZUOLE GEREEDSCHAP-VOOR DE STUKADOOR / COLHERES

HOJA DE ACERO ESPECIAL, VACIADA, PULIDA Y TEMPLADA. MANGO BARNIZADO.
ALLOY STEEL BLADE, BOUBLE POLISHED AND HARDENED. VARNISHED HANDLE.
ACIER SPECIAL DOUBLEMENT POLI ET TREMPE. MANCHE LAQUE.
KLINGE AUS SPEZIALSTAHL, PLANGESCHLIFFEN. POLIERT UND GEHÄRTET.
ACCIAIO SPECIALE LAMA PULITA IMPUGNATURA VERNICIATA.
BLAD VAN BUIGZAAM ROESTVRIJ STAAL, DUBBEL GEOPOLIJSJT EN GEHARD. GELAKTE HANGREEP.
FOLHA DE AÇO ESPECIAL POLIDA E TEMPERADA CABO ENVERNIZADO.

| COD | L mm | gr. | | |
|-------|---------|-----|---|---|
| 67000 | 105 | 120 | 6 | 1 |
| 67001 | 130 | 135 | | |



| COD | L mm | gr. | | |
|-------|---------|-----|---|---|
| 67017 | 105 | 120 | 6 | 1 |
| 67002 | 130 | 135 | | |



| COD | L mm | gr. | | |
|-------|-------------|-----|---|---|
| 67004 | 180x115x87 | 340 | 6 | 1 |
| 67003 | 190x130x100 | 385 | | |



MOD. CATALAN

| COD | L mm | gr. | | |
|-------|---------|-----|---|---|
| 67006 | 160 | 310 | 6 | 1 |
| 67005 | 170 | 325 | | |



MOD. MADRID

| COD | L mm | gr. | | |
|-------|---------|-----|---|---|
| 67007 | 140 | 165 | 6 | 1 |
| 67008 | 165 | 180 | | |
| 67009 | 180 | 220 | | |
| 67010 | 200 | 275 | | |
| 67019 | 230 | 330 | | |



MOD. SEVILLA

| COD | L mm | gr. |  |  |
|-------|---------|-----|---|---|
| 67011 | 190 | 325 | 6 | 1 |



MOD. ARABIA

| COD | L mm | gr. |  |  |
|-------|---------|-----|---|---|
| 67100 | 180 | 210 | 6 | 1 |
| 67101 | 200 | 250 | | |



MOD. ALICATADOR



| COD | L mm | gr. |  |  |
|-------|------------|-----|---|---|
| 67012 | 120x120x65 | 285 | 6 | 1 |



MOD. PORTUGAL

| COD | L mm | gr. |  |  |
|-------|------------|-----|---|---|
| 67013 | 250x130x65 | 330 | 6 | 1 |



| COD | L mm | gr. |  |  |
|-------|---------|-----|---|---|
| 67015 | 220x120 | 390 | 6 | 1 |
| 67014 | 250x130 | 480 | | |



| COD | L mm | gr. | | |
|-------|---------|-----|---|---|
| 67016 | 300x150 | 500 | 5 | 1 |

| COD | L mm | gr. | | |
|-------|---------|-----|---|---|
| 67018 | 275x115 | 400 | 5 | 1 |

| COD | L mm | gr. | | |
|-------|------|-----|----|---|
| 67020 | 30 | 65 | 12 | 1 |
| 67021 | 40 | | | |
| 67022 | 50 | | | |
| 67023 | 60 | | | |
| 67024 | 70 | | | |
| 67025 | 80 | 85 | | |
| 67026 | 90 | | | |
| 67027 | 100 | | | |



KIT 64 PCS.

| COD | L mm | PCS. |
|-------|------|------|
| 67029 | 30 | 8 |
| | 40 | |
| | 50 | |
| | 60 | |
| | 70 | |
| | 80 | |
| | 90 | |
| | 100 | |



PALANCA BOCA CURVA / PRY BAR / PINCE Á TALON FERME / BRECHSTANGE, GESCHLOSSER / LEVA UNGHIA CHIUSA / BREEKIJZER
ALAVANCA BOCA CURVA

| COD | size | L mm | Kg. | |
|-------|------|------|-----|---|
| 67202 | 6" | 150 | 0,1 | 6 |
| 67203 | 12" | 300 | 0,2 | |
| 67204 | 16" | 405 | 0,5 | |
| 67205 | 20" | 490 | 0,8 | |



| Composición / Composition | | | | |
|---------------------------|----------------------------|--|-----|---|
| 67206 | 67202, 67203, 67204, 67205 | | 1.6 | 1 |

PALANCA DE ENCOFRADOR / WRECKING BAR / PINCE A DECOFFRER / NAGELEISEN / LEVERINO CARPENTIERE / KOEVOET
ALAVANCA DE ENCOFRADOR

| COD | L | mm | gr. |
|-------|-----|----|------|
| 63261 | 12" | 14 | 250 |
| 63262 | 18" | 16 | 700 |
| 63263 | 24" | | 1400 |
| 63264 | 30" | | 2000 |
| 63265 | 36" | 18 | 2400 |
| 63266 | 42" | | 2750 |
| 63267 | 48" | 19 | 3100 |



PERFORADORAS / DRILLS / CAROTTEUSE A BETON / BOHRGERÄTE / PERFORATORE
PERFURADORAS

PERFOMATIC - 80

| COD | CAP. Ø | W | V | *R | R.P.M. | Kg. |
|-------|--------|------|-----|------------|----------|-----|
| 60226 | 12-80 | 1500 | 230 | 1/2" BSP | 950-2100 | 7,5 |
| 60227 | | | 110 | 1.1/4" UNC | | |

* 1/2": HEMBRA / FEMALE
1.1/4": MACHO / MALE



PERFOMATIC - 102

| COD | CAP. Ø | W | V | *R | R.P.M. | Kg. |
|-------|--------|------|-----|------------|----------|-----|
| 60228 | 12-102 | 1500 | 230 | 1/2" BSP | 950-2100 | 22 |
| 60229 | | | 110 | 1.1/4" UNC | | |

* 1/2": HEMBRA / FEMALE
1.1/4": MACHO / MALE



PERFOMATIC - 205

| COD | CAP. Ø | W | V | *R | R.P.M. | L | L | ⌒ | Kg. |
|-------|--------|------|-----|------------------------|--------|---|---|---|-------|
| 60230 | 12-205 | 2400 | 230 | 1/2" BSP 1.1/4" UNC | 600 | ● | | | 41,50 |
| 60231 | | | | | | ● | | | |
| 60232 | | | | | | ● | | ● | |
| 60233 | | | ● | | | | ● | | |
| 60234 | | | ● | | | | | | |
| 60235 | | | ● | | | | ● | | |
| 60236 | | | ● | | | | ● | | |
| 60237 | 110 | | ● | ● | | | | | |

* 1/2": HEMBRA / FEMALE
1.1/4": MACHO / MALE



PERFORADORAS / DRILLS / CAROTTEUSE A BETON / BOHRGERÄTE / PERFORATORE PERFORADORAS PERFORMATIC - 255

| COD | CAP. Ø | W | V | *R | R.P.M. | L | L | Ø | Kg |
|-------|--------|------|-----|------------------------|---------|---|---|---|----|
| 60238 | 12-255 | 2600 | 230 | 1/2" BSP 1.1/4" UNC | 460-900 | ● | ● | | 45 |
| 60239 | | | | | | ● | ● | | |
| 60240 | | | | | | ● | ● | ● | |
| 60241 | | | | | | ● | ● | ● | |
| 60242 | | | 110 | | | ● | ● | ● | |
| 60243 | | | | | | ● | ● | ● | |
| 60244 | | | | | | ● | ● | ● | |
| 60245 | | | | | | ● | ● | ● | |

PERFORMATIC - 300

| COD | CAP. Ø | W | V | *R | R.P.M. | L | L | Ø | Kg |
|-------|--------|------|-----|------------------------|---------|---|---|---|----|
| 60246 | 12-300 | 3300 | 230 | 1/2" BSP 1.1/4" UNC | 460-900 | ● | ● | | 48 |
| 60247 | | | | | | ● | ● | | |
| 60248 | | | | | | ● | ● | ● | |
| 60249 | | | | | | ● | ● | ● | |
| 60250 | | | 110 | | | ● | ● | ● | |
| 60251 | | | | | | ● | ● | ● | |
| 60252 | | | | | | ● | ● | ● | |
| 60253 | | | | | | ● | ● | ● | |

* 1/2": HEMBRA / FEMALE - 1.1/4": MACHO / MALE



CE *G12

broca de hormigon, segmentos de diamante sinterizados / sintered diamond drills for reinforced concrete drills / couronnes avec integration des segments diamantes pour le forage de betons armes / diamant-bohrkronen für stahl und beton / corona per cemento armato, punta diamantata sinterizzata / broca para cimento armado, segmentos de diamante sinterizados

PARA CORTE HUMEDO / FOR WET CUT / FORAGE A LEAU / ZUM NASSBOHREN / VOOR NAT BOREN / PER TAGLIO AD ACQUA
PARA CORTE HUMIDO

| COD A | Ø x L | R | COD B | Ø x L | R |
|-------|---------|--------------------------------|-------|---------|---------------------------|
| 64366 | 32x360 | 1.1/4" UNC HEMBRA FEMALE | 64355 | 12x120 | 1/2" BSP MACHO MALE |
| 64367 | 44x360 | | 64356 | 18x220 | |
| 64368 | 53x360 | | 64357 | 26x320 | |
| 64369 | 63x360 | | 64358 | 32x320 | |
| 64370 | 71x360 | | 64359 | 44x320 | |
| 64371 | 83x360 | | 64360 | 53x320 | |
| 64372 | 89x360 | | 64361 | 63x320 | |
| 64373 | 102x360 | | 64362 | 71x320 | |
| 64374 | 110x360 | | 64363 | 83x320 | |
| 64375 | 120x360 | | 64364 | 89x320 | |
| 64376 | 127x360 | | 64365 | 102x320 | |
| 64377 | 132x360 | | | | |
| 64378 | 150x360 | | | | |
| 64379 | 159x360 | | | | |
| 64380 | 166x360 | | | | |
| 64381 | 180x360 | | | | |
| 64382 | 202x360 | | | | |
| 64383 | 220x360 | | | | |
| 64384 | 244x360 | | | | |
| 64385 | 300x360 | | | | |



PARA CORTE SECO / FOR DRY CUT / FORAGE A SEC / ZUM TROCKENBOHREN / VOOR DROOG BOREN / PER TAGLIO ASCIUTO

| COD | Ø x L | R |
|-------|---------|---------------------------|
| 64386 | 32x300 | 1/2" BSP MACHO MALE |
| 64387 | 44x300 | |
| 64388 | 53x300 | |
| 64389 | 63x300 | |
| 64390 | 71x300 | |
| 64391 | 83x300 | |
| 64392 | 89x300 | |
| 64393 | 102x300 | |
| 64394 | 110x300 | |
| 64395 | 120x300 | |
| 64396 | 132x300 | |
| 64397 | 150x300 | |



SOPORTE FIJO / FIXED BRACKET / SUPPORT FIXE / STÄNDER / STAANDER / SUPPORTO FISSO / SUPORTE FIXO

| COD | | Kg |
|-------|----------------|----|
| 64398 | PERFOMATIC-205 | 22 |
| | PERFOMATIC-255 | |
| | PERFOMATIC-300 | |



SOPORTE RECLINABLE 90° / 90° RECLINABLE BRACKET / SUPPORT INCLINABLE 90° / STÄNDER 90° SCHWENKBAR / STAANDER 90° INSTELBAAR / SUPPORTO INCLINABILE 90° / SUPORTE INCLINAVEL 90°

| COD | | Kg |
|-------|----------------|----|
| 64399 | PERFOMATIC-205 | 35 |
| | PERFOMATIC-255 | |
| | PERFOMATIC-300 | |



VENTOSA / VACUUM BASE / VENTOUSE / VAKUUMPLATTE / VAKUUMPLAAT

| COD | | Kg |
|-------|----------------|-----|
| 64400 | PERFOMATIC-205 | 6,5 |
| | PERFOMATIC-255 | |
| | PERFOMATIC-300 | |



EXTENSION / VERLÄNGERUNG / VERLENGSTUK / ESTENSORE / EXTENÇÃO

| COD | A-B | Ø x L | Kg |
|-------|------------|--------|------|
| 64406 | 1.1/4" UNC | 40x150 | 1 |
| 64407 | | 40x210 | 1,3 |
| 64414 | 1/2" BSP | 30x200 | 0,80 |
| 64415 | | 30x260 | 1,1 |



MANGO / HANDLE / MANCHE / GRIFF / HANDGREEP / MANICO / PUNHO

| COD | | Kg |
|-------|----------------|-----|
| 64408 | PERFOMATIC-80 | 0,7 |
| | PERFOMATIC-102 | |



CONECTOR ADAPTADOR ROSCA / THREAD CONNECTION ADPTOR / CONNECTEUR ADAPTATEUR DE FILETAGE / ADAPTOR VERBINDUNGSADAPTER FÜR GEWINDE / ADDATTATORE CONNETTORE PER FILIERA / ADAPTADOR DE ROSCA

| COD | A-B | Kg |
|-------|-------------------------|-----|
| 64426 | * 1.1/4" UNC - 1/2" BSP | 0,4 |

* macho/male - hembra/female

| COD | A-B | Kg |
|-------|-------------------------|-----|
| 64610 | * 1/2" BSP - 1.1/4" UNC | 0,4 |

* macho/male - macho/male



MAQUINAS DE CORTE / CUTTING MACHINES / MACHINES DE COUPE / SCHNEIDMASCHINEN SNIJMACHINES / MACCHINE DA TAGLIO

CORTAVARILLAS ELECTROHIDRAULICO / ELECTROHYDRAULIC REBAR CUTTERS / COUPE BOULON ELECTRO-HYDRAULIQUE
ELEKTRO-HYDRAULISCHER STAHLDRAPHTSCHNEIDER / TAGLIABULLONI ELETTRICO / ELECTRISCH-HYDRAULISCHE
STAALDRAADSNIJDER / TESOURA CORTA VARÃO ELECTRO HIDRAULICA

REBARMATIC - 16 PORTABLE

| COD | V | CAP | W | | |
|--|----------|----------|------------------|-------|-----|
| 60274 | 110-240V | Ø4-Ø16mm | 690 | 64692 | 5,6 |
| Especificaciones técnicas / Technical specification / Détails techniques | | | | | |
| Capacidad / Capacity / Capacité | | | 4mm-16mm | | |
| Velocidad de corte / Cutting speed / Vitesse de coupe | | | 3 sg (16mm) | | |
| Cabezal giratorio / Revolving head / Tête pivotante | | | 360° | | |
| Batería / Battery / Piles | | | Ni-Mh DC 18V 3Ah | | |
| Baterías incluidas / Included batteries / Piles incluses | | | 2 pcs | | |
| Sistema electrohidráulico / Electrohydraulic system / Système electrohydraulique | | | ● | | |
| Tamaño estuche / Case dimensions / Dimension de l'étui | | | 415x390x135mm | | |
| Estuche metálico / Metallic case / Etui métallique | | | ● | | |
| Juego cuchillas / Blade set / Jeu de couteaux | | | 64692 | | |



REBARMATIC - 16

| COD | V | CAP | W | | |
|--|-----|----------|---------------|-------|---|
| 60270 | 230 | Ø4-Ø16mm | 690 | 64177 | 8 |
| 60272 | 110 | | | | |
| Especificaciones técnicas / Technical specification / Détails techniques | | | | | |
| Capacidad / Capacity / Capacité | | | 4mm-16mm | | |
| Velocidad de corte / Cutting speed / Vitesse de coupe | | | 3 sg (16mm) | | |
| Sistema electrohidráulico / Electrohydraulic system / Système electrohydraulique | | | ● | | |
| Tamaño estuche / Case dimensions / Dimension de l'étui | | | 460x150x115mm | | |
| Estuche metálico / Metallic case / Etui métallique | | | ● | | |
| Juego cuchillas / Blade set / Jeu de couteaux | | | 64177 | | |



REBARMATIC - 22

| COD | V | CAP | W | | |
|--|-----|----------|---------------|-------|----|
| 60271 | 230 | Ø4-Ø22mm | 850 | 64178 | 12 |
| 60273 | 110 | | | | |
| Especificaciones técnicas / Technical specification / Détails techniques | | | | | |
| Capacidad / Capacity / Capacité | | | 4mm-22mm | | |
| Velocidad de corte / Cutting speed / Vitesse de coupe | | | 3 sg (22mm) | | |
| Sistema electrohidráulico / Electrohydraulic system / Système electrohydraulique | | | ● | | |
| Tamaño estuche / Case dimensions / Dimension de l'étui | | | 420x130x150mm | | |
| Estuche metálico / Metallic case / Etui métallique | | | ● | | |
| Juego cuchillas / Blade set / Jeu de couteaux | | | 64178 | | |



antes / before / avant



después / after / après



TRONZADORA DISCO ABRASIVO / CUT-OFF MACHINE / MEULEUSE A DISQUES ABRASIFS / TRENNSCHLEIFMASCHINE
 METALAFKORTMACHINES / MACCHINA DA TAGLIO / CORTADORA DE DISCO ABRASIVO

| COD | Ø | V | W | R.P.M. | Kg | |
|-------|-----|-----|------|--------|----|-------|
| 60254 | 355 | 230 | 2300 | 3900 | 19 | 85118 |
| 60255 | | 110 | | | | |



SIERRA PARA LADRILLOS CON MESA / BENCH BRICKS CUT-OFF MACHINE / SCIE A BRIQUES DA TABLE /
 TISCHKREISSÄGE FÜR BACKSTEIN / METAALAFKORTZAAG-TAFELMODEL / MACCHINA DA TAGLIO CON BANCO /
 SERRA PARA CORTAR MOSAICOS CON MESA

| COD | Ø | CAP | V | W | R.P.M. | Kg |
|-------|-----|-------------|-----|------|--------|----|
| 60256 | 355 | 255x406x127 | 230 | 1650 | 3500 | 21 |
| 60257 | | | 110 | | | |

REFRIGERADA POR AGUA / WATER-COOLED / REFRROIDISEUR D'EAU / WASSERKÜHLED
 ACQUA REFFRIGERATA / WATERGEKOELD



SIERRA PARA LADRILLOS / BRICKS CUT-OFF SAW / SCIE A BRIQUES / KREISSÄGE FÜR BACKSTEIN / METAALAFKORTZAAG
 MACCHINA DA TAGLIO / SERRA PARA CORTAR MOSAICOS

| COD | Ø | CAP | V | W | R.P.M. | Kg |
|-------|-----|-------------|-----|------|--------|----|
| 60258 | 355 | 255x406x127 | 230 | 1650 | 3500 | 11 |
| 60259 | | | 110 | | | |

REFRIGERADA POR AGUA / WATER-COOLED / REFRROIDISEUR D'EAU / WASSERKÜHLED
 ACQUA REFFRIGERATA / WATERGEKOELD





*MEDICION Y DETECCION / MEASURING AND DETECTION / MESURE ET
DÉTECTION / MESSUNG UND DETEKTION / MISURAZIONE E RILEVAMENTO
METEN EN OPSPORING / MEDIÇÃO E DETECÇÃO*

FLEXOMETROS MEASURING TAPES METRES

1 BMAT *

Carcasa Bimaterial ABS+Elastómero resistente al choque y a la abrasión.
ABS+Elastomer antishock and antiabrasion bimaterial case.
Boîtier bimatière ABS + élastomère résistant aux chocs et à l'abrasion.

CHROME *

Carcasa cromada.
Chromed Plated Case.
Boîtier chromé.

Carcasas Antichoque de duración ilimitada.
Unlimited life antishock cases.
Boîtier anti-chocs à durée illimitée.

2 STOPS *

Doble acción de bloqueo y freno para la máxima comodidad de utilización y seguridad.
Doble action safety blocking and braking for maximum comfort.
Système double-action de freinage et de blocage pour un meilleur confort d'utilisation.

5

Muelle de retorno Extrafuerte con sistema de cambio de cinta RapidChange.
ExtraResistant returning spring equipped with RapidChange quick blade-replacing system.
Ressort de rembobinage ultra-renforcé avec système de remplacement de ruban Ultra-rapide.



3

NYLON *

Recubrimiento de nylon MASTER 15 VECES más resistente a la abrasión y a la oxidación. Antiadherente y antireflectante.
MASTER nylon coating , 15 times more resistant against abrasion and rust. Dirt anti-adherence and non-reflecting.
Revêtement de nylon MASTER 15 fois plus résistant à l'abrasion et à l'oxydation. Anti-adhérente et anti-réfléchissante.

URAR *

Recubrimiento 10 VECES más resistente a la abrasión y a la oxidación. Antiadherente y antireflectante.
10 times more resistant against abrasion and rust. Dirt anti-adherence and non-reflecting.
Revêtement 10 fois plus résistant à l'abrasion et à l'oxydation. Anti-adhérente et anti-réfléchissante.

INOX *

Cinta y todos los componentes metálicos de acero inoxidable para trabajos ambientales de máxima humedad.
Tape and all metallic components made in Stainless Steel to work under the most humid environmental conditions.
Ruban et tous composants métalliques en acier inoxydable pour travaux en environnements humides.

DOUBLE MARK *

Doble marcaje incluido uno en la parte posterior de la cinta para mediciones verticales.
Double marking, including another one in the back of the tape for vertical measurements.
Double marquage y compris un vertical sur la partie postérieure de la bande pour permettre des mesures verticales.

Graduación continua y de fácil visión para entornos lejanos o poco iluminados.
Continuous and easy-reading scale for long distances or low light environments.
Graduation continue et à visible à longue distance et avec peu de luminosité.

Cinta mate / Matt tape / Ruban mat

Cintas de acero de 0,11 mm de espesor de la mayor calidad y resistencia a la flexión, recubiertas con las más avanzadas técnicas antirreflexión, antiabrasión, antiadherencia y antioxidación.
Bending resistant and highest quality 0,11 mm thickness steel blades, equipped with the most advanced techniques in antireflection, antiabrasion, antiadherence and antirust coating.
Ruban en acier de 0,11mm d'épaisseur première qualité de grande résistance, recouvert avec les meilleures techniques anti-réfléchissantes, anti-abrasion, anti-adhérence et anti-oxydation.

MAGNET C *

Potente uña magnética
Powerful Magnetic Hook
Onglet magnetique puissant

Uñas reforzadas antichoque en todos los modelos para los trabajos más exigentes.
Antishock reinforced hooks for the toughest jobs.
Crochets renforcés anti-chocs sur tous les modèles, pour les utilisations les plus exigeantes.

Características adicionales específicas en cada modelo
Additional specifications for each model.
Caractéristiques additionnelles spécifiques à chaque modèle

Hoja de acero templada: Acero carbono o Acero inoxidable.
Tempered steel spring blade: Carbon steel or Stainless steel.
Feuille d'acier tendre : acier-carbone ou acier inoxydable.

Pintura Antiabrasiva: Amarillo / Plateado
Anticorrosive Painting: Yellow / Silver
Peinture anti-corrosive : jaune / argent

Estampación de graduación continua
Continuous printed graduation
Graduation continue pressée

Recubrimiento antiabrasivo transparente
Anticorrosive transparent coating
Revêtement anti-corrosion transparent

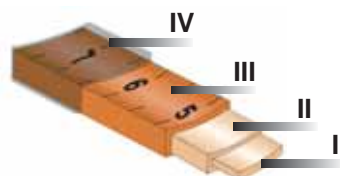

FLEXOMETROS / MEASURING TAPES / METRES / STAHLROLLBANDMASSE / ROLMAAT FLESSOMETRI / FITAS METRICAS

PLATINUM Q

| COD | CLIP | BL. | DF. |
|-------|--------------|----------|-----|
| 65706 | 3mx16mm | | 110 |
| 65707 | 5mx19mm | mm | 180 |
| 65708 | 8mx25mm | | 355 |
| 65721 | 3m/10'x16mm | | 110 |
| 65722 | 5m/16'x 19mm | mm/inch. | 180 |
| 65723 | 8m/26'x25mm | | 355 |



15 veces más resistente a la abrasión y oxidación
15 times more resistant against abrasion and rust
15 fois plus résistant contre l'abrasion et la rouille

DOUBLE MARK



NEW

PLATINUM Q MAGNET

| COD | CLIP | BL. | DF. |
|-------|--------------|----------|-----|
| 65709 | 5mx25mm | mm | 210 |
| 65710 | 8mx25mm | | 355 |
| 65724 | 5m/16'x25mm | mm/inch. | 210 |
| 65725 | 8m/26'x 25mm | | 355 |



15 veces más resistente a la abrasión y oxidación
15 times more resistant against abrasion and rust
15 fois plus résistant contre l'abrasion et la rouille

INOX

| COD | CLIP | BL. | DF. |
|-------|-------------|----------|-----|
| 65162 | 3mx16mm | mm | 110 |
| 65163 | 5mx19mm | | 210 |
| 65355 | 3m/10'x16mm | mm/inch. | 110 |
| 65356 | 5m/16'x 9mm | | 210 |



Todos los componentes metálicos de Acero Inoxidable
All metallic components made in Stainless Steel
Tous les composants métalliques faits en acier inoxydable

15 veces más resistente a la abrasión y oxidación
15 times more resistant against abrasion and rust
15 fois plus résistant contre l'abrasion et la rouille



FLEXOMETROS / MEASURING TAPES / METRES / STAHLROLLBANDMASSE / ROLMAAT FLESSOMETRI / FITAS METRICAS

ROBUST

| COD | CLIP | BL. | UF. | |
|-------|-------------|-----|-----|----|
| 65164 | 3mx19mm | | 110 | 12 |
| 65165 | 5mx25mm | ● | 225 | 10 |
| 65166 | 8mx30mm | ● | 420 | |
| 65357 | 3m/10'x19mm | | 110 | 12 |
| 65358 | 5m/16'x25mm | ● | 225 | 10 |
| 65359 | 8m/26'x30mm | ● | 420 | |



15 veces más resistente a la abrasión y oxidación
15 times more resistant against abrasion and rust
15 fois plus résistant contre l'abrasion et la rouille

ROBUST MAGNET

| COD | CLIP | BL. | UF. | |
|-------|-------------|-----|-----|----|
| 65167 | 5mx25mm | ● | 225 | 10 |
| 65360 | 5m/16'x25mm | ● | 225 | 10 |



15 veces más resistente a la abrasión y oxidación
15 times more resistant against abrasion and rust
15 fois plus résistant contre l'abrasion et la rouille



CHROME

| COD | CLIP | BL. | UF. | |
|-------|---------|-----|-----|----|
| 65168 | 3mx16mm | | 120 | 12 |
| 65169 | 5mx19mm | ● | 240 | 10 |
| 65170 | 8mx25mm | ● | 330 | |



10 veces más resistente a la abrasión y oxidación
10 times more resistant against abrasion and rust
10 fois plus résistant contre l'abrasion et la rouille

RALLYE

| COD | CLIP | BL. | UF. | |
|-------|-------------|-----|-----|----|
| 65171 | 2mx13mm | | 105 | 12 |
| 65172 | 3mx16mm | | 120 | |
| 65173 | 5mx19mm | ● | 200 | 10 |
| 65174 | 8m/x25mm | ● | 330 | |
| 65361 | 2m/6'x13mm | | 105 | 12 |
| 65362 | 3m/10'x16mm | | 120 | |
| 65363 | 5m/16'x19mm | ● | 200 | 10 |
| 65364 | 8m/26'x25mm | ● | 330 | |



10 veces más resistente a la abrasión y oxidación
10 times more resistant against abrasion and rust
10 fois plus résistant contre l'abrasion et la rouille

2 STOPS

CINTAS METRICAS / LONG MEASURING TAPES / METRES RUBANS / STAHLBANDMASS MIT GRIFF LANG MEETLINT MET HANDGREEP / BINDELLA / FITAS METRICAS LONGAS

*MODELOS EN CARCASA BIMATERIAL ANTICHOQUE (BIMAT) EQUIPADOS CON SISTEMAS DE RECOGIDA RAPIDA DE CINTA ANTIATASCO.
 *ANTISHOCK BIMATERIAL CASES (BIMAT) EQUIPPED WITH ANTI-BLOCKAGE FAST REWINDING SYSTEM.
 *MODELES AVEC ANTI-CHOCS BI-MATIERE (BIMAT) EQUIPES D'UN SYSTEME DE REMBOBINAGE RAPIDE ANTI-BLOCAGE.

CINTA DE ACERO / STEEL TAPE / RUBAN D'ACIER / STAHLBANDMASS / STAAL BANDMETER / NASTRO IN ACCIAIO
 FITA METRICA DE AÇO

| COD | | | | | |
|-------|----------|----|-----|---|---|
| 65175 | 10m/13mm | mm | 440 | ● | 6 |
| 65176 | 20m/13mm | | 520 | | |
| 65177 | 30m/13mm | | 660 | | |



NORMAL AMARILLO LACADO
 NORMAL YELLOW LACQUERED
 JAUNE NORMAL LAQUE



CINTA DE FIBRA DE VIDRIO / FIBER GLASS TAPE / RUBAN EN FIBRE DE VERRE / BANDMASS GLASFASER / FIBERGLAS BANDMETER
 NASTRO IN FIBRA DI VETRO / FITA METRICA DE FIBRA DE VIDRO

| COD | | | | | |
|-------|----------|----------|-----|---|---|
| 65178 | 10m/13mm | mm | 360 | ● | 6 |
| 65179 | 20m/13mm | | 400 | | |
| 65180 | 30m/13mm | | 440 | | |
| 65181 | 50m/13mm | | 760 | | |
| 65365 | 10m/13mm | mm/inch. | 360 | ● | 6 |
| 65366 | 20m/13mm | | 400 | | |
| 65367 | 30m/13mm | | 440 | | |
| 65368 | 50m/13mm | | 760 | | |



FIBRA DE VIDRIO
 FIBER GLASS
 FIBRE DE VERRE



SONDA / TANK DIPPING TAPE / SONDE / EINTAUCHMASSBAND / TANK BANDMETER

Cinta para mediciones en inmersión en tanques oleaginosos / Tank dipping tape for oleaginous tanks
 Rubans pour mesures immergées en réservoirs oléagineux.

| COD | | | | |
|-------|----------|----|-----|---|
| 65182 | 10m/13mm | mm | 500 | 1 |
| 65183 | 20m/13mm | | 600 | |
| 65184 | 30m/13mm | | 700 | |



ALUMINIO
 ALUMINIUM

CINTA NEGRA
 BLACK TAPE
 BANDE NOIRE



CINTA DE ACERO / STEEL TAPE / RUBAN D'ACIER / STAHLBANDMASS / STAAL BANDMETER / NASTRO IN ACCIAIO
 FITA METRICA DE AÇO

Gama de cinta de tipo pistola ergonómica de fácil manejo / Ergonomic Gun Type Long Tape
 Gamme de ruban revolver ergonomiques pour un usage facilité.

| COD | | | | |
|-------|----------|----|-----|---|
| 65185 | 10m/13mm | mm | 400 | 1 |
| 65186 | 20m/13mm | | 500 | |
| 65187 | 30m/13mm | | 600 | |
| 65188 | 50m/13mm | | 700 | |



ALUMINIO
 ALUMINIUM

NORMAL AMARILLO LACADO
 NORMAL YELLOW LACQUERED
 JAUNE NORMAL LAQUE



NIVELES / SPIRIT LEVELS / NIVEAUX / WASSERWAAGEN / WATERPASSEN / LIVELLE / NIVEIS

TUBULAR DE ALTA PRECISION 0,5MM/M / 0,5MM/M HIGH ACCURACY SPIRIT LEVEL / NIVEAU TUBULAIRE DE HAUTE PRECISION 0,5MM/M / PROFI WASSERWAGEN 0,5MM/M AKKURAT / PROFI WATERPAS 0,5MM/M METING / LIVELLA TUBOLARE AD ALTA PRECISIONE 0,5MM/M / NIVEL TUBULAR DE ALTA PRECISÃO 0,5MM/M

Alta precisión / High accuracy / Haute precision: **0,5mm/m**
 Burbujas antichoque / Antischock vials / Fioles antichocs
 Asas de fácil manejo / Easy-use handles / Anses pour maniement aise

| COD | L | | mm/m | | |
|-------|------|---|------|-----|---|
| 65191 | 300 | 3 | 0,5 | 200 | 6 |
| 65192 | 400 | | | 240 | |
| 65193 | 500 | | | 300 | |
| 65194 | 600 | | | 360 | |
| 65195 | 800 | | | 460 | |
| 65196 | 1000 | | | 540 | |
| 65197 | 1200 | | | 620 | |



TUBULAR MAGNETICO DE PRECISION 1MM/M / 1MM/M ACCURACY MAGNETIC SPIRIT LEVEL / NIVEAU TUBULAIRE DE PRECISION 1MM/M MAGNETIQUE / MAGNETISCHE WASSERWAGEN 1MM/M ACCURAT / WATERPAS MAGNETISCH 1MM/M METING / LIVELLA MAGNETICA TUBOLARE DI PRECISIONE 1MM/M / NIVEL TUBULAR DE PRECISÃO 1MM/M MAGNETICO

Precisión / Accuracy / Precision: **1mm/m**
 Burbujas antichoque / Antischock vials / Fioles antichocs
 Magnético para sujeción a superficies metálicas / Magnetic for fixing to metallic surfaces / Magnetique pour accroche sur superficies metalliques

MAGNET C

| COD | L | C | mm/m | | |
|-------|------|---|------|------|---|
| 65145 | 400 | ● | 1 | 230 | 6 |
| 65146 | 500 | | | 250 | |
| 65147 | 600 | | | 310 | |
| 65198 | 800 | | | 700 | |
| 65199 | 1000 | | | 900 | |
| 65200 | 1200 | | | 1005 | |
| 65201 | 1500 | | | 1250 | |



TUBULAR DE PRECISION 1MM/M ESCALA GRADUADA / GRADUATED SCALE 1MM/M ACCURACY SPIRIT LEVEL / NIVEAU TUBULAIRE DE PRECISION 1MM/M ECHELLE GRADUEE / GRADUAL WASSERWAGEN 1MM/M ACCURAT / WATERPAS 1MM/M METING / LIVELLA TUBOLARE DI PRECISIONE CON SCALA GRADUATA 1MM/M / NIVEL TUBULAR DE PRECISÃO 1MM/M ESCALA GRADUADA

Precisión / Accuracy / Precision: **1mm/m**
 Burbujas antichoque / Antischock vials / Fioles antichocs
 Escala graduada / Graduated scale base / Echelle graduee

| COD | L | | mm/m | | |
|-------|------|---|------|-----|---|
| 65148 | 300 | 3 | 1 | 140 | 6 |
| 65149 | 400 | | | 180 | |
| 65150 | 500 | | | 240 | |
| 65151 | 600 | | | 300 | |
| 65152 | 700 | | | 340 | |
| 65153 | 800 | | | 400 | |
| 65154 | 1000 | | | 480 | |



TRAPEZOIDAL / BRIDGE TYPE / NIVEAU TRAPEZOIDAL / EINSOHLIGE WASSERWAGEN / WATERPAS / LIVELLA TRAPEZOIDALE / NIVEL TRAPEZOIDAL

MAGNET C

| COD | L | mm/m | Burbujas antichoque | Fioles anticocs |
|-------|-----|------|---------------------|-----------------|
| 65293 | 400 | 1 | 2 | 250 |
| 65294 | 500 | | | 320 |
| 65295 | 600 | | | 400 |

Precisión / Accuracy / Precision: 1mm/m Burbujas antichoque / Antischock vials / Fioles anticocs



| COD | L | mm/m | Burbujas antichoque | Fioles anticocs |
|-------|-----|------|---------------------|-----------------|
| 65155 | 400 | 1 | 2 | 250 |
| 65156 | 500 | | | 320 |
| 65157 | 600 | | | 400 |
| 65202 | 800 | | | 530 |

Precisión / Accuracy / Precision: 1mm/m Burbujas antichoque / Antischock vials / Fioles anticocs



TORPEDO / TORPEDO WASSERWAGEN / TORPEDO WATERPAS / LIVELLA TORPEDO / NIVEL TORPEDO

| COD | L | mm/m | Burbujas antichoque | Fioles anticocs |
|----------|-----|------|---------------------|-----------------|
| A- 65158 | 220 | 1 | 3 | 110 |
| B- 65159 | | | | 70 |

Precisión / Accuracy / Precision: 1mm/m Burbujas antichoque / Antischock vials / Fioles anticocs



PLOMADA TRAZADORA / CHALK LINE REEL / CORDEAU RECHARGEABLE / SCHLAGSCHNURROLLER / GESSO TRACCIATORE / SLAGLIJNMOLEN / LINHAS DE TRAÇAR

| COD | mm/m | Fioles anticocs |
|-------|--------|-----------------|
| 65203 | 15mts. | 3 |
| 65204 | 30mts. | |



| COD | Fioles anticocs |
|-------|-----------------|
| 64418 | 3 |
| 64419 | |



MEDIDORES Y NIVELES LÁSER / MEASURERS AND LASER LEVELS / MESURES ET NIVEAUX LASER / VERMESSUNG UND LINIENLASER / METRI E LIVELLE / METERS EN LASERRICHTER / MEDIDORES E NÍVEIS LASER

NIVEL LASER ANGULAR / LASER ANGLE MACHINE / NIVEAU D'ANGLE LASER / WINKEL LASER / LIVELLE LASER ANGOLARI / HOEKLASERRICHTER / NÍVEL LASER ANGULAR

| COD | Fioles anticocs |
|-------|-----------------|
| 65511 | 1 |





Funciones / Functions / Fonctions:

- Útil para fijación o alineación de objetos / Useful for fixing or aligning objects / Utile pour le centrage ou l'aligination des objets.
- Adecuado para búsqueda de orientaciones en construcción y para trabajos en madera / Suitable for finding orientations in construction and for wood working / Adéquat pour la recherche du sens et de l'orientation dans la construction.

| Especificaciones técnicas / Technical specification / Détails techniques | |
|--|-------------|
| Fuente alimentación / Power supply / Source d'alimentation | 4,5V DC |
| Precisión angular / Accuracy of angle measuring / Précision angulaire | ± 1° |
| Longitud de onda / Laser wavelength / Longueur d'ondes | 650nm |
| Potencia del láser / Output power / Puissance du Laser | ≤ 1mW |
| Tipo de láser / Laser class / Type de Laser | 2 |
| Tª trabajo / Operating temperature / Température de travail | -5°C - 40C° |



DETECTOR MULTIFUNCIÓN / MULTI-FUNCTION DETECTOR / DÉTECTEUR MULTI-FONCTIONS / MULTI FUNKTIONELLE DETECTOR RILEVATORE MULTIFUNZIONE / MULTI-FUNZIONELE DETECTOR / DETECTOR MULTIFUNÇÕES

| | | | | | |
|--------------|---|---|---|---|--|
| COD |  |  |  |  |  |
| 65508 | 0,45-15m | 20mm | 300 | 6 | 1 |

Funciones / Functions / Fonctions:

- Puntero láser para fijación o alineación de objetos / Laser beam to fix or align objects / Point Laser pour fixer ou aligner un objet.
- Medidor de distancias entre objetos / Distance measurer between objects / Calculateur de distance entre objets.
- Cálculo de áreas y volúmenes / Square and cubic measurement calculator / Calcul d'aire et de volume.
- Detector de conductos metálicos y cables eléctricos. en el interior de paredes u otros objetos / Detector of metal pipelines and electrical wires inside walls or other objects / Détecteur de conduits métalliques et de câbles électriques dans les murs ou objets.
- Medidor de temperatura ambiente / Ambient temperature measurer / Calculateur de température ambiante.

Especificaciones técnicas / Technical specification / Détails techniques

| | |
|--|------------|
| Fuente alimentación / Power supply / Source d'alimentation | 9V DC |
| Alcance / Reach / Distance | 0,45 -15m |
| Precisión / Precision / Précision | 99,5% |
| Resolución / Resolution / Résolution | 5mm |
| Longitud de onda / Laser wavelength / Longueur d'onde | 650nm |
| Potencia del láser / Output power / Puissance du Laser | < 1mW |
| Tipo de láser / Laser class / Type de Laser | 2 |
| Máxima profundidad de detección / Max. detection depth / Profondeur maximum de détection | 20mm |
| Tª trabajo / Operating temperature / Température de travail | 0°C - 40°C |



CE *G12

MEDIDOR DE DISTANCIAS / DISTANCE DETECTOR / MESURE DE DISTANCE / DISTANZ DETECTOR / MISURATORE A DISTANZA AFSTANDDETECTOR / MEDIDOR DE DISTANCIAS

| | | | | |
|--------------|---|---|---|--|
| COD |  |  |  |  |
| 65509 | 0,4-13m | 300 | 6 | 1 |

Funciones / Functions / Fonctions:

- Medidor de distancias entre objetos / Distance measurer between objects / Calculateur de distances entre objets.
- Cálculo de áreas y volúmenes / Square and cubic measurement calculator / Calculateur d'aire et de volume.
- Función calculadora para operar con mediciones / Calculator function to work with the measurements / Fonction calculatrice de mesures.

Especificaciones técnicas / Technical specification / Détails techniques

| | |
|---|------------|
| Fuente alimentación / Power supply / Source d'alimentation | 9V DC |
| Alcance / Detect distance / Distance | 0,4 -13m |
| Precisión / Precision / Précision | 99,5% |
| Resolución / Resolution / Résolution | 5mm |
| Tª trabajo / Operating temperature / Température de travail | 0°C - 40°C |



CE *G12

DETECTOR DE INCRUSTADOS / STUD FINDER / DETECTEUR D'OBJETS INCRUSTÉS / NÄGELSUCHER RILEVATORE DI VITI PRIGIONIERE / NAGELDETECTOR / DETECTOR DE INCRUSTADOS

| | | | | |
|--------------|---|---|---|--|
| COD |  |  |  |  |
| 65510 | 20mm | 200 | 6 | 1 |

Funciones / Functions / Fonctions:

- Detector de conductos metálicos en el interior de paredes u otros objetos / Detector of metal pipelines and electrical wires inside walls or other objects / Détecteur de conduits métalliques à l'intérieur des murs ou des objets.
- Detector de cables eléctricos en el interior de paredes u otros objetos / Detector of metal pipelines and electrical wires inside walls or other objects / Détecteur de câbles électriques à l'intérieur des murs et objets.
- Detector de vigas de madera a través de placas de yeso o madera / Wood rafter detector through plaster or wooden boards / Détecteur de poutres en bois à travers les plaques de plâtre et de bois.

Especificaciones técnicas / Technical specification / Détails techniques

| | |
|--|------------|
| Fuente alimentación / Power supply / Source d'alimentation | 9V DC |
| Máxima profundidad de detección / Max. detection depth / Profondeur maximum de détection | 20mm |
| Tª trabajo / Operating temperature / Température de travail | 0°C - 40°C |



CE *G12

NIVEL LASER AUTONIVELANTE PROFESIONAL / PROFESSIONAL SELF-LEVELING LASER LEVEL / NIVEAU LASER Á AUTO NIVE-
 LAGE PROFESSIONNEL / PROFESSIONELLE SELBSTNIVILIERENDE LINIENLASER / LIVELLA AUTOLIVELLANTE PROFESSIONALE
 PROFESSIONELE ZELFINSTELBARE LASERRICHTER / NIVEL LASER AUTONIVELANTE PROFISSIONAL

Características:

- Equipado con un preciso sensor electrónico de alta calidad para la autonivelación.
- Rápida y automática autonivelación tanto para trabajos en horizontal como en vertical.
- Modos automático y manual opcionales.
- Modos rotatorio, barrido y puntual opcionales. Velocidad de rotación variable. Giro a izquierda y derecha.
- Funciones de autochequeo y autonivelación disponibles para el usuario. También las opciones de alta y baja precisión para diferentes usos.
- Equipado con control remoto para manejar la mayoría de funciones del láser.

Features:

- Equipped with a high quality and accurate electronic sensor.
- Quick and automatic self-leveling for horizontal and vertical works.
- Auto mode / manual mode option.
- With rotating, scan and spot function, rotation speed variable options. Left and right turn.
- Self-checking and self-calibration function for user's convenience. High accuracy and low accuracy options for different uses.
- Fitted with remote control to operate most functions on the laser.

Caractéristiques:

- Doté d'un sensor électronique précis et de haute qualité pour l'auto-nivelage.
- Auto-nivelage rapide et automatique tant pour le travail horizontal que vertical.
- Mode automatique ou manuel en option.
- Mode rotatif, scanné, et pointillé en option. Vitesse de rotation variable. Rotation à gauche et à droite.
- Fonctions anti-chocs et auto-nivelage disponibles pour l'utilisateur. Aussi option de grande ou moyenne précision pour différentes utilisations.
- Doté d'un contrôle télécommande pour pouvoit utiliser le maximum de fonctions laser.



Especificaciones técnicas / Technical specification / Détails techniques

| | |
|--|--|
| Fuente alimentación / Power supply / Source d'alimentation | 4x1,5V D DC / 5x1,2V DC Ni-H bat. |
| Autonomía / Operating time / Autonomie | 40h / 10h |
| Longitud de onda / Laser wavelength / Longueur d'onde | 635nm |
| Potencia del láser / Output power / Puissance du Laser | < 1mW |
| Tipo de láser / Laser class / Type de Laser | 2 |
| Precisión / Precision / Précision | hor. ± 0,1 mm/m vert. ± 0,2 mm/m |
| Distancia de trabajo / Working distance / Distance de travail | 20m |
| Con detector / With detector / Avec détecteur | 200m |
| Velocidad rotación / Rotation speed / Vitesse de rotation | 0/5/200/420 r.p.m. |
| Rango autonivelación / Self-leveling range / Précision de l'autonivelage | ± 5° |
| Sistema aviso / Warning system / Système d'alerte | luz parpadeante / flashing light / lumière intermitante |
| Angulo de trabajo / Speed angle / Angle de travail | 5° / 15° / 30° / 360° |
| Tª trabajo / Operating temperature / Température de travail | -10°C - 50°C |
| Resistente al agua / Water proof / Etanchéité | IP x 6 |
| Peso / Weight / Poids | 2,5 Kg |

EQUIPADO CON / EQUIPED WITH / EQUIPE:

Maleta plástico / Blow mould case / Malette plastique
 Control remoto / Remote control / Télécommande
 Cargador / Charge / Chargeur
 Base / Trestle / Base
 Detector / Detector / Détecteur
 Gafas / Googles / Lunettes



NIVEL LASER ROTATORIO PROFESIONAL / PROFESSIONAL ROTATORY LASER LEVEL / NIVEAU LASER ROTATIF PROFESSIONNEL / PROFESSIONELLE ROTIERENDE LINIENLASER / LIVELLA GIREVOLE PROFESSIONALE / PROFESSIONELE ROTERENDE LASERRICHTER / NIVEL LASER ROTATIVO PROFESIONAL

Características:

- Permite nivelaciones horizontales y verticales.
- Fácil de nivelar y manejar.
- Velocidad de rotación ajustable.
- Modos rotatorio, barrido y puntual opcionales.
- Equipado con control remoto para manejar la mayoría de funciones del láser.
- Equipado con detector para el marcado exacto de la medición a grandes escalas.
- Resistente al agua y al polvo.

Features:

- Suitable for horizontal and vertical levelings.
- Easy to level and operate.
- Adjustable rotating speed.
- With rotating, scan and spot function options.
- Fitted with remote control to operate most functions of the laser.
- Equipped with detector to get exact measurements in large distances.
- Water proof and dust proof.

Caractéristiques:

- Permet de niveler horizontalement et verticalement.
- Facilité de mise à niveau et d'utilisation.
- Vitesse de rotation réglable.
- Modes giratoires continu et discontinu en option.
- Doté d'un contrôle télécommande, pour utiliser la majorité des fonctions Laser.
- Doté d'un détecteur pour le marquage exact de la mesure à grande échelle.
- Résistant à l'eau et à la poussière.

COD

65513



Especificaciones técnicas / Technical specification / Détails techniques

| | |
|---|-------------------------------------|
| Fuente alimentación / Power supply / Source d'alimentation | 4 x1,5V AA DC |
| Autonomía / Operating time / Autonomie | 10h cont. |
| Longitud de onda / Laser wavelength / Longueur d'onde | 635nm |
| Potencia del láser / Output power / Puissance du Laser | < 1mW |
| Tipo de láser / Laser class / Type de Laser | 2 |
| Precisión / Precision / Précision | hor. ± 0,2 mm/m vert. ± 0,3 mm/m |
| Distancia de trabajo / Working distance / Distance de travail | 10m |
| Con detector / With detector / Avec détecteur | 100m |
| Velocidad rotación / Rotation speed / Vitesse de rotation | 100 -300 r.p.m. |
| Tª trabajo / Operating temperature / Température de travail | 0°C - 40°C |

EQUIPADO CON / EQUIPED WITH / EQUIPE:

Maleta plástico / Blow mould case / Malette plastique
Control remoto / Remote control / Télécommande
Base / Trestle / Base
Detector / Detector / Détecteur
Gafas / Goggles / Lunettes



NIVEL LASER AUTONIVELANTE STANDARD / STANDARD SELF-LEVELING LASER LEVEL / NIVEAU LASER AUTO-RÉGLABLE
 STANDARD SELBSTNIVILIERENDE LINIENLASER / LIVELLA AUTOLIVELLANTE STANDARD / STANDARD ZELFINSTELBARE
 LASERRICHTER / NÍVEL LASER AUTONIVELANTE STANDARD

| |
|--|
| PROYECCIÓN LÁSER HORIZONTAL / HORIZONTAL LASER LINE / LASER HORIZONTAL |
| PROYECCIÓN LÁSER VERTICAL / VERTICAL LASER LINE / LASER VERTICAL |
| PROYECCIÓN CRUCETA / LASER CROSS / LASER EN CROIX |
| BASE ROTATORIA GRADUADA EN SUS 360° ROTATORY BASE PROVIDES 360° ANGLE REFERENCE POINTS BASE TOURNANTE GARDUÉE SUR 360° |

COD

65514



CE *G12

| Especificaciones técnicas / Technical specification / Détails techniques | |
|--|---|
| Fuente alimentación / Power supply / Source d'alimentation | 2x1,5V AA DC |
| Autonomía / Operating time / Autonomie | 4h cont. |
| Longitud de onda / Laser wavelength / Longueur d'onde | 650nm |
| Potencia del láser / Output power / Puissance du Laser | < 1mW |
| Tipo de láser / Laser class / Type de Laser | 2 |
| Precisión / Precision / Précision | 0,5 mm/m |
| Rango autonivelación / Self-leveling range / Précision de l'autonivelage | ± 3° |
| Sistema aviso / Warning system / Système d'alerte | luz parpadeante / flashing light / lumière intermittante |
| Tª trabajo / Operating temperature / Température de travail | 0°C - 40°C |

EQUIPADO CON / EQUIPED WITH / EQUIPE:

Maleta plástico / Blow mould case / Malette plastique

Trípode aluminio 45-120 cm / 45-120 cm aluminium tripod / Tripode en aluminium 45-120 cm

Base / Trestle / Base

Gafas / Goggles / Lunettes



NIVEL LASER ROTATORIO STANDARD / STANDARD ROTATORY LASER LEVEL / NIVEAU LASER ROTATIF STANDARD
 STANDARD ROTIERENDE LINIENLASER / LIVELLA GIREVOLE STANDARD / STANDARD ROTERENDE LASERRICHTER
 NÍVEL LASER ROTATIVO STANDARD

| |
|---|
| PROYECCIÓN PUNTUAL (SU GIRO GENERA PLANOS HORIZONTALES Y VERTICALES) LASER POINT (WHEN REVOLVING GENERATES HORIZONTAL AND VERTICAL PLANES) PROJECTIONS INTERMITENTES (SA ROTATION PRODUITS DES TIRETS HORIZONTALAUX ET VERTICAUX) |
| PROYECCIÓN LÁSER HORIZONTAL / HORIZONTAL LASER LINE / LASER HORIZONTAL |
| PROYECCIÓN LÁSER VERTICAL / VERTICAL LASER LINE / LASER VERTICAL |
| PROYECCIÓN CRUCETA / LASER CROSS / LASER EN CROIX |

COD

65515



CE *G12

| Especificaciones técnicas / Technical specification / Détails techniques | |
|--|------------------|
| Fuente alimentación / Power supply / Source d'alimentation | 4x1,5V AA DC |
| Autonomía / Operating time / Autonomie | 8h cont. |
| Longitud de onda / Laser wavelength / Longueur d'onde | 650nm |
| Potencia del láser / Output power / Puissance du Laser | < 1mW |
| Tipo de láser / Laser class / Type de Laser | 2 |
| Precisión / Precision / Précision | 0,5 mm/m |
| Distancia de trabajo / Working distance / Distance de travail | 10m |
| Velocidad rotación / Rotation speed / Vitesse de rotation | 100 - 300 r.p.m. |
| Tª trabajo / Operating temperature / Température de travail | 0°C - 40°C |

EQUIPADO CON / EQUIPED WITH / EQUIPE:

Maleta plástico / Blow mould case / Malette plastique

Trípode aluminio 45-120 cm / 45-120 cm aluminium tripod / Tripode en aluminium 45-120 cm

Base / Trestle / Base

Gafas / Goggles / Lunettes



NIVEL LASER TUBULAR 400MM / SPIRIT LASER LEVEL 400MM / NIVEAU LASER TUBULAIRE 400MM / LASER WASSERWAGEN 400MM / WATERPAS LASER 400MM / LIVELLA LASER 400MM / NÍVEL LASER 400MM

| Especificaciones técnicas / Technical specification / Détails techniques | |
|--|---------------|
| Fuente alimentación / Power supply / Source d'alimentation | 2x1,5V AAA DC |
| Longitud de onda / Laser wavelength / Longueur d'onde | 650nm |
| Potencia del láser / Output power / Puissance du Laser | < 1mW |
| Precisión / Precision / Précision | 0,35 mm/m |
| Precisión burbujas / Vial accuracy / Precision des fioles | 0,5 mm/m |
| Nº burbujas / Vials / Fioles | 2 |
| Distancia de trabajo / Working distance / Distance de travail | 30m |
| Peso / Weight / Poids | 3,2 Kg |



EQUIPADO CON / EQUIPED WITH / EQUIPE:

Maleta de plástico / Blow mould case / Malette en plastique

Trípode 120 cm / 120 cm tripod / Tripode 120 cm

Base rotatoria / Rotary base / Base rotatif

Gafas de mejora de visión láser / Laser vision improving goggles / Lunettes d'amélioration de la vision laser



ACCESORIOS / SPARE PARTS / RECHANGES / ERSATZTEILE / ACCESSORI TOEBEHOREN / ACESSORIOS

TRIPODE CON ELEVADOR PARA NIVEL LASER AUTONIVELANTE PROFESIONAL / ELEVATOR TRIPOD FOR PROFESSIONAL SELF-LEVELING LASER LEVEL / TRIPODE À CRÉMAILLÈRE POUR NIVEAU LASER AUTO-RÉGLABLE PROFESSIONNEL / UNTERGESTELL-EINSTELLBAR / TREPIEDE AD ASCENSORE PER LIVELLA LASER AUTOLIVELLANTE / BOUWSTATIEF / TRIPÉ COM ELEVADOR PARA NIVEL LASER AUTO NIVELANTE PROFISSIONAL

Características:

- Mecanismo de tornillo sinfín para el suave ajuste en altura del nivel de forma manual.
- Elevador graduado en mm para el control preciso de la altura.
- Con cadenas entre las patas para prevenir el deslizamiento del trípode.
- Con tacos de goma para su uso en interiores.
- Altura trípode cerrado: 135,5 cm.
- Altura trípode abierto: 232,5 cm (incluidos los 30 cm del elevador).
- Peso: 7,5 Kg.

Features:

- With worm gear and shaft structure to adjust up and down.
- The elevator column has mm graduation to measure the height.
- Chains between legs to prevent legs from sliding.
- Rubber shoes for indoors use.
- Closed length: 135,5 cm.
- Opened length: 232,5 cm (including 30 cm for central column).
- Weight: 7,5 Kg.

Caractéristiques:

- Mécanisme de levage avec vis sans fin pour un réglage manuel doux.
- Réhausseur gradué pour un contrôle précis de hauteur.
- Avec des chaînes au pieds pour empêcher de riper.
- Avec des caoutchoucs aux pieds pour le travail en intérieur.
- Hauteur du trépode plié: 135,5 cm
- Hauteur du trépode déplié: 232,5 cm (inclus les 30 cm de la crémaillère).
- Poids: 7,5Kg.

COD
65516



TRIPODE CON ELEVADOR PARA NIVEL LASER ROTATORIO PROFESIONAL / ELEVATOR TRIPOD FOR PROFESSIONAL ROTATORY LASER LEVEL / TRIPODE AVEC CRÉMAILLÈRE POUR LASER ROTATIF PROFESSIONNEL / UNTERGESTELL-EINSTELLBAR / TREPIEDE AD ASCENSORE PER LIVELLA LASER GIREVOLE / BOUWSTATIEF / TRIPÉ COM ELEVADOR PARA NIVEL LASER ROTATIVO PROFISSIONAL

Características:

- Ajuste manual del elevador.
- Con cadenas entre las patas para prevenir el deslizamiento del trípode.
- Altura trípode cerrado: 103 cm.
- Altura trípode abierto: 210 cm (incluidos los 50 cm del elevador).
- Peso: 4 Kg.

Features:

- Elevator column adjustable by manual operation.
- Chains between legs to prevent from sliding.
- Closed length: 103 cm.
- Open length: 210 cm (including 50 cm for central column).
- Weight: 4 Kg.

Caractéristiques:

- Ajustement manuel de levée.
- Avec des chaînes aux pieds pour empêcher de riper.
- Hauteur plié: 103 cm
- Hauteur déplié: 210 cm (inclus les 50 cm de la crémaillère).
- Poids: 4 Kg.

COD
65517



SOPORTE PARED / WALL BRACKET / CONSOLE DE MUR / WANDBEFESTIGER / SUPPORTO A PARETE / MUURKLEM / SUPORTE DE PAREDE



COD
65518

Características / Features / Caractéristiques:

- Adecuado para su uso con los niveles láser profesionales (autonivelantes y rotatorio).
- Suitable for its use with our professional laser levels (self-leveling and rotatory).
- Adéquat pour une utilisation avec les niveaux lasers professionnels (auto-réglables ou rotatifs)
- Completamente ajustable en altura y posición.
- Fully adjustable for height and position.
- Totalemt ajustable en hauteur ou en position.



BUSCAPOLOS / VOLTAGE TESTER / TESTEUR / SPANNUNGSPRÜFER / SPANNINGSTESTER CERCAFASE / BUSCA-POLOS

BUSCAPOLOS / VOLTAGE TESTER / TESTEUR / SPANNUNGSPRÜFER / SPANNINGSTESTER / CERCAFASE / BUSCA-POLOS

| COD | | | V | | | |
|-------|------|-----|---------|----|---|---|
| 66072 | 3x15 | 150 | 100-250 | 20 | 6 | 1 |
| 66073 | | 190 | | 30 | | |



BUSCAPOLOS DIGITAL / DIGITAL VOLTAGE TESTER / TESTEUR DIGITAL / DIGITAL SPANNUNGSPRÜFER / DIGITALE SPANNINGSTESTER / CERCAFASE DIGITALE / BUSCA-POLOS DIGITAL

| COD | | | V | | | |
|-------|------|-----|-------|----|---|---|
| 66074 | 3x15 | 160 | 0-220 | 40 | 6 | 1 |

5 NIVELES DE TENSION / 5 VOLTAGE LEVELS



TESTER ELECTRONICO MEDIDOR DE TENSION 2 EN 1 / ELECTRONIC TESTER 2 IN 1 / TESTEUR ELECTRONIQUE A MESURE DE TENSION 2 EN 1 SPANNUNGSPRÜFER ELEKTRONIK, 2 IN 1 / ELECTRONISCHE TESTER 2 IN 1 / TESTER ELECTRONICO 2 IN 1 MEDIDOR DE TENSÃO 2 EM 1

| COD | | V | | | |
|-------|-----|-------|-----|----|---|
| 66075 | 190 | 3-400 | 220 | 40 | 6 |



TESTER ELECTRONICO MEDIDOR DE TENSION 8 EN 1 / ELECTRONIC TESTER 8 IN 1 / TESTEUR ELECTRONIQUE A MESURE DE TENSION 8 EN 1 SPANNUNGSPRÜFER ELEKTRONIK, 8 IN 1 / ELECTRONISCHE TESTER 8 IN 1 / TESTER ELECTRONICO 8 IN 1 MEDIDOR DE TENSÃO 8 EM 1

| COD | | V | | | |
|-------|-----|-------|-----|----|---|
| 66076 | 190 | 3-400 | 220 | 40 | 6 |

7 NIVELES DE TENSION / 7 VOLTAGE LEVELS





BUSCAPOLOS / VOLTAGE TESTER / TESTEUR DE COURANT / SPANNUNGSPRÜFER / SPANNINGSTESTER / CERCAFASE / BUSCA-POLOS classic

| COD | | | | | |
|-------|-------|-----|----|----|---|
| 66070 | 3x65 | 140 | 20 | 12 | 1 |
| 66071 | 4x100 | 190 | 35 | | |



ARTICULOS ELECTRONICOS / ELECTRONIC ITEMS / APPAREILS ÉLECTRONIQUES
ELEKTRONISCHE AUSRÜSTUNGEN / ARTICOLI PER ELETTRONICA
ELECTRONISCHE PRODUCTEN / ARTIGOS ELECTRONICOS

TERMÓMETRO DIGITAL POR INFRARROJOS CON SISTEMA LASER / INFRARED DIGITAL THERMOMETER
THERMOMÈTRE DIGITAL PAR INFRAROUGE / INFRAROT DIGITAL THERMOMETER / TERMOMETRO DIGITALE A RAGGI INFRAROSSI
INFRAROOD DIGITALE THERMOMETER / TERMÓMETRO DIGITAL POR INFRASVERMELHOS

| COD | CAP | ± |  |  |
|-------|---------------|-------|---|---|
| 65500 | -18°C - 450°C | ± 2°C | 525 | 1 |
| | 0°F - 842°F | ± 3°F | | |



Especificaciones técnicas / Technical specification / Détails techniques

| | |
|---|-----|
| Función auto apagado / Auto Power off / Fonction auto-arrêt | ● |
| Indicador de batería baja / Low battery Indication Indicateur de charge de batterie | ● |
| Luz retroalimentada / Back lighth system / Lumière retro alimentée | ● |
| Función on/off de puntero láser / Laser pointer on/off function Fonction on/off du point laser | ● |
| Escala °C/°F seleccionable / °C/°F Selectable Echelle °C/°F sélectionnable | ● |
| Función fijación de datos / Data hold function Fonction mémorisation des renseignements | ● |
| Distancia puntual: / Distance spot: / Distance ponctuelle | 8:1 |



CE *G12

TERMÓMETRO DIGITAL / DIGITAL THERMOMETER / THERMOMÈTRE DIGITAL / DIGITAL THERMOMETER / TERMOMETRO DIGITALE
DIGITALE THERMOMETER / TERMÓMETRO DIGITAL

| COD | CAP | ± |  |  |
|-------|----------------|------------------------|---|---|
| 65504 | -50°C - 1300°C | ± 0,3% (-50 - 1000°C) | 390 | 1 |
| | | ± 0,5% (1000 - 1300°C) | | |
| | -58°F - 1999°F | ± 0,3% (-58 - 1999°F) | | |



Especificaciones técnicas / Technical specification / Détails techniques

| | |
|--|---|
| Función fijación de datos / Data hold function Fonction mémorisation des renseignements | ● |
| Función MAX / MAX Function / Fonction max. | ● |
| Indicador de batería baja / Low battery indication Indicateur de charge de batterie | ● |
| Tipo de sensor: / Sensor Type: / Type de senseur | K |



CE *G12

TACÓMETRO DIGITAL / DIGITAL TACHOMETER / TACHYMÈTRE DIGITAL / DIGITAL TACHOMETER / TACCHIMETRO DIGITALE
DIGITALE TACHOMETER / TACÓMETRO DIGITAL

| COD | CAP | ± |  |  |
|-------|------------------------------|-------|---|---|
| 65503 | Láser: 2,5 - 99.999 rpm | 0,05% | 720 | 1 |
| | Motor/engine: 100-20.000 rpm | | | |



Especificaciones técnicas / Technical specification / Détails techniques

| | |
|--|----------------------|
| Detección inducción electromagnética en motores / Engine electromagnetic induction detection / Détection de l'induction électromagnétique dans les moteurs | ● |
| Detección láser de luz reflectante / Reflective light laser detection Détection laser de lumière réfléchissante | ● |
| Distancia medición motores / Engine measurement distance Distance de mesure des moteurs | 30-200mm |
| Distancia medición láser / Laser measurement distance Distance de mesure laser | hasta 2m up to 2m |
| Resolución / Resolution / Résolution | 0,1/1 |
| Memoria de valor min/max / Min/Max last value memory Mémoire de valeur : min / Max | ● |



CE *G12

PINZA AMPERIMETRICA / CLAMP METER / PINCE AMPÈRE - MÉTRIQUE / STROMZANGE / PINZA APERIMETRICA / STROOMTANG
 PINÇA AMPERIMÉTRICA



| | | |
|------------|---|---|
| COD |  |  |
| 65507 | 470 | 1 |

Especificaciones técnicas / Technical specification / Détails techniques

| | |
|---|----------------------|
| Función fijación de datos / Data hold function Fonction mémorisation des renseignements | ● |
| Función Pico / Peack Function / Fonction de piquage | ● |
| Protección Cat III / Cat III protection / Protezione CAT III | 600V |
| Indicador de batería baja / Low battery indication Indicateur de charge de batterie | ● |
| Medidor de continuidad por sonido / Continuity buzzer Mesure de continuité par son | ● |
| Función auto apagado / Auto Power off / Fonction auto-arrêt | ● |
| ACA | 200A / 600A (± 1,5%) |
| ACV | 600V (± 1,5%) |
| DCV | 600V (± 1,5%) |
| Ω | 200Ω (± 1%) |
| Hz | 10 MHz (± 0,8%) |



PINZA AMPERIMETRICA ACA-DCA / ACA-DCA CLAMP METER / PINCE AMPÈRE - MÉTRIQUE ACA-DCA / STROMZANGE / PINZA APERI-
 METRICA / STROOMTANG PINÇA AMPERIMÉTRICA



| | | |
|------------|---|---|
| COD |  |  |
| 65520 | 500 | 1 |

Especificaciones técnicas / Technical specification / Détails techniques

| | |
|---|---------------------|
| Función fijación de datos / Data hold function Fonction mémorisation des renseignements | ● |
| Protección Cat II / Cat II protection / Protezione CAT II | 1000V |
| Medición intensidad CC-CA / ACA-DCA Measurement Mesure d'intensité CC CA | ● |
| Indicador de batería baja / Low battery indication Indicateur de charge de batterie | ● |
| Medidor de continuidad por sonido / Continuity buzzer Mesure de continuité par son | ● |
| ACA | 200A / 1000A (± 2%) |
| DCA | 200A / 1000A (± 2%) |
| ACV | 750V (± 1,2%) |
| DCV | 1000V (± 1%) |
| Ω | 200KΩ (± 1%) |
| Hz | 2 KHz (± 2,5%) |





MULTIMETRO DIGITAL / DIGITAL MULTIMETER / MULTIMÉTRE DIGITAL / DIGITALE MUTLIMETER / MULTIMETRO DIGITALE / DIGITALE MULTIMETER / MULTIMETRO DIGITAL

| COD |  |  |
|--|---|---|
| 65505 | 500 | 1 |
| Especificaciones técnicas / Technical specification / Détails techniques | | |
| Función Auto-Range / Auto-Range Function Fonction auto-range | | ● |
| Función fijación de datos / Data hold function Fonction mémorisation des renseignements | | ● |
| Escala gráfica activa / Active graphic scale Echelle graphique active | | ● |
| Protección Cat II / Cat II protection / Proteccion CAT II | 1000V | |
| Medidor de continuidad por sonido / Continuity buzzer Mesure de continuité par son | | ● |
| DCV | 326 mV - 1000V (± 0,5%) | |
| ACV | 3,26 V - 750 V (± 0,8%) | |
| DCA | 32,6µA - 10A (± 1,2%) | |
| ACA | 32,6µA - 10A (± 1,8%) | |
| Ω | 326Ω - 32,6MΩ (± 0,8%) | |
| F | 326nF - 32,6µF (± 5%) | |
| Hz | 32,6 KHz - 200 KHz (± 1,5%) | |



MULTÍMETRO DIGITAL PARA AUTOMÓVILES / AUTOMOTIVE DIGITAL MULTIMETER / MULTIMÉTRE DIGITAL POUR AUTO
AUTOMOTIVE DIGITALER MUTLIMETER / MULTIMETRO DIGITALE PER AUTOMOBILI / AUTOMOTIVE DIGITALE MULTIMETER
MULTIMETRO DIGITAL AUTO

| COD |  |  |
|--|---|---|
| 65506 | 835 | 1 |
| Especificaciones técnicas / Technical specification / Détails techniques | | |
| Función fijación de datos / Data hold function / Fonction mémorisation des renseignements | | ● |
| Protección Cat II / Cat II protection / Proteccion CAT II | 1000V | |
| Medidor de continuidad por sonido / Continuity buzzer Mesure de continuité par son | | ● |
| Luz retroalimentada / Back light system Lumière retro alimentée | | ● |
| DCV | 2V - 1000V (± 0,5%) | |
| ACV | 2V - 750V (± 0,8%) | |
| DCA | 20mA - 20A (± 1,2%) | |
| ACA | 20mA - 20A (± 1,8%) | |
| Ω | 20°Ω - 20MΩ (± 0,8%) | |
| DWELL | 3CYL - 8CYL (± 1,5%) | |
| TACHX10 | 3CYL - 8CYL (± 1,5%) | |
| °C | -40°C - 1000°C (± 0,75%) | |



MEDIDOR DE RESISTENCIA DE AISLAMIENTO / MEGGER / MESUREUR DE RÉSISTANCE D'ISOLATION / WIDERSTAND MAB
MISURATORE DI RESISTENZA / WEERSTANDSMETER / MEDIDOR DE RESISTÊNCIA DE ISOLAMENTO

| COD | 1050 | 1 |
|--|---|---|
| Especificaciones técnicas / Technical specification / Détails techniques | | |
| Función Auto-Apagado / Auto Power off Fonction auto-range | | ● |
| Indicador de batería baja / Low battery indication Indicateur de charge de batterie | | ● |
| El timbre sonará si la resistencia es superior a: The timbre will ring if the resistance is higher than: La sonnerie se déchenchera si la résistance est supérieure à: | 50Ω | |
| Fuente alimentación / Power supply Source d'alimentation | 6x1,5 V AA DC | |
| ACV | 1 V - 600 V (±1,5%+5) | |
| Ω | 0,25MΩ - 200MΩ (± 3%+3) 200MΩ - 2000MΩ (±5%+5) | |



CAMARA DE INSPECCION / INSPECTION CAMERA / CAMÉRA D'INSPECTION
INSPEKTIONSKAMERA / CAMERA PER ISPEZIONI / INSPECTIECAMERA / CÂMARA DE INSPECÇÃO



| COD | L(mm) | Ø (mm) | 1050 |
|--|-------|--------|-----------------|
| 65790 | 1 | 7 | 280 |
| Especificaciones técnicas / Technical specification / Détails techniques | | | |
| Longitud de inspección / Inspection length / Longueur d'inspection | | | 1m |
| Ø fibra óptica / Fibre optics Ø / Ø fibre optique | | | 7mm |
| Pixels en imagen / Image pixels / Pixels en image | | | 7200 |
| Campo de visión / Field of view / Champ de vision | | | 45° |
| Espejo visión 90° / 90° view mirror / Miroir á 90° | | | ● |
| Estuche aluminio / Aluminium case / Etui en aluminium | | | ● |
| Pilas / Batteries / Piles | | | 3xAA LR6 (1,5V) |
| Iluminación / Lighting / illumination | | | 2 LED |
| Fuerte intensidad luminosa / Strong light intensity / Forte intensité lumineuse | | | ● |
| Vida del LED / LED long life / Duré de vie du LED | | | 100.000h |
| Resistente al agua, aceite, gasoil, ácidos débiles y álcali / Resistant to water, oil, diesel, weak acid and alkali / Résistents á l'eau, á l'huile, aux acides légers et aux alcaloïdes | | | ● |
| Temperatura de trabajo / Work temperature / Température de travail | | | -10°C - 80°C |
| Dimensiones estuche / Case dimensions / Dimensions de l'étui | | | 310x240x70mm |
| Resistencia a campos electromagnéticos / Electromagnetic fields resistant / Résistant aux champs électromagnétiques | | | ● |

CALIBRES / CALIPERS / PIEDS À COULISSE / WERKSTATTMESSSCHIEBERS / CALIBRI WERKPLAATSCHUIFMETERS / PAQUÍMETROS

CALIBRE PIE DE REY / VERNIER CALIPER / PIED À COULISSE / TASCHENMESSSCHIEBER / CALIBRI A CORSOIO / SCHUIFMAAT PAQUIMETRO

| COD | L (mm) | | A | L | gr. | |
|-------|--------|------|----|-----|-----|---|
| 65479 | 150 | 0,02 | 40 | 236 | 360 | 6 |
| 65480 | 200 | | 50 | 286 | 450 | |

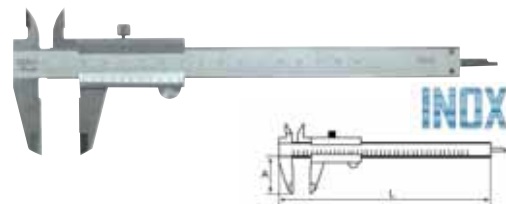

CALIBRE PIE DE REY (BLOCAJE POR RESORTE) / VERNIER CALIPER WITH THUMB BRAKE / PIEDS À COULISSE WERKSTATTMESSSCHIEBER / CALIBRI A CORSOIO (BLOCCAGGIO A MOLLA) / WERKPLAATSSCHUIFMAAT PAQUIMETRO DE BLOCAGEM POR MOLA

| COD | L (mm) | | A | L | gr. | |
|-------|--------|------|----|-----|-----|---|
| 65481 | 150 | 0,02 | 40 | 236 | 360 | 6 |
| 65482 | 200 | | 50 | 286 | 450 | |



CALIBRE PIE DE REY CON BOCAS LARGAS / LONG TIP VERNIER CALIPER / PIED À COULISSE GRANDES OUVERTURES TIEFENMESSSCHIEBER / CALIBRI A CORSOIO A BOCCA LARGA / DIEPTEMETER / PAQUIMETRO COM PONTAS COMPRIDAS

| COD | L (mm) | | A | L | gr. | |
|-------|--------|------|----|-----|-----|---|
| 65483 | 200 | 0,02 | 65 | 348 | 700 | 6 |

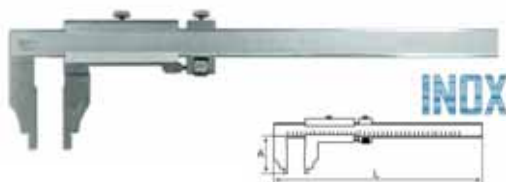

CALIBRE DIGITAL / DIGITAL CALIPER / PIED À COULISSE DIGITAL / DIGITAL-TASCHENMESSSCHIEBER / CALIBRO DIGITALE DIGITALE SCHUIFMAAT / PAQUIMETRO DIGITAL

| COD | L (mm) | | A | L | gr. | |
|-------|--------|--|----|-----|-----|---|
| 65484 | 150 | | 40 | 236 | 430 | 1 |
| 65485 | 200 | | 50 | 286 | 600 | |

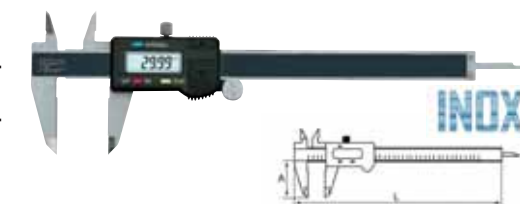

CALIBRE DIGITAL (CARCASA METÁLICA) / METAL CASE DIGITAL CALIPER / PIED À COULISSE DIGITAL MÉTALLIQUE TASCHENMESSSCHIEBER ROSTFREI / CALIBRO DIGITALE CON CASSA METALLICA / SCHUIFMAAT ROESTVRIJ STAAL PAQUIMETRO DIGITAL COM CARÇAÇA DE METAL

| COD | L (mm) | | A | L | gr. | |
|-------|--------|--|----|-----|-----|---|
| 65486 | 150 | | 40 | 236 | 550 | 1 |
| 65487 | 200 | | 50 | 286 | 725 | |

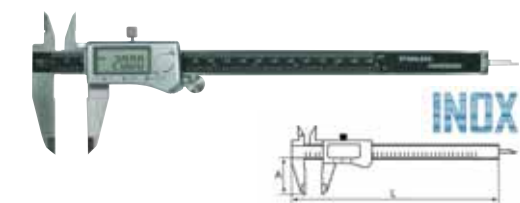

CALIBRE DIGITAL (CARCASA METÁLICA) / METAL CASE DIGITAL CALIPER / PIED À COULISSE DIGITAL MÉTALLIQUE TASCHENMESSSCHIEBER ROSTFREI / CALIBRO DIGITALE CON CASSA METALLICA / SCHUIFMAAT ROESTVRIJ STAAL PAQUIMETRO DIGITAL COM CARÇAÇA DE METAL

| COD | IP | L (mm) | | A | L | gr. | |
|-------|----|--------|----|-----|-----|-----|--|
| 65488 | 67 | 150 | 40 | 236 | 725 | 1 | |

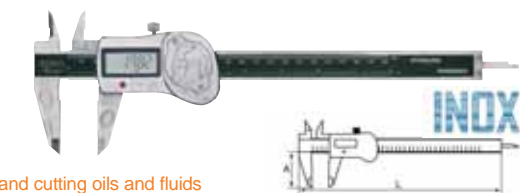

Se puede usar con refrigerante, taladrina, agua y aceites de corte / Able to be used with coolant, water and cutting oils and fluids
On peut l'utiliser en présence de réfrigérants, huile soluble, d'eau et d'huile de coupe

CALIBRE DIGITAL LIGERO / FIBERGLASS DIGITAL CALIPER / PIED À COULISSE DIGITAL LÉGER / DIGITAL TASCHENMESSSCHIEBER
 FIBREGLASS / CALIBRO DIGITALE IN FIBRA DI VETRO / FIBERGLASS DIGITALE SCHUIFMAAT / PAQUIMETRO DIGITAL DE FIBRA DE VIDRO

| COD | E (mm) | A | L | gr. | |
|-------|--------|----|-----|-----|---|
| 65489 | 150 | 40 | 236 | 225 | 1 |

Fibra de carbono reforzada / Reinforced fiber carbon / Fibre de carbone renforcée

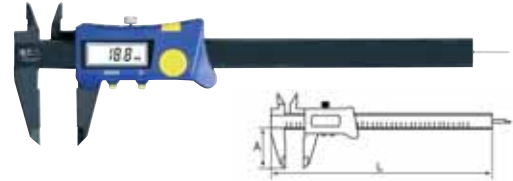

CALIBRE DE PROFUNDIDAD DIGITAL / DIGITAL DEPTH GAGE / SONDEUR DIGITAL / DIGITALE TIEFVERMESSUNG / CALIBRO DI PROFONDITA' DIGITALE / DIGITALE MEETDIEPTEMETER / BATIMETRO DE PROFUNDIDADE DIGITAL

| COD | E (mm) | A | L | gr. | |
|-------|--------|-----|-----|-----|---|
| 65490 | 150 | 100 | 230 | 500 | 1 |
| 65491 | 200 | | 280 | 700 | |

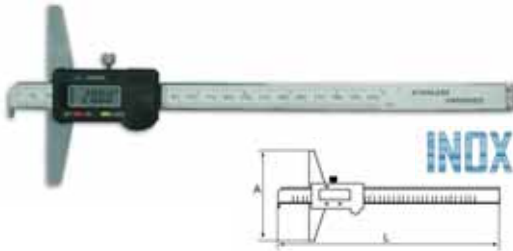

MICRÓMETRO PARA EXTERIORES / OUTER MICROMETER / MICROMÈTRE EXTÉRIEUR / PRÄZISIONS-BÜGELMESSSCHRAUBEN / MICROMETRI PER ESTERNI / BUITENSCHROEFMAAT / MICRÓMETRO PARA EXTERIORES

| COD | E (mm) | (mm) | gr. | |
|-------|--------|------|-----|---|
| 65492 | 0-25 | 0,01 | 425 | 1 |
| 65493 | 25-50 | | 525 | |
| 65494 | 50-75 | | 700 | |
| 65495 | 75-100 | | 880 | |



MICRÓMETRO DIGITAL PARA EXTERIORES / OUTER DIGITAL MICROMETER / MICROMÈTRE DIGITAL EXTÉRIEUR / PRÄZISIONS-BÜGELMESSSCHRAUBEN DIGITAL / MICROMETRI DIGITALE PER ESTERNI / DIGITALE BUITENSCHROEFMAAT / MICRÓMETRO PARA EXTERIORES DIGITAL

| COD | E (mm) | gr. | |
|-------|--------|-----|---|
| 65496 | 0-25 | 500 | 1 |
| 65497 | 25-50 | 600 | |
| 65498 | 50-75 | 750 | |
| 65499 | 75-100 | 950 | |



RELOJ COMPARADOR / DIAL INDICATOR / MONTRE COMPARATIVE / KLEINMESSUHR / OROLOGIO DI COMPARAZIONE / MEETKLOK / RELOGIO COMPARADOR

| COD | E (mm) | gr. | |
|-------|--------|-----|---|
| 65501 | 0-10 | 345 | 1 |



RELOJ COMPARADOR DIGITAL / DIGITAL INDICATOR / MONTRE COMPARATIVE DIGITALE / DIGITALE INDIKATOR / OROLOGIO DI COMPARAZIONE DIGITALE / DIGITALE INDICATOR / RELOGIO COMPARADOR DIGITAL

| COD | E (mm) | gr. | |
|-------|--------|-----|---|
| 65502 | 0-12,5 | 450 | 1 |



ESCUADRAS DE TRABAJO / WORKSHOP SQUARES / EQUERRES DE TRAVAIL / WERKSTATTWINKEL / SQUADRE SEMPLICI / BANKWERKER WINKELHAAK / ESQUADROS DE TRABALHO

ACERO AL CARBONO / CARBON STEEL / ACIER EN CARBONNE

| COD | H x L mm | W x Z mm | gf | |
|-------|-------------|-------------|------|---|
| 65674 | 70x50 | 15x5 | 75 | 1 |
| 65675 | 100x70 | 20x5 | 125 | |
| 65676 | 150x100 | 25x5 | 220 | |
| 65677 | 200x130 | 30x6 | 390 | |
| 65678 | 250x165 | 35x7 | 655 | |
| 65679 | 300x200 | 40x8 | 806 | |
| 65680 | 400x265 | 45x10 | 1852 | |
| 65681 | 500x330 | 50x10 | 2300 | |

DIN 875/1



ACERO INOXIDABLE / STAINLESS STEEL / ACIER INOXIDABLE

| COD | H x L mm | W x Z mm | gf | |
|-------|-------------|-------------|-----|---|
| 65682 | 70x50 | 15x5 | 75 | 1 |
| 65683 | 100x70 | 20x5 | 125 | |
| 65684 | 150x100 | 25x5 | 220 | |
| 65685 | 200x130 | 30x6 | 390 | |
| 65686 | 250x165 | 35x7 | 655 | |
| 65687 | 300x200 | 40x8 | 806 | |

DIN 875/1



ACERO INOXIDABLE TEMPLADO / HARDENED STAINLESS STEEL / ACIER INOXIDABLE TREMPÉ

| COD | H x L mm | W x Z mm | gf | |
|-------|-------------|-------------|------|---|
| 65713 | 50x40 | 12x5 | 35 | 1 |
| 65714 | 75x50 | 15x5 | 60 | |
| 65715 | 100x70 | 20x5 | 117 | |
| 65716 | 150x100 | 25x5 | 225 | |
| 65717 | 200x130 | 30x6 | 457 | |
| 65718 | 250x165 | 35x7 | 725 | |
| 65719 | 300x200 | 40x8 | 1055 | |

DIN 875/0

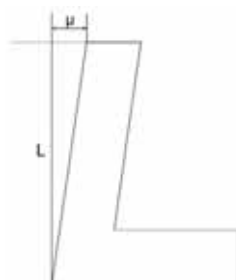

L = mm

Class

| DIN 875 | | | | | | | | |
|---------|----|----|-----|-----|-----|-----|-----|-----|
| | 50 | 75 | 100 | 150 | 200 | 250 | 300 | 500 |
| 00 | 3 | 3 | 3 | 4 | 4 | 5 | 5 | 7 |
| 0 | - | 7 | 7 | 8 | 9 | 10 | 11 | 15 |
| 1 | - | 14 | 15 | 18 | 20 | 23 | 25 | 35 |
| 2 | - | 28 | 30 | 35 | 40 | 45 | 50 | 70 |

ESCUADRAS SOMBRERO / WORKSHOP SQUARE WITH BASE / EQUERRE DE TRAVAIL A BASE / WERKSTATTWINKEL / SQUADRE A CAPPELLO / BLOKWINKELHAAK / ESQUADROS DE TRABALHO COM CEPO

ACERO AL CARBONO / CARBON STEEL / ACIER EN CARBONNE

| COD | H x L mm | W x Z mm | BF | |
|-------|-------------|-------------|------|---|
| 65690 | 70x50 | 15x5 | 80 | 1 |
| 65691 | 100x70 | 20x5 | 130 | |
| 65692 | 150x100 | 25x5 | 227 | |
| 65693 | 200x130 | 30x6 | 398 | |
| 65694 | 250x165 | 35x7 | 662 | |
| 65695 | 300x200 | 40x8 | 810 | |
| 65696 | 400x265 | 45x10 | 1858 | |
| 65697 | 500x330 | 50x10 | 2305 | |

DIN 875/1



ACERO INOXIDABLE / STAINLESS STEEL / ACIER INOXIDABLE

| COD | H x L mm | W x Z mm | BF | |
|-------|-------------|-------------|-----|---|
| 65698 | 70x50 | 15x5 | 80 | 1 |
| 65699 | 100x70 | 20x5 | 130 | |
| 65700 | 150x100 | 25x5 | 227 | |
| 65701 | 200x130 | 30x6 | 398 | |
| 65702 | 250x165 | 35x7 | 662 | |
| 65703 | 300x200 | 40x8 | 810 | |

DIN 875/1

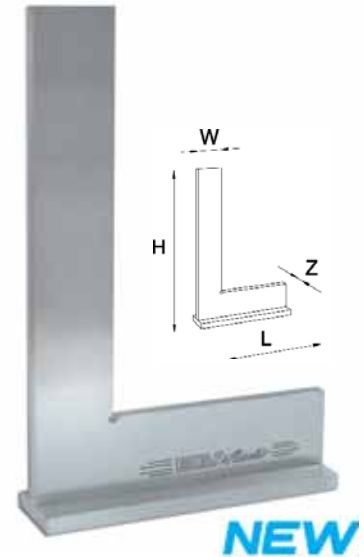

ACERO INOXIDABLE TEMPLADO / HARDENED STAINLESS STEEL / ACIER INOXIDABLE TREMPÉ

| COD | H x L mm | W x Z mm | BF | |
|-------|-------------|-------------|------|---|
| 65727 | 50x40 | 12x5 | 35 | 1 |
| 65728 | 75x50 | 15x5 | 60 | |
| 65729 | 100x70 | 20x5 | 117 | |
| 65730 | 150x100 | 25x5 | 225 | |
| 65731 | 200x130 | 30x6 | 457 | |
| 65732 | 250x165 | 35x7 | 725 | |
| 65733 | 300x200 | 40x8 | 1055 | |

DIN 875/0

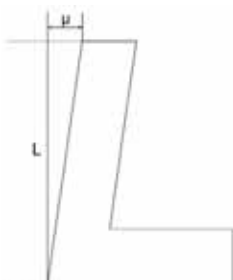

| | | DIN 875 | | | | | | | |
|--------|----|---------|----|-----|-----|-----|-----|-----|-----|
| L = mm | | 50 | 75 | 100 | 150 | 200 | 250 | 300 | 500 |
| | 00 | 3 | 3 | 3 | 4 | 4 | 5 | 5 | 7 |
| | 0 | - | 7 | 7 | 8 | 9 | 10 | 11 | 15 |
| Class | 1 | - | 14 | 15 | 18 | 20 | 23 | 25 | 35 |
| | 2 | - | 28 | 30 | 35 | 40 | 45 | 50 | 70 |

ESCUADRAS DE TRABAJO BISELADAS / BEVELED WORKSHOP SQUARE / EQUERRE DE TRAVAIL BISEAUTÉES / SCHNITTMACHERWINKEL / SQUADRA DA LAVORO SMUSSATA / PLAT-EN BLOK HAARWINKELHAAK / ESQUADROS DE TRABALHO BISELADOS

ACERO INOXIDABLE TEMPLADO / HARDENED STAINLESS STEEL / ACIER INOXIDABLE TREMPÉ

| COD | H x L mm | W x Z mm | BF | |
|-------|-------------|-------------|-----|---|
| 65739 | 50x40 | 14x4 | 30 | 1 |
| 65740 | 75x50 | 16x4 | 48 | |
| 65741 | 100x70 | 20x5 | 104 | |
| 65742 | 150x100 | 28x6 | 250 | |
| 65743 | 200x130 | 30x7 | 445 | |

DIN 875/00



NEW

| COD | H x L mm | A x B mm | C x D mm | BF | |
|-------|-------------|-------------|-------------|----|---|
| 65744 | 25x20 | 5x3,5 | 6x3,5 | 26 | 1 |
| 65745 | 40x24 | | 8,3,5 | 36 | |

DIN 875/00



NEW

ESCUADRA DE PRECISION / PRECISION SQUARE / EQUERRE DE PRÉCISION / PRÄZISIONSWINKEL / SQUADRE DI PRECISIONE / PRECISIE WINKELHAAK / ESQUADRO DE PRECISÃO

ACERO AL CARBONO / CARBON STEEL / ACIER EN CARBONNE

| COD | H x L mm | A x B mm | C x D mm | BF | |
|-------|-------------|-------------|-------------|-----|---|
| 65746 | 50x40 | 14x10 | 16x2 | 70 | 1 |
| 65747 | 75x50 | 14x10 | 16x2 | 80 | |
| 65748 | 100x70 | 18x10 | 20x3 | 130 | |
| 65749 | 150x100 | 24x14 | 25x3 | 225 | |
| 65750 | 200x130 | 28x16 | 30x4 | 395 | |

DIN 875/00



NEW

ACERO INOXIDABLE / STAINLESS STEEL / ACIER INOXIDABLE

| COD | H x L mm | A x B mm | C x D mm | BF | |
|-------|-------------|-------------|-------------|-----|---|
| 65751 | 50x40 | 14x10 | 16x2 | 70 | 1 |
| 65752 | 75x50 | 14x10 | 16x2 | 80 | |
| 65753 | 100x70 | 18x10 | 20x3 | 130 | |
| 65754 | 150x100 | 24x14 | 25x3 | 225 | |
| 65755 | 200x130 | 28x16 | 30x4 | 395 | |

DIN 875/00



NEW

ESCUADRA DE PRECISION BISELADA / BEVELED PRECISION SQUARE / EQUERRE DE PRÉCISION BISEAUTÉE / SCHNITTMACHERWINKEL / SQUADRE DI PRECISIONE SMUSSATA / PLAT-EN BLOK HAARWINKELHAAK / ESQUADRO DE PRECISÃO BISELADO

ACERO INOXIDABLE TEMPLADO / HARDENED STAINLESS STEEL / ACIER INOXIDABLE TREMPÉ

| COD | H x L mm | A x B mm | C x D mm | BF | |
|-------|-------------|-------------|-------------|-----|---|
| 65761 | 50x40 | 14x10 | 16x2 | 32 | 1 |
| 65762 | 75x50 | 14x10 | 16x2 | 50 | |
| 65763 | 100x70 | 18x12 | 20x3 | 106 | |
| 65764 | 150x100 | 24x14 | 25x3 | 253 | |
| 65765 | 200x130 | 28x16 | 30x4 | 450 | |

DIN 875/00



NEW

ESCUADRAS DE ACERO INOXIDABLE / STAINLESS STEEL SQUARES / EQUERRES EN ACIER INOX / ROSTFREI WERKSTATWINKEL / SQUADRA ACCIAIO INOX ROESTVRIJE WINKELHAAK / ESQUADRO DE AÇO INOXIDÁVEL

| COD | Angulo Angle | Tipo/Type | Dimensiones Dimensions | | |
|-------|--------------|----------------------|------------------------|-----|---|
| 65799 | 45° | Lisa / Straight | 150x100 | 200 | 1 |
| 65800 | | Sombrero / With base | | 290 | |
| 65801 | 60° | Lisa / Straight | | 210 | |
| 65802 | | Sombrero / With base | | 310 | |
| 65803 | 120° | Lisa / Straight | 75x75 | 100 | |
| 65804 | | | 100x100 | 185 | |
| 65805 | 135° | Sombrero / With base | 150x150 | 180 | |
| 65806 | | | 150x100 | 310 | |
| 65807 | | | | | |

DIN 875/2



ESCUADRA MULTIGRADOS DE SOMBRERO / FLANGED DOUBLE-MITRE SQUARE / EQUERRE MULTIGRADE À CHAPEAU / GEHRUNGSWINKEL / SQUADRA A CAPPELLO DOPPIO METRO VERSTEKWINKELHAAK / ESQUADRO MULTIGRAUS COM CEPO

| COD | A | | |
|-------|-----|-----|---|
| 65809 | 100 | 280 | 3 |
| 65810 | 125 | 430 | |
| 65811 | 150 | 700 | |
| 65812 | 200 | 910 | |

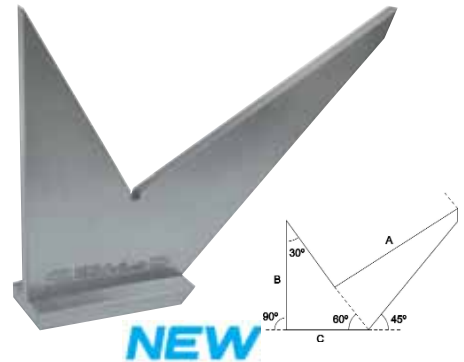

ESCUADRA FALSA / SLIDING BEVELS / FAUSSE ÉQUERRE / VERSTELLBARE WINKELMESSER / SQUADRA FALSA / VERSTELBARE WINKELHAAK / SUTA

| COD | mm Hoja/Blade | Cuerpo/Body | | |
|-------|---------------|------------------|-----|---|
| 65768 | 250 | Plástico/Plastic | 90 | 6 |
| 65769 | 300 | Plástico/Plastic | 100 | |



| COD | mm Hoja/Blade | Cuerpo/Body | | |
|-------|---------------|-------------|-----|---|
| 65770 | 250 | Al | 260 | 6 |
| 65771 | 300 | Al | 270 | |



COMPASES PLANOS / DIVIDERS / COMPAS PLAT / ZIRKEL / COMPASSI PIATTI / STEEKPASSER / COMPASSOS DE BICOS

STANDARD

| COD | L mm | gr. | |
|-------|---------|------|---|
| 65605 | 150 | 55 | 3 |
| 65606 | 200 | 90 | |
| 65607 | 250 | 150 | |
| 65608 | 300 | 160 | |
| 65609 | 400 | 375 | |
| 65610 | 500 | 490 | |
| 65611 | 600 | 1025 | |
| 65612 | 800 | 1650 | |
| 65613 | 1000 | 2230 | |



NEW

COMPAS DE 1/4 / WING DIVIDER / COMPAS DE 1/4 / SPITZZIRKEL M. BOGEN / COMPASSO DA 1/4 / STEEKPASSER MET INSTELBOOG / COMPASSOS DE 1/4

| COD | L mm | gr. | |
|-------|---------|-----|---|
| 65614 | 150 | 160 | 3 |
| 65615 | 200 | 180 | |
| 65616 | 200 | 190 | |
| 65617 | 300 | 210 | |



NEW

COMPAS DE 1/4 PORTALÁPICES / WING DIVIDER PENCIL HOLDER / COMPAS DE 1/4 À CRAYON / SPITZZIRKEL M. BOGEN U. STIFTHALTER / COMPASSO DA 1/4 PORTAMATITE / STEEKPASSER MET INSTELBOOG EN PENHOUDER / COMPASSOS DE 1/4 PORTA-LÁPIS

| COD | L mm | gr. | |
|-------|---------|-----|---|
| 65618 | 150 | 160 | 3 |
| 65619 | 200 | 180 | |
| 65620 | 200 | 190 | |
| 65621 | 300 | 210 | |



NEW

COMPAS DE INTERIORES / INSIDE CALIPER / COMPAS INTÉRIEUR / LOCHZIRKEL / COMPASSI PERE INTERNI / VOETJESPASSER / COMPASSOS DE INTERIORES

| COD | L mm | gr. | |
|-------|---------|-----|---|
| 65622 | 150 | 60 | 3 |
| 65623 | 200 | 115 | |
| 65624 | 200 | 170 | |
| 65625 | 300 | 220 | |
| 65626 | 400 | 450 | |



NEW

COMPAS DE EXTERIORES / OUTSIDE CALIPER / COMPAS EXTÉRIEUR / GREIFZIRKEL / COMPASSI PER ESTERNI / KROMPASSER / COMPASSOS DE EXTERIORES

| COD | L mm | gr. | |
|-------|---------|------|---|
| 65627 | 150 | 85 | 3 |
| 65628 | 200 | 135 | |
| 65629 | 200 | 195 | |
| 65630 | 300 | 255 | |
| 65631 | 400 | 515 | |
| 65632 | 500 | 710 | |
| 65633 | 600 | 1350 | |
| 65634 | 800 | 2140 | |
| 65635 | 1000 | 3030 | |



NEW

COMPASES DE MUELLE / SPRING DIVIDERS / COMPAS POUR RESSORTS / SCHRAUBENZIRKEL / COMPASSI A MOLLA / STEEKPASSER MET VEER / COMPASSOS DE MOLA

STANDARD

| COD | L mm | gr. | |
|-------|---------|-----|---|
| 65636 | 100 | 70 | 3 |
| 65637 | 125 | 80 | |
| 65638 | 150 | 100 | |
| 65639 | 200 | 145 | |
| 65640 | 250 | 175 | |
| 65641 | 300 | 230 | |
| 65642 | 400 | 260 | |
| 65643 | 500 | 310 | |



COMPAS DE PUNTAS INTERCAMBIABLES / WITH REPLACEABLE NEEDLES / COMPAS À POINTES INTERCHANGEABLES
 MIT ERSATZ NADELN / COMPASSI CON PUNTA INTERCAMBIABILE / MET WISSELPENNEN / COMPASSOS DE PONTAS INTERMUTÁVEIS

| COD | L mm | gr. | | Punta/Needle |
|-------|---------|-----|---|--------------|
| 65659 | 100 | 70 | 3 | 65667 |
| 65660 | 125 | 80 | | |
| 65661 | 150 | 100 | | |
| 65662 | 200 | 145 | | |
| 65663 | 250 | 175 | | |
| 65664 | 300 | 210 | | |



COMPAS DE INTERIORES / INSIDE CALIPER / COMPAS INTÉRIEUR / LOCHZIRKEL / COMPASSI PERE INTERNI / VOETJESPASSER
 COMPASSOS DE INTERIORES

| COD | L mm | gr. | |
|-------|---------|-----|---|
| 65644 | 100 | 55 | 3 |
| 65645 | 125 | 85 | |
| 65647 | 200 | 160 | |
| 65648 | 250 | 180 | |
| 65649 | 300 | 220 | |



COMPAS DE EXTERIORES / OUTSIDE CALIPER / COMPAS EXTÉRIEUR / GREIFZIRKEL / COMPASSI PER ESTERNI / KROMPASSER
 COMPASSOS DE EXTERIORES

| COD | L mm | gr. | |
|-------|---------|-----|---|
| 65651 | 100 | 60 | 3 |
| 65653 | 150 | 80 | |
| 65654 | 200 | 150 | |
| 65655 | 250 | 200 | |
| 65656 | 300 | 225 | |
| 65658 | 500 | 370 | |



ESCUADRA DE ALUMINIO / ALUMINIUM SQUARE / EQUERRE EN ALUMINIUM / ALUMIUM WINKELHAKEN / SQUADRA IN ALLUMINIO / ALUMINIUM WINKELHAAK / ESQUADRO DE ALUMÍNIO

| COD | H x L (mm) | OP | |
|-------|------------|-----|---|
| 65813 | 200x135 | 150 | 1 |
| 65814 | 250x150 | 185 | |
| 65815 | 300x165 | 200 | |
| 65816 | 400x200 | 300 | |

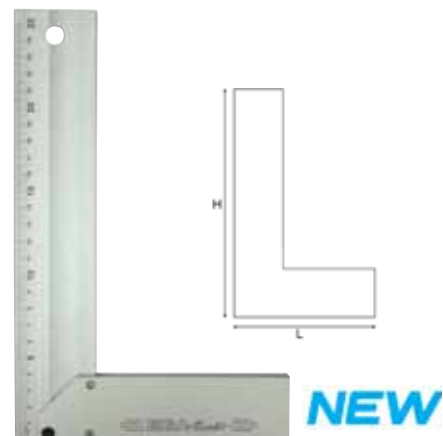

GONIÓMETRO / PROTRACTOR / GONIOMÈTRE / WINKELPRÜFLEHRE / GONIOMETRO / HOEK STAAL / GONIÓMETRO

GONIÓMETRO DE ACERO INOXIDABLE / STAINLESS STEEL PROTRACTOR / GONIOMÈTRE EN ACIER INOX / WINKELPRÜFLEHRE ROESTFREI STAHL / GONIOMETRO IN ACCIAIO INOX / HOEKMETER ROESTVRIJ STAAL / GONIÓMETRO DE AÇO INOXIDÁVEL

| COD | A (mm) | L (mm) | Precisión Accuracy | OP | Funda cuero/Leather bag |
|-------|--------|--------|--------------------|-----|-------------------------|
| 65818 | 80 | 120 | 1° | 120 | 1 |
| 65819 | 120 | 150 | | 210 | |
| 65820 | 150 | 200 | | 300 | |
| 65821 | 200 | 300 | | 410 | |
| 68822 | 300 | 500 | | 500 | |



GONIÓMETRO CON HOJA DESLIZANTE / PROTRACTOR WITH MOVEABLE BLADE / GONIOMÈTRE AVEC LAME AMOVIBLE WINKELPRÜFLEHRE MIT VERSTELLUNG / GONIOMETRO CON LAME MOVIBILI / VERSTELBARE HOEKMETER GONIÓMETRO COM FOLHA DESLIZANTE

| COD | A (mm) | L (mm) | Precisión Accuracy | OP | Funda cuero/Leather bag |
|-------|--------|--------|--------------------|-----|-------------------------|
| 65823 | 100 | 150 | 1° | 250 | 1 |
| 65824 | 150 | 300 | | 360 | |
| 65825 | 200 | 400 | | 480 | |

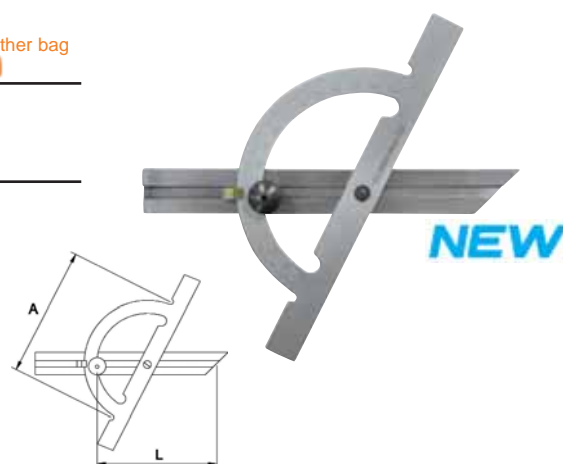

REGLAS FLEXIBLES DE ACERO INOXIDABLE / FLEXIBLE STAINLESS STEEL RULERS REGLETS EN ACIER INOX / FLEXIBLER MASSTAB ROSTFREI STAHL / RIGA FLESSIBILE IN ACCIAIO INOX / RVS MAATLAT / RÉGUAS FLÉXIVEIS EM AÇO INOXIDÁVEL

GRADUACION EN MILÍMETROS / MILIMETRIC GRADUATION / GRADUATION EN MILLIMÈTRE / MM -TEILUNGEN / GRADUAZIONE IN MILLIMETRI / VERDELING IN MM / GRADUAÇÃO EM MILÍMETROS

| COD | L x W (mm) | | | |
|-------|------------|-----|-----|---|
| 65772 | 150x18 | 0.8 | 10 | 6 |
| 65832 | 200x18 | | 12 | |
| 65774 | 300x25 | 1.0 | 20 | |
| 65834 | 500x30 | 1.2 | 40 | |
| 65836 | 600x30 | | 50 | |
| 65838 | 1000x32 | 1.5 | 100 | |
| 65840 | 1200x35 | 1.8 | 125 | |
| 65842 | 1500x38 | | 150 | |
| 65844 | 2000x40 | 2.0 | 200 | |

Resolucion: 1/2mm" / Resolution: 1/2mm / Résolution : 1/2 mm

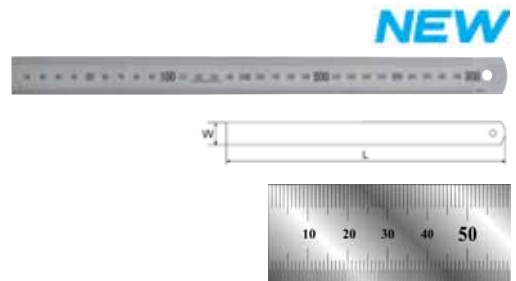

GRADUACION EN MILÍMETROS Y PULGADAS / GRADUATION IN MILLIMETERS AND INCHES / GRADUATION EN MM ET EN POUCE INCH UND MM TEILUNGEN / GRADUAZIONE IN MM E IN POLLICI / VERDELING IN MM EN INCH / GRADUAÇÃO EM MILÍMETROS E POLEGADAS

| COD | L x W (mm) | | | |
|-------|------------|-----|-----|---|
| 65831 | 150x18 | 0.8 | 10 | 6 |
| 65773 | 200x18 | | 12 | |
| 65833 | 300x25 | 1.0 | 20 | |
| 65835 | 500x30 | 1.2 | 40 | |
| 65837 | 600x30 | | 50 | |
| 65839 | 1000x32 | 1.5 | 100 | |
| 65841 | 1200x35 | 1.8 | 125 | |
| 65843 | 1500x38 | | 150 | |
| 65845 | 2000x40 | 2.0 | 200 | |

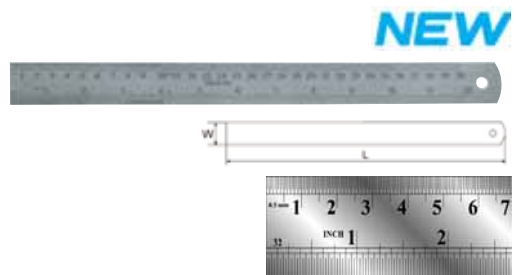

REGLAS DE MADERA / WOODEN RULER / REGLE EN BOIS / GLIEDERMASSTÄBE RIGA IN LEGNO / HOUTEN DUIMSTOCK / RÉGUAS DE MADEIRA

| COD | Longitud / Length m | Color / Colour | | |
|-------|---------------------|---------------------------------|-----|---|
| 65826 | 2 | Natural/Nature | 150 | 6 |
| 65827 | | Blanco/White | | |
| 65828 | | Amarillo/Yellow | | |
| 65829 | | Blanco-Amarillo White-Yellow | | |
| 65830 | 1 | Blanco/White | 75 | |



GALGAS / GAUGES / JAUGES / FÜHLERLEHRE / GALGAS / PRECISIE VOELERMATEN
 GALGAS

GALGAS DE ESPORES / FEELER GAUGE / JAUGES D'ÉPAISSEUR / FÜHLERLEHREFÄCHER / GALGAS DE ESPORES
 VOELERMAAT / APALPA-FOLGAS

| COD | HOJAS BLADES | mm | RANGO-RANGE mm | 9° | |
|-------|-----------------|-----|-------------------|----------|---|
| 65550 | 8 | 150 | 0.05-0.5 | 80 | 6 |
| 65551 | 13 | | 0.05-1.00 | 115 | |
| 65552 | 20 | | | 125 | |
| 65553 | 8 | 200 | | 0.05-0.5 | |
| 65554 | 13 | | 0.05-1.00 | 90 | |
| 65555 | 20 | | | 156 | |
| 65556 | 8 | 300 | 0.05-0.5 | 100 | |
| 65557 | 13 | | 0.05-1.00 | 173 | |
| 65558 | 20 | | | 300 | |



Material: acero templado / Material: Hardened Steel / Matériau : acier endurci

GALGAS DE ESPORES DE PRECISION / PRECISION FEELER GAUGE / JAUGES D'ÉPAISSEUR DE PRÉCISION
 PRÄZISION FÜHLERLEHREFÄCHER / SPESSIMETRI DI PRECISIONE / PRECISIE VOELERMAAT / APALPA FOLGAS DE PRECISÃO

| COD | HOJAS BLADES | mm | RANGO-RANGE mm | 9° | |
|-------|-----------------|-----------|-------------------|-----|---|
| 65559 | 8 | 100 | 0.03-0.10 | 20 | 6 |
| 65560 | 10 | | 0.05-0.50 | 30 | |
| 65562 | 13 | | 0.10-1.00 | 60 | |
| 65563 | 15 | | | 70 | |
| 65564 | 18 | | 0.05-1.00 | 80 | |
| 65565 | 20 | | | 90 | |
| 65566 | 21 | | | 100 | |
| 65567 | 20 | | 0.10-2.00 | 90 | |
| 65568 | 21 | | 0.10-0.50 | 100 | |
| 65569 | 21 | | 0.05-2.00 | 100 | |
| 65570 | 32 | 0.03-1.00 | 210 | | |



Material: acero templado / Material: Hardened Steel / Matériau : acier endurci
 Con tuerca de bloqueo / With lock nut / Avec écrou auto bloquant

GALGAS PARA TOBERAS / NOZZLE GAUGES / JAUGES DE TUYERE / DÜSENLEHRE / GALGAS PARA TOBERAS / SPROEIERME-
 TER / GALGA PARA DIAMETROS INTERIORES

| COD | HOJAS BLADES | RANGO-RANGE mm | 9° | |
|-------|-----------------|-------------------|----|---|
| 65776 | 20 | 0.45-1.50 | 20 | 6 |
| 65777 | | 1.50-3.00 | | |
| 65778 | 16 | 3.00-4.50 | | |
| 65779 | | 4.50-6.00 | | |

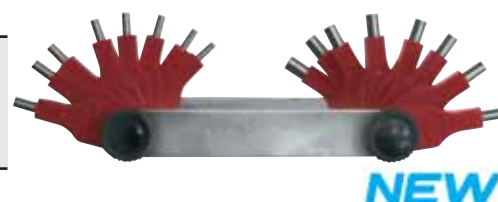

GALGAS PARA RADIOS / RADIUS GAUGES / JAUGES POUR RADIOS / RADIENSCHABLONEN / GALGAS PARA RADIOS / RADIUSMETER / MEDIDOR DE RAIOS

| COD | HOJAS BLADES | RANGO/RANGE (mm) | RF | |
|-------|--------------|------------------|-----|---|
| 65578 | 17 | 1.0-7.0 | 65 | 6 |
| 65579 | 16 | 7.5-15 | 100 | |
| 65580 | 15 | 15.5-25 | 110 | |

| COD | HOJAS BLADES | RANGO/RANGE (inch) | RF | |
|-------|--------------|--------------------|-----|---|
| 65581 | 15 | 1/32"-1/4" | 110 | 6 |
| 65582 | 16 | 17/64"-1/2" | 100 | |
| 65583 | | 17/32"-1" | | |

Material: acero templado / Material: Hardened Steel / Matériau : acier endurci



NEW

GALGAS PARA ANGULOS / ANGLE GAUGES / JAUGE D'ANGLE / WINKELMESSER / GALGAS PARA ANGULOS / HOEKMETERS / MEDIDOR DE ÂNGULOS

| COD | HOJAS BLADES | RANGO/RANGE | RF | |
|-------|--------------|-------------|-----|---|
| 65584 | 20 | 1°-45° | 110 | 6 |



NEW

GALGAS PARA ROSCAS / THREAD PITCH GAUGES / JAUGE POUR FILETAGE / GEWINDESCHABLONEN / GALGAS PARA ROSCAS / SCHROEFDRAADMETER / CONTA FIOS DE ROSCA

| COD | HOJAS BLADES | P(mm) | RF | |
|-------|--------------|-----------|----|---|
| 65571 | 24 | 0.25-6.00 | 40 | 6 |
| 65576 | 12 | 2.00-20.0 | 25 | |

Material: acero templado / Material: Hardened Steel / Matériau : acier endurci
 Tipo de rosca: Metrica 60° / Screwtype: Metric 60° / Type de filetage : métrique 60°



NEW

| COD | HOJAS BLADES | TPI | RF | |
|-------|--------------|------|----|---|
| 65572 | 28 | 4-62 | 42 | 6 |
| 65573 | 6 | 8-28 | 15 | |
| 65574 | 30 | 4-42 | 50 | |
| 65575 | | 6-60 | | |
| 65577 | 16 | 1-12 | 30 | |

Material: acero templado / Material: Hardened Steel / Matériau : acier endurci
 Tipo de rosca: Whitworth 55° / Screwtype: Whitworth 55° / Type de filetage : Withworth 55°



METRICA (ISO) 60°
&
WHITWORTH 55°

AGUJAS DE TRAZAR / SCRIBER / POINTE A TRACER / REISSNADEL / PUNTA PER TRACCIARE KRASPEN / RISCADORES DE TRAÇAR

| | | | | | |
|------------|-----|---------------------|----|---|------------|
| COD | | | | | NEW |
| 65602 | 175 | Moleteado / Knurled | 10 | 6 | |
| COD | | | | | NEW |
| 65603 | 250 | Moleteado / Knurled | 15 | 6 | |
| COD | | | | | NEW |
| 65604 | 230 | Plástico / Plastic | 20 | 6 | |

AGUJA DE TRAZAR DE BOLSILLO / POCKET SCRIBER / POINTE A TRACER DE POCHE / TASCHE-REISSNADEL / PUNTA PER TRACCIARE TASCABILE / ZAKSCHRIJFNAALD / RISCADORES DE TRAÇAR DE BOLSO

| | | | | | |
|------------|-----|---|---|---|------------|
| COD | | | | | NEW |
| 65767 | 150 | 6 | 6 | 6 | |

Punta de carburo de tungsteno / Tungsten carbide point

SET DE MEDICION / MEASUREMENT SET / SET DE MESURE / MASSSATZ / ASSORTIMENTO DI MISURA / METING SET / CONJUNTO DE MEDIÇÃO

| COD | Composición / Composition | | | NEW |
|------------|----------------------------------|--|-----|------------|
| 65782 | 65605 | Compás plano 150mm Divider 150mm | 540 | |
| | 65675 | Escuadra 100x70 din875/1 100x70 square din875/1 | | |
| | 65603 | Aguja de trazar 250mm 250mm scriber | | |
| | 65772 | Regla flexible inoxidable 150mm Flexible inox ruler 150mm | | |



RECOGEDORES TELESCOPICOS / TELESCOPIC JOINT PICK UP / DOIGT MAGNETIQUE TELESCOPIQUE / TELESKOP MAGNETHEBER / TELESCOPIO PRENSILE TELESCOPISCHE MAGNEETHEFFER / RECOLHEDORES TELESCÓPICOS

ARTICULADO / JOINT / ARTICULE / HANDMAGNETHEBER / SNODATO / MAGNEETHEFFER / ARTICULADO

| COD | MAX L mm | Kg CAP | Mango / Handle | |
|----------|----------------|-----------|--------------------|---|
| A- 65588 | 510 | 0,45 | Plástico / Plastic | 6 |
| B- 65589 | 658 | 2,25 | | |



| COD | MAX L mm | Kg CAP | Mango / Handle | |
|-------|----------------|-----------|----------------|---|
| 65590 | 475 | 0,45 | Pen clip | 6 |



CON CLIP DE BOLSILLO / POCKET CLIP / POCHE À CLIPS / ANSTECKCLIP / CON CLIP TASCABILE / COM CLIP DE BOLSO

| COD | Ø | MAX L mm | Kg CAP | | |
|-------|----|----------------|-----------|--|---|
| 65591 | 7 | 635 | 0,68 | | 6 |
| 65592 | 9 | 535 | 0,91 | | |
| 65593 | 10 | 610 | 2,25 | | |
| 65594 | | 615 | 3,62 | | |
| 65595 | | 4,53 | | | |



| COD | Ø | MAX L mm | Kg CAP | | |
|-------|----|----------------|-----------|--|---|
| 65596 | 7 | 635 | 0,68 | | 6 |
| 65597 | 9 | 535 | 0,91 | | |
| 65598 | 10 | 610 | 2,25 | | |
| 65599 | | 615 | 3,62 | | |
| 65600 | | 4,53 | | | |



RECOGEDOR TELESCÓPICO Y AGUJA DE DIBUJAR (2 IN 1) / TELESCOPIC JOINT PICK UP AND POCKET SCRIBER (2 IN 1) / DOIGT MAGNETIQUE TELESCOPIQUE A TRACER / TELESKOP MAGNETHEBER UND REISSNADEL, TASCHMODELL(2 IN 1) / PRENSILE TELESCOPICO E PUNTA PER TRACCIARA DUE IN UNO / TELESCOPISCHE MAGNEETHEFFER EN KRASPEN (2 IN 1) / RECOLHEDOR TELESCÓPICO E RISCADOR DE TRAÇAR (2 EM 1)

| COD | Ø | MAX L mm | Kg CAP | |
|-------|---|----------------|-----------|---|
| 65601 | 7 | 650 | 0,45 | 6 |

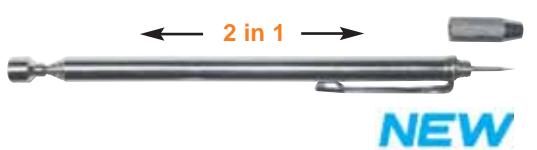

ESPEJOS DE INSPECCION TELESCOPICA ARTICULADOS / TELESCOPIC JOINT INSPECTION MIRROR / MIROIR D'INSPECTION TELESCOPIQUE / TELESKOPISCHE SUCHSPIEGEL TELESCOPIO SNODATO PER ISPEZIONI A SPECCHIO / TELESCOPISCHE INSPECTIESPIEGEL ESPELHOS DE INSPECÇÃO TELESCÓPICOS ARTICULADOS

| COD | MAX L mm | Ø | Kg CAP | | |
|-------|----------------|----------|-----------|--------------------|---|
| 65585 | 550 | 3,5 x 2" | 45 | Plástico / Plastic | 6 |



| COD | MAX L mm | Ø | Kg CAP | | |
|-------|----------------|------|-----------|--------------------|---|
| 65586 | 750 | Ø 2" | 65 | Plástico / Plastic | 6 |



| COD | MAX L mm | Ø | Kg CAP | Mango / Handle | |
|-------|----------------|---------|-----------|----------------|---|
| 65587 | 502 | Ø 1,25" | 55 | Pen clip | 6 |



JUEGOS DE GOLPE / PUNCHES / JEUX DE CLES A CHOC / DURCHSCHLÄGE / PUNZONI DOORSLAG / JOGOS DE PANCADA

LETRAS / LETTERS / LETTRES / BUCHSTABEN / LETTERE / LETTERS / LETRAS

| COD | Altura / Hight (mm) | A mm | B mm | C mm | 9F |
|-------|---------------------|------|------|------|------|
| 65847 | 2 | 56 | 6.4 | 6.4 | 650 |
| 65848 | 3 | | | | 660 |
| 65849 | 4 | 63 | 8 | 8 | 680 |
| 65850 | 5 | | | | 900 |
| 65851 | 6 | 68 | 9.2 | 9.2 | 1100 |

DIN 1451

NEW

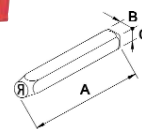

NUMEROS / NUMBERS / NUMÉROS / NUMMER / NUMERI / NUMMERS / NÚMEROS

| COD | Altura / Hight (mm) | A mm | B mm | C mm | 9F |
|-------|---------------------|------|------|------|-----|
| 65852 | 2 | 56 | 6,4 | 6,4 | 210 |
| 65853 | 3 | | | | 220 |
| 65854 | 4 | 63 | 8 | 8 | 230 |
| 65855 | 5 | | | | 300 |
| 65856 | 6 | 68 | 9,2 | 9,2 | 400 |

DIN 1451

NEW



EGA Master S.A.

ART IN INNOVATION

La más galardonada

The most awarded

La plus primée



 1.000V
IEC 900 resp.
DIN EN 60 900



EGA Master ofrece una extensísima colección de herramientas de seguridad aisladas 1000V: alicates, destornilladores, llaves ajustables, cortacables de carraca, pinzas, cuchillos, tenazas, llaves fijas y de estrella, llaves de vaso (con sus correspondientes accesorios y juegos), arcos de sierra, etc.

EGA Master offers a huge range of safety 1000v insulated handtools: pliers, screwdrivers, adjustable wrenches, tweezers, knives, sockets, spanners, hacksaws...

EGA Master offre une vaste gamme d'outils isolés 1000v : pinces, tournevis, clés réglables, brucelles, couteaux, douilles, clés, scies à métaux...



TEST DE IMPACTO
IMPACT TEST
TEST D'IMPACT

 **1.000V**
IEC 900 resp.
DIN EN 60 900

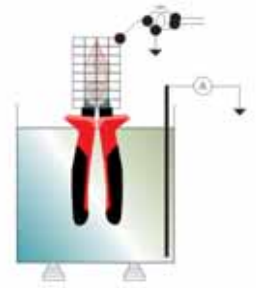

TEST DIELÉCTRICO A 10.000V
DIELECTRIC TEST AT 10.000V
TEST DIELECTRIQUE À 10.000V



TEST DE ADHERENCIA DE MANGOS
TESTING OF ADHESIVENESS
TEST D'ADHERENCE
KLEBTEST



TEST DE PENETRACIÓN
PENETRATION TEST
TEST DE PENETRATION



TEST DE NO PROPAGACION DE LLAMA
HEAT RESISTANCE TEST
TEST DE COMBUSTIBILITE

Las herramientas aisladas de EGA Master cumplen con la normativa IEC 900 resp. DIN EN 60900, siendo sometidas todas ellas al test dieléctrico a 10.000 V (es decir, a una intensidad 10 veces mayor de la certificada). Las herramientas son objeto también de los tests de adherencia, penetración dieléctrica, impacto y propagación de llama, de acuerdo a la rigurosa norma europea.

EGA Master insulated tools comply with IEC 900 resp. DIN EN 60900 international standard, each one of the pieces being tested at 10,000V (10 times the voltage we certify). They are also tested rigorously according to what the norms establishes: adherence test, impact test, flame propagation test and dielectric penetration test.

Les outils isolés de EGA Master sont conformes aux normes du CEI 900 ainsi que la norme internationale DIN EN 60900. Chacunes des pièces sont testées à 10.000V (nous certifions 10 fois la tension). Elles sont rigoureusement testées suivant les normes établisent: essai d'adhérence, essai au choc, essai de propagation de flamme et essai de pénétration de diélectrique.



1 El doble aislamiento de PVC duro-blando ofrece máxima adherencia y seguridad ante posibles imprevistos / **Double hard-soft PVC insulation provides maximum adherence and safety** / **La double isolation de PVC Dur-souple offre une adhérence optimale et une sécurité contre les imprévus.**



2 Guardamanos y extremidades anti-choque / **Anti-shock guards and ends.** / **Poignées et extrémités anti-chocs.**

3 Marcado láser indeleble / **Un-erasable laser marking /** **Marquage Laser indélébile.**

PRINCIPALES CAMPOS DE APLICACIÓN / MAIN APPLICATION FIELDS / PRINCIPALES DOMAINES D'APPLICATION

| | | |
|---|---|---|
| Instaladores electricos / Electrical installation Electriciens | Redes de alta tension / High Voltage networks Réseaux hautes tensions | Industria química / Chemical Industry Industrie chimique |
| Centrales Electricas / Power Plants Centrales electriques | Redes de baja tension / Low Voltage networks Réseaux en basse tension | Bomberos / Fire-fighters / Pompiers |
| Estaciones y subestaciones electricas Electric Stations and substations Stations et subdivisions électriques | Telecomunicaciones / Telecommunications Télécommunications | Instalacion y reparacion de alumbrado Lighting installation and repair Voiries et réseaux divers (VRD) |

PRECAUCIONES / CAUTION / PRÉCAUTIONS

1 No emplear nunca la herramienta en aplicaciones bajo tensión si la protección presenta poros, fisuras, elementos incrustados o se ve la capa inferior de color blanco / **Don't ever use tools under voltage if they present pores, fissures, encrusted elements or if the white insulation layer is visible** / **Ne jamais utiliser l'outillage en tension si la protection semble poreuse, présente des fissures, que des corps étrangers sont incrustés ou que la couche inférieure est blanche.**

2 Se recomienda emplear suelos aislantes y calzado de seguridad en trabajos bajo tensión / **Insulating floors and safety shoes are recommended to work under voltage**

3 Evite el contacto con agua mientras realice trabajos bajo tensión / **Avoid contact with water while working under voltage / Il est recommandé d'utiliser lors du travail sous tension , un tapis d'isolation et des chaussures á semelles diélectriques**





4 No tocar directamente ninguna pieza susceptible de estar bajo tensión. Emplear un comprobador de tensión o tester / **Do not ever touch directly any item that may be under voltage. Use a voltage tester to check first / Ne jamais toucher directement , une pièce susceptible d'être sous tension.**



ALICATES / PLIERS / PINCES / ZANGEN / PINZE / UITVOERING / ALICATES





MASTERCUT TITACROM BIMAT 1000V

UNIVERSALES / COMBINATION / UNIVERSELLES / KOMBIZANGEN / UNIVERSALE / COMBINATIETANG / UNIVERSAIS



| COD |  |  |  |  |
|-------|---|---|---|---|
| 62510 | 160 | 220 | | |
| 62511 | 180 | 230 | | |
| 62512 | 200 | 280 | | |
| 62483 | 210 | 290 | 6 | 1 |
| 62488 | 220 | 310 | | |
| 62484 | 235 | 380 | | |

1.000V
IEC 900 resp.
DIN EN 60 900

TELEFONISTA / LONG NOSE / TELEPHONE / TELEFONZANGEN / TELEFONISTI / TELEFOONTANG / TELEFONISTA

| COD |  |  |  |  |
|-------|---|---|---|---|
| 62778 | 160 | 170 | | |
| 62779 | 200 | 210 | 6 | 1 |



1.000V
IEC 900 resp.
DIN EN 60 900TELEFONISTA BOCA CURVA / BENT NOSE PLIERS / TELEPHONE BECS COUDES / TELEFONZANGEN GEBOGEN
TELEFONISTI BECCHI PIEGATI / RADIO TANG MET GEBOGEN BEKKEN / TELEFONISTA PONTAS CURVAS

| COD |  |  |  |  |
|-------|---|---|---|---|
| 62780 | 160 | 170 | | |
| 62781 | 200 | 210 | 6 | 1 |

1.000V
IEC 900 resp.
DIN EN 60 900CORTE DIAGONAL / DIAGONAL CUTTING PLIERS / COUPANTES DIAGONALES / KRAFTSEITENSCHNEIDER / TAGLIO LATERALE
ZIKNIPTANG / CORTE DIAGONAL

| COD |  |  |  |  |
|-------|---|---|---|---|
| 62782 | 160 | 210 | | |
| 62783 | 190 | 245 | 6 | 1 |





1.000V
IEC 900 resp.
DIN EN 60 900CORTE DIAGONAL REFORZADO / HEAVY DUTY CUTTING NIPPERS / COUPANTES RENFORCEES / KRAFTSEITENSCHNEIDER
TAGLIO LATERALE RINFORZATO / ZIKNIPTANG-VERSTERKT / CORTE DIAGONAL REFORÇADO

| COD |  |  |  |  |
|-------|---|---|---|---|
| 62784 | 180 | 350 | 6 | 1 |





1.000V
IEC 900 resp.
DIN EN 60 900

TITACROM BIMAT 1000V

UNIVERSALES / COMBINATION / UNIVERSELLES / KOMBIZANGEN / UNIVERSALE / COMBINATIETANG / UNIVERSAIS

| COD |  |  |  |  |
|-------|---|---|---|---|
| 62371 | 160 | 235 | | |
| 62372 | 180 | 275 | | |
| 62373 | 200 | 330 | 6 | 1 |
| 62481 | 210 | 385 | | |

1.000V
IEC 900 resp.
DIN EN 60 900UNIVERSALES CORTE REFORZADO / COMBINATION REINFORCED CUTTING / UNIVERSELLES RENFORCEES / KOMBIZANGEN
UNIVERSALE RINFORZATA / COMBINATIETANG VERSTERKT / UNIVERSAIS CORTE REFORÇADO

| COD |  |  |  |  |
|-------|---|---|---|---|
| 62374 | 160 | 250 | | |
| 62375 | 180 | 200 | 6 | 1 |
| 62376 | 200 | 400 | | |

1.000V
IEC 900 resp.
DIN EN 60 900

BOCA PLANA / FLAT NOSE / PLATES / FLACHZANGEN / BECCHI PIATTI / PLATE TANG / PONTAS CHATAS

| COD |  |  |  |  |
|-------|---|---|---|---|
| 62377 | 160 | 170 | 6 | 1 |

1.000V
IEC 900 resp.
DIN EN 60 900

BOCA REDONDA / ROUND NOSE / RONDES / RUNDZANGEN / BECCHI TONDI / TANG MET GEBOGEN BEKKEN
PONTAS REDONDAS

| COD | | | | |
|-------|-----|-----|---|---|
| 62378 | 160 | 160 | 6 | 1 |

1.000V
IEC 900 resp.
DIN EN 60 900



DIN 5745

TELEFONISTA / LONG NOSE / TELEPHONE / TELEFONZANGEN / TELEFONISTI / TELEFOONTANG / TELEFONISTA

| COD | | | | |
|-------|-----|-----|---|---|
| 62379 | 160 | 170 | 6 | 1 |
| 62380 | 200 | 210 | | |

1.000V
IEC 900 resp.
DIN EN 60 900



DIN 5745

TELEFONISTA BOCA CURVA / BENT NOSE PLIERS / TELEPHONE BECS COUDÉS / TELEFONZANGEN GEBOGEN
TELEFONISTI BECCHI PIEGATI / RADIO TANG MET GEBOGEN BEKKEN / TELEFONISTA PONTAS CURVAS

| COD | | | | |
|-------|-----|-----|---|---|
| 62381 | 160 | 170 | 6 | 1 |
| 62382 | 200 | 210 | | |

1.000V
IEC 900 resp.
DIN EN 60 900



DIN 5745

CORTE DIAGONAL / DIAGONAL CUTTING PLIERS / COUPANTES DIAGONALES / KRAFTSEITENSCHNEIDER
TAGLIO LATERALE / ZIKNIPTANG / CORTE DIAGONAL

| COD | | | | |
|-------|-----|-----|---|---|
| 62383 | 160 | 210 | 6 | 1 |

1.000V
IEC 900 resp.
DIN EN 60 900



DIN 5749

CORTE DIAGONAL REFORZADO / HEAVY DUTY CUTTING NIPPERS / COUPANTES RENFORCEES / KRAFTSEITENSCHNEIDER
TAGLIO LATERALE RINFORZATO / ZIKNIPTANG-VERSTERKT / CORTE DIAGONAL REFORÇADO

| COD | | | | |
|-------|-----|-----|---|---|
| 62384 | 180 | 350 | 6 | 1 |

1.000V
IEC 900 resp.
DIN EN 60 900



DIN 5749

CORTE FRONTAL / END CUTTING NIPPER / COUPANTES DEVANT / VORSCHNEIDER / TAGLIO FRONTALE / KOPKNIPTANG
CORTE FRONTAL

| COD | | | | |
|-------|-----|-----|---|---|
| 62385 | 160 | 250 | 6 | 1 |

1.000V
IEC 900 resp.
DIN EN 60 900



DIN 5748

CORTE FRONTAL ELECTRICISTA / END CUTTING NIPPER (ELECTRICIAN) / COUPANTES DEVANT ELECTRICIEN
ELEKTRIKER VORSCHNEIDER / TAGLIO FRONTALE PER ELETTRICIST / KOPKNIPTANG ELECTRIEKER / CORTE FRONTAL
ELECTRICISTA

| COD | | | | |
|-------|-----|-----|---|---|
| 62386 | 160 | 250 | 6 | 1 |
| 62387 | 180 | 300 | | |
| 62388 | 200 | 410 | | |

1.000V
IEC 900 resp.
DIN EN 60 900



DIN 5748

PELACABLES / WIRESTRIPPER / PINCES A DENUDER / ABISOLIERZANGEN / PINZE SPELAFILI / STRIPTANG / DECAPARADORES

| COD | | | | |
|-------|-----|-----|---|---|
| 62389 | 160 | 170 | 6 | 1 |

1.000V
IEC 900 resp.
DIN EN 60 900



DIN 5743

KIT

| COD | | | | |
|----------|----------|-----|---|---|
| A: 68500 | TITACROM | 180 | 6 | 1 |
| B: 68501 | | 160 | | |
| | | 160 | | |



NEW

CORTACABLES ELECTRICO / CABLECUTTER / COUPE CABLE / KABELSCHNEIDER TAGLIACAVI ELETTRICO / KABELSCHAAR

| COD | L mm | mm | mm | mm |
|-------|------|-----|----|----|
| 73000 | 220 | 460 | 6 | 1 |



1.000V
IEC 900 resp.
DIN EN 60 900

ELECTRICIDAD / ELECTRICIAN TOOLS / OUTILLAGE D'ELECTRICIEN ELEKTRIKERMESSEER / ELECTRICIENSMES / FERRAMENTI PER ELETTRICISTI

CORTACABLES DE CARRACA / RATCHET ELECTRICIAN CABLE CUTTER / COUPE-CABLES A CLIQUET / KABELSCHNEIDER MIT RATSCHEN / KABLESNIJDER MET RATEL / TAGLIACAVI CRICCO PER ELETTRICI / CORTA CABOS DE ROQUETE PARA ELECTRICISTA

| COD | mm | L mm | mm | mm |
|-------|----|------|-----|----|
| 73010 | 32 | 260 | 610 | 6 |
| 73011 | 52 | 280 | 800 | |



1.000V
IEC 900 resp.
DIN EN 60 900

PINZAS / TWEEZERS / BRUCELLES / GREIFPINZETTEN / PINZETTE DI PRECISIONE / PINCETTEN / PINÇAS

| COD | L mm | mm | mm | mm |
|-------|------|----|----|----|
| 73040 | 115 | 15 | 12 | 1 |



1.000V
IEC 900 resp.
DIN EN 60 900

| COD | L mm | mm | mm | mm |
|-------|------|----|----|----|
| 73041 | 120 | 15 | 12 | 1 |



1.000V
IEC 900 resp.
DIN EN 60 900

CUCHILLOS / KNIFES / COUTEAUX / MESSER / LAME / MESSEN

| COD | L mm | mm | mm |
|-------|------|----|----|
| 73035 | 170 | 70 | 12 |



1.000V
IEC 900 resp.
DIN EN 60 900

| COD | L mm | mm | mm |
|-------|------|----|----|
| 73036 | 200 | 70 | 12 |



1.000V
IEC 900 resp.
DIN EN 60 900

TENAZAS / PLIERS / ZANGE / TENAILLES / TENAGLIE / NIPTANG / ALICATES

TENAZA DE CANAL / BOX JOINT / MULTIPRISE ENTREPASSEE / WASSERPUMPENZANGE / PINZE REGULABILI
WATERPOMPTANG / BICO DE PAPAGAIO

| COD | L | g | mm | mm |
|-------|-----|-----|----|----|
| 73004 | 10" | 400 | 6 | 1 |
| 73005 | 12" | 615 | 6 | 1 |

1.000V
IEC 900 resp.
DIN EN 60 900



PICO DE LORO / GROOVE JOINT / MULTIPRISE A CREMAILLERE / WASSERPUMPENZANGE / PINZE REGULABILI
WATERPOMPTANG MET RILLENVERSTELLING / BICO DE PAPAGAIO

| COD | L | g | mm | mm |
|-------|-----|-----|----|----|
| 73001 | 10" | 450 | 6 | 1 |

1.000V
IEC 900 resp.
DIN EN 60 900



TENAZAS CORTACABLES / CABLE CUTTERS / COUPE-CABLES / KABELSCHNEIDER / CESCOIE PER CAVI / KABELSNIJDERS
TESOURAS CORTA CABOS

| COD | L mm | g | mm | mm |
|-------|------|-----|----|----|
| 73008 | 220 | 500 | 6 | 1 |
| 73009 | 600 | 900 | 6 | 1 |

1.000V
IEC 900 resp.
DIN EN 60 900



CORTAVARILLAS / BOLT CUTTERS / COUPE-BOULONS / BOLZENSCHNEIDER / BOUTENSCHAREN / TAGLIABULLONI
CORTA VARÃO

| COD | L | CAP 50Kg/mm ² 140Kg/mm ² | Kg. | mm |
|-------|-----|---|-----|----|
| 73020 | 18" | 8-6 | 1,7 | 1 |
| 73021 | 24" | 10-8 | 2,7 | 1 |

1.000V
IEC 900 resp.
DIN EN 60 900



LLAVES AJUSTABLES / ADJUSTABLE WRENCHES / CLES A MOLETTE / ROLLGABELSCHLÜSSELS CHAVI REGOLABILI A RULLINO / VERSTELBARE SLEUTELS CHAVES AJUSTAVELS

LLAVES AJUSTABLES / ADJUSTABLE WRENCHES / CLES A MOLETTE / ROLLGABELSCHLÜSSELS

TITACROM®



1.000V
IEC 900 resp.
DIN EN 60 900

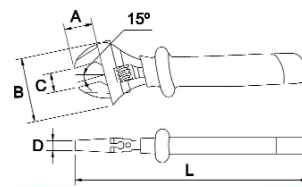

| COD | L | A | B | C | D | g | mm | mm |
|-------|-----|----|----|-------|------|-----|----|----|
| 61984 | 6" | 20 | 47 | 19,2 | 6,5 | 200 | 6 | 1 |
| 61985 | 8" | 25 | 57 | 24,05 | 7,2 | 365 | | |
| 61986 | 10" | 30 | 70 | 28,78 | 8,4 | 615 | | |
| 61987 | 12" | 35 | 84 | 33,55 | 10,2 | 970 | | |

FOSFATADA / PHOSPHATED / PHOSPHATEE BRUNIE / PHOSPHATIERT/ FINITURA BRUNITA / ZWART / BRUNIDA



1.000V
IEC 900 resp.
DIN EN 60 900

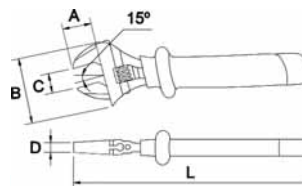

| COD | L | A | B | C | D | g | mm | mm |
|-------|-----|----|----|-------|------|------|----|----|
| 61988 | 6" | 20 | 47 | 19,2 | 6,5 | 195 | 6 | 1 |
| 61989 | 8" | 25 | 57 | 24,05 | 7,2 | 370 | | |
| 61990 | 10" | 30 | 70 | 28,78 | 8,4 | 645 | | |
| 61991 | 12" | 35 | 84 | 33,55 | 10,2 | 1030 | | |

ALAVESA / BASQUE / BASKISCH / BASCA / TYPE BASK

PATENTADA / PATENTED / BREVETEE / PATENTIERT / BREVETTATO / GEPATENTERD / PATENTEADA
SISTEMA DE ACCION RAPIDA / QUICK ACTION SYSTEM / ACTION RAPIDE / SCHNELLVERSTELLUNG
SISTEMA DE AZIONE RAPIDA / SNELVERSTELLING / SISTEMA DE ACÇÃO RAPIDA

TITACROM®



1.000V
IEC 900 resp.
DIN EN 60 900

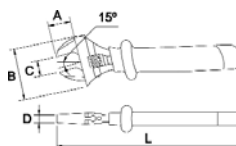

| COD | L | A | B | C | D | | | |
|-------|-----|----|----|------|------|------|---|---|
| 61992 | 6" | 20 | 47 | 19 | 6,5 | 195 | 6 | 1 |
| 61993 | 8" | 25 | 57 | 24 | 7,2 | 370 | | |
| 61994 | 10" | 30 | 70 | 29 | 8,4 | 645 | | |
| 61995 | 12" | 35 | 84 | 33,5 | 10,2 | 1030 | | |

FOSFATADA / PHOSPHATED / PHOSPHATEE BRUNIE / PHOSPHATIERT / FINITURA BRUNITA / ZWART / BRUNIDA



1.000V
IEC 900 resp.
DIN EN 60 900

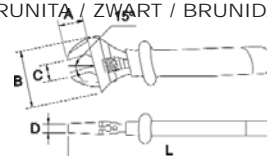

| COD | L | A | B | C | D | | | |
|-------|-----|----|----|------|------|------|---|---|
| 61996 | 6" | 20 | 47 | 19 | 6,5 | 195 | 6 | 1 |
| 61997 | 8" | 25 | 57 | 24 | 7,2 | 370 | | |
| 61998 | 10" | 30 | 70 | 29 | 8,4 | 645 | | |
| 61999 | 12" | 35 | 84 | 33,5 | 10,2 | 1030 | | |

LLAVE COMBI / WRENCH COMBI / CLE COMBI / ROLLGABELSCHLÜSSEL COMBI

TITACROM®



1.000V
IEC 900 resp.
DIN EN 60 900

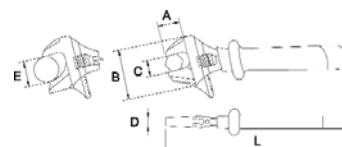

| COD | L | A | B | C | D | E | | | |
|-------|-----|----|------|-------|------|-------|------|---|---|
| 61976 | 10" | 30 | 68,5 | 28,78 | 8,4 | 1.1/4 | 645 | 6 | 1 |
| 61977 | 12" | 35 | 82 | 33,55 | 10,2 | 1.1/2 | 1030 | | |

FOSFATADA / PHOSPHATED / PHOSPHATEE BRUNIE / PHOSPHATIERT / FINITURA BRUNITA / ZWART / BRUNIDA



1.000V
IEC 900 resp.
DIN EN 60 900

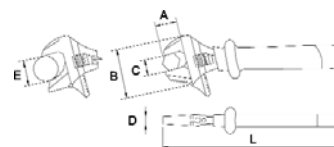

| COD | L | A | B | C | D | E | | | |
|-------|-----|----|------|-------|------|-------|------|---|---|
| 61978 | 10" | 30 | 68,5 | 28,78 | 8,4 | 1.1/4 | 645 | 6 | 1 |
| 61979 | 12" | 35 | 82 | 33,55 | 10,2 | 1.1/2 | 1030 | | |

Las ajustables aisladas a 1000V no se pueden homologar ya que la moleta no puede ser aislada, por lo tanto no se puede garantizar la seguridad del usuario, aunque el material aislante cumple la norma EN-60900 en cuanto a resistencia eléctrica.

The insulated adjustable wrenches 1000V can not be homologated as the wheel nut can not be insulated. The safety of the user can not be guaranteed, even though the insulated material fulfils the requirements of the norm EN-60900 regarding the electrical resistance.

Les clés à molette isolées 1000 V ne peuvent être homologuées, la molette ne pouvant être isolée, nous ne pouvons garantir la sécurité de l'utilisateur, malgré que le matériau isolant est conforme à la norme EN-60900 sur la résistance électrique.

ALAVESA COMBI / BASQUE COMBI / BASKISCHER KOMBI / BASCA COMBI / TYPE BASK COMBI

PATENTADA / PATENTED / BREVETEE / PATENTIERT / BREVETTATO / GEPATENTERD / PATENTEADA

SISTEMA DE ACCION RAPIDA / QUICK ACTION SYSTEM / ACTION RAPIDE / SCHNELLE AKTION / SISTEMA DE AZIONE RAPIDA / SNELVERSTELLING / SISTEMA DE ACÇÃO RAPIDA



TITACROM®

1.000V
IEC 900 resp.
DIN EN 60 900

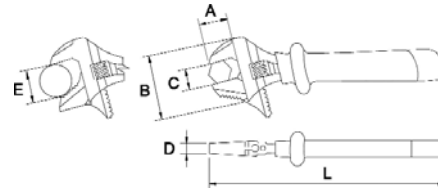

| COD | L | A | B | C | D | E | gr. | | |
|-------|-----|----|------|-------|------|-------|------|---|---|
| 61128 | 10" | 30 | 68,5 | 28,78 | 8,4 | 1.1/4 | 645 | 6 | 1 |
| 61129 | 12" | 35 | 82 | 33,55 | 10,2 | 1.1/2 | 1030 | 6 | 1 |

FOSFATADA / PHOSPHATED / PHOSPHATEE BRUNIE / PHOSPHATIERT / FINITURA BRUNITA / ZWART / BRUNIDA

1.000V
IEC 900 resp.
DIN EN 60 900

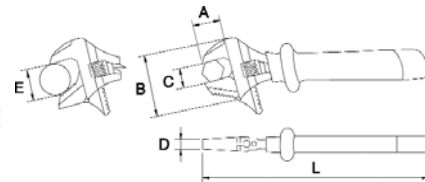

| COD | L | A | B | C | D | E | gr. | | |
|-------|-----|----|------|-------|------|-------|------|---|---|
| 61130 | 10" | 30 | 68,5 | 28,78 | 8,4 | 1.1/4 | 645 | 6 | 1 |
| 61131 | 12" | 35 | 82 | 33,55 | 10,2 | 1.1/2 | 1030 | 6 | 1 |

LLAVES AJUSTABLES / ADJUSTABLE WRENCHES / CLES A MOLETTE / ROLLGABELSCHLÜSSEL

SCANDINAVIAN TYPE / LEFT TURN

FOSFATADA / PHOSPHATED / PHOSPHATEE BRUNIE / PHOSPHATIERT / FINITURA BRUNITA / ZWART / BRUNIDA

1.000V
IEC 900 resp.
DIN EN 60 900

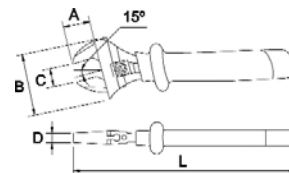

| COD | L | A | B | C | D | E | gr. | | |
|-------|-----|----|----|-------|------|------|-----|---|--|
| 60563 | 6" | 20 | 47 | 19,2 | 6,5 | 195 | 6 | 1 | |
| 60564 | 8" | 25 | 57 | 24,05 | 7,2 | 370 | | | |
| 60565 | 10" | 30 | 70 | 28,78 | 8,4 | 645 | | | |
| 60566 | 12" | 35 | 84 | 33,55 | 10,2 | 1030 | | | |

Las ajustables aisladas a 1000V no se pueden homologar ya que la moleta no puede ser aislada, por lo tanto no se puede garantizar la seguridad del usuario, aunque el material aislante cumple la norma EN-60900 en cuanto a resistencia eléctrica.
The insulated adjustable wrenches 1000V can not be homologated as the wheel nut can not be insulated. The safety of the user can not be guaranteed, even though the insulated material fulfills the requirements of the norm EN-60900 regarding the electrical resistance.
Les clés à molette isolées 1000 V ne peuvent être homologuées, la molette ne pouvant être isolée, nous ne pouvons garantir la sécurité de l'utilisateur, malgré que le matériau isolant est conforme à la norme EN-60900 sur la résistance électrique.

ALAVESA / BASQUE / BASKISCH / BASCA / TYPE BASK

BASQUE SCANDINAVIAN TYPE / LEFT TURN

PATENTADA / PATENTED / BREVETEE / PATENTIERT / BREVETTATO / GEPATENTERD / PATENTEADA
SISTEMA DE ACCION RAPIDA / QUICK ACTION SYSTEM / ACTION RAPIDE / SCHNELLVERSTELLUNG
SISTEMA DE AZIONE RAPIDA / SNELVERSTELLING / SISTEMA DE ACÇÃO RAPIDA



FOSFATADA / PHOSPHATED / PHOSPHATEE BRUNIE / PHOSPHATIERT / FINITURA BRUNITA / ZWART / BRUNIDA

1000V



1.000V
IEC 900 resp.
DIN EN 60 900

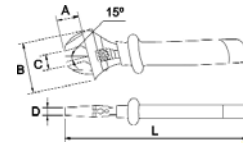

| COD | L | A | B | C | D | gf | | |
|-------|-----|----|----|------|------|------|---|---|
| 60574 | 6" | 20 | 47 | 19 | 6,5 | 195 | 6 | 1 |
| 60575 | 8" | 25 | 57 | 24 | 7,2 | 370 | | |
| 60576 | 10" | 30 | 70 | 29 | 8,4 | 645 | | |
| 60577 | 12" | 35 | 84 | 33,5 | 10,2 | 1030 | | |

LLAVE COMBI / WRENCH COMBI / CLE COMBI / ROLLGABELSCHLÜSSEL COMBI

COMBI SCANDINAVIAN TYPE / LEFT TURN

PATENTADA / PATENTED / BREVETEE / PATENTIERT / BREVETTATO / GEPATENTERD / PATENTEADA



FOSFATADA / PHOSPHATED / PHOSPHATEE BRUNIE / PHOSPHATIERT / FINITURA BRUNITA / ZWART / BRUNIDA



1.000V
IEC 900 resp.
DIN EN 60 900

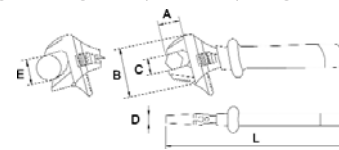

| COD | L | A | B | C | D | E | gf | |
|-------|-----|----|------|-------|------|-------|------|---|
| 61245 | 10" | 30 | 68,5 | 28,78 | 8,4 | 1.1/4 | 645 | 6 |
| 61246 | 12" | 35 | 82 | 33,55 | 10,2 | 1.1/2 | 1030 | |

ALAVESA COMBI / BASQUE COMBI / BASKISCH KOMBI / BASCA COMBI / TYPE BASK COMBI

BASQUE COMBI SCANDINAVIAN TYPE / LEFT TURN

PATENTADA / PATENTED / BREVETEE / PATENTIERT / BREVETTATO / GEPATENTERD / PATENTEADA
SISTEMA DE ACCION RAPIDA / QUICK ACTION SYSTEM / ACTION RAPIDE / SCHNELLE AKTION / SISTEMA DE AZIONE RAPIDA
SNELVERSTELLING / SISTEMA DE ACÇÃO RAPIDA



FOSFATADA / PHOSPHATED / PHOSPHATEE BRUNIE / PHOSPHATIERT / FINITURA BRUNITA / ZWART / BRUNIDA



1.000V
IEC 900 resp.
DIN EN 60 900

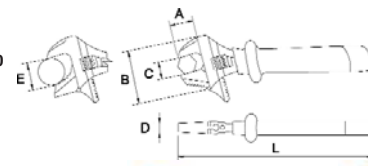

| COD | L | A | B | C | D | E | gf | |
|-------|-----|----|------|-------|------|-------|------|---|
| 60588 | 10" | 30 | 68,5 | 28,78 | 8,4 | 1.1/4 | 645 | 6 |
| 60589 | 12" | 35 | 82 | 33,55 | 10,2 | 1.1/2 | 1030 | |

Las ajustables aisladas a 1000V no se pueden homologar ya que la moleta no puede ser aislada, por lo tanto no se puede garantizar la seguridad del usuario, aunque el material aislante cumple la norma EN-60900 en cuanto a resistencia eléctrica.

The insulated adjustable wrenches 1000V can not be homologated as the wheel nut can not be insulated. The safety of the user can not be guaranteed, even though the insulated material fulfils the requirements of the norm EN-60900 regarding the electrical resistance.

Les clés à molette isolées 1000 V ne peuvent être homologuées, la molette ne pouvant être isolée, nous ne pouvons garantir la sécurité de l'utilisateur, malgré que le matériau isolant est conforme à la norme EN-60900 sur la résistance électrique.

**LLAVES AJUSTABLES / ADJUSTABLE WRENCHES / CLES A MOLETTE / ROLLGABELSCHLÜSSEL
MOLETA LATERAL / LATERAL NUT / MIT SCHNECKENROLLE / MOLETTE LATERALE
RULLINO LATERALE / ZIJ-INSTELLING**

TITACROM® 1000V



1.000V
IEC 900 resp.
DIN EN 60 900

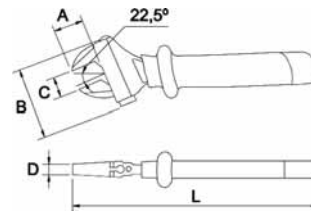

| COD | L | A | B | C | D | gf. | | |
|-------|-----|------|------|-------|------|------|---|---|
| 61132 | 6" | 19,5 | 54,1 | 19,2 | 8,5 | 200 | | |
| 61133 | 8" | 24 | 64,2 | 24,05 | 9,5 | 400 | | |
| 61134 | 10" | 30 | 78,5 | 28,78 | 11,1 | 600 | 6 | 1 |
| 61135 | 12" | 36 | 93,4 | 33,55 | 12,7 | 1000 | | |

LLAVES / WRENCHES / CLES / SCHLÜSSEL / CHIAVI / SLEUTELS / CHAVES

FIJA DE UNA BOCA / SINGLE ENDED OPEN JAW SPANNER / A FOURCHE / EINMAULSCHLÜSSEL / FISSE SEMPLICE
ENKELVOUDIGE STEEKSLEUTEL / FIXA DE UMA BOCA

| COD | | gf. | | |
|-------|----|-----|----|---|
| 73062 | 8 | 20 | | |
| 73063 | 9 | 25 | | |
| 73064 | 10 | 30 | | |
| 73065 | 11 | 35 | | |
| 73066 | 12 | 45 | | |
| 73067 | 13 | 55 | 10 | |
| 73068 | 14 | 60 | | |
| 73069 | 15 | 70 | | 1 |
| 73070 | 16 | 80 | | |
| 73071 | 17 | 95 | | |
| 73072 | 18 | 185 | | |
| 73073 | 19 | 150 | | |
| 73075 | 21 | 185 | | |
| 73076 | 22 | 230 | 5 | |
| 73077 | 24 | 350 | | |
| 73079 | 27 | 370 | | |
| 73082 | 30 | | | |
| 73083 | 32 | | | |

| COD | | gf. | | |
|-------|--------|-----|----|---|
| 73043 | 1/4" | 30 | | |
| 73044 | 9/32" | 30 | | |
| 73045 | 5/16" | 30 | | |
| 73046 | 3/8" | 40 | | |
| 73047 | 7/16" | 45 | | |
| 73048 | 1/2" | 55 | 10 | |
| 73049 | 9/16" | 75 | | 1 |
| 73050 | 5/8" | 100 | | |
| 73051 | 11/16" | 120 | | |
| 73052 | 3/4" | 130 | | |
| 73053 | 13/16" | 180 | | |
| 73054 | 7/8" | 190 | 5 | |
| 73055 | 15/16" | 220 | | |



1.000V
IEC 900 resp.
DIN EN 60 900





KIT DEMO 6 LLAVES / 6 SPANNER DEMO KIT / KIT DÉMO. 6 CLÉS / DEMOKIT 6 SCHLÜSSEL / KIT 6 CHIAVI DI DIMOSTRAZIONE
DEMOKIT 6 SLEUTELS / KIT DEMO 6 CHAVES

| COD | Composicion/Composition | |  |  |
|-------|-------------------------|----------------------|---|---|
| 69342 | 61727 | Cr-V Aeroespacial | 8mm | 300 |
| | 61627 | Cr-V Espejo - Mirror | | |
| | 73062 | Cr-V 1000V | | |
| | 70172 | Cu-Be | | |
| | 70684 | Al-Bron | | |
| | 71669 | Titanium | | |







NEW

LLAVE DE ESTRELLA ACODADA UNA BOCA / OFFSET RING WRENCH / CLE POLYGONALE / GEKRÖPFTE RINGSCHLÜSSEL
CHIAVE A STELLA AD UNA BOCCA / DIEPGEBOGEN RINGSLEUTEL





| COD |  |  |  |  |  |
|-------|---|---|---|---|---|
| 73090 | 6 | 140 | 50 | 10 | 1 |
| 73091 | 7 | 145 | 50 | | |
| 73092 | 8 | 150 | 55 | | |
| 73093 | 9 | 155 | 75 | | |
| 73094 | 10 | 160 | 80 | | |
| 73095 | 11 | 170 | 90 | | |
| 73096 | 12 | 180 | 100 | | |
| 73097 | 13 | 180 | 105 | | |
| 73098 | 14 | 190 | 130 | | |
| 73099 | 15 | 200 | 140 | | |
| 73100 | 16 | 205 | 150 | | |
| 73101 | 17 | 215 | 160 | | |
| 73102 | 18 | 225 | 210 | | |
| 73103 | 19 | 225 | 230 | | |
| 73105 | 21 | 245 | 280 | | |
| 73106 | 22 | 255 | 300 | | |
| 73107 | 23 | 260 | 320 | | |
| 73108 | 24 | 265 | 350 | | |
| 73109 | 26 | 298 | 565 | | |
| 73110 | 27 | 313 | 570 | | |
| 73111 | 28 | 313 | 580 | | |
| 73112 | 29 | 313 | 600 | | |
| 73113 | 30 | 328 | 630 | | |
| 73114 | 32 | 328 | 645 | | |
| 73115 | 36 | 328 | 650 | | |
| 73116 | 38 | 353 | 1118 | | |
| 73117 | 41 | 380 | 1150 | | |
| 73118 | 42 | 400 | 1170 | | |
| 73119 | 46 | 440 | 1200 | | |
| 73104 | 50 | 465 | 1300 | | |



1.000V
IEC 900 resp.
DIN EN 60 900

| COD |  |  |  |  |  |
|-------|---|---|---|---|---|
| 73347 | 1/4" | 140 | 50 | 10 | 1 |
| 73348 | 5/16" | 150 | 75 | | |
| 73349 | 3/8" | 160 | 85 | | |
| 73350 | 7/16" | 170 | 95 | | |
| 73351 | 1/2" | 180 | 125 | | |
| 73352 | 9/16" | 190 | 165 | | |
| 73353 | 5/8" | 205 | 190 | | |
| 73354 | 11/16" | 220 | 215 | | |
| 73355 | 3/4" | 225 | 250 | | |
| 73356 | 13/16" | 245 | 325 | | |
| 73357 | 7/8" | 255 | 340 | | |
| 73358 | 15/16" | 265 | 390 | | |
| 73359 | 1" | 270 | 450 | | |
| 73360 | 1.1/16" | 280 | 490 | | |
| 73361 | 1.1/8" | 290 | 530 | | |
| 73362 | 1.3/16" | 295 | 580 | | |
| 73363 | 1.1/4" | 305 | 585 | | |
| 73364 | 1.5/16" | 310 | 600 | | |





LLAVE DE ESTRELLA INCLINADA UNA BOCA / ANGLE RING WRENCH / CLE DEMI-LUNE / GEBOGEN RINGSCHLÜSSEL
CHIAVE A STELLA INCLINATA / STARTERSLEUTEL

| COD |  |  |  |  |  |
|-------|---|---|---|---|---|
| 73120 | 8 | 90 | 25 | 10 | 1 |
| 73121 | 9 | 100 | 30 | | |
| 73122 | 10 | 110 | 40 | | |
| 73123 | 11 | 115 | 50 | | |
| 73124 | 12 | 125 | 60 | | |
| 73125 | 13 | 135 | 80 | | |
| 73126 | 14 | 140 | 95 | | |
| 73127 | 15 | 145 | 110 | | |
| 73128 | 16 | 150 | 125 | | |
| 73129 | 17 | 160 | 135 | | |
| 73130 | 18 | 170 | 145 | | |
| 73131 | 19 | 175 | 175 | | |
| 73133 | 21 | 185 | 210 | | |
| 73134 | 22 | 195 | 240 | | |
| 73135 | 23 | 210 | 255 | | |
| 73136 | 24 | 230 | 275 | | |

1.000V
IEC 900 resp.
DIN EN 60 900







LLAVES DE PIPA ABIERTAS / ANGLED OPEN SOCKETS / CLES A PIPE DEBOUCHEES / PFEIFFENKOPFSCHLÜSSEL
CHIAVI A PIPA APERTE / GEBOGEN PIJPSLEUTEL / DE CACHIMBO ABERTAS

| COD |  |  |  |  |  |
|-------|--|--|--|--|--|
| 73203 | 8 | 108 | 45 | 5 | 1 |
| 73204 | 9 | 110 | 60 | | |
| 73205 | 10 | 127 | 85 | | |
| 73206 | 11 | 137 | 100 | | |
| 73207 | 12 | 147 | 128 | | |
| 73208 | 13 | 155 | 160 | | |
| 73209 | 14 | 166 | 185 | | |
| 73210 | 15 | 170 | 220 | | |
| 73211 | 16 | 174 | 230 | | |
| 73212 | 17 | 182 | 285 | | |
| 73213 | 18 | 188 | 330 | | |
| 73214 | 19 | 196 | 430 | | |
| 73215 | 20 | 213 | 460 | | |
| 73216 | 21 | 225 | 500 | | |
| 73217 | 22 | 245 | 630 | | |
| 73218 | 23 | 257 | 685 | 1 | 1 |
| 73219 | 24 | 267 | 735 | | |
| 73220 | 25 | 288 | 810 | | |
| 73221 | 26 | 293 | 1000 | | |
| 73222 | 27 | 304 | 1080 | | |
| 73223 | 28 | 317 | 1130 | | |
| 73224 | 29 | 328 | 1310 | | |
| 73225 | 30 | 350 | 1550 | | |
| 73226 | 32 | 350 | | | |

1.000V
IEC 900 resp.
DIN EN 60 900







LLAVE DE ESTRELLA DE CARRACA PLANA / RING RATCHET / POLYGONALE A CLIQUET / MAULKNARRE RINGSCHÜSSEL
CHIAVE A STELLA PIATTA CON CRICCO / RINGRATTELSLEUTEL

| COD |  |  |  |  |  |
|-------|---|---|---|---|---|
| 73145 | 10 | 135 | 45 | 6 | 1 |
| 73147 | 13 | 155 | 85 | | |
| 73150 | 17 | 175 | 150 | | |
| 73152 | 19 | 200 | 190 | | |

1.000V
IEC 900 resp.
DIN EN 60 900







LLAVE DE TUBO MANGO EN T / T HANDLE WRENCH / CLÉ POIGNÉ T / T-GRIFF SCHLÜSSEL
CHIAVE A TUBO CON IMPUGNATURA A T / T-GREEP SLEUTEL

| COD |  |  |  |  |  |
|-------|---|---|---|---|---|
| 73170 | 6 | 125 | 70 | 10 | 1 |
| 73171 | 7 | | 85 | | |
| 73172 | 8 | | 94 | | |
| 73173 | 9 | | 12 | | |
| 73174 | 10 | | 140 | | |
| 73175 | 11 | 135 | 176 | | |
| 73176 | 12 | | 186 | | |
| 73177 | 13 | | 220 | | |
| 73178 | 14 | | 260 | | |
| 73179 | 15 | | 275 | | |
| 73180 | 16 | | 292 | | |
| 73181 | 17 | | 300 | | |
| 73182 | 18 | | 330 | | |
| 73183 | 19 | | 362 | | |
| 73184 | 20 | 150 | 370 | | |
| 73185 | 21 | | 418 | | |
| 73186 | 22 | | 435 | | |
| 73187 | 23 | | 445 | | |
| 73188 | 24 | | 448 | | |







EN CRUZ / CROSS RIM WRENCH / CLE EN CROIX / KREUZSCHLÜSSEL / CHIAVE A CROCE / KRUISVELGSLEUTEL
CHAVE DE CRUZETA





| COD |  |  |  |  |
|-------|---|---|---|---|
| 73165 | 6-8-10-12 | 284 | 6 | 1 |
| 73166 | 7-9-11-13 | 286 | | |
| 73167 | 8-10-12-4 | 330 | | |



LLAVES HEXAGONALES / HEXAGONAL KEYS / CLES MALES / WINKELSCHRAUBENDREHER / CHIAVI ESAGONALI
INBUSSLEUTEL / CHAVES HEXAGONAIS

| COD |  |  |  |  |
|-------|---|---|---|---|
| 73155 | 3 | 16 | 10 | 1 |
| 73156 | 4 | 30 | | |
| 73157 | 5 | 42 | | |
| 73158 | 6 | 56 | | |
| 73159 | 8 | 100 | | |



| COD |  |  |  |  |
|-------|---|---|---|---|
| 73025 | 1/8" | 20 | 10 | 1 |
| 73026 | 3/16" | 30 | | |
| 73027 | 7/32" | 50 | | |

ARCO DE SIERRA / HACK SAW / MONTURE DE SCIE A METAUX / METALLSÄGEN GEBOGEN ARCHETTI / ZAAGBOGEN
ARCO DE SERRA

| COD |  |  |
|-------|---|---|
| 73030 | 820 | 1 |



23

1000V



IEC 900 resp.
DIN EN 60 900

3/8"





1.000V
IEC 900 resp.
DIN EN 60 900

MM

| COD |  |  |  |
|-------|---|---|---|
| 73261 | 8 | | |
| 73262 | 9 | 25 | |
| 73263 | 10 | | |
| 73264 | 11 | 30 | |
| 73265 | 12 | | |
| 73266 | 13 | 35 | |
| 73267 | 14 | | |
| 73268 | 15 | 40 | 10 |
| 73269 | 16 | | |
| 73270 | 17 | 45 | |
| 73271 | 18 | 55 | |
| 73272 | 19 | 60 | |
| 73273 | 20 | | |
| 73274 | 21 | 65 | |
| 73275 | 22 | 70 | |

INCH.

| COD |  |  |  |
|-------|---|---|---|
| 73478 | 5/16" | | |
| 73479 | 11/32" | 25 | |
| 73480 | 3/8" | | |
| 73481 | 7/16" | 30 | |
| 73482 | 1/2" | | |
| 73483 | 9/16" | 35 | |
| 73484 | 19/32" | 40 | 10 |
| 73485 | 5/8" | 50 | |
| 73486 | 11/16" | 55 | |
| 73487 | 3/4" | | |
| 73488 | 13/16" | 65 | |
| 73489 | 7/8" | 70 | |





LLAVE DE CARRACA REVERSIBLE / REVERSIBLE RATCHET HANDLE / CLE A CLIQUET / UMSCHALTKNARRE
CHIAVE A CRICCO REVERSIBLE / RATEL MET OMKEERMECHANISME / ROQUETE REVERSIVEL

| COD |  |  |  |  |  |
|-------|--|--|--|--|--|
| 73282 | 3/8" | 203 | 314 | 6 | 1 |



1.000V
IEC 900 resp.
DIN EN 60 900



ALARGADERA / EXTENSION / RALLONGE / VERLÄNGERUNG / PROLUNGA / VERLENGSTUK / EXTENÇÃO

| COD |  |  |  |  |
|-------|---|---|---|---|
| 73280 | 125 | 150 | | |
| 73281 | 250 | 290 | 5 | 1 |



1.000V
IEC 900 resp.
DIN EN 60 900

BOQUILLA HEXAGONAL / HEXAGONAL SOCKET / DOUILLE HEXAGONALE / HEXAGONALE EINSÄTZE / BUSSOLA ESAGONALE
HEXOGONALE DOP

| COD |  |  |  |
|-------|---|---|---|
| 73290 | 3 | 42 | |
| 73291 | 4 | 44 | |
| 73292 | 5 | 46 | |
| 73293 | 6 | 50 | 10 |
| 73294 | 7 | 64 | |
| 73295 | 8 | 66 | |
| 73296 | 10 | 78 | |



1.000V
IEC 900 resp.
DIN EN 60 900

MANGO EN T / T HANDLE / POIGNE T / T-GRIFF / IMPUGNATURA A T / T-GREEP

| COD |  |  |  |  |
|-------|---|---|---|---|
| 73283 | 185 | 292 | 5 | 1 |



1.000V
IEC 900 resp.
DIN EN 60 900





ADAPTADOR / ADAPTER / ADAPTATEUR / VERBINDUNGSTEILE / ADATTATORE / ADAPTOR / REDUTOR

| COD |  |  |  |  |
|-------|---|---|---|---|
| 73284 | 3/8"-1/2" | 47 | 5 | 1 |



1.000V
IEC 900 resp.
DIN EN 60 900

ADAPTADOR / ADAPTER / ADAPTATEUR / VERBINDUNGSTEILE / ADATTATORE / ADAPTOR / REDUTOR

| COD |  |  |  |  |
|-------|---|---|---|---|
| 73285 | 3/8"-1/4" | 63 | 5 | 1 |



1.000V
IEC 900 resp.
DIN EN 60 900

SET 3/8" 19 PCS.

| COD | C | mm | mm | mm | mm | Kg | |
|-------|---------------------------------|----|----|-------|----|----|------|
| 73015 | 6-7-8-9-10-11-12-13-14-17-19-21 | 10 | ● | 4,5,7 | ● | ● | 2,23 |

1.000V
IEC 900 resp.
DIN EN 60 900



1/2"

| MM | | | | INCH. | | | |
|-------|----|-----|----|-------|--------|-----|----|
| COD | mm | mm | mm | COD | INCH. | mm | mm |
| 73400 | 8 | 110 | | 73491 | 5/16" | 110 | |
| 73401 | 9 | | | 73492 | 3/8" | 120 | |
| 73402 | 10 | 130 | | 73493 | 7/16" | 135 | |
| 73403 | 11 | | | 73494 | 1/2" | 140 | |
| 73404 | 12 | 150 | | 73495 | 9/16" | 150 | |
| 73405 | 13 | | | 73496 | 19/32" | 155 | |
| 73406 | 14 | 155 | | 73497 | 5/8" | 155 | 10 |
| 73407 | 15 | | | 73498 | 21/32" | 160 | |
| 73408 | 16 | 165 | | 73499 | 11/16" | 165 | |
| 73409 | 17 | | 10 | 73500 | 3/4" | 180 | |
| 73410 | 18 | 185 | | 73501 | 13/16" | 200 | |
| 73411 | 19 | | | 73502 | 7/8" | 240 | |
| 73412 | 20 | 190 | | 73503 | 15/16" | 290 | |
| 73413 | 21 | 200 | | | | | |
| 73414 | 22 | 220 | | | | | |
| 73416 | 24 | 295 | | | | | |
| 73417 | 27 | 370 | | | | | |
| 73420 | 30 | 460 | | | | | |
| 73421 | 32 | 480 | | | | | |



1.000V
IEC 900 resp.
DIN EN 60 900

SERIE LARGA / LONG SERIE / SERIE LONGUE / LANGE FORM / SERIE LUNGA / SERIE LONGA

| MM | | | | INCH. | | | |
|-------|----|-----|----|-------|--------|-----|----|
| COD | mm | mm | mm | COD | INCH. | mm | mm |
| 73430 | 10 | | | 73378 | 3/8" | 65 | |
| 73431 | 11 | 65 | | 73379 | 7/16" | 70 | |
| 73432 | 12 | | | 73380 | 1/2" | 85 | |
| 73433 | 13 | | | 73381 | 9/16" | 95 | |
| 73434 | 14 | 70 | | 73382 | 5/8" | 105 | |
| 73435 | 15 | | | 73383 | 11/16" | 110 | 10 |
| 73436 | 16 | 80 | | 73384 | 3/4" | 120 | |
| 73437 | 17 | 85 | | 73385 | 13/16" | 130 | |
| 73438 | 18 | 90 | | 73386 | 7/8" | 135 | |
| 73439 | 19 | 100 | | 73387 | 15/16" | 135 | |
| 73440 | 21 | 120 | | | | | |
| 73441 | 22 | 130 | | | | | |
| 73442 | 23 | 135 | | | | | |
| 73443 | 24 | | | | | | |



1.000V
IEC 900 resp.
DIN EN 60 900

LLAVE DE CARRACA REVERSIBLE / REVERSIBLE RATCHET HANDLE / CLE A CLIQUET / UMSCHALTKNARRE
CHIAVE A CRICCO REVERSIBILE / RATEL MET OMKEERMECHANISME / ROQUETE REVERSIVEL

| COD | mm | mm | mm | mm | mm |
|-------|------|-----|-----|----|----|
| 73447 | 1/2" | 250 | 514 | 6 | 1 |

1.000V
IEC 900 resp.
DIN EN 60 900



ALARGADERA / EXTENSION / RALLONGE / VERLÄNGERUNG / PROLUNGA / VERLENGSTUK / EXTENÇÃO

| COD | mm | mm | mm | mm |
|-------|-----|-----|----|----|
| 73445 | 125 | 193 | 5 | 1 |
| 73446 | 250 | 358 | | |

1.000V
IEC 900 resp.
DIN EN 60 900





MANGO EN T / T HANDLE / POIGNE T / T-GRIFF / IMPUGNATURA A T / T-GREEP

| COD | mm | mm | mm | mm |
|-------|----|-----|----|----|
| 73448 | 1 | 665 | 5 | 1 |

1.000V
IEC 900 resp.
DIN EN 60 900





BOQUILLA HEXAGONAL / HEX BIT SOCKET / DOUILLE HEXAGONALE / HEXAGONALE EINSÄTZE / BUSSOLA ESAGONALE
HEXOGONALE DOP

| COD |  |  |  |
|-------|---|---|---|
| 73455 | 4 | 74 | |
| 73456 | 5 | 76 | |
| 73457 | 6 | | |
| 73458 | 7 | 80 | |
| 73459 | 8 | 86 | |
| 73460 | 9 | 90 | |
| 73461 | 10 | 96 | 10 |
| 73462 | 11 | | |
| 73463 | 12 | 135 | |
| 73464 | 13 | | |
| 73465 | 14 | | |
| 73468 | 17 | 158 | |





ADAPTADOR / ADAPTER / ADAPTATEUR / VERBINDUNGSTEILE / ADATTATORE / ADAPTOR / REDUTOR

| COD |  |  |  |  |
|-------|---|---|---|---|
| 73449 | 1/2"-3/8" | 82 | 5 | 1 |







SETS 1/2" 18 PCS.

| COD |  |  |  |  |  | Kg |
|-------|---|---|---|---|---|----|
| 73017 | 8-9-10-11-12-13-14-16-17-18-19-21-23 | 6-7 | | | 1/2"-3/8" | 2 |







SET 1/2" 32 PCS.

| COD |  |  |  |  |  | Kg |
|-------|---|---|---|---|---|------|
| 73016 | 8-9-10-11-12-13-14-15-16-17-18-19-20-21-22-23-24-25-26-27-28-29-30-32 | | 8-10-12-14-17 | | | 6,18 |



ALFOMBRAS AISLANTES / ISOLATING CARPETS / TAPIS ISOLANTS / ISOLIERTEPPISCH
TAPPETO ISOLATO / ISOLIERDEKEN / TAPETES ISOLANTES

| COD |  |  |  |  |
|-------|---|---|---|--|
| 73505 | | 0,6x0,6 | 1,4 | |
| 73506 | | 0,6x1 | 2,3 | |
| 73507 | | 0,6x5 | 4,7 | |
| 73508 | | 0,6x10 | 23,4 | |
| 73509 | | 1x1 | 3,9 | |
| 73510 | | 1x2 | 7,8 | |
| 73511 | 3 | 1x3 | 11,7 | |
| 73512 | | 1x5 | 18 | |
| 73513 | | 1x10 | 36 | |
| 73514 | | 1,2x1 | 4,7 | |
| 73515 | | 1,2x2 | 9,4 | |
| 73516 | | 1,2x5 | 23,4 | |
| 73517 | | 1,2x10 | 46,8 | |
| 73518 | | 0,6x1 | 3,12 | |
| 73519 | | 0,6x5 | 15,6 | |
| 73520 | | 0,6x10 | 31,2 | 1 |
| 73521 | 4 | 1x1 | 5,2 | |
| 73522 | | 1x5 | 26 | |
| 73523 | | 1x10 | 52 | |
| 73524 | | 1,2x10 | 62,4 | |
| 73525 | | 0,6x5 | 19,5 | |
| 73526 | | 0,6x10 | 39 | |
| 73527 | | 1x1 | 6,5 | |
| 73528 | 5 | 1x5 | 32,5 | |
| 73529 | | 1x10 | 65 | |
| 73530 | | 1,2x5 | 39 | |
| 73531 | | 1,2x10 | 78 | |
| 73532 | 10 | 1x5 | 65 | |
| 73533 | | 1x10 | 130 | |



DESTORNILLADORES / SCREWDRIVERS / TOURNEVIS / HANDSCHRAUBER CACCIAVITI / SCHROEVENDRAAIER / CHAVES DE FENDA

MASTERTORK



- SISTEMA DE PUNTA ANTIDESLIZANTE *NON-SLIP* Y MAGNETICA
- *NON-SLIP* ANTISLIPPERY MAGNETIC TIP
- *NON-SLIP* POINTE BRUNIE ANTIDÉRAPANTE ET MAGNETIQUE
- *NON-SLIP* ANTI-RUTSCH-SPITZE

- PUNTA ANTISCIVOLO *NON-SLIP*
- *NON-SLIP* ANTI SLIP TIP
- SISTEMA DE PUNTA ANTIDESLIZANTE DE CHAVE *NON-SLIP*

ELECTRICISTA / ELECTRICIAN / ELECTRICIEN / ELEKTRIKER / SCHROEVENDRAAIER VOOR SLEUFSCHROEVEN MODEL ELEKTRICIEN
PER ELETTRICISTI / ELETRICISTA

| COD | | | | | | |
|-------|-----|-----|-----|-----|-----|---|
| 66430 | 3 | 100 | 0,5 | 83 | 16 | 1 |
| 66431 | 4 | 125 | 0,8 | 105 | 8 | |
| 66432 | 5,5 | 150 | 1 | | 115 | |
| 66433 | 6,5 | | 1,2 | | | |
| 66434 | 8 | 175 | 1,6 | 128 | | |
| 66435 | 10 | 200 | | | | |



PHILIPS

| COD | | | | | | |
|-------|------|---|-----|-----|----|---|
| 66450 | PH-0 | 3 | 60 | 83 | 16 | 1 |
| 66451 | PH-1 | 5 | 100 | 105 | 8 | |
| 66452 | PH-2 | 6 | 125 | 115 | 6 | |
| 66453 | PH-3 | 7 | 150 | 128 | | |
| 66454 | PH-4 | 8 | 200 | | | |



POZIDRIV

| COD | | | | | | |
|-------|------|----|-----|-----|----|---|
| 66467 | PZ-0 | 3 | 60 | 83 | 16 | 1 |
| 66468 | PZ-1 | 5 | 100 | 105 | 8 | |
| 66469 | PZ-2 | 6 | 125 | 115 | 6 | |
| 66470 | PZ-3 | 8 | 150 | 128 | | |
| 66471 | PZ-4 | 10 | 200 | | | |



ROTORK

ELECTRICISTA / ELECTRICIAN / ELECTRICIEN / ELEKTRIKER / SCHROEVENDRAAIER VOOR SLEUFSCHROEVEN MODEL ELEKTRICIEN
PER ELETTRICISTI / ELETRICISTA

| COD | | | | | | |
|-------|-----|-----|---|-----|-----|---|
| 66893 | 100 | 0,5 | 3 | 100 | 16 | 1 |
| 66894 | 125 | 0,8 | 4 | | 105 | |
| 66895 | 150 | 1 | 5 | 110 | | |
| 66896 | | 1,2 | 6 | | | |



PHILIPS

| COD | | | | | | |
|-------|-----|------|---|-----|-----|---|
| 66903 | 60 | PH-0 | 3 | 100 | 16 | 1 |
| 66904 | 100 | PH-1 | 5 | 105 | 8 | |
| 66905 | 125 | PH-2 | 6 | | 110 | |
| 66906 | 150 | PH-3 | 8 | | | |



POZIDRIV

| COD | | | | | | |
|-------|-----|------|---|-----|-----|---|
| 66913 | 60 | PZ-0 | 3 | 100 | 16 | 1 |
| 66914 | 100 | PZ-1 | 5 | 105 | 8 | |
| 66915 | 125 | PZ-2 | 6 | | 110 | |
| 66916 | 150 | PZ-3 | 8 | | | |



EXPOSITORES Y SETS / DISPLAYS AND SETS / PRESENTOIRS ET SETS / STÄNDER / ESPOSITORE / DISPLAY STAND

MASTERTORK



A



B



C

NEW

1000V 4 PCS.
PCS.

| | | | |
|---|-------|------|---|
| 1 | 66467 | PZ-0 | + |
| 1 | 66468 | PZ-1 | + |
| 1 | 66469 | PZ-2 | + |
| 1 | 66470 | PZ-3 | + |

COD A: 69926

COD B: 69895

COD C: 68490

1000V 5 PCS.
PCS.

| | | | |
|---|-------|---------|---|
| 1 | 66430 | 3x100 | ⊥ |
| 1 | 66431 | 4x125 | ⊥ |
| 1 | 66432 | 5,5x150 | ⊥ |
| 1 | 66433 | 6,5x150 | ⊥ |
| 1 | 66434 | 8x175 | ⊥ |

COD A: 69928

COD B: 69897

COD C: 68492

1000V 6 PCS.
PCS.

| | | | |
|---|-------|---------|---|
| 1 | 66430 | 3x100 | ⊥ |
| 1 | 66431 | 4x125 | ⊥ |
| 1 | 66432 | 5,5x150 | ⊥ |
| 1 | 66433 | 6,5x150 | ⊥ |
| 1 | 66434 | 8x175 | ⊥ |
| 1 | 66435 | 10x200 | ⊥ |

COD A: 69925

COD B: 69894

COD C: 68493

1000V 8 PCS.
PCS.

| | | | |
|---|-------|---------|---|
| 1 | 66430 | 3x100 | ⊥ |
| 1 | 66431 | 4x125 | ⊥ |
| 1 | 66432 | 5,5x150 | ⊥ |
| 1 | 66433 | 6,5x150 | ⊥ |
| 1 | 66451 | PH-1 | + |
| 1 | 66452 | PH-2 | + |
| 1 | 66468 | PZ-1 | + |
| 1 | 66469 | PZ-2 | + |

COD A: 69932

COD B: 69931

COD C: 68494

1000V 4 PCS.
PCS.

| | | | |
|---|-------|------|---|
| 1 | 66450 | PH-0 | + |
| 1 | 66451 | PH-1 | + |
| 1 | 66452 | PH-2 | + |
| 1 | 66453 | PH-3 | + |

COD A: 69927

COD B: 69896

COD C: 68491

ROTORK



A



B



C

NEW

1000V 6 PCS.
PCS.

| | | | |
|---|-------|-------|---|
| 1 | 66893 | 3x100 | ⊥ |
| 1 | 66894 | 4x125 | ⊥ |
| 1 | 66895 | 5x150 | ⊥ |
| 1 | 66903 | PH-0 | + |
| 1 | 66904 | PH-1 | + |
| 1 | 66905 | PH-2 | + |

COD A: 69930

COD B: 69929

COD C: 68498

1000V 8 PCS.
PCS.

| | | | |
|---|-------|-------|---|
| 1 | 66893 | 3x100 | ⊥ |
| 1 | 66894 | 4x125 | ⊥ |
| 1 | 66895 | 5x150 | ⊥ |
| 1 | 66896 | 6x150 | ⊥ |
| 1 | 66904 | PH-1 | + |
| 1 | 66905 | PH-2 | + |
| 1 | 66914 | PZ-1 | + |
| 1 | 66915 | PZ-2 | + |

COD A: 69915

COD B: 66998

COD C: 68499

52 PCS. JUEGOS ELECTRICIDAD / ELECTRICIAN SETS / JEUX ÉLECTRICIENS /
WERKZEUGSÄTZE FÜR ELEKTRIZITÄT / KIT ELETTRICISTI / ELEKTRICIEN WERKTUIGSET /
JOGOS ÉCTRICIDADE



NEW



| COD | | pcs. | |
|-------|-------|------|----|
| 68994 | - | 52 | 6 |
| 68995 | 51011 | 53 | 31 |

| Pcs. | Descripción / Description | Composición / Composition |
|------|--|--|
| 8 | Alicates / pliers 1000V | 62373, 62378, 62380, 62379, 62381, 62382, 62383, 62389 |
| 1 | tenaza cortacables / cable cutter 1000V | 73008 |
| 2 | Pinzas / tweezers 1000V | 73040, 73041 |
| 2 | Cuchillos / knives 1000V | 73035, 73036 |
| 1 | Cortacables de carraca / ratchet electrician cable cutter 1000V | 73011 |
| 1 | tenazas de canal / box joint 1000V | 73005 |
| 1 | llave ajustable / adjustable wrench 1000V | 61986 |
| 8 | llaves fijas una boca / single ended open jaw spanner 1000V | 73064, 73065, 73066, 73067, 73068, 73071, 73073, 73076 |
| 1 | tijera electricista / electrician's scissors | 69534 |
| 1 | alicate para terminales / terminals plier | 62494 |
| 1 | tester | 66076 |
| 6 | destornilladores electricistas / electrician screwdriver 1000V | 66430, 66431, 66432, 66433, 66434, 66435 |
| 5 | destornilladores phillips screwdriver 1000V | 66450, 66451, 66452, 66453, 66454 |
| 1 | soldador de estaño / soldering iron | 63253 |
| 1 | succionador con boquilla antiestática para soldadura desoldering pump with anti-static rubber nozzle | 63256 |
| 1 | espejo articulado / joint telescopic mirror | 65587 |
| 6 | vasos / sockets 1000V | 73232, 73233, 73234, 73236, 73238, 73239 |
| 1 | alargadera / extension 1000V | 73245 |
| 1 | carraca / ratchet 1000V | 73246 |
| 3 | boquillas hexagonales / hexagonal sockets 1000V | 73251, 73252, 73253 |



37 PCS. JUEGOS ELECTRICIDAD / ELECTRICIAN SETS / JEUX ÉLECTRICIENS / WERKZEUGSÄTZE FÜR ELEKTRIZITÄT / KIT ELETTRICISTI / ELEKTRICIEN WERKTUIGSET JOGOS ÉCTRICIDADE



| COD | | pcs. | Hg. |
|-------|-------|------|-----|
| 68996 | - | 37 | 3 |
| 68997 | 51010 | 38 | 7 |

| Pcs. | Descripción / Description | Composición / Composition |
|------|--|--|
| 5 | Alicates / pliers 1000V | 62373, 62379, 62381, 62383, 62389 |
| 1 | tenaza cortacables / cable cutter 1000V | 73008 |
| 1 | Pinzas / tweezers 1000V | 73040 |
| 1 | Cuchillos / knives 1000V | 73035 |
| 1 | tenazas de canal / box joint 1000V | 73005 |
| 5 | llaves fijas una boca / single ended open jaw spanner 1000V | 73064, 73065, 73067, 73068, 73070 |
| 1 | tijera electricista / electrician's scissors | 69534 |
| 1 | tester | 66076 |
| 5 | destornilladores electricistas / electrician screwdriver 1000V | 66430, 66431, 66432, 66433, 66434 |
| 3 | destornilladores phillips screwdriver 1000V | 66451, 66452, 66453 |
| 1 | soldador de estaño / soldering iron | 63253 |
| 1 | succionador con boquilla antiestática para soldadura desoldering pump with anti-static rubber nozzle | 63256 |
| 6 | vasos / sockets 1000V | 73232, 73233, 73234, 73236, 73238, 73239 |
| 1 | alargadera / extension 1000V | 73245 |
| 1 | carraca / ratchet 1000V | 73246 |
| 3 | boquillas hexagonales / hexagonal sockets 1000V | 73251, 73252, 73253 |

16 PCS.



| COD | | pcs. | Hg. |
|-------|-------|------|-----|
| 68998 | - | 16 | 2 |
| 68999 | 51013 | 17 | 4 |

| Pcs. | Descripción / Description | Composición / Composition |
|------|--|----------------------------|
| 3 | Alicates / pliers 1000V | 62373, 62379, 62383 |
| 1 | Pinzas / tweezers 1000V | 73040 |
| 1 | Cuchillos / knives 1000V | 73035 |
| 3 | llaves fijas una boca / single ended open jaw spanner 1000V | 73064, 73067, 73070 |
| 1 | tijera electricista / electrician's scissors | 69534 |
| 1 | buscapolos / voltage tester | 66071 |
| 4 | destornilladores electricistas / electrician screwdriver 1000V | 66430, 66431, 66433, 66434 |
| 2 | destornilladores phillips screwdriver 1000V | 66451, 66452 |



Si no encuentra la medida o herramienta que necesita consúltenos
If you can not find the size or tool you require please consult with us
Si vous ne trouvez pas la dimension ou l'outils dont vous avez
besoin, consultez-nous

**ANTICHISPA / NON-SPARKING / ANTI-DEFLAGRANT / FUNKENFREI
ANTISCINTILLA / VONKVRIJE / ANTI-DEFLAGRANTE**

ANTICHISPA / NON-SPARKING / ANTI-DÉFLAGRANT

Las herramientas Antichispa EGA Master son la mejor alternativa para las aplicaciones en entornos de potencial explosivo. Todas las herramientas están forjadas después de la fundición para conseguir la mayor calidad en el mercado de la herramienta, siendo de atractivo acabado. Incorporamos a nuestras herramientas antichispa todo nuestro conocimiento de décadas diseñando y fabricando herramientas de mano, ergonómicas, fáciles de usar y con el diseño más atractivo.

EGA Master Non-Sparking Tools are the best alternative for non-sparking application purposes in potentially explosive environments. All tools are forged after casting to achieve the best quality in the market, both in mechanical properties and attractive finishing. We incorporate to our non-sparking tools all our knowledge of decades designing and manufacturing hand tools, making the most ergonomic and nicest design for them.

L'outillage anti-déflagrant EGA Master est la meilleure alternative pour l'application en milieux explosifs. Après coulage, tous les outils sont forgés pour obtenir la meilleure qualité du marché et une très bonne finition. Nous apportons notre longue expérience dans la conception et la fabrication d'outillage à main dans le domaine de l'ergonomie, de la facilité d'utilisation et du Design.

MATERIALES / MATERIALS / MATERIAUX

| Aleación Cobre-Berilio / Copper-Beryllium Alloy / Alliage Cuivre-Béryllium | | |
|--|----------------------------|-----------|
| Composición Composition Composition | Be | 1.8%-2% |
| | Ni+Co | 0.2%-1.2% |
| | otros / other / autres | <0.5% |
| | resto / rest / reste | Cu |
| Dureza / Hardness / Dureté | 35-40HRc (320-370 Brinell) | |
| Resistencia a la atracción / Tensile Strength Resistance à la traction | 1250 N/mm2 | |

| Aleación Aluminio-Bronce / Aluminium-Bronze Alloy / Alliage aluminium-bronze | | |
|--|----------------------------|---------|
| Composición Composition Composition | Al | 10%-12% |
| | Ni | 4%-6% |
| | Fe+Mn | <5.8% |
| | otros / other / autres | <0.5% |
| | resto / rest / reste | Cu |
| Dureza / Hardness / Dureté | 25-30HRc (250-291 Brinell) | |
| Resistencia a la tracción / Tensile Strength Resistance à la traction | 800 N/mm2 | |

NOTA IMPORTANTE / IMPORTANT NOTE / AVIS IMPORTANT

Por sus características especiales de dureza y resistencia (sensiblemente inferiores a los que se pueden obtener en herramientas de acero), las herramientas antichispa no pueden ser garantizadas contra ninguna deformación ni rotura. Sólo se repondrán en concepto de garantía aquellas herramientas antichispa cuya dureza HRC sea inferior (o exceda) a la indicada en nuestro catálogo: 35-40 HRC en el caso de las fabricadas en Cobre-Berilio y 25-30 HRC en las fabricadas en Aluminio Bronce.

The hardness and resistance that can be achieved with the materials used to manufacture non-sparking tools is significantly lower than that which can be obtained in tools made of steel. Due to these special characteristics of the material employed, non-sparking tools can not be guaranteed against any deformation or breakage. Non-sparking tools will be replaced under guarantee only when the hardness of the damaged tool does not reach (or exceeds) the one indicated in our catalogue: 35-40 HRC for those made in Copper-Beryllium and 25-30 HRC for those made in Aluminum Bronze.

Du fait de sa dureté et sa résistance spécifiques (sensiblement inférieures à celles d'outils en acier), les outils anti-déflagrants ne peuvent pas être garantis contre toute déformation ou rupture. Seulement seront pris en garantie, les outils anti-déflagrants dont la dureté soit inférieure (ou excède) à celle indiquée dans notre catalogue: 35-40 HRC pour le Cuivre - Béryllium et 25-30 HRC pour l'Aluminium - Bronze.



PROPIEDADES Y CARACTERÍSTICAS / PROPERTIES AND FEATURES / PROPIETES ET CARACTERISTIQUES

| PROPIEDAD / PROPERTY / PROPRIÉTÉ | APLICACIÓN O BENEFICIO / APPLICATION OR BENEFITS / APPLICATION OU BIENFAIT |
|---|---|
| Antichispa / Non-sparking Anti-déflagrant | Apropiado para entornos de potencial explosivo / Appropriate for explosive potential environments / Approprié pour un environnement explosif |
| Seguridad anti-magnética / non-magnetic safety / Sécurité anti-magnétique | Esencial para equipos que requieren una completa seguridad no magnética / Essential for equipments that require complete non-magnetic safety / Essentiel pour des équipements qui nécessitent une complète sécurité, sauf magnétique |
| Resistente a la corrosión / Corrosion resistant / Résistant à la corrosion | Especialmente concebidos para aplicaciones en entornos corrosivos como pueden ser en trabajos en la marina o de aplicaciones de bomberos / Specially well suited for applications in corrosive environments like encountered in marine works or fire-fighting applications / Spécialement conçu pour des environnements corrosifs, comme des travaux en air salin ou pratiqués par les pompiers |
| Forjado después de la fundición Forged after casting / Forgé après fonte | Proporcionan grandes propiedades mecánicas y gran acabado / Provides higher mechanical properties and better finishing / Cet outillage forgé a une grande résistance mécanique et une meilleure finition |
| Diseños Ergonómico / Ergonomic designs Formes ergonomiques | La utilización de dos materiales antideslizantes para los mangos, diseño totalmente ergonómico para hacer las operaciones más fácilmente, más rápido y confortable The use of bi-material anti-slippery handles, dipping anti-slippery handles, totally ergonomic designs make operations easier, more comfortable and master L'utilisation de deux matériaux anti-dérapants pour le manche, le design totalement ergonomique pour un travail plus aisé, plus rapide et confortable |

DIFERENCIAS Y ELECCIÓN DE LA OPCIÓN CORRECTA / DIFFERENCES AND HOW TO MAKE THE CORRECT CHOICE
DIFFÉRENCES ET SÉLECTION DE L'OPTION CORRECTE

| CONCEPTO / CONCEPT / CONCEPT | Cu-Be | Al-Bron |
|--|--|---|
| Dureza / Hardness / Dureté | 35-40HRc (320-370 Brinell) | 25-30HRc (250-291 Brinell) |
| Magnetismo Magnetism Magnetisme | La ausencia férrea en la composición, hace que sea más seguro cuando las aplicaciones no magnéticas son requeridas / Non ferrous substance in the composition makes it safer when non-magnetic applications are required L'absence de substance ferrique dans sa composition, fait de lui un alliage plus sûr pour des utilisations non magnétiques | Mínimo componente de hierro hacen que no sea 100% no magnético, aunque su bajo magnetismo lo hace apropiado para las aplicaciones de bajo magnetismo no críticas / Minimum ferrous component makes them not 100% non-magnetic, although its low magnetism make it appropriate for non critical non-magnetic applications Le minimum de substance ferreuse fait qu'il n'est pas à 100% amagnétique, malgré tout, son faible magnétisme le rend approprié pour des travaux amagnétiques mais non critiques |
| Durabilidad Durability Longévité | Muy grande debido a la gran dureza y la resistencia a tracción. Grandes esfuerzos pueden ser proporcionados / Much higher due to the higher hardness and tensile strength. Higher efforts can be made / Grande longévité due à sa composition et à la dureté. Supporte des forces importantes | No tanto como el Cu-Be Not as much as Cu-Be Pas autant que le Cu-Be |
| Precio Price Prix | Gran precio debido al material especial usado Higher price due to the special raw material used Onérosité due aux matériaux spéciaux utilisés | Sobre un 30% más bajo Around 30% lower price Approx. 30% moins cher |

PRECAUCIÓN: Estas herramientas no están clasificadas como antiestáticas debido a que son conductoras de electricidad. No usar herramientas que contengan más de un 65% de cobre en contacto directo con acetileno debido a la posible formación de acetilida explosiva especialmente en presencia de humedad.

CAUTION: These tools are not classified as anti-static because they do conduct electricity. Do not use high copper content tools (>65%) in direct contact with acetylene due to the possible formation of explosive acetylide, specially in the presence of moisture.

PRÉCAUTION: ces outils ne sont pas classifiés comme anti-statiques, car ils sont conducteurs d'électricité. Ne pas utiliser les outils composés de cuivre (>65%), en contact direct avec l'Acétylène car il y a un risque d'explosion acétylique surtout en présence d'humidité.

TABLA DE RIESGOS DE EXPLOSIÓN Y MÁXIMA TEMPERATURA / TABLE OF RISKS OF EXPLOSION AND MAXIMUM TEMPERATURE
 TABLEAU DE RISQUES D'EXPLOSION ET TEMPÉRATURE MAXIMALE

| Grupo de ignición Explosion group Groupe d'explosion | Clase de temperatura (máxima temperatura superficial admitida) Class of temperature (maximum surface temperature allowed) Classe de temperature maximum admise | | | | | |
|--|--|---|--|--|---|-------------|
| | T1 (450 °C) | T2 (300°C) | T3 (200 °C) | T4 (135 °C) | T5 (100 °C) | T6 (85 °C) |
| Temperatura de ignición Temperature of ignition Température d'ignition | 450 °C | 300 - 450 °C | 200 - 300 °C | 135 - 300 °C | 100 - 135 °C | 85 - 100 °C |
| I | Metano/ Methane Méthane | | | | | |
| IIA (Energía de ignición superior a Energy of ignition higher than Energie d'ignition supérieure à: 0,18 mJ) | Acetona/ Acetona Acétone | i-amil acetato i-amyl acetate i-Amylacétate | Amil alcohol Amyl alcohol Amylalcool | Acetaldeído Acetaldehyde Acetaldehyde | | |
| | Amoniaco/ Ammonia Ammoniac | n-butano n- butane n-Butane | Gasolinas Gasolines Gasolines | | | |
| | Benceno/ Benzene Benzéne | n-butano n- butane n-Butane | Gasoil Gas-oil Gas-Oil | | | |
| | Etilacetato Etilacetate Ethyl Acétate | 1-buteno 1-butene Butène | Combustible de calefacción/ Heating oil Huile de chauffage | | | |
| | | Acetato de etilo Ethyl acetate Propyl Acétate | n-hexano n-hexane n-Hexane | | | |
| | Metanol/ Methanol Méthanol | i-propanol i-propanol i-Propanol | | | | |
| | Propano/ Propane Propane | Vinilclorido Vinyl chloride Vinylchloride | | | | |
| | Tolueno/ Toluene Toluéne | | | | | |
| IIB (Energía de ignición entre Energy of ignition between Energie d'ignition de: 0.06 & 0.18 mJ) | Cianuro de hidrogeno Hydrogen cyanide Cyanure d'hydrogène | 1.3-butadieno 1.3-butadiene 1.3 Butadiéne | Dimetil eter Dimethyl ether Dimethyl ether | Dietileter Diethyl ether Diethyl ether | | |
| | | 1.4-dioxano 1.4-dioxane 1.4 Dioxane | Etilglicol Ethyl glycol Ethyl glycol | | | |
| | Gas de carbon Coal gas (lighting gas) Gaz de houille | Etileno Etylene Ethyléne | Hidrogeno de Sulfuro Hydrogen sulphide Sulfure d'hydrogène | | | |
| | Oxido de Etileno Ethylene oxide Oxyde d'Ethyléne | | | | | |
| IIC (Energía de ignición inferior a Energy of ignition less than Energie d'ignition inferieur á: 0,06 mJ) | Hidrogeno Hydrogen Hydrogène | Acetileno Acetylene Acétylène | | | Bisulfuro de Carbono/ bisulphideof carbon Bisulfure de Carbone | |
| | Gas de agua Gas of water Gaz d'eau (CO+H2) | | | | Nitrato de Etilo Ethyl nitrate Nitrate d'Ethyle | |

Las herramientas fabricadas en aleación cobre-berilio se pueden utilizar en todos los grupos (I, IIA, IIB y IIC) de manera segura, respetando siempre la temperatura máxima de superficie, excepto para el acetileno, porque el cobre reacciona con él creando gases de acetilina altamente explosivos.

Tools made of Cu-Be alloy can be used in all groups (I, IIA, IIB, IIC) in a safe way, always respecting the maximum surface temperature allowed, with the only exception of acetylene, with which copper might react and create highly explosive acetylene gases.

Le cuivre Béryllium peut être utilisé dans tous les cas d'une manière sûre, à condition que la température superficielle de l'outil ne dépasse pas le niveau de température pour chaque gaz. Ne pas utiliser en présence d'Acétylène, car le contact peut créer des étincelles explosives.

Las herramientas fabricadas en aleación Aluminio-Bronce se pueden utilizar en todos los grupos excepto en IIC (hidrogeno, gas de agua, acetileno, bisulfuro de carbono y nitrato de etilo), respetando siempre la temperatura máxima de superficie.

Tools made of Al-Bronze alloy can be used in a safe way, always respecting the maximum surface temperature allowed, except for the IIC group (Hydrogen, gas of water, acetylene, bisulphide of carbon, Ethyl nitrate).

L'aluminium-Bronze est sûr pour tous ces produits sauf pour le groupe IIC (gaz d'eau, Hydrogène, Acétylène, Bisulfure de carbone et Nitrate d'éthyle, encore que de tous ces gaz seul l'hydrogène est común), à condition que la température superficielle de l'outil ne dépasse pas le niveau de température pour chaque gaz.

HERRAMIENTAS DE COBRE O LATÓN/ COPPER OR BRASS TOOLS / OUTILS EN CUIVRE OU EN LAITON

Las herramientas de cobre o latón son seguras en ambientes explosivos de los grupos de riesgo I y IIA. En estos ambientes pueden ser empleados con total seguridad.

EGA Master tiene disponible una gama completa de martillos y mazas de cobre y latón a disposición de los clientes.

Es conveniente saber que las herramientas de cobre o latón no pueden ser nunca considerados como sustitutos de las herramientas de aluminio-bronce o cobre-berilio, debido a que su dureza es muy inferior a la necesaria para la mayoría de aplicaciones. Existe la tentación de escoger herramientas en cobre o latón debido a su menor coste respecto a las aleaciones de aluminio-bronce o cobre-berilio. Esta opción no solo es peligrosa de por sí, sino que hará que al corto-medio plazo tengamos que reemplazarlas por nuevas unidades debido al desgaste sufrido por sus bajas durezas.

Por tanto, las herramientas de cobre o latón deberían ser empleadas únicamente en aquellas aplicaciones que se deban llevar a cabo en zonas de riesgo de explosión (I y IIA), si la misma aplicación requiriese emplear herramientas de cobre o latón en un ambiente sin riesgo de explosión. Si usted emplearía una herramienta de acero en una zona sin riesgo de explosión, entonces debe escoger por su seguridad y rentabilidad herramientas fabricadas en aluminio-bronce o cobre-berilio para realizar la misma labor en una zona de riesgo, nunca una herramienta de cobre o latón.

Copper or brass tools are safe in explosive environments of risk groups I and IIA. It is safe to work with them in these environments.

EGA Master has available a complete range of copper and brass hammers and mallets made in both materials.

It is convenient to know that copper or brass tools can never be considered as alternatives to aluminum-bronze or copper-beryllium alloy tools, because their hardness is too low for most applications. There is the temptation to choose copper or brass tools due to their lower cost compared to aluminum-bronze or copper-beryllium ones. This choice is not only risky in itself, but in the short/mid term it will be necessary to replace them for new ones for the wearing out suffered due to their low hardness.

For this reason, copper or brass tools should only be used in those jobs that have to be made in risky environments (I and IIA), if the same job would be made with copper or brass tools in a non-risky environment. In case you would use a steel tool in a non-risky environment, than you should choose for your safety and profitability tools made in aluminum-bronze or copper-beryllium alloys to make the same job in a risky environment, never a copper or brass tool.

Les outils en cuivre ou en laiton sont sûrs pour des atmosphères explosives de groupes de risques I et IIA. Ils peuvent être utilisés en toute sécurité dans ces atmosphères.

EgaMaster a toute une gamme complète de marteaux et de masses en cuivre et en laiton au service des clients.

Il est important de savoir que les outils en cuivre ou en laiton ne peuvent jamais être considérés comme substitutifs des outils en aluminium-bronze ou en cuivre-béryllium, ceci du à une dureté bien inférieure à celle nécessaire pour la plus part des applications. La tentation de substituer l'Al-Br et le Cu-Bé par le cuivre ou le laiton existe, dû au coût plus bas. Cette option, non seulement est dangereuse, mais aussi peu rentable, car l'outillage en cuivre ou en laiton sera à remplacer à très court terme, car beaucoup moins résistant.

Mais les outils en cuivre ou en laiton devraient être uniquement utilisés pour des applications en zones de risques d'explosions (I et IIA), si le même usage était requis en atmosphère sans risque d'explosion.

Pour un emploi d'outils en acier en atmosphère sans risque d'explosion, alors pour votre sécurité et une meilleure rentabilité, vous devez prendre des outils fabriqués en Aluminium - Bronze ou en Cuivre- Béryllium pour des applications en zone de risque, jamais un outil en cuivre ou en laiton.



ALEACION ACETILEX, TRABAJO SEGURO INCLUSO EN AMBIENTES DE ACETILENO
ACETILEX ALLOY, SAFE WORK EVEN IN ACETYLENE ENVIRONMENTS
ALLIAGE ACETILEX, TRAVAIL SÛR MÊME EN PRÉSENCE D'ACÉTHYLÈNE

Los ambientes de acetileno hacen que no se puedan emplear elementos con composiciones de cobre superiores al 65%. Ambas aleaciones aluminio-bronce y cobre-berilio tienen porcentajes de cobre superiores al 65%. La razón no estriba en que una chispa de cobre berilio tenga la suficiente energía como para provocar la ignición del acetileno, sino que el cobre puede reaccionar con el acetileno creando acetilidas altamente explosivas de por sí.

Por este motivo, se desaconseja el uso de cualquiera de las aleaciones de cobre berilio o aluminio bronce en ambientes de acetileno.

En Ega Master S.A., siempre buscando soluciones innovadoras que aporten mayor seguridad, hemos desarrollado la aleación ACETILEX, 100% segura en ambientes de acetileno. Una vez más, pioneros en seguridad.

Items with copper compositions higher than 65% should not be used in acetylene environments. Both aluminum bronze and copper-beryllium alloys do have higher copper compositions than 65%. The reason is not that copper beryllium can create a spark with enough energy to create the ignition of acetylene, but that copper can react with acetylene creating highly explosive acetylides.

For this reason, copper-beryllium or aluminum-bronze alloys should not be used in acetylene environments.

In Ega Master S.A., always committed to find new innovative solutions that will increase safety, we have developed the ACETILEX alloy, 100% safe to be used in acetylene environments. Once again, pioneers in safety.

Les atmosphères en présence d'acétylène font qu'on ne peut utiliser de compositions en cuivre supérieurs à 65%. Les deux alliages aluminium - bronze et cuivre - béryllium ont un pourcentage de cuivre supérieur à 65%. La raison ne repose pas sur le fait que l'étincelle du cuivre-béryllium ait l'énergie suffisante pour provoquer l'ignition de l'acétylène, mais que le cuivre peut avoir une réaction avec l'acétylène, ce qui peut provoquer des particules hautement explosives. Pour cette raison, il est déconseillé l'utilisation d'alliages de cuivre béryllium ou d'aluminium bronze en présence d'acétylène.

En permanence à la recherche de solutions novatrices ayant la meilleure sécurité, Ega Master S.A. a développé l'alliage ACETILEX, 100% sûre en présence d'acétylène. Une fois de plus, pionniers en sécurité.

PRINCIPALES CAMPOS DE APLICACIÓN / MAIN APPLICATION FIELDS / PRINCIPALES DOMAINES D'APPLICATION

| | | |
|--|---|---|
| Petroquímicas / Petrochemicals / Petrochimie | Industria Pirotécnica / Fireworks Industry Industrie pyrotechnique | Minas / Mines / Mines |
| Refinerías / Refineries / Raffineries | Industria química / Chemical Industry Industrie chimique | Defensa / Defence / Defense |
| Industria del Petróleo / Oil Companies Sociétés pétrolières | Industria papelera / Paper making Industries Industrie du papier | Fuerzas aéreas / Air Forces / Forces aériennes |
| Conductos de tubo de Gas y Petróleo Gas & oil pipe lines Conduits de gaz et de pétrole | Silos de harina y molinos / Flour silos and mills Silos et moulins | Marina / Navy / Marine |
| Estaciones de servicio y energía Power Stations Stations de service et energie | Fábrica cervecera / Breweries / Brasseries | Fabricación de munición y armas Weapon & ammunition fabrication Fabrication de poudres et explosifs |
| Fabricación de pintura Paint Manufacturing Fabrication de peinture | Industrias de procesamiento de Alcohol Alcohol processing industries Fabrication d'alcool | Industria aeroespacial / Aerospace industry Industrie aérospaciale |
| Fabricación de plástico Plastic manufacturing Fabrication de plastique | Destilerías / Distilleries / Distilleries | Industria del automóvil / Automobile Industry Industrie automobile |
| Industria Farmacéutica / Pharmaceutical Industry Industrie pharmaceutique | Bomberos / Fire-fighters / Pompiers | Etc. |

INSTRUCCIONES DE USO Y GARANTÍA / INSTRUCTIONS FOR USE & WARRANTY / INSTRUCTIONS D'UTILISATION ET GARANTIE

1 Las herramientas antichispa no pueden alcanzar la dureza de las herramientas convencionales. Por esta razón en su uso se debe tener un especial cuidado, sin sobreesfuerzos ni alta temperatura. / Non-Sparking Tools cannot reach the hardness of conventional tools. For this reason the use of Non-Sparking Tools has to be carried out with special care, avoiding over-training, heating, etc / L'outillage anti-déflagrant ne peut avoir la même dureté que l'outillage traditionnel. Pour cela, il requière une attention spéciale, en évitant la surcharge, la chaleur...

2 El uso de herramientas antichispa no debe ser la única medida preventiva en áreas en las que se ha diseñado para ello. Otros objetos, como ropa o material presencial deben también ser adecuadas para aplicaciones Antichispa. / The use of Non-Sparking Tools must not be the only preventive measure in areas which the items are designed for. Other items, clothes or present material must also be adequate for non-sparking purposes. / L'utilisation d'outillage anti-déflagrant ne doit pas être le Seul moyen de prévention dans les environnements pour lequel il est conçu. D'autres objets, comme les vêtements et matériels présents doivent aussi être adaptés aux applications anti-déflagrantes.

CERTIFICADO DE CONFORMIDAD

Certificamos que las herramientas fabricadas en Cobre Berilio poseen propiedades anti-chispa, anti-magnéticas y anti-corrosión.

Dureza
35-40HRC (320-370 Brinell)
Resistencia a la Tracción
1250 N/mm²
Temperatura de Fusión
857°C -982°C
Porcentaje Composición Química
Be: 1,8%-2%
Ni+Co: 0,2%-1,2%
Otros: <0,5%
Cu Resto

Certificamos que las herramientas fabricadas en aleación Aluminio - Bronce poseen propiedades antichispa.

Dureza
25-30HRC (250-291 Brinell)
Resistencia a la Tracción
800 N/mm²
Porcentaje Composición Química
Al: 10%-12%
Ni: 4%-6%
Fe+Mn: <5,8%
Otros max: <0,5%
Cu Resto

CERTIFICATE OF COMPLIANCE

We hereby certify that, the tools made from Beryllium Copper alloy provide non sparking, non magnetic and non corrosive properties.

Hardness
35-40HRC (320-370 Brinell)
Tensile Strength-Break
1250 N/mm²
Melting Range Temperature
857°C -982°C
Chemical Composition Percentage
Be: 1,8%-2%
Ni+Co: 0,2%-1,2%
Other max: <0,5%
Cu Balance

We hereby certify that, the tools made from Aluminium Bronze alloy provide non sparking properties

Hardness
25-30HRC (250-291 Brinell)
Tensile Strength-Break
800 N/mm²
Chemical Composition Percentage
Al: 10%-12%
Ni: 4%-6%
Fe+Mn: <5,8%
Other max: <0,5%
Cu Balance

Ega Master S.A.
Aner Garmendia
Managing Director



ALICATES / PLIERS / PINCES / ZANGEN / PINZE / UITVOERING / ALICTAES

UNIVERSALES / COMBINATION / UNIVERSELLES / KOMBIZANGEN / UNIVERSALE / COMBINATIETANG / UNIVERSAIS

| COD | | | |
|-------|---------|-----|-----|
| Cu-Be | Al-Bron | | |
| 70100 | 70530 | 160 | 250 |
| 70101 | 70531 | 180 | 320 |
| 70102 | 70532 | 200 | 375 |



BOCA PLANA / FLAT NOSE / PLATES / FLACHZANGEN / BECCHI PIATTI / PLATE TANG / PONTAS CHATAS

| COD | | | |
|-------|---------|-----|-----|
| Cu-Be | Al-Bron | | |
| 70103 | 70533 | 160 | 170 |

 BOCA REDONDA / ROUND NOSE / RONDES / RUNDZANGEN / BECCHI TONDI / TANG MET GEBOGEN BEKKEN
PONTAS REDONDAS

| COD | | | |
|-------|---------|-----|-----|
| Cu-Be | Al-Bron | | |
| 70104 | 70534 | 160 | 160 |



TELEFONISTA / LONG NOSE / TELEPHONE / TELEFONZANGEN / TELEFONISTI / TELEFOONTANG / TELEFONISTA

| COD | | | |
|-------|---------|-----|-----|
| Cu-Be | Al-Bron | | |
| 70105 | 70535 | 160 | 250 |
| 70106 | 70536 | 200 | 375 |

 CORTE DIAGONAL / DIAGONAL CUTTING PLIERS / COUPANTES DIAGONALES / KRAFTSEITENSCHNEIDER
TAGLIO LATERALE / ZIKNIPTANG / CORTE DIAGONAL

| COD | | | |
|-------|---------|-----|-----|
| Cu-Be | Al-Bron | | |
| 70107 | 70537 | 160 | 250 |

 CORTE DIAGONAL REFORZADO / HEAVY DUTY CUTTING NIPPERS / COUPANTES RENFORCEES / KRAFTSEITENSCHNEIDER
TAGLIO LATERALE RINFORZATO / ZIKNIPTANG-VERSTERKT / CORTE DIAGONAL REFORÇADO

| COD | | | |
|-------|---------|-----|-----|
| Cu-Be | Al-Bron | | |
| 72094 | 72095 | 160 | 260 |
| 70108 | 70538 | 180 | 320 |

 ALICATE GASISTA / GAS PIPE PLIERS / PINZE GAZIER / ROHRZANGE / PINZA PER GASISTA / BUISTANG
ALICATE PARA TUBO DE GAZ

| COD | | | |
|-------|---------|-----|-----|
| Cu-Be | Al-Bron | | |
| 70109 | 70539 | 210 | 375 |



ALICATE TIPO FORD / SLIP JOINT PLIER / PINCE BIPRISE / MECHANIKERZANGE / PINZE PER GASISTI / TANG DUBBLE INSTELLING
ALICATE MOTORISTA

| Cu-Be | COD | Al-Bron | L | W |
|-------|-----|---------|----|-----|
| 70114 | | 70544 | 8" | 250 |



PELACABLES / WIRESTRIPPER / PINCES A DENUDER / ABISOLIERZANGEN / PINZE SPELAFILI / STRIPTANG / DECAPADORES

| Cu-Be | COD | Al-Bron | L | W |
|-------|-----|---------|-----|-----|
| 73903 | | 73904 | 170 | 220 |



TENAZAS / PLIERS / ZANGE / TENAILLES / TENAGLIE / NIPTANG / ALICATES

PICO DE LORO / WASSERPUMPENZANGE / GROOVE JOINT / MULTIPRISE A CREMAILLERE / PINZE REGOLABILI
WATERPOMPTANG MET RILLENVERSTELLING / BICO DE PAPAGAIO

| Cu-Be | COD | Al-Bron | L | W |
|-------|-----|---------|-----|-----|
| 70110 | | 70540 | 10" | 340 |
| 70111 | | 70541 | 12" | 700 |



TENAZA DE CANAL / BOX JOINT / MULTIPRISE ENTREPASSEE / WASSERPUMPENZANGE / PINZE REGOLABILI
WATERPOMPTANG / BICO DE PAPAGAIO

| Cu-Be | COD | Al-Bron | L | W |
|-------|-----|---------|-----|-----|
| 73897 | | 73898 | 10" | 350 |



| Cu-Be | COD | Al-Bron | L | W |
|-------|-----|---------|-----|-----|
| 72300 | | 72302 | 10" | 340 |



TENAZA DE CARPINTERO / CARPENTER PINCER / TENAILLE DE MANUISIER / KANTENZANGE / TENAGLIE PER CARPENTIERI
KLEMTANG / TURQUES DE CARPINTERO

| Cu-Be | COD | Al-Bron | L | W |
|-------|-----|---------|----|-----|
| 70112 | | 70542 | 7" | 310 |
| 70113 | | 70543 | 8" | 380 |





ALICATE PARA TERMINALES / CRIMPING PLIER / PINCE POUR TERMINAUX / CRIMPZANGE / PINZE PER TERMINALI / KRIMPTANG
ALICATE PARA TERMINAIS

| Cu-Be | COD | Al-Bron | L | W |
|-------|-----|---------|----|-----|
| 73900 | | 73901 | 8" | 220 |



**LLAVE AJUSTABLE / ADJUSTABLE WRENCH / CLE A MOLETTE / ROLLGABELSCHLÜSSEL /
CHIAVI REGOLABILI A RULLINO / VERSTELBARE SLEUTEL / CHAVE AJUSTAVEL**

| COD | |  |  |  |
|-------|---------|---|---|---|
| Cu-Be | Al-Bron | | | |
| 71448 | 71451 | 6" | 20 | 160 |
| 70117 | 71452 | 8" | 25 | 335 |
| 70118 | 71453 | 10" | 30 | 570 |
| 70119 | 71454 | 12" | 35 | 865 |
| 70120 | 71455 | 15" | 48 | 1250 |
| 71449 | 71456 | 18" | 56 | 2000 |
| 71450 | 71457 | 24" | 65 | 3100 |



**EXTRACTORES / GEAR PULLERS / EXTRACTEURS / ABZIEHERS / TREKKERS / ESTRATTORI /
EXTRACTORES**
**EXTRACTOR 3 GARRAS ARTICULADAS REVERSIBLES / 3 JAW REVERSIBLE GEAR PULLER / EXTRACTEUR 3 BRAS ARTICULES
REVERSIBLES / AUSSENABZIEHER 3 KLAUEN / ESTRATTORE A 3 BRACCI REVERSIBILI / BUITENTREKKER 3 BEKKEN /**

| COD | | L min - max |  |
|-------|---------|----------------|---|
| Cu-Be | Al-Bron | | |
| 72470 | 72471 | 50-100 | 3000 |
| 72472 | 72473 | 60-150 | 3800 |
| 72474 | 72475 | 70-200 | 5600 |
| 72476 | 72477 | 80-350 | 11500 |

**PINZAS / TWEEZERS / BRUCELLES / GREIFPINZETTEN / PINZETTE DI PRECISIONES /
PINCETTEN / PINÇAS**
BOCA FINA / NEAT TIPS / BECS FINS / FEINE BACKEN / A PUNTA FINE / FIJNE BEKKEN / PONTAS FINAS

| COD | |  |  |
|-------|---------|---|---|
| Cu-Be | Al-Bron | | |
| 70115 | 70547 | 155 | 40 |

BOCA PLANA / FLAT NOSE / PLATES / FLACH ZANGE / PUNTA PIATTA / PLATTE BEKKEN / PONTAS PLANAS

| COD | |  |  |
|-------|---------|---|---|
| Cu-Be | Al-Bron | | |
| 70116 | 70548 | 100 | 30 |



EGGA *Master* S.A.
ART IN INNOVATION

LLAVES / WRENCHES / CLES / SCHLÜSSEL / CHIAVI / SLEUTELS / CHAVES

LLAVES FIJAS / OPEN-END WRENCHES / CLES PLATES / GABELSCHLÜSSEL / CHIAVI FISSE / STEEKSLEUTELS
CHAVES DUAS BOCAS



mm

| Cu-Be | Al-Bron | mm | L (mm) | mm |
|-------|---------|-------|--------|------|
| 70135 | 70549 | 6-7 | 95 | 40 |
| 70136 | 70550 | 6-8 | | |
| 70137 | 70551 | 7-9 | 97 | 55 |
| 70138 | 70552 | 8-9 | 98 | 60 |
| 70139 | 70553 | 8-10 | 100 | 65 |
| 70140 | 70554 | 9-10 | 105 | 70 |
| 70141 | 70555 | 9-11 | 110 | 75 |
| 70142 | 70556 | 10-11 | 115 | 85 |
| 70143 | 70557 | 10-12 | 120 | 95 |
| 70144 | 70558 | 10-14 | 124 | 115 |
| 70145 | 70559 | 11-14 | 125 | 125 |
| 70146 | 70560 | 12-13 | 127 | 135 |
| 70147 | 70561 | 12-14 | 130 | 145 |
| 73648 | 73649 | 13-15 | 136 | 165 |
| 70148 | 70562 | 14-15 | 143 | |
| 70149 | 70563 | 14-17 | 150 | 180 |
| 70150 | 70564 | 16-17 | 157 | 200 |
| 70151 | 70565 | 16-18 | 163 | 215 |
| 70152 | 70566 | 17-19 | 170 | 235 |
| 70153 | 70567 | 17-22 | 176 | 270 |
| 70154 | 70568 | 18-19 | 179 | 285 |
| 70155 | 70569 | 19-22 | 185 | 330 |
| 70156 | 70570 | 19-24 | 188 | 360 |
| 70157 | 70571 | 20-22 | 195 | 390 |
| 70158 | 70572 | 21-23 | 200 | 410 |
| 70159 | 70573 | 22-24 | 210 | 445 |
| 70160 | 70574 | 22-27 | 215 | 470 |
| 70161 | 70575 | 24-26 | 225 | 515 |
| 70162 | 70576 | 24-27 | 230 | 535 |
| 72923 | 72922 | 24-30 | 233 | 565 |
| 70163 | 70577 | 25-28 | 236 | |
| 70164 | 70578 | 27-29 | 246 | 630 |
| 72925 | 72924 | 27-32 | 255 | 700 |
| 70165 | 70579 | 30-32 | 265 | 775 |
| 72927 | 72926 | 30-36 | 265 | 900 |
| 70166 | 70580 | 32-36 | 265 | 1155 |
| 70167 | 70581 | 34-36 | 305 | 1475 |
| 73337 | 73336 | 36-41 | 335 | 1500 |
| 70168 | 70582 | 41-46 | 355 | 1790 |
| 72921 | 72919 | 46-50 | 370 | 2100 |
| 70169 | 70583 | 50-62 | 400 | 3285 |
| 70588 | 70584 | 55-60 | 415 | 3270 |
| 70589 | 70585 | 60-65 | 435 | 4540 |
| 70590 | 70586 | 65-70 | 460 | 7580 |
| 70591 | 70587 | 70-80 | 520 | 9190 |

inch.

| Cu-Be | Al-Bron | inch | L (mm) | mm |
|-------|---------|-----------------|--------|-----|
| 70592 | 70637 | 7/32"-1/4" | 90 | 35 |
| 70593 | 70638 | 1/4"-9/32" | | |
| 70594 | 70639 | 1/4"-5/16" | 100 | 45 |
| 70595 | 70640 | 5/16"-3/8" | | |
| 70596 | 70641 | 3/8"-7/16" | 110 | 60 |
| 70597 | 70642 | 7/16"-1/2" | 120 | 85 |
| 70598 | 70643 | 1/2"-9/16" | 130 | 90 |
| 70599 | 70644 | 1/2"-5/8" | 150 | 100 |
| 70600 | 70645 | 1/2"-11/16" | | 110 |
| 70601 | 70646 | 9/16"-5/8" | 165 | 120 |
| 70602 | 70647 | 9/16"-3/4" | | 130 |
| 70603 | 70648 | 19/32"-11/16" | 180 | 140 |
| 70604 | 70649 | 19/32"-25/32" | | 150 |
| 70605 | 70650 | 5/8"-3/4" | 185 | 160 |
| 70606 | 70651 | 11/16"-25/32" | | 170 |
| 70607 | 70652 | 11/16"-7/8" | 190 | 180 |
| 70608 | 70653 | 3/4"-13/16" | | 200 |
| 70609 | 70654 | 3/4"-7/8" | 210 | 220 |
| 70610 | 70655 | 25/32"-13/16" | | 185 |
| 70611 | 70656 | 25/32"-7/8" | 230 | 230 |
| 70612 | 70657 | 13/16"-7/8" | | 190 |
| 70613 | 70658 | 7/8"-15/16" | 240 | 305 |
| 70614 | 70659 | 7/8"-31/32" | | 210 |
| 70615 | 70660 | 7/8"-1" | 255 | 320 |
| 70616 | 70661 | 15/16"-1" | | 220 |
| 70617 | 70662 | 7/8"-1.1/16" | 260 | 340 |
| 70618 | 70663 | 15/16"-1.1/16" | | 230 |
| 70619 | 70664 | 1"-1.1/8" | 270 | 365 |
| 70620 | 70665 | 1.1/16"-1.1/8" | | 235 |
| 70621 | 70666 | 1.1/16"-1.1/4" | 280 | 380 |
| 70622 | 70667 | 1.1/8"-1.5/16" | | 240 |
| 70623 | 70668 | 1.1/16"-1.7/16" | 290 | 410 |
| 70624 | 70669 | 1.1/8"-1.1/2" | | 255 |
| 70625 | 70670 | 1.1/4"-1.3/8" | 300 | 430 |
| 70626 | 70671 | 1.1/4"-1.7/16" | | 260 |
| 70627 | 70672 | 1.5/16"-1.1/2" | 310 | 450 |
| 70628 | 70673 | 1.3/8"-1.1/2" | | 270 |
| 70629 | 70674 | 1.7/16"-1.5/8" | 320 | 470 |
| 70630 | 70675 | 1.1/2"-1.11/16" | | 280 |
| 70631 | 70676 | 1.5/8"-1.13/16" | 330 | 490 |
| 70632 | 70677 | 1.3/4"-1.5/8" | | 290 |
| 70633 | 70678 | 1.11/16"-1.7/8" | 340 | 510 |
| 70634 | 70679 | 1.13/16"-2" | | 300 |
| 70635 | 70680 | 2.1/16"-2.5/16" | 350 | 530 |
| 70636 | 70681 | 2.1/4"-2.3/8" | | 310 |



Cu-Be cobre berilio / beryllium copper / cuivre beryllium / Kupfer Beryllium / koper beryllium / rame-berillio

Al-Bron aluminio bronce / aluminium bronze / alliage aluminium-bronze / Aluminium Bronze / aluminium brons / aluminio bronzo



LLAVES / WRENCHES / CLES / SCHLÜSSEL / CHIAVI / SLEUTELS / CHAVES

 LLAVES COMBINADAS / COMBINATION WRENCHES / CLES MIXTES / GABEL RINGSCHLÜSSEL / CHIAVI COMBinate
RINGSTEEKSLEUTELS / CHAVES BOCA E LUNETE

mm

| Cu-Be | COD | Al-Bron |  |  |  |
|-------|-----|---------|---|---|---|
| 70170 | | 70682 | 6 | 115 | 35 |
| 70171 | | 70683 | 7 | 120 | 40 |
| 70172 | | 70684 | 8 | 125 | 45 |
| 70173 | | 70685 | 9 | 130 | 60 |
| 70174 | | 70686 | 10 | 135 | 65 |
| 70175 | | 70687 | 11 | 140 | 70 |
| 70176 | | 70688 | 12 | 145 | 85 |
| 70177 | | 70689 | 13 | 155 | 95 |
| 70178 | | 70690 | 14 | 165 | 100 |
| 70179 | | 70691 | 15 | 175 | 110 |
| 70180 | | 70692 | 16 | 185 | 150 |
| 70181 | | 70693 | 17 | 195 | 160 |
| 70182 | | 70694 | 18 | 205 | 190 |
| 70183 | | 70695 | 19 | 215 | 210 |
| 70184 | | 70696 | 20 | 225 | 240 |
| 70185 | | 70697 | 21 | 235 | 260 |
| 70186 | | 70698 | 22 | 245 | 280 |
| 70187 | | 70699 | 23 | 255 | 350 |
| 70188 | | 70700 | 24 | 265 | 380 |
| 70189 | | 70701 | 25 | 270 | 400 |
| 70190 | | 70702 | 26 | 275 | 420 |
| 70191 | | 70703 | 27 | 285 | 485 |
| 70192 | | 70704 | 28 | 293 | 525 |
| 70193 | | 70705 | 29 | 300 | 630 |
| 70194 | | 70706 | 30 | 310 | 670 |
| 70195 | | 70707 | 31 | 320 | 730 |
| 70196 | | 70708 | 32 | 330 | 770 |
| 72700 | | 71786 | 33 | 335 | 800 |
| 72701 | | 71787 | 34 | 337 | 850 |
| 70197 | | 70709 | 35 | 337 | 930 |
| 70198 | | 70710 | 36 | 345 | 940 |
| 70199 | | 70711 | 38 | 353 | 1090 |
| 70200 | | 70712 | 40 | 355 | 1100 |
| 70201 | | 70713 | 41 | 366 | 1125 |
| 70202 | | 70714 | 42 | 366 | 1220 |
| 70203 | | 70715 | 46 | 405 | 1550 |
| 70204 | | 70716 | 50 | 420 | 1735 |
| 70205 | | 70717 | 55 | 435 | 2210 |
| 70206 | | 70718 | 60 | 462 | 2585 |
| 70207 | | 70719 | 65 | 470 | 2980 |
| 70208 | | 70720 | 70 | 480 | 3560 |
| 70209 | | 70721 | 75 | 490 | 4100 |
| 70210 | | 70722 | 80 | 500 | 4550 |
| 70211 | | 70723 | 85 | 515 | 5350 |
| 70212 | | 70724 | 90 | 525 | 5800 |

inch.

| Cu-Be | COD | Al-Bron |  |  |  |
|-------|-----|---------|---|---|---|
| 70725 | | 70751 | 1/4" | 115 | 25 |
| 70726 | | 70752 | 5/16" | 123 | 30 |
| 70727 | | 70753 | 11/32" | 128 | 35 |
| 70728 | | 70754 | 3/8" | 128 | 40 |
| 70729 | | 70755 | 7/16" | 135 | 55 |
| 70730 | | 70756 | 1/2" | 140 | 70 |
| 70731 | | 70757 | 9/16" | 163 | 80 |
| 70732 | | 70758 | 5/8" | 177 | 130 |
| 70733 | | 70759 | 11/16" | 195 | 140 |
| 70734 | | 70760 | 3/4" | 215 | 200 |
| 70735 | | 70761 | 13/16" | 230 | 205 |
| 70736 | | 70762 | 7/8" | 235 | 280 |
| 70737 | | 70763 | 15/16" | 256 | 330 |
| 70738 | | 70764 | 1" | 266 | 360 |
| 70739 | | 70765 | 1.1/16" | 283 | 460 |
| 70740 | | 70766 | 1.1/8" | 297 | 500 |
| 70741 | | 70767 | 1.1/4" | 324 | 680 |
| 70742 | | 70768 | 1.5/16" | 350 | 1000 |
| 70743 | | 70769 | 1.3/8" | 355 | 1150 |
| 70744 | | 70770 | 1.7/16" | 360 | 1200 |
| 70745 | | 70771 | 1.1/2" | 360 | 1350 |
| 70746 | | 70772 | 1.5/8" | 365 | 1480 |
| 70747 | | 70773 | 1.11/16" | 374 | 1500 |
| 70748 | | 70774 | 1.13/16" | 405 | 1620 |
| 70749 | | 70775 | 1.7/8" | 405 | 1700 |
| 70750 | | 70776 | 2" | 420 | 1700 |

KIT DEMO 6 LLAVES / 6 SPANNER DEMO KIT / KIT DÉMO. 6 CLÉS / DEMOKIT 6 SCHLÜSSEL / KIT 6 CHIAVI DI DIMOSTRAZIONE / DEMOKIT 6 SLEUTELS / KIT DEMO 6 CHAVES

| COD | Composicion/Composition | | | |
|-------|-------------------------|----------------------|-----|-----|
| 69342 | 61727 | Cr-V Aeroespacial | 8mm | 300 |
| | 61627 | Cr-V Espejo - Mirror | | |
| | 73062 | Cr-V 1000V | | |
| | 70172 | Cu-Be | | |
| | 70684 | Al-Bron | | |
| | 71669 | Titanium | | |



LLAVES ACODADAS / DOUBLE OFFSET RING WRENCHES / CLES POLYGAONALES / RINGSCHLÜSSEL / CHIAVI POLIGONALI
RINGSLEUTELS / CHAVES LUNETA



| mm | Cu-Be | COD | Al-Bron | | | |
|----|-------|-----|---------|-------|-----|------|
| | 70213 | | 70777 | 6-7 | 115 | 25 |
| | 70214 | | 70778 | 7-9 | 130 | 50 |
| | 70215 | | 70779 | 8-9 | | 55 |
| | 70216 | | 70780 | 8-10 | 135 | 60 |
| | 70217 | | 70781 | 9-10 | | 70 |
| | 70218 | | 70782 | 9-11 | 140 | 80 |
| | 70219 | | 70783 | 10-11 | | 100 |
| | 70220 | | 70784 | 10-14 | 160 | 120 |
| | 70221 | | 70785 | 11-14 | | 150 |
| | 70222 | | 70786 | 12-13 | 180 | 200 |
| | 70223 | | 70787 | 12-14 | | 200 |
| | 70224 | | 70788 | 13-14 | 200 | 205 |
| | 70225 | | 70789 | 13-15 | | 210 |
| | 72133 | | 72137 | 14-16 | 220 | 225 |
| | 72134 | | 72138 | 14-17 | | 290 |
| | 70227 | | 70791 | 16-17 | 250 | 295 |
| | 70228 | | 70792 | 16-18 | | 310 |
| | 70229 | | 70793 | 17-19 | 280 | 355 |
| | 70230 | | 70794 | 17-22 | | 370 |
| | 70231 | | 70795 | 18-19 | 285 | 405 |
| | 70232 | | 70796 | 19-22 | | 455 |
| | 70233 | | 70797 | 19-24 | 310 | 470 |
| | 70234 | | 70798 | 20-22 | | 500 |
| | 70235 | | 70799 | 21-23 | 340 | 520 |
| | 70236 | | 70800 | 22-24 | | 550 |
| | 70237 | | 70801 | 22-27 | 350 | 580 |
| | 72822 | | 72823 | 24-26 | | 670 |
| | 73339 | | 73338 | 24-27 | 360 | 705 |
| | 70238 | | 70802 | 24-30 | | 740 |
| | 70239 | | 70803 | 25-28 | 380 | 805 |
| | 70240 | | 70804 | 27-29 | | 850 |
| | 70241 | | 70805 | 27-30 | 395 | 1050 |
| | 70242 | | 70806 | 27-32 | | 1100 |
| | 70243 | | 70807 | 30-32 | 404 | 1145 |
| | 72956 | | 72912 | 31-33 | | 1165 |
| | 70244 | | 70808 | 30-36 | 410 | 1530 |
| | 72957 | | 72913 | 32-35 | | 1600 |
| | 72135 | | 72139 | 32-36 | 470 | 2075 |
| | 72136 | | 72140 | 34-36 | | 2200 |
| | 70245 | | 70809 | 36-38 | 490 | 2500 |
| | 70246 | | 70810 | 36-41 | | 476 |
| | 70247 | | 70811 | 41-46 | | |
| | 72251 | | 72250 | 46-50 | | |
| | 72253 | | 72252 | 55-60 | | |

| inch. | Cu-Be | COD | Al-Bron | | | |
|-------|-------|-----|---------|----------------|-----|------|
| | 70812 | | 70841 | 7/32-1/4" | 120 | 30 |
| | 70813 | | 70842 | 5/16-3/8" | 125 | 45 |
| | 70814 | | 70843 | 3/8-7/16" | 140 | 60 |
| | 70815 | | 70844 | 7/16"-1/2" | 155 | 90 |
| | 70816 | | 70845 | 1/2-9/16" | 174 | 115 |
| | 70817 | | 70846 | 9/16-5/8" | 215 | 190 |
| | 70818 | | 70847 | 5/8-3/4" | 240 | 230 |
| | 70819 | | 70848 | 11/16"-25/32" | 255 | 240 |
| | 70820 | | 70849 | 3/4"-13/16" | | 295 |
| | 70821 | | 70850 | 13/16-7/8" | 275 | 350 |
| | 70822 | | 70851 | 7/8-15/16" | 305 | 405 |
| | 70823 | | 70852 | 7/8-31/32" | 310 | 420 |
| | 70824 | | 70853 | 7/8-1" | | 440 |
| | 70825 | | 70854 | 7/8-1.1/16" | 317 | 480 |
| | 70826 | | 70855 | 15/16-1" | 310 | 490 |
| | 70827 | | 70856 | 15/16-1.1/16" | 340 | 500 |
| | 70828 | | 70857 | 1-1.1/16" | 330 | 575 |
| | 70829 | | 70858 | 1-1.1/8" | 346 | 550 |
| | 70830 | | 70859 | 1.1/16-1.1/8" | 330 | 570 |
| | 70831 | | 70860 | 1.1/16-1.1/4" | 367 | 620 |
| | 70832 | | 70861 | 1.1/8-1.5/16" | 373 | 680 |
| | 70833 | | 70862 | 1.1/4-1.5/16" | 380 | 1020 |
| | 70834 | | 70863 | 1.1/4"-1.7/16" | 410 | 1080 |
| | 70835 | | 70864 | 1.7/16-1.5/8" | 450 | 1585 |
| | 70836 | | 70865 | 1.5/8-1.13/16" | 470 | 2070 |
| | 70837 | | 70866 | 1.13/16-2" | 490 | 2530 |
| | 70838 | | 70867 | 2.1/16-2.3/8" | 510 | 2800 |
| | 70839 | | 70868 | 2-2.3/8" | 520 | 3000 |
| | 70840 | | 70869 | 2.1/4-2.3/8" | 530 | 3500 |

Cu-Be cobre berilio / beryllium copper / cuivre beryllium / Kupfer Beryllium / koper beryllium / rame-berillio

Al-Bron aluminio bronce / aluminium bronze / alliage aluminium-bronze / Aluminium Bronze / aluminium brons / aluminio bronzo



LLAVE ESTRELLA PLANA / DOUBLE ENDED FLAT RING SPANNER / POLYGONALE A DROITE / DOPPELRINGSCHLÜSSEL
POLIGONALE DIRITTA / RINSLEUTEL, PLAT / LUNETTA DIREITA





| mm | | COD |  |  |  |
|-------|---------|-----|---|--|---|
| Cu-Be | Al-Bron | | | | |
| 73960 | 73961 | | 7-9 | 115 | 40 |
| 73962 | 73963 | | 10-11 | 140 | 60 |
| 73964 | 73965 | | 12-14 | 160 | 100 |
| 73966 | 73967 | | 14-17 | 180 | 110 |
| 73968 | 73969 | | 16-18 | 200 | 180 |
| 73970 | 73971 | | 18-19 | 225 | 260 |
| 73972 | 73973 | | 17-22 | 235 | 280 |
| 73974 | 73975 | | 19-21 | 240 | 300 |
| 73976 | 73977 | | 20-22 | 250 | 350 |
| 73978 | 73979 | | 21-23 | 255 | 390 |
| 73980 | 73981 | | 22-24 | 280 | 430 |
| 73982 | 73983 | | 24-27 | 300 | 550 |
| 73984 | 73985 | | 25-28 | 305 | 580 |
| 73986 | 73987 | | 27-30 | 310 | 680 |
| 73988 | 73989 | | 27-32 | 320 | 720 |
| 73990 | 73991 | | 30-32 | 340 | 750 |

LLAVE DE CARRACA PARA RACORES / RATCHET SPANNER / CLE A TUYATEUR A CLIQUET / KNARRENRHORSCHLÜSSEL
OPEN RATELSLEUTEL / CHIAVEN A CRICCO PER RACCORDI / CHAVE RAPIDA ABERTA COM ROQUETE



| mm | | COD |  |  |  |
|-------|---------|-----|---|---|---|
| Cu-Be | Al-Bron | | | | |
| 70870 | 70887 | | 9 | 150 | 160 |
| 70871 | 70888 | | 11 | | 180 |
| 70872 | 70889 | | 13 | 155 | 190 |
| 70873 | 70890 | | 14 | | 200 |
| 70874 | 70891 | | 17 | 200 | 200 |
| 70875 | 70892 | | 19 | | 220 |
| 70876 | 70893 | | 22 | 220 | 210 |
| 70877 | 70894 | | 24 | | 210 |
| 70878 | 70895 | | 27 | 245 | 210 |
| 70879 | 70896 | | 30 | | 230 |
| 70880 | 70897 | | 32 | 280 | 230 |
| 70881 | 70898 | | 36 | | 260 |
| 70882 | 70899 | | 41 | 295 | 260 |
| 70883 | 70900 | | 46 | | 450 |
| 70884 | 70901 | | 50 | 360 | 530 |
| 70885 | 70902 | | 55 | | 670 |
| 70886 | 70903 | | 60 | 440 | 840 |

| inch. | | COD |  |  |  |
|-------|---------|-----|---|---|---|
| Cu-Be | Al-Bron | | | | |
| 70904 | 70920 | | 3/8" | 150 | 160 |
| 70905 | 70921 | | 1/2" | | 190 |
| 70906 | 70922 | | 9/16" | 155 | 190 |
| 70907 | 70923 | | 11/16" | | 200 |
| 70908 | 70924 | | 3/4" | 200 | 220 |
| 70909 | 70925 | | 7/8" | | 220 |
| 70910 | 70926 | | 1" | 220 | 210 |
| 70911 | 70927 | | 1.1/16" | | 245 |
| 70912 | 70928 | | 1.3/16" | 280 | 230 |
| 70913 | 70929 | | 1.1/4" | | 260 |
| 70914 | 70930 | | 1.7/16" | 295 | 260 |
| 70915 | 70931 | | 1.5/8" | | 450 |
| 70916 | 70932 | | 1.13/16" | 360 | 530 |
| 70917 | 70933 | | 2" | | 670 |
| 70918 | 70934 | | 2.3/16" | 440 | 840 |
| 70919 | 70935 | | 2.3/8" | | 840 |

LLAVES / WRENCHES / CLES / SCHLÜSSEL / CHIAVI / SLEUTELS / CHAVES

LLAVE DE CONSTRUCCION / CONSTRUCTION WRENCH WITH PIN / CLE DE CONSTRUCTION A POINTE
MONTEUR-ROHRSTECKSCHLÜSSEL / PIJPSLEUTEL MONTEUR / CHIAVE PER COSTRUZIONE / CHAVE DE CONSTRUÇÃO



| mm | | COD | | | |
|-------|---------|-----|----|-----|------|
| Cu-Be | Al-Bron | | | | |
| 70248 | 71732 | | 22 | 270 | 500 |
| 70249 | 71733 | | 24 | 290 | |
| 70250 | 71734 | | 27 | 320 | 700 |
| 70251 | 71735 | | 30 | 350 | |
| 70252 | 71736 | | 32 | 370 | 800 |
| 70253 | 71737 | | 36 | 390 | |
| 70254 | 71738 | | 38 | 400 | 1000 |
| 70255 | 71739 | | 41 | 410 | |
| 70256 | 71740 | | 44 | 420 | 1100 |
| 70257 | 71741 | | 46 | | |
| 70258 | 71742 | | 50 | 430 | 1300 |

LLAVE DE CONSTRUCCION FIJA ACODADA / CONSTRUCTION OPEN WRENCH WITH PIN / CLE A FOURCHE CONTRE COUDEE
MAULSCHLÜSSEL MIT STIFT / CHIAVE DI COSTRUZIONE FISSA / STEEKSLEUTEL MET PIN / CHAVE DE CONSTRUÇÃO FIXA



| mm | | COD | | | |
|-------|---------|-----|----|-----|------|
| Cu-Be | Al-Bron | | | | |
| 73940 | 73941 | | 32 | 400 | 850 |
| 73942 | 73943 | | 36 | 430 | 1200 |
| 73944 | 73945 | | 41 | 470 | 1900 |
| 73946 | 73947 | | 46 | 500 | 2800 |
| 73948 | 73949 | | 50 | 530 | 3700 |

LLAVE PARA RACORES / FLARE NUT / POLYGONALE A TUYATEUR/ OFFENER DOPPELRINGSCHÜSSEL / CHIAVE PER RACCORDI
RINGSLEUTEL MET KRAAG / LUNETAS ABERTAS COM BATENTE





| mm | | COD | | |
|-------|---------|-----|------------|-----|
| Cu-Be | Al-Bron | | | |
| 72723 | 72724 | | 3/8"-7/16" | 50 |
| 72725 | 72726 | | 7/16"-1/2" | 100 |
| 72727 | 72728 | | 1/2"-9/16" | 150 |
| 72729 | 72730 | | 9/16"-5/8" | 250 |
| 72731 | 72732 | | 5/8"-3/4" | 300 |
| 72733 | 72734 | | 3/4"-7/8" | 350 |
| 72735 | 72736 | | 7/8"-1" | 400 |
| 72737 | 72738 | | 1"-1.1/8" | 500 |

LLAVES / WRENCHES / CLES / SCHLÜSSEL / CHIAVI / SLEUTELS / CHAVES

 FIJA DE GOLPE / SLOGGING OPEN WRENCH / A FOURCHE A FRAPPER / SCHLAG MAULSCHLÜSSEL / FISSE AD IMPULSO
 STEEKSLAGSLEUTEL / BOCA DE IMPACTO

mm

| Cu-Be | COD | Al-Bron |  |  |  |
|-------|-----|---------|---|---|---|
| 70280 | | 71013 | 14 | 120 | 0,2 |
| 70281 | | 71014 | 17 | 125 | 0,3 |
| 70282 | | 71015 | 19 | | |
| 70283 | | 71016 | 22 | 135 | 0,4 |
| 70284 | | 71017 | 24 | 150 | |
| 70285 | | 71018 | 27 | 165 | 0,7 |
| 70286 | | 71019 | 30 | 180 | |
| 70287 | | 71020 | 32 | 190 | 0,9 |
| 70288 | | 71021 | 36 | 210 | |
| 70289 | | 71022 | 41 | 230 | 1,6 |
| 70290 | | 71023 | 46 | 240 | |
| 70291 | | 71024 | 50 | 255 | 2,1 |
| 70292 | | 71025 | 55 | 272 | 2,6 |
| 70293 | | 71026 | 60 | 290 | 3,6 |
| 70294 | | 71027 | 65 | 307 | 4,5 |
| 70295 | | 71028 | 70 | 325 | 5,5 |
| 70296 | | 71029 | 75 | 343 | 6,8 |
| 71007 | | 71030 | 80 | 360 | 7,7 |
| 71008 | | 71031 | 85 | 380 | 8,6 |
| 71009 | | 71032 | 90 | 400 | 9,8 |
| 71010 | | 71033 | 95 | | 10,5 |
| 71011 | | 71034 | 100 | 430 | 12 |
| 71012 | | 71035 | 105 | 440 | 12,2 |

inch.

| Cu-Be | COD | Al-Bron |  |  |  |
|-------|-----|---------|---|---|---|
| 71036 | | 71055 | 9/16" | 110 | 0,2 |
| 72105 | | 72113 | 5/8" | | 0,3 |
| 71037 | | 71056 | 11/16" | 125 | |
| 71038 | | 71057 | 3/4" | 135 | 0,6 |
| 71039 | | 71058 | 7/8" | 150 | |
| 71040 | | 71059 | 15/16" | 165 | 1,6 |
| 72106 | | 72114 | 1" | 180 | |
| 71041 | | 71060 | 1.1/16" | 190 | 2,1 |
| 72107 | | 72115 | 1.1/8" | 210 | |
| 71042 | | 71061 | 1.1/4" | 230 | 3 |
| 72108 | | 72116 | 1.3/8" | 240 | |
| 71043 | | 71062 | 1.7/16" | 255 | 4,3 |
| 72109 | | 72117 | 1.1/2" | 272 | |
| 71044 | | 71063 | 1.5/8" | 290 | 6,8 |
| 71045 | | 71064 | 1.13/16" | 307 | |
| 72110 | | 72118 | 1.7/8" | 343 | 9,8 |
| 71046 | | 71065 | 2" | 360 | |
| 71047 | | 71066 | 2.3/16" | 377 | 13 |
| 72111 | | 72119 | 2.1/4" | 400 | |
| 71048 | | 71067 | 2.3/8" | 430 | 12 |
| 72112 | | 72120 | 2.1/2" | 465 | |
| 71049 | | 71068 | 2.9/16" | 343 | 6,8 |
| 71050 | | 71069 | 3" | 360 | |
| 71051 | | 71070 | 3.1/8" | 400 | 9,8 |
| 71052 | | 71071 | 3.9/16" | 430 | |
| 71053 | | 71072 | 4" | 465 | 13 |
| 71054 | | 71073 | 4.5/16" | 343 | |

EGGA *Master* S.A.
ART IN INNOVATION

LLAVES / WRENCHES / CLES / SCHLÜSSEL / CHIAVI / SLEUTELS / CHAVES

ESTRELLA DE GOLPE / SLOGGING RING / POLYGONALE A FRAPPER / SCHLAG RINGSCHLÜSSEL / POLIGONALE AD IMPULSO
RINGSLAGSLEUTEL / LUNETA DE IMPACTO



| mm | | | | | inch. | | | | | |
|-------|-----|---------|---------|-----|-------|-------|---------|----------|----------|--------|
| Cu-Be | COD | Al-Bron | L mm | Kg | Cu-Be | COD | Al-Bron | L mm | Kg | |
| 70297 | | 71080 | 17 | 125 | 72121 | | 72127 | 5/8" | 130 | |
| 70298 | | 71081 | 19 | | 71108 | | 71133 | 11/16" | 165 | 0,3 |
| 70299 | | 71082 | 22 | 140 | 71109 | | 71134 | 3/4" | | 0,4 |
| 70300 | | 71083 | 24 | | 71110 | | 71135 | 7/8" | 175 | |
| 71906 | | 72951 | 26 | 145 | 71111 | | 71136 | 1" | | 185 |
| 70301 | | 71084 | 27 | 150 | 71112 | | 71137 | 1.1/16" | 205 | |
| 70302 | | 71085 | 30 | 165 | 72122 | | 72128 | 1.1/8" | | 225 |
| 70303 | | 71086 | 32 | 180 | 71113 | | 71138 | 1.3/16" | 235 | |
| 73326 | | 73331 | 34 | 200 | 71114 | | 71139 | 1.1/4" | | 250 |
| 70304 | | 71087 | 36 | | 0,6 | 72123 | | 72129 | 1.3/8" | |
| 71834 | | 71835 | 38 | 230 | 71115 | | 71140 | 1.13/32" | 274 | 1,4 |
| 73327 | | 73332 | 40 | | 0,7 | 71116 | | 71141 | | |
| 70305 | | 71088 | 41 | 240 | 72301 | | 71791 | 1.7/16" | 320 | 2,3 |
| 73328 | | 73333 | 42 | | 245 | 72124 | | 72130 | | |
| 73329 | | 73334 | 44 | 250 | | 71117 | | 71142 | 1.13/16" | 350 |
| 70306 | | 71089 | 46 | | 0,8 | 72125 | | 72131 | 1.3/4" | |
| 72229 | | 72228 | 47 | 260 | 71118 | | 71143 | 2" | 390 | 4,5 |
| 73330 | | 73335 | 48 | | 265 | 71119 | | 71144 | | |
| 70307 | | 71090 | 50 | 1,3 | | 71120 | | 71145 | 2.5/16" | 390 |
| 70308 | | 71091 | 52 | 270 | 71121 | | 71146 | 2.3/8" | 390 | |
| 70309 | | 71092 | 55 | | 1,4 | 71122 | | 71147 | | 2.1/2" |
| 73470 | | 73394 | 56 | 280 | 71123 | | 71148 | 2.9/16" | 390 | 4,9 |
| 73471 | | 73395 | 58 | | 1,4 | 71124 | | 71149 | | |
| 70310 | | 71093 | 60 | 280 | 71125 | | 71150 | 2.3/4" | 390 | 4,9 |
| 70311 | | 71094 | 65 | 295 | 71126 | | 71151 | 2.15/16" | | |
| 70312 | | 71095 | 70 | 310 | 71127 | | 71152 | 3" | 390 | 4,9 |
| 70313 | | 71096 | 75 | 325 | 71128 | | 71153 | 3.1/16" | | |
| 70314 | | 71097 | 80 | 340 | 71129 | | 71154 | 3.1/8" | 390 | 4,9 |
| 70315 | | 71098 | 85 | 355 | 71130 | | 71155 | 3.3/8" | | |
| 70316 | | 71099 | 90 | 390 | 71131 | | 71156 | 3.9/16" | 390 | 4,9 |
| 70317 | | 71100 | 95 | 3,4 | 71132 | | 71157 | 3.3/4" | | |
| 70318 | | 71101 | 100 | 3,6 | | | | | | |
| 71074 | | 71102 | 105 | 3,9 | | | | | | |
| 71075 | | 71103 | 110 | 4,2 | | | | | | |
| 71076 | | 71104 | 115 | 4,3 | | | | | | |
| 71077 | | 71105 | 120 | 4,5 | | | | | | |
| 71078 | | 71106 | 125 | 4,6 | | | | | | |
| 71079 | | 71107 | 130 | 4,9 | | | | | | |
| 72084 | | 72089 | 135 | 5,2 | | | | | | |
| 72085 | | 72090 | 140 | 5,5 | | | | | | |
| 72086 | | 72091 | 145 | 5,9 | | | | | | |
| 72087 | | 72092 | 150 | 6,3 | | | | | | |
| 72088 | | 72093 | 155 | 6,7 | | | | | | |

LLAVE DINAMOMETRICA / TORQUE WRENCH / CLE DYNAMOMETRIQUE / DREHMOMENTSCHLÜSSEL / CHIAVE DINAMOMETRICA
CHAVE DINAMOMETRICA

| Cu-Be | COD | Al-Bron | L mm | Nm | Kg |
|-------|-----|---------|---------|-----|------|
| 72171 | | 72174 | 3/8" | 100 | 600 |
| 72172 | | 72175 | 1/2" | 300 | 1250 |
| 72173 | | 72176 | 3/4" | 500 | 1700 |





LLAVES / WRENCHES / CLES / SCHLÜSSEL / CHIAVI / SLEUTELS / CHAVES



ESTRELLA DE GOLPE ACODADA / OFFSET SLOGGING RING WRENCH / CLE POLYGONALE A FRAPPER CONTRE COUDEE
SCHLAG-RINGSCHLÜSSEL, GEKRÖPFT / POLIGONALE AD IMPULSO A GOMITO / RINGSLAGSLEUTEL DIEP GEBOGEN
CHAVE LUNETA INCLINADA DE PANCADA



mm



| Cu-Be | COD | Al-Bron |  |  |  |
|-------|-----|---------|---|---|---|
| 74122 | | 74123 | 27 | 245 | 650 |
| 74124 | | 74125 | 30 | 270 | 900 |
| 74126 | | 74127 | 32 | | |
| 74128 | | 74129 | 36 | 280 | 1000 |
| 74130 | | 74131 | 41 | 305 | 1300 |
| 74132 | | 74133 | 46 | 310 | 1700 |
| 74134 | | 74135 | 50 | 320 | 2000 |
| 73593 | | 73594 | 55 | | |
| 73595 | | 73596 | 60 | 355 | 2700 |
| 73597 | | 73598 | 65 | 380 | 3200 |
| 73599 | | 73600 | 70 | 400 | 3800 |
| 73601 | | 73602 | 75 | 420 | 4200 |
| 73603 | | 73604 | 80 | 435 | 5200 |
| 73605 | | 73606 | 85 | 440 | 6200 |
| 73607 | | 73608 | 90 | | |
| 73609 | | 73610 | 95 | | |
| 73611 | | 73612 | 100 | | |
| 73613 | | 73614 | 110 | | |
| 73615 | | 73616 | 120 | | 8000 |

inch.

| Cu-Be | COD | Al-Bron |  |  |  |
|-------|-----|---------|---|---|---|
| 73653 | | 73654 | 1.1/16" | 245 | 650 |
| 73655 | | 73656 | 1.1/4" | 270 | 900 |
| 73657 | | 73658 | 1.7/16" | 270 | |
| 73659 | | 73660 | 1.1/2" | 280 | 1000 |
| 73661 | | 73662 | 1.5/8" | 305 | 1300 |
| 73663 | | 73664 | 1.3/4" | 310 | 1700 |
| 73665 | | 73666 | 1.7/8" | | |
| 73667 | | 73668 | 2" | 320 | 2000 |
| 73669 | | 73670 | 2.1/4" | | |
| 73671 | | 73672 | 2.3/8" | 380 | 2700 |
| 73673 | | 73674 | 2.1/2" | | |
| 73675 | | 73676 | 2.5/8" | 400 | 3200 |
| 73677 | | 73678 | 2.3/4" | | |
| 73679 | | 73680 | 2.7/8" | 420 | 4200 |
| 73681 | | 73682 | 3" | | |

ESTRELLA DE GOLPE CURVA / CURVED SLOGGING RING WRENCH / CLE POLYGONALE A FRAPPER COURBEE
ZUGSCHLAGRINGSCHLÜSSEL, GEBOGEN / POLIGONALE AD IMPULSO A CURVA / RINGSLAGSLEUTEL GEBOGEN
CHAVE LUNETA CURVA DE PANCADA



mm

| Cu-Be | COD | Al-Bron |  |  |  |
|-------|-----|---------|---|---|---|
| 74137 | | 74138 | 24 | 160 | 300 |
| 74139 | | 74140 | 27 | 170 | 420 |
| 74141 | | 74142 | 30 | 180 | 500 |
| 74143 | | 74144 | 32 | 190 | 520 |
| 74145 | | 74146 | 36 | 210 | 800 |
| 74147 | | 74148 | 41 | 225 | 1000 |
| 74149 | | 74150 | 46 | 240 | 1200 |
| 74151 | | 74152 | 50 | 255 | 1500 |
| 74153 | | 74154 | 55 | 270 | 1800 |
| 74155 | | 74156 | 60 | 285 | 2200 |
| 74157 | | 74158 | 65 | 300 | 2400 |
| 74159 | | 74160 | 70 | 315 | 2800 |





LLAVES / WRENCHES / CLES / SCHLÜSSEL / CHIAVI / SLEUTELS / CHAVES

ESTRELLA DE UNA BOCA / SINGLE END RING WRENCH / CLE POLYGONALE / EINRINGSCHLÜSSEL / POLIGONALE UNA BOCCA
ENKELRINGSLEUTEL / CHAVE LUNETETA DE UMA BOCA

| mm | | COD |  |  |  |
|-------|---------|-----|---|---|---|
| Cu-Be | Al-Bron | | | | |
| 73993 | 73994 | | 8 | 100 | 25 |
| 73995 | 73996 | | 10 | 110 | 35 |
| 73997 | 73998 | | 12 | 120 | 50 |
| 73999 | 74000 | | 14 | 130 | 75 |
| 74001 | 74002 | | 16 | 145 | 120 |
| 74003 | 74004 | | 17 | 150 | 130 |
| 74005 | 74006 | | 18 | 160 | 135 |
| 74007 | 74008 | | 19 | 170 | 170 |
| 74009 | 74010 | | 20 | 175 | 180 |
| 74011 | 74012 | | 21 | 185 | 185 |
| 74013 | 74014 | | 22 | 190 | 195 |
| 74015 | 74016 | | 24 | 210 | 250 |
| 74017 | 74018 | | 27 | 230 | 340 |
| 74019 | 74020 | | 30 | 250 | 450 |
| 74021 | 74022 | | 32 | 270 | 500 |
| 74023 | 74024 | | 34 | 280 | 630 |
| 74025 | 74026 | | 36 | 290 | 750 |
| 74027 | 74028 | | 38 | 300 | 850 |
| 74029 | 74030 | | 41 | 310 | 960 |
| 74031 | 74032 | | 45 | 325 | 1200 |
| 74033 | 74034 | | 46 | 330 | 1250 |
| 74035 | 74036 | | 48 | 340 | 1400 |
| 74037 | 74038 | | 50 | 350 | 1500 |
| 74039 | 74040 | | 55 | 370 | 1700 |
| 74041 | 74042 | | 56 | 375 | 1750 |
| 74043 | 74044 | | 60 | 390 | 1900 |
| 74045 | 74046 | | 65 | 410 | 2200 |
| 74047 | 74048 | | 70 | 430 | 2600 |
| 74049 | 74050 | | 75 | 450 | 3200 |
| 74051 | 74052 | | 80 | 470 | 4000 |
| 74053 | 74054 | | 85 | 490 | 4400 |

ESTRELLA DE UNA BOCA CURVA / CURVED SINGLE END RING WRENCH / CLE POLYGONALE COURBEE / EINRINGSCHLÜSSEL,
GEBOGEN / POLIGONALE UNA BOCCA CURVA / ENKELRINGSLEUTEL GEBOGEN / CHAVE LUNETETA UMA BOCA CURVA

| mm | | COD |  |  |  |
|-------|---------|-----|---|---|---|
| Cu-Be | Al-Bron | | | | |
| 74056 | 74057 | | 10 | 120 | 65 |
| 74058 | 74059 | | 12 | 160 | 90 |
| 74060 | 74061 | | 14 | 150 | 95 |
| 74062 | 74063 | | 16 | 175 | 150 |
| 74064 | 74065 | | 17 | 175 | 150 |
| 74066 | 74067 | | 19 | 205 | 220 |
| 74068 | 74069 | | 22 | 205 | 220 |
| 74070 | 74071 | | 24 | 205 | 320 |
| 74072 | 74073 | | 27 | 205 | 320 |
| 74074 | 74075 | | 30 | 250 | 540 |
| 74076 | 74077 | | 32 | 250 | 570 |
| 74078 | 74079 | | 34 | 295 | 620 |
| 74080 | 74081 | | 36 | 295 | 620 |
| 74082 | 74083 | | 38 | 305 | 800 |
| 74084 | 74085 | | 41 | 305 | 800 |
| 74086 | 74087 | | 46 | 340 | 1000 |
| 74088 | 74089 | | 50 | 340 | 1500 |
| 74090 | 74091 | | 55 | 370 | 2000 |
| 74092 | 74093 | | 60 | 400 | 2400 |
| 74094 | 74095 | | 65 | 430 | 2500 |
| 74096 | 74097 | | 70 | 450 | 3500 |
| 74098 | 74099 | | 75 | 470 | 3900 |
| 74100 | 74101 | | 80 | 490 | 4200 |





Cu-Be cobre berilio / beryllium copper / cuivre beryllium / Kupfer Beryllium / koper beryllium / rame-berillio

Al-Bron aluminio bronce / aluminium bronze / alliage aluminium-bronze / Aluminium Bronze / aluminium brons / aluminio bronzo

LLAVES / WRENCHES / CLES / SCHLÜSSEL / CHIAVI / SLEUTELS / CHAVES

ESTRELLA DE UNA BOCA ACODADA / OFFSET SINGLE END RING WRENCH / CLE POLYGONALE CONTRE COUDEE
EINRINGSCHLÜSSEL, GEKRÖPFT / CHIAVE A GOMITO A STELLA UNA BOCCA / ENKELRINGSLEUTEL DIEP GEBOGEN
CHAVE LUNETA BOCA INCLINADA

| mm | | COD |  |  |  |
|-------|---------|-----|---|---|---|
| Cu-Be | Al-Bron | | | | |
| 74103 | 74104 | | 17 | 150 | 130 |
| 74105 | 74106 | | 19 | 170 | 170 |
| 74107 | 74108 | | 21 | 185 | 210 |
| 74109 | 74110 | | 22 | 190 | 220 |
| 74111 | 74112 | | 24 | 210 | 280 |
| 74113 | 74114 | | 27 | 230 | 350 |
| 74115 | 74116 | | 30 | 250 | 480 |
| 74117 | 74118 | | 32 | 270 | 600 |
| 74119 | 74120 | | 36 | 290 | 750 |





DE VALVULA CUADRADA / VALVE SQUARE / CLE A VANNE CARREE / VENTILSCHLÜSSEL / VALVOLA QUADRATA/ VENTIELSLEUTEL
CHAVE DE VÁLVULA QUADRADA

| mm | | COD |  |  |  |
|-------|---------|-----|---|---|---|
| Cu-Be | Al-Bron | | | | |
| 74162 | 74163 | | 6 | 110 | 60 |
| 74164 | 74165 | | 8 | 120 | 75 |
| 74166 | 74167 | | 9 | 140 | 90 |
| 74168 | 74169 | | 10 | 140 | 100 |
| 74170 | 74171 | | 11 | 160 | 120 |
| 74172 | 74173 | | 12 | 190 | 170 |
| 74174 | 74175 | | 13 | 200 | 180 |
| 74176 | 74177 | | 14 | 250 | 270 |
| 74178 | 74179 | | 16 | 250 | 300 |
| 74180 | 74181 | | 17 | 300 | 380 |
| 74182 | 74183 | | 19 | 350 | 680 |
| 74184 | 74185 | | 22 | 400 | 950 |
| 74186 | 74187 | | 24 | 500 | 1200 |



DE VASO CUADRADA / SQUARE SOCKET / DOUILLE CARREE / QUADRATISCHE EINSATZ / BUSSOLA QUADRATA / VIERKANTE
DOPSLEUTEL / CHAVE DE CAIXA QUADRADA

| mm | | COD |  |  |  |
|-------|---------|-----|---|---|---|
| Cu-Be | Al-Bron | | | | |
| 74189 | 74190 | | 3/8" | 155 | 180 |



La más galardonada

The most awarded

La plus primée

CABEZA FIJA / CROW FOOT OPEN END / TÊTE Á FOURCHE / HEBESTANGE / TESTA FISSA / BREEKIJZER / CABEÇA FIXA

| Cu-Be | COD | Al-Bron | | | | |
|-------|-----|---------|------|----------|----|-----|
| 72541 | | 72542 | 3/8" | 9/16" | 35 | |
| 72543 | | 72544 | | 5/8" | 37 | 50 |
| 72545 | | 72546 | | 11/16" | 38 | |
| 72547 | | 72548 | | 7/8" | 43 | 55 |
| 72549 | | 72550 | | 1.1/8" | 50 | 75 |
| 72551 | | 72552 | | 1.1/4" | 53 | 90 |
| 72553 | | 72554 | | 1.3/8" | 56 | 90 |
| 72555 | | 72556 | | 1.1/2" | 59 | 125 |
| 72557 | | 72558 | | 1.11/16" | 65 | 160 |
| 72559 | | 72560 | | 1.7/8" | 72 | 170 |
| 72561 | | 72562 | | 2" | 75 | 175 |
| 72563 | | 72564 | | 2.1/4" | 81 | 190 |

| Cu-Be | COD | Al-Bron | | | | |
|-------|-----|---------|------|----|----|-----|
| 72565 | | 72566 | 1/2" | 14 | 55 | |
| 72567 | | 72568 | | 16 | 60 | |
| 72569 | | 72570 | | 17 | 60 | |
| 72571 | | 72572 | | 19 | 49 | 100 |
| 72573 | | 72574 | | 20 | | |
| 72575 | | 72576 | | 22 | 52 | 105 |
| 72577 | | 72578 | | 25 | 56 | 125 |
| 72579 | | 72580 | | 27 | 59 | 130 |
| 72581 | | 72582 | | 28 | | |



LLAVE ESTRELLA DE EXTENSION / RING SPANNER FOR EXTENSION / CLE POLYAGONALE A EXTENSION / RINGSCHLÜSSEL MIT VERLÄNGERUNG / CHIAVE POLIGONALE PER ESTENSORI / RINGSLEUTEL MET VERLENGSTUK / CHAVE DE LUNETA DE EXTENSÃO

| Cu-Be | COD | Al-Bron | | | |
|-------|-----|---------|----|-----|-----|
| 73688 | | 73689 | 24 | 200 | 900 |
| 73472 | | 73396 | 27 | | |
| 70957 | | 70982 | 30 | | |
| 70958 | | 70983 | 32 | | |
| 70959 | | 70984 | 34 | | |
| 70960 | | 70985 | 35 | | |
| 70961 | | 70986 | 36 | | |
| 70962 | | 70987 | 37 | | |
| 70963 | | 70988 | 38 | | |
| 70964 | | 70989 | 41 | | |
| 70965 | | 70990 | 42 | | |
| 70966 | | 70991 | 46 | | |
| 70967 | | 70992 | 47 | | |
| 70968 | | 70993 | 50 | | |
| 70969 | | 70994 | 52 | | |
| 70970 | | 70995 | 54 | | |
| 70971 | | 70996 | 55 | | |
| 70972 | | 70997 | 56 | | |
| 70973 | | 70998 | 58 | | |
| 70974 | | 70999 | 60 | | |
| 70975 | | 71000 | 63 | | |
| 70976 | | 71001 | 65 | | |
| 70977 | | 71002 | 67 | | |
| 70978 | | 71003 | 70 | | |
| 70979 | | 71004 | 71 | | |
| 70980 | | 71005 | 75 | | |
| 70981 | | 71006 | 77 | | |



| COD | | | | |
|-------|-----|----|-------|------|
| 72605 | 600 | 22 | 30-41 | 900 |
| 72606 | 750 | 25 | 42-55 | 1600 |
| 72607 | 850 | 30 | 56-77 | 2500 |

latón / brass / laiton



Cu-Be cobre berilio / beryllium copper / cuivre beryllium / Kupfer Beryllium / koper beryllium / rame-berillio

Al-Bron aluminio bronce / aluminium bronze / alliage aluminium-bronze / Aluminium Bronze / aluminium brons / aluminio bronzo

LLAVES / WRENCHES / CLES / SCHLÜSSEL / CHIAVI / SLEUTELS / CHAVES



 FIJA DE UNA BOCA / SINGLE ENDED OPEN JAW SPANNER / A FOURCHE / EINMAULSCHLÜSSEL / FISSE SEMPLICE
 ENKELVOUDIGE STEEKSLEUTEL / FIXA DE UMA BOCA

mm

| Cu-Be | COD | |  |  |  |
|-------|---------|----|---|---|---|
| | Al-Bron | | | | |
| 70259 | 70936 | 6 | 83 | 40 | |
| 70260 | 70937 | 7 | 87 | | |
| 70261 | 70938 | 8 | 92 | | |
| 70262 | 70939 | 9 | 97 | | |
| 70263 | 70940 | 10 | 102 | | |
| 70264 | 70941 | 11 | 107 | | |
| 72939 | 71807 | 12 | 112 | 50 | |
| 72940 | 71808 | 13 | 118 | | |
| 70265 | 70942 | 14 | 124 | | |
| 72941 | 71809 | 15 | 130 | | |
| 72942 | 71810 | 16 | 136 | | |
| 70266 | 70943 | 17 | 143 | | |
| 72943 | 71811 | 18 | 150 | | |
| 70267 | 70944 | 19 | 157 | | |
| 72944 | 71812 | 20 | 164 | | 70 |
| 72945 | 71813 | 21 | 172 | | 85 |
| 70268 | 70945 | 22 | 180 | 100 | |
| 72946 | 71814 | 23 | 188 | 150 | |
| 70269 | 70946 | 24 | 196 | 200 | |
| 72947 | 71815 | 25 | 206 | | |
| 72948 | 71816 | 26 | 216 | | |
| 70270 | 70947 | 27 | 225 | | |
| 72949 | 71817 | 28 | 235 | | 250 |
| 72950 | 71818 | 29 | 245 | | 275 |
| 70271 | 70948 | 30 | 255 | 300 | |
| 72955 | 72911 | 31 | 262 | | |
| 70272 | 70949 | 32 | 275 | 400 | |
| 70273 | 70950 | 36 | 300 | | |
| 70274 | 70951 | 41 | 325 | 500 | |
| 70275 | 70952 | 46 | 350 | 1000 | |
| 70276 | 70953 | 50 | 375 | 1200 | |
| 70277 | 70954 | 55 | 400 | 1400 | |
| 70278 | 70955 | 60 | 425 | 2100 | |
| 70279 | 70956 | 65 | 450 | | |

 FIJA DE UNA BOCA ACODADA / OFFSET SINGLE OPEN END / CLE MIXTE CONTRE COUDEE / EINMAULSCHLÜSSEL GEKRÖPFT
 CHIAVE A GOMITO AD UNA BOCCA / ENKELSTEEKSLEUTEL DIEP GEBOGEN / CHAVE FIXA DE UMA BOCA INCLINADA

mm

| Cu-Be | COD | |  |  |  |
|-------|---------|----|---|---|---|
| | Al-Bron | | | | |
| 73909 | 73910 | 12 | 120 | 50 | |
| 73911 | 73912 | 14 | 130 | 80 | |
| 73913 | 73914 | 17 | 150 | 120 | |
| 73915 | 73916 | 19 | 170 | 170 | |
| 73917 | 73918 | 22 | 190 | 240 | |
| 73919 | 73920 | 24 | 210 | 250 | |
| 73921 | 73922 | 27 | 230 | 370 | |
| 73923 | 73924 | 30 | 250 | 470 | |
| 73925 | 73926 | 32 | 270 | 570 | |
| 73927 | 73928 | 34 | 280 | 700 | |
| 73929 | 73930 | 36 | 290 | 800 | |
| 73931 | 73932 | 41 | 310 | 1000 | |
| 73933 | 73934 | 46 | 330 | 1300 | |
| 73935 | 73936 | 50 | 350 | 1500 | |
| 73937 | 73938 | 55 | 370 | 2000 | |



LLAVES / WRENCHES / CLES / SCHLÜSSEL / CHIAVI / SLEUTELS / CHAVES

DE PIPA / ANGLED SOCKET / CLES A PIPE / PFEIFENSCHLÜSSEL / CHIAVI A PIPA / PIJPSLEUTEL / DE CACHIMBO

mm

| Cu-Be | COD | Al-Bron | | | |
|-------|-----|---------|----|-----|-----|
| 70417 | | 71361 | 8 | 107 | 300 |
| 70418 | | 71362 | 9 | | |
| 70419 | | 71363 | 11 | 161 | 400 |
| 73314 | | 73321 | 13 | | |
| 70420 | | 71364 | 14 | 211 | 450 |
| 70421 | | 71365 | 17 | | |
| 70422 | | 71366 | 19 | 244 | 500 |
| 70423 | | 71367 | 22 | | |
| 70424 | | 71368 | 24 | 250 | 550 |
| 70425 | | 71369 | 27 | | |
| 73317 | | 73324 | 30 | 300 | 700 |
| 72916 | | 72914 | 36 | | |
| 72917 | | 72915 | 41 | | |

LLAVE EN "T" / T-SOCKET WRENCH / DOUILLE EN "T" / T-STECKSCHLÜSSEL / T-DOP SLEUTEL / CHIAVE A T POLIGONALE
CHAVE DE CAIXA EM T

mm

| Cu-Be | COD | Al-Bron | | | |
|-------|-----|---------|----|-----|------|
| 71370 | | 71381 | 9 | 170 | 250 |
| 71371 | | 71382 | 11 | | |
| 71372 | | 71383 | 14 | 230 | 400 |
| 71373 | | 71384 | 17 | | |
| 71374 | | 71385 | 19 | 260 | 700 |
| 71375 | | 71386 | 22 | | |
| 71376 | | 71387 | 24 | 300 | 900 |
| 71377 | | 71388 | 27 | | |
| 71378 | | 71389 | 30 | 350 | 950 |
| 71379 | | 71390 | 32 | | |
| 72096 | | 72097 | 36 | 400 | 1000 |
| 71380 | | 71391 | 38 | | |

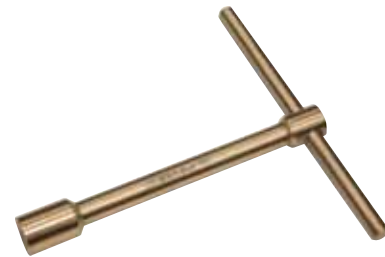

LLAVE EN "T" / "T" OPEN END WRENCH / CLE EN T / T-MAULSCHLÜSSEL / CHIAVE FISSA E T / T-STEEKSLEUTEL / CHAVE FIXA EM T

mm

| Cu-Be | COD | Al-Bron | | | |
|-------|-----|---------|----|-----|-----|
| 73951 | | 73952 | 8 | 215 | 130 |
| 73953 | | 73954 | 10 | | 140 |
| 73955 | | 73956 | 12 | | 145 |
| 73957 | | 73958 | 14 | | 450 |

HEXAGONAL EN "T" / T HEXAGONAL WRENCH / CLE HEXAGONALE EN T / T-HEX SCHLÜSSEL / CHIAVE ESAGONALE A T
T-HEX SLEUTEL / CHAVE HEXAGONAL EM T

mm

| Cu-Be | COD | Al-Bron | | | |
|-------|-----|---------|----|-----|------|
| 74192 | | 74193 | 10 | 150 | 250 |
| 74194 | | 74195 | 12 | 170 | 280 |
| 74196 | | 74197 | 14 | 170 | 380 |
| 74198 | | 74199 | 17 | 190 | 450 |
| 74200 | | 74201 | 19 | 220 | 590 |
| 74202 | | 74203 | 22 | 240 | 650 |
| 74204 | | 74205 | 24 | 260 | 900 |
| 74206 | | 74207 | 27 | 260 | 950 |
| 74208 | | 74209 | 30 | 280 | 1200 |
| 74210 | | 74211 | 32 | 280 | 1400 |
| 74212 | | 74213 | 36 | 300 | 1700 |
| 74214 | | 74215 | 41 | 300 | 1900 |



Cu-Be cobre berilio / beryllium copper / cuivre beryllium / Kupfer Beryllium / koper beryllium / rame-berillio

Al-Bron aluminio bronce / aluminium bronze / alliage aluminium-bronze / Aluminium Bronze / aluminium brons / aluminio bronzo

LLAVES / WRENCHES / CLES / SCHLÜSSEL / CHIAVI / SLEUTELS / CHAVES

LLAVES HEXAGONALES / HEXAGONAL KEYS / CLES MALES / INBUSSCHLÜSSEL / CHIAVI ESAGONALI / INBUSSLEUTELS
CHAVES HEXAGONAIS



mm

| COD | | mm | L mm | H mm | ° |
|-------|---------|-----|------|------|------|
| Cu-Be | Al-Bron | | | | |
| 72239 | 72238 | 1,5 | 65 | 13 | 5 |
| 70391 | 71287 | 2 | | | |
| 70392 | 71288 | 3 | | | |
| 70393 | 71289 | 4 | | | |
| 70394 | 71290 | 5 | | | |
| 70395 | 71291 | 6 | 90 | 32 | 30 |
| 70396 | 71292 | 7 | | | |
| 70397 | 71293 | 8 | 115 | 44 | 100 |
| 70398 | 71294 | 9 | | | |
| 70399 | 71295 | 10 | | | |
| 72241 | 72240 | 11 | 130 | 48 | 200 |
| 70400 | 71296 | 12 | 135 | 52 | |
| 72243 | 72242 | 13 | 140 | 54 | 250 |
| 70401 | 71297 | 14 | 155 | 58 | 300 |
| 70402 | 71298 | 17 | 175 | 65 | 500 |
| 72245 | 72244 | 18 | 180 | | 600 |
| 70403 | 71299 | 19 | 195 | 72 | 700 |
| 70404 | 71300 | 22 | 200 | 77 | 1000 |
| 70405 | 71301 | 24 | 210 | 82 | 1100 |
| 70406 | 71302 | 27 | 215 | 93 | 1600 |
| 70407 | 71303 | 32 | 230 | 116 | 2000 |
| 70408 | 71304 | 36 | 235 | 128 | 2700 |
| 70409 | 71305 | 41 | 240 | 140 | 3300 |

inch.

| COD | | inch | L mm | H mm | ° |
|-------|---------|---------|------|------|------|
| Cu-Be | Al-Bron | | | | |
| 71306 | 71330 | 1/8" | 65 | 24 | 10 |
| 71307 | 71331 | 9/64" | | | |
| 71308 | 71332 | 5/32" | | | |
| 71309 | 71333 | 3/16" | 90 | 31 | 30 |
| 71310 | 71334 | 7/32" | 95 | 37 | 40 |
| 71311 | 71335 | 1/4" | 105 | | |
| 71312 | 71336 | 5/16" | 115 | 44 | 100 |
| 71313 | 71337 | 3/8" | 120 | 45 | |
| 71314 | 71338 | 7/16" | 125 | 48 | |
| 71315 | 71339 | 1/2" | 140 | 55 | 250 |
| 71316 | 71340 | 9/16" | 155 | 58 | 300 |
| 71317 | 71341 | 5/8" | 160 | 63 | 400 |
| 71318 | 71342 | 11/16" | 180 | 65 | 600 |
| 71319 | 71343 | 3/4" | 195 | 73 | 700 |
| 71320 | 71344 | 7/8" | 200 | 79 | 1000 |
| 71321 | 71345 | 1" | 210 | 85 | 1300 |
| 71322 | 71346 | 1.1/16" | 215 | 93 | 1600 |
| 71323 | 71347 | 1.1/8" | 220 | 95 | 1800 |
| 71324 | 71348 | 1.1/4" | 230 | 116 | 2000 |
| 71325 | 71349 | 1.5/16" | | | 2200 |
| 71326 | 71350 | 1.3/8" | 235 | 128 | 2400 |
| 71327 | 71351 | 1.7/16" | | | 2700 |
| 71328 | 71352 | 1.1/2" | | | 3000 |
| 71329 | 71353 | 1.5/8" | 240 | 140 | 3500 |

LLAVES HEXAGONALES DE BOLA / BALLPOINT HEXAGONAL KEYS / CLES MALES A TETE SPHERIQUE
KUGELKOPF INBUSSCHLÜSSEL / CHIAVI ESAGONALI CON TESTA SFERICA / INBUSSLEUTEL MET BOLLE KOP
CHAVES HEXAGONAIS ESFERICAS

STANDARD

| COD | | mm | L mm | H mm | ° |
|-------|---------|----|------|------|-----|
| Cu-Be | Al-Bron | | | | |
| 72177 | 72184 | 3 | 65 | 24 | 5 |
| 72178 | 72185 | 4 | 73 | 29 | 10 |
| 72179 | 72186 | 5 | 83 | 34 | 20 |
| 72180 | 72187 | 6 | 94 | 38 | 30 |
| 72181 | 72188 | 8 | 106 | 43 | 60 |
| 72182 | 72189 | 10 | 121 | 47 | 105 |
| 72183 | 72190 | 12 | 137 | 53 | 170 |



SERIE LARGA / LONG PATTERN / SERIE LONGUE / LANGE SCHNKL / SERIE LUNGA / VERLENGD MODEL / SERIE LONGA

| COD | | mm | L mm | H mm | ° |
|-------|---------|----|------|------|-----|
| Cu-Be | Al-Bron | | | | |
| 70410 | 71354 | 3 | 128 | 26 | 8 |
| 70411 | 71355 | 4 | 144 | 30 | 17 |
| 70412 | 71356 | 5 | 163 | 34 | 31 |
| 70413 | 71357 | 6 | 184 | 41 | 51 |
| 70414 | 71358 | 8 | 190 | 47 | 100 |
| 70415 | 71359 | 10 | 220 | 54 | 150 |
| 70416 | 71360 | 12 | 270 | 60 | 350 |



LLAVES DE VASO / SOCKET WRENCHES / DOUILLES / STECKSCHLÜSSEL / BUSSOLE / DOPPEN / CHAVES DE CAIXA

1/4"



mm



COD

inch.



COD

| Cu-Be | Al-Bron | 1/4" | 25 | 10 |
|-------|---------|------|----|----|
| 71909 | 71930 | 4 | 25 | 10 |
| 71910 | 71931 | 5 | | |
| 71911 | 71932 | 6 | | |
| 71912 | 71933 | 7 | | |
| 71913 | 71934 | 8 | | |
| 71914 | 71935 | 9 | | |
| 71915 | 71936 | 10 | | |
| 71916 | 71937 | 11 | 20 | 15 |
| 71917 | 71938 | 12 | | |
| 71918 | 71939 | 13 | | |
| 71919 | 71940 | 14 | 26 | 25 |

| Cu-Be | Al-Bron | 1/4" | 25 | 10 | | |
|-------|---------|--------|----|----|----|----|
| 71920 | 71941 | 3/16" | 25 | 10 | | |
| 71921 | 71942 | 7/32" | | | | |
| 71922 | 71943 | 1/4" | | | | |
| 71923 | 71944 | 9/32" | | | | |
| 71924 | 71945 | 5/16" | | | | |
| 71925 | 71946 | 11/32" | | | 28 | 15 |
| 71926 | 71947 | 3/8" | | | | |
| 71927 | 71948 | 7/16" | | | | |
| 71928 | 71949 | 1/2" | 28 | 20 | | |
| 71929 | 71950 | 9/16" | | | 25 | |

LLAVE DE CARRACA REVERSIBLE / REVERSIBLE RATCHET HANDLE / CLE A CLIQUET / UMSCHALTKNARRE
CHIAVE A CRICCO REVERSIBLE / RATEL MET OMKEERMECHANISME / ROQUETE REVERSIVEL

| Cu-Be | Al-Bron | 1/4" | 130 | 400 |
|-------|---------|------|-----|-----|
| 71955 | 71956 | 1/4" | 130 | 400 |



CARRACA MACHO-HEMBRA / MALE-FEMALE RATCHET / CLIQUET MALE-FEMELLE / RATSCHER DOPPELT FUNKTION
CRICCO MASCHIO-FEMMINA / RATEL DUBBELE FUNCTIE / ROQUETE MACHO-FÊMEA

| Cu-Be | Al-Bron | 1/4" | 200 | 350 |
|-------|---------|------|-----|-----|
| 73722 | 73723 | 1/4" | 200 | 350 |



MANGO CORREDIZO EN "T" / SLIDING "T" HANDLE / POIGNEE COULISSANTE / T-GLEITGRIFF / ASTA CON QUADRO SCORREVOLO "T" WRINGSTAAF / CABO "T" CORREDIÇO

| Cu-Be | Al-Bron | 1/4" | 254 | 250 |
|-------|---------|------|-----|-----|
| 71957 | 71958 | 10" | 254 | 250 |



ALARGADERA / EXTENSION / RALLONGE / VERLÄNGERUNG / PROLUNGA / VERLENGSTUK / EXTENÇÃO

| Cu-Be | Al-Bron | 1/4" | 101 | 200 |
|-------|---------|------|-----|-----|
| 71959 | 71961 | 4" | 101 | 200 |
| 71960 | 71962 | 8" | 203 | 400 |



ARTICULACION UNIVERSAL / UNIVERSAL JOINT / CARDAN UNIVERSEL / KARDANGELENK / SNODO CARDANICO
DOP MET CARDANGEWIRICH / CARDAN UNIVERSAL

| Cu-Be | Al-Bron | 1/4" | 55 | 150 |
|-------|---------|------|----|-----|
| 71953 | 71954 | 1/4" | 55 | 150 |



ADAPTADOR / ADAPTER / ADAPTATEUR / VERBINDUNGSTEILE / ADATTATORE / ADAPTOR / PEÇA DE CONEXÃO

| Cu-Be | Al-Bron | 1/4"-1/2" | 100 |
|-------|---------|-----------|-----|
| 71951 | 71952 | 1/4"-1/2" | 100 |



ANTICHISPA / NON-SPARKING / ANTI-DEFLAGRANT / FUNKENFREI ANTISCINTILLA / VONKVRIJE / ANTI-DEFLAGRANTE

PUNTA HEXAGONAL CON VASO / HEX BIT SOCKET / EMBOUT HEXAGONAL A DOUILLE / HEX SCHRAUBENDREHEREINSATZ
PUNTA ESAGONALE CON BUSSOLA / HEX DOPSLEUTELINZET / PONTA HEXAGONAL COM CHAVE DE CAIXA

| COD | | | | | |
|-------|---------|----|------|----|----|
| Cu-Be | Al-Bron | | | | |
| 73692 | 73693 | 3 | 1/4" | 55 | 20 |
| 73694 | 73695 | 4 | | | |
| 73696 | 73697 | 5 | | | |
| 73698 | 73699 | 6 | | | |
| 73700 | 73701 | 7 | | | |
| 73702 | 73703 | 8 | | 65 | 55 |
| 73704 | 73705 | 9 | | | |
| 73706 | 73707 | 10 | | | |
| | | | | | |
| | | | | | |



DESTORNILLADOR PORTAVASOS / SOCKET HOLDER / TOURNEVIS PORTE DOUILLE / SCHRAUBENDREHERHALTER / CACCIAVITI
PORTABUSSOLE / DOPSLEUTELHOUDER / CHAVE PORTA CHAVES DE CAIXA

| COD | | | | | |
|-------|---------|------|----|-----|----|
| Cu-Be | Al-Bron | | | | |
| 73731 | 73732 | 1/4" | 55 | 195 | 60 |



LLAVES DE VASO / SOCKET WRENCHES / DOUILLES / STECKSCHLÜSSEL / BUSSOLE /
DOPPEN / CHAVES DE CAIXA

1/2"



| COD | | | | | | | | | | | | |
|-------|---------|----|----|-----|---------|-----|----|----|----|-------|-------|----|
| Cu-Be | Al-Bron | | | | | | | | | | | |
| 70319 | 71158 | 6 | 40 | 60 | 1/4" | 40 | 60 | | | | | |
| 70320 | 71159 | 7 | | | | | | | | | | |
| 70321 | 71160 | 8 | | | | | | | | | | |
| 70322 | 71161 | 9 | | | | | | | | | | |
| 70323 | 71162 | 10 | | | | | | | | | | |
| 70324 | 71163 | 11 | | | | | | | | | | |
| 70325 | 71164 | 12 | | | | | | | | | | |
| 70326 | 71165 | 13 | | | | | | | | | | |
| 70327 | 71166 | 14 | | | | | | | | | | |
| 70328 | 71167 | 15 | | | | | | | 80 | 70 | 5/16" | 70 |
| 70329 | 71168 | 16 | | | | | | | | | | |
| 70330 | 71169 | 17 | | | | | | | | | | |
| 70331 | 71170 | 18 | | | | | | | | | | |
| 70332 | 71171 | 19 | | | | | | | | | | |
| 70333 | 71172 | 20 | | | | | | | | | | |
| 70334 | 71173 | 21 | | | | | | | | | | |
| 70335 | 71174 | 22 | | | | | | | | | | |
| 70336 | 71175 | 23 | | | | | | | | | | |
| 70337 | 71176 | 24 | 90 | 80 | 3/8" | 80 | | | | | | |
| 70338 | 71177 | 25 | | | | | | | | | | |
| 70339 | 71178 | 26 | | | | | | | | | | |
| 70340 | 71179 | 27 | | | | | | | | | | |
| 70341 | 71180 | 28 | | | | | | | | | | |
| 70342 | 71181 | 29 | | | | | | | | | | |
| 70343 | 71182 | 30 | | | | | | | | | | |
| 70344 | 71183 | 32 | | | | | | | | | | |
| | | | | | | | | 42 | 70 | 7/16" | 70 | |
| | | | | | | | | | | | | |
| | | | | | | | | | | | | |
| | | | | | | | | | | | | |
| | | | | | | | | | | | | |
| | | | | | | | | | | | | |
| | | | | | | | | | | | | |
| | | | | | | | | | | | | |
| | | | | | | | | | | | | |
| | | | | | | | | | | | | |
| | | | 43 | 80 | 1/2" | 80 | | | | | | |
| | | | | | | | | | | | | |
| | | | | | | | | | | | | |
| | | | | | | | | | | | | |
| | | | | | | | | | | | | |
| | | | | | | | | | | | | |
| | | | | | | | | | | | | |
| | | | | | | | | | | | | |
| | | | | | | | | | | | | |
| | | | | | | | | | | | | |
| | | | 46 | 90 | 9/16" | 90 | | | | | | |
| | | | | | | | | | | | | |
| | | | | | | | | | | | | |
| | | | | | | | | | | | | |
| | | | | | | | | | | | | |
| | | | | | | | | | | | | |
| | | | | | | | | | | | | |
| | | | | | | | | | | | | |
| | | | | | | | | | | | | |
| | | | | | | | | | | | | |
| | | | 43 | 100 | 19/32" | 100 | | | | | | |
| | | | | | | | | | | | | |
| | | | | | | | | | | | | |
| | | | | | | | | | | | | |
| | | | | | | | | | | | | |
| | | | | | | | | | | | | |
| | | | | | | | | | | | | |
| | | | | | | | | | | | | |
| | | | | | | | | | | | | |
| | | | | | | | | | | | | |
| | | | 46 | 200 | 5/8" | 200 | | | | | | |
| | | | | | | | | | | | | |
| | | | | | | | | | | | | |
| | | | | | | | | | | | | |
| | | | | | | | | | | | | |
| | | | | | | | | | | | | |
| | | | | | | | | | | | | |
| | | | | | | | | | | | | |
| | | | | | | | | | | | | |
| | | | | | | | | | | | | |
| | | | 47 | 100 | 11/16" | 100 | | | | | | |
| | | | | | | | | | | | | |
| | | | | | | | | | | | | |
| | | | | | | | | | | | | |
| | | | | | | | | | | | | |
| | | | | | | | | | | | | |
| | | | | | | | | | | | | |
| | | | | | | | | | | | | |
| | | | | | | | | | | | | |
| | | | | | | | | | | | | |
| | | | 46 | 200 | 8/8" | 200 | | | | | | |
| | | | | | | | | | | | | |
| | | | | | | | | | | | | |
| | | | | | | | | | | | | |
| | | | | | | | | | | | | |
| | | | | | | | | | | | | |
| | | | | | | | | | | | | |
| | | | | | | | | | | | | |
| | | | | | | | | | | | | |
| | | | | | | | | | | | | |
| | | | 47 | 200 | 1.1/16" | 200 | | | | | | |
| | | | | | | | | | | | | |
| | | | | | | | | | | | | |
| | | | | | | | | | | | | |
| | | | | | | | | | | | | |
| | | | | | | | | | | | | |
| | | | | | | | | | | | | |
| | | | | | | | | | | | | |
| | | | | | | | | | | | | |
| | | | | | | | | | | | | |
| | | | 47 | 200 | 1.1/8" | 200 | | | | | | |
| | | | | | | | | | | | | |
| | | | | | | | | | | | | |
| | | | | | | | | | | | | |
| | | | | | | | | | | | | |
| | | | | | | | | | | | | |
| | | | | | | | | | | | | |
| | | | | | | | | | | | | |
| | | | | | | | | | | | | |
| | | | | | | | | | | | | |
| | | | 47 | 200 | 1.1/4" | 200 | | | | | | |
| | | | | | | | | | | | | |
| | | | | | | | | | | | | |
| | | | | | | | | | | | | |
| | | | | | | | | | | | | |
| | | | | | | | | | | | | |
| | | | | | | | | | | | | |
| | | | | | | | | | | | | |
| | | | | | | | | | | | | |
| | | | | | | | | | | | | |

LLAVE DE CARRACA REVERSIBLE / REVERSIBLE RATCHET HANDLE / CLE A CLIQUET / UMSCHALTKNARRE
CHIAVE A CRICCO REVERSIBILE / RATEL MET OMKEERMECHANISME / ROQUETE REVERSIVEL

| COD | | | | |
|-------|---------|------|-----|-----|
| Cu-Be | Al-Bron | | | |
| 70375 | 71272 | 1/2" | 250 | 600 |





CARRACA MACHO-HEMBRA / MALE-FEMALE RATCHET / CLIQUET MALE-FEMELLE / RATSCHKE DOPPELT FUNKTION
CRICCO MASCHIO-FEMMINA / RATEL DUBBELE FUNCTIE / ROQUETE MACHO-FÊMEA

| COD | | | | |
|-------|---------|------|-----|-----|
| Cu-Be | Al-Bron | | | |
| 73724 | 73725 | 1/2" | 250 | 450 |





MANGO CORREDIZO EN "T" / SLIDING "T" HANDLE / POIGNEE COULISSANTE / T-GLEITGRIFF / ASTA CON QUADRO SCORREVOLO "T" WRINGSTAAF / CABO "T" CORREDIÇO

| COD | | |  |  |
|-------|---------|------|---|---|
| Cu-Be | Al-Bron | 1/2" | | |
| 70378 | 71274 | 10" | 254 | 400 |
| 70379 | 71275 | 12" | 304 | 500 |





MANGO ARTICULADO / HINGED HANDLE / MANCHE ARTICULÉ / GELENKGRIFF / SCHARNIERSLEUTEL / MANICO ARTICOLATO CABO ARTICULADO

| COD | | |  |  |
|-------|---------|-----|---|---|
| Cu-Be | Al-Bron | | | |
| 72400 | 72401 | 230 | | 330 |
| 72402 | 72403 | 330 | | 400 |
| 72404 | 72405 | 410 | | 550 |



MANGO ACODADO / OFFSET HANDLE / MANCHE CONTRE COUDÉ / GEKRÖPFTE HANDGRIFF / GEBOGEN HANDVAT
DOPPIO MANICO / CABO DESALINHADO

| COD | | |  |  |
|-------|---------|-----|---|---|
| Cu-Be | Al-Bron | | | |
| 72410 | 72411 | 230 | | 400 |





PUNTA PLANA CON VASO / FLAT BIT SOCKET / EMBOUT FENTE A DOUILLE / FLACHE SCHRAUBENDREHEREINSATZ
PUNTA PIATTA CON BUSSOLA / VLAKE DOPSLEUTELINZET / PONTA DE FENDA COM CHAVE DE CAIXA

| COD | | |  |  |  |
|-------|---------|--------|---|---|--|
| Cu-Be | Al-Bron | 13x2mm | 1/2" | 52 | 100 |
| 73709 | 73710 | | | | |





NEW

BERBIQUÍ / SPEEDER HANDLE / VILBEBREQUIN / WINDE / LEVA GIROBECCHINO / OMSLAG / MANIVELA

| COD | | |  |  |
|-------|---------|-----|---|---|
| Cu-Be | Al-Bron | | | |
| 72416 | 72417 | 390 | | 750 |





ALARGADERA / EXTENSION / RALLONGE / VERLÄNGERUNG / PROLUNGA / VERLENGSTUK / EXTENÇÃO

| COD | | |  |  |
|-------|---------|------|---|---|
| Cu-Be | Al-Bron | 1/2" | | |
| 70383 | 71279 | 4" | 101 | 200 |
| 70384 | 71280 | 8" | 203 | 400 |
| 70385 | 71281 | 10" | 254 | 500 |





ARTICULACION UNIVERSAL / UNIVERSAL JOINT / CARDAN UNIVERSEL / KARDANGELNENK / SNODO CARDANICO DOP MET CARDANGEWIRCH / CARDAN UNIVERSAL

| COD | | |  |  |  |
|-------|---------|------|---|---|---|
| Cu-Be | Al-Bron | 1/2" | 80 | 200 | |
| 70372 | 71269 | | | | |



ADAPTADOR / ADAPTER / ADAPTATEUR / VERBINDUNGSTEILE / ADATTATORE / ADAPTOR / PEÇA DE CONEXÃO

| COD | | |  |  |  |
|-------|---------|-----------|---|---|---|
| Cu-Be | Al-Bron | | | | |
| 70368 | 71265 | 3/4"-1/2" | 55 | 200 | |
| 70369 | 71266 | 1/2"-3/4" | 50 | | |
| 70370 | 71267 | 1"-3/4" | 70 | 600 | |
| 70371 | 71268 | 3/4"-1" | 60 | 410 | |



Cu-Be cobre berilio / beryllium copper / cuivre beryllium / Kupfer Beryllium / koper beryllium / rame-berillio

Al-Bron aluminio bronce / aluminium bronze / alliage aluminium-bronze / Aluminium Bronze / aluminium brons / aluminio bronz

LLAVES DE VASO / SOCKET WRENCHES / DOUILLES / STECKSCHLÜSSEL / BUSSOLE /
DOPPEN / CHAVES DE CAIXA

3/4"



mm

| COD | | Ø (mm) | L (mm) | UP |
|-------|---------|--------|--------|-----|
| Cu-Be | Al-Bron | | | |
| 70345 | 71220 | 24 | 55 | 200 |
| 71908 | 72953 | 26 | | |
| 70346 | 71221 | 27 | | |
| 70347 | 71222 | 30 | | |
| 70348 | 71223 | 32 | | |

inch.

| COD | | Ø (inch) | L (inch) | UP |
|-------|---------|----------|----------|-----|
| Cu-Be | Al-Bron | | | |
| 71228 | 71239 | 1.5/16" | 60 | 200 |
| 71229 | 71240 | 1.3/8" | | |

mm

| COD | | Ø (mm) | L (mm) | UP |
|-------|---------|--------|--------|-----|
| Cu-Be | Al-Bron | | | |
| 70349 | 71224 | 36 | 60 | 300 |
| 70350 | 71225 | 41 | 65 | 400 |
| 70351 | 71226 | 46 | 70 | 500 |
| 70352 | 71227 | 50 | 70 | 600 |

inch.

| COD | | Ø (inch) | L (inch) | UP |
|-------|---------|----------|----------|-----|
| Cu-Be | Al-Bron | | | |
| 71230 | 71241 | 1.7/16" | 60 | 300 |
| 71231 | 71242 | 1.1/2" | | |
| 71232 | 71243 | 1.9/16" | 65 | 350 |
| 71233 | 71244 | 1.5/8" | | |
| 71234 | 71245 | 1.11/16" | | |
| 71235 | 71246 | 1.3/4" | | |
| 71236 | 71247 | 1.13/16" | | |
| 71237 | 71248 | 1.7/8" | 70 | 600 |
| 71238 | 71249 | 2" | | |

CARRACA MACHO-HEMBRA / MALE-FEMALE RATCHET / CLIQUET MALE-FEMELLE / RATSCHKE DOPPELT FUNKTION
CRICCO MASCHIO-FEMMINA / RATEL DUBBELE FUNCTIE / ROQUETE MACHO-FÊMEA

| COD | | Ø (inch) | L (mm) | UP |
|-------|---------|----------|--------|------|
| Cu-Be | Al-Bron | | | |
| 73726 | 73727 | 3/4" | 300 | 1000 |



LLAVE DE CARRACA REVERSIBLE / REVERSIBLE RATCHET HANDLE / CLE A CLIQUET / UMSCHALTKNARRE
CHIAVE A CRICCO REVERSIBLE / RATEL MET OMKEERMECHANISME / ROQUETE REVERSIVEL

| COD | | Ø (inch) | L (mm) | UP |
|-------|---------|----------|--------|------|
| Cu-Be | Al-Bron | | | |
| 70376 | 71273 | 3/4" | 390 | 1400 |



CABEZA DE CARRACA / RATCHET HEAD / TETE DE CLIQUET / RATSCHKE KOPF / TESTA A CRICCO / RATELKOP
CABEÇA DE ROQUETE

| COD | | Ø (inch) | Ø (mm) | L (mm) | UP |
|-------|---------|----------|--------|--------|------|
| Cu-Be | Al-Bron | | | | |
| 73712 | 73713 | 3/4" | 21 | 160 | 1500 |



MANGO CORREDIZO EN "T" / SLIDING "T" HANDLE / POIGNEE COULISSANTE / T-GLEITGRIFF / ASTA CON QUADRO SCORREVOLO
"T" WRINGSTAAF / CABO "T" CORREDIÇO

| COD | | Ø (inch) | L (mm) | UP |
|-------|---------|----------|--------|------|
| Cu-Be | Al-Bron | | | |
| 70380 | 71276 | 10" | 254 | 900 |
| 70381 | 71277 | 18" | 457 | 1700 |



MANGO CORREDIZO EN "T" LARGO / LONG SLIDING "T" HANDLE / POIGNÉE COULISSANTE LONGUE / LANGE T-GRIFF MIT GLEITSTÜCK / MANICO LUNGO SCORREVOLE A T / LANGE T-GREEP MET GLIJSTUK / CABO T CORREDIÇO LONGO

| COD | | | | | |
|-------|---------|------|-----|-----|------|
| Cu-Be | Al-Bron | | | | |
| 73717 | 73718 | 3/4" | 350 | 190 | 1500 |



MANGO ARTICULADO / HINGED HANDLE / MANCHE ARTICULÉ / GELENKGRIF / SCHARNIERSLEUTEL / MANICO ARTICOLATO
CABO ARTICULADO

| COD | | | |
|-------|---------|-----|-----|
| Cu-Be | Al-Bron | | |
| 72406 | 72407 | 295 | 600 |



MANGO ACODADO / OFFSET HANDLE / MANCHE CONTRE COUDÉ / GEKRÖPFTE HANDGRIFF / GEBOGEN HANDVAT
DOPPIO MANICO / CABO DESALINHADO

| COD | | | |
|-------|---------|-----|-----|
| Cu-Be | Al-Bron | | |
| 72412 | 72413 | 280 | 700 |



ALARGADERA / EXTENSION / RALLONGE / VERLÄNGERUNG / PROLUNGA / VERLENGSTUK / EXTENÇÃO

| COD | | | | |
|-------|---------|------|-----|-----|
| Cu-Be | Al-Bron | 3/4" | | |
| 70386 | 71282 | 4" | 101 | 200 |
| 70387 | 71283 | 8" | 203 | 400 |
| 70388 | 71284 | 10" | 254 | 500 |



ARTICULACION UNIVERSAL / UNIVERSAL JOINT / CARDAN UNIVERSEL / KARDANGELENK / SNODO CARDANICO DOP MET CARDANGEWIRCH / CARDAN UNIVERSAL

| COD | | | | |
|-------|---------|------|-----|-----|
| Cu-Be | Al-Bron | 3/4" | | |
| 70373 | 71270 | 3/4" | 135 | 600 |



ARTICULACIÓN FLEXIBLE / FLEXIBLE JOINT / ARTICULATION FLEXIBLE / FLEXIBLE VERBINDUNG / FLEXIBELE VERBINDING
ARTICOLAZIONE FLESSIBILE / ARTICULAÇÃO FLEXÍVEL

| COD | | | | |
|-------|---------|-----|------|-----|
| Cu-Be | Al-Bron | | Ø mm | |
| 72396 | 72397 | 120 | 21 | 800 |



ADAPTADOR / ADAPTER / ADAPTATEUR / VERBINDUNGSTEILE / ADATTATORE / ADAPTOR / PEÇA DE CONEXÃO

| COD | | | |
|-------|---------|-----------|-----|
| Cu-Be | Al-Bron | | |
| 70368 | 71265 | 3/4"-1/2" | 200 |
| 70369 | 71266 | 1/2"-3/4" | |
| 70370 | 71267 | 1"-3/4" | 600 |
| 70371 | 71268 | 3/4"-1" | 410 |



LLAVES DE VASO / SOCKET WRENCHES / DOUILLES / STECKSCHLÜSSEL / BUSSOLE /
DOPPEN / CHAVES DE CAIXA

1"

mm

| COD | | | | |
|-------|---------|-----|----|------|
| Cu-Be | Al-Bron | | | |
| 70353 | 71250 | 41 | 65 | 1100 |
| 70354 | 71251 | 42 | | |
| 70355 | 71252 | 46 | 70 | 1200 |
| 70356 | 71253 | 50 | | |
| 70357 | 71254 | 55 | 75 | 1500 |
| 70358 | 71255 | 60 | | |
| 70359 | 71256 | 65 | 80 | 2200 |
| 70360 | 71257 | 70 | | |
| 70361 | 71258 | 75 | 85 | 3300 |
| 70362 | 71259 | 80 | | |
| 70363 | 71260 | 85 | 90 | 4600 |
| 70364 | 71261 | 90 | | |
| 70365 | 71262 | 95 | 95 | 4800 |
| 70366 | 71263 | 100 | | |
| 70367 | 71264 | 105 | | 5000 |



LLAVE DE CARRACA REVERSIBLE / REVERSIBLE RATCHET HANDLE / CLE A CLIQUET / UMSCHALTKNARRE
CHIAVE A CRICCO REVERSIBLE / RATEL MET OMKEERMECHANISME / ROQUETE REVERSIVEL

| COD | | | | |
|-------|---------|----|-----|------|
| Cu-Be | Al-Bron | | | |
| 72630 | 72629 | 1" | 550 | 1600 |



CABEZA DE CARRACA / RATCHET HEAD / TETE DE CLIQUET / RATSCH KOPF / TESTA A CRICCO / RATELKOP
CABEÇA DE ROQUETE

| COD | | | | | |
|-------|---------|----|--------|-----|------|
| Cu-Be | Al-Bron | | Ø (mm) | | |
| 73714 | 73715 | 1" | 23 | 180 | 3000 |

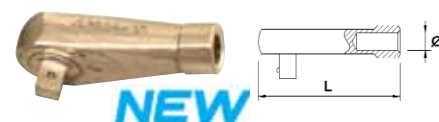

CARRACA MACHO-HEMBRA / MALE-FEMALE RATCHET / CLIQUET MALE-FEMELLE / RATSCH DOPPELT FUNKTION
CRICCO MASCHIO-FEMMINA / RATEL DUBBELE FUNCTIE / ROQUETE MACHO-FÊMEA

| COD | | | | |
|-------|---------|----|-----|------|
| Cu-Be | Al-Bron | | | |
| 73728 | 73729 | 1" | 300 | 1000 |



MANGO CORREDIZO EN "T" / SLIDING "T" HANDLE / POIGNEE COULISSANTE / T-GLEITGRIF / ASTA CON QUADRO SCORREVOLO
LO "T" WRINGSTAAF / CABO "T" CORREDIÇO

| COD | | | | |
|-------|---------|-----|-----|------|
| Cu-Be | Al-Bron | | | |
| 70382 | 71278 | 12" | 304 | 2300 |



MANGO CORREDIZO EN "T" LARGO / LONG SLIDING "T" HANDLE / POIGNÉE COULISSANTE LONGUE / LANGE T-GRIFF MIT
GLEITSTÜCK / MANICO LUNGO SCORREVOLE A T / LANGE T-GREEP MET GLIJSTUK / CABO T CORREDIÇO LONGO

| COD | | | | | |
|-------|---------|----|-----|-----|------|
| Cu-Be | Al-Bron | | | | |
| 73719 | 73720 | 1" | 400 | 190 | 2400 |



ALARGADERA / EXTENSION / RALLONGE / VERLÄNGERUNG / PROLUNGA / VERLENGSTUK / EXTENÇÃO

| COD | | | | |
|-------|---------|-----|-----|-----|
| Cu-Be | Al-Bron | 1" | | |
| 70389 | 71285 | 4" | 101 | 400 |
| 70390 | 71286 | 10" | 254 | 800 |



ADAPTADOR / ADAPTER / ADAPTATEUR / VERBINDUNGSTEILE / ADATTATORE / ADAPTOR / PEÇA DE CONEXÃO

| COD | | | |
|-------|---------|-----------|-----|
| Cu-Be | Al-Bron | | |
| 70368 | 71265 | 3/4"-1/2" | 200 |
| 70369 | 71266 | 1/2"-3/4" | |
| 70370 | 71267 | 1"-3/4" | 600 |
| 70371 | 71268 | 3/4"-1" | 410 |



ARTICULACION UNIVERSAL / UNIVERSAL JOINT / CARDAN UNIVERSEL / KARDANGELENK / SNODO CARDANICO DOP MET CARDANGEWIRCH / CARDAN UNIVERSAL

| COD | | | | |
|-------|---------|----|-----|------|
| Cu-Be | Al-Bron | 1" | | |
| 70374 | 71271 | 1" | 147 | 1300 |

ARTICULACIÓN FLEXIBLE / FLEXIBLE JOINT / ARTICULATION FLEXIBLE / FLEXIBLE VERBINDUNG / FLEXIBELE VERBINDING
ARTICOLAZIONE FLESSIBILE / ARTICULAÇÃO FLEXÍVEL

| COD | | | | |
|-------|---------|-----|----|------|
| Cu-Be | Al-Bron | | | |
| 72398 | 72399 | 120 | 21 | 1100 |

MANGO ARTICULADO / HINGED HANDLE / MANCHE ARTICULÉ / GELENKGRIF / SCHARNIERSLEUTEL / MANICO ARTICOLATO
CABO ARTICULADO

| COD | | | | |
|-------|---------|-----|--|-----|
| Cu-Be | Al-Bron | | | |
| 72408 | 72409 | 315 | | 850 |

MANGO ACODADO / OFFSET HANDLE / MANCHE CONTRE COUDÉ / GEKRÖPFTE HANDGRIF / GEBOGEN HANDVAT
DOPPIO MANICO / CABO DESALINHADO



| COD | | | | |
|-------|---------|-----|--|------|
| Cu-Be | Al-Bron | | | |
| 72414 | 72415 | 300 | | 1100 |



Cu-Be cobre berilio / beryllium copper / cuivre beryllium / Kupfer Beryllium / koper beryllium / rame-berillio

Al-Bron aluminio bronce / aluminium bronze / alliage aluminium-bronze / Aluminium Bronze / aluminium brons / aluminio bronzo



SET

| COD | | PCS. |  |  |  |
|-------|---------|------|---|---|---|
| Cu-Be | Al-Bron | | | | |
| 74263 | 74264 | 9 | 1/2" | 10-11-12-14-17-19-22-24mm | 1,4 |

| Especificaciones técnicas / Technical specification / Détails techniques | |
|--|-------|
| Mango acodado / Offset handle / Manche contre coudé | 230mm |





NEW

| COD | | PCS. |  |  |  |
|-------|---------|------|---|---|---|
| Cu-Be | Al-Bron | | | | |
| 74265 | 74266 | 12 | 1/2" | 8-10-11-12-14-17-19-22-24-27mm | 2,3 |

| Especificaciones técnicas / Technical specification / Détails techniques | |
|--|-------|
| Carraca / Ratchet / Cliquet | 250mm |
| Mango articulado / Hinged handle / Manche articulé | 230mm |





NEW

| COD | | PCS. |  |  |  |
|-------|---------|------|---|---|---|
| Cu-Be | Al-Bron | | | | |
| 74267 | 74268 | 16 | 1/2" | 10-11-12-14-17-19-22-24-27-30-32mm | 4,3 |

| Especificaciones técnicas / Technical specification / Détails techniques | |
|--|-----------|
| Carraca / Ratchet / Cliquet | 250mm |
| Mango corredizo en T / Sliding T handle / Poigne coulissante | |
| Berbiqui / Speeder handle / Vilebrequin | 390mm |
| Alargadera / Extension / Rallonge | 125-250mm |





NEW

| COD | | PCS. |  |  |  |
|-------|---------|------|---|---|---|
| Cu-Be | Al-Bron | | | | |
| 74269 | 74270 | 24 | 1/2" | 10-11-12-13-14-15-16-17-18-19-20-21-22-23-24-27-30-32mm | 5,3 |

| Especificaciones técnicas / Technical specification / Détails techniques | |
|--|-----------|
| Carraca / Ratchet / Cliquet | 250mm |
| Mango corredizo en T / Sliding T handle / Poigne coulissante | |
| Berbiqui / Speeder handle / Vilebrequin | 390mm |
| Alargadera / Extension / Rallonge | 125-250mm |
| Articulacion universal / Universal Joint / Cardan Universel | 75mm |



NEW

| COD | | PCS. |  |  |  |
|-------|---------|------|---|---|---|
| Cu-Be | Al-Bron | | | | |
| 74271 | 74272 | 27 | 1/2" | 10-11-12-13-14-15-16-17-18-19-20-21-22-23-24-26-27-28-30-32mm | 5,8 |

| Especificaciones técnicas / Technical specification / Détails techniques | |
|--|-----------|
| Carraca / Ratchet / Cliquet | 250mm |
| Mango corredizo en T / Sliding T handle / Poigne coulissante | |
| Berbiqui / Speeder handle / Vilebrequin | 390mm |
| Alargadera / Extension / Rallonge | 125-250mm |
| Articulacion universal / Universal Joint / Cardan Universel | 75mm |
| Punta plana con vaso / Flat bit socket / Embout fente á douille | 13x2mm |



NEW

24 ANTICHISPA / NON-SPARKING / ANTI-DEFLAGRANT / FUNKENFREI ANTISCINTILLA / VONKVRIJE / ANTI-DEFLAGRANTE



SET

| COD | | PCS. | + | ○ | Kg |
|-------|---------|------|------|---|-----|
| Cu-Be | Al-Bron | | | | |
| 74273 | 74274 | 31 | 1/2" | 8-9-10-11-12-13-14-15-16-17 18-19-20-21-22-23-24-26 27-28-30-32mm | 6,4 |

| Especificaciones técnicas / Technical specification / Détails techniques | |
|--|-----------|
| Carraca / Ratchet / Cliquet | 250mm |
| Mango corredizo en T / Sliding T handle / Poigne coulissante | 390mm |
| Berbiquí / Speeder handle / Vilebrequin | 125-250mm |
| Alargadera / Extension / Rallonge | 75mm |
| Articulación universal / Universal Joint / Cardan Universel | 230mm |
| Mango acodado / Offset handle / Manche contre coudé | 13x2mm |
| Punta plana con vaso / Flat bit socket / Embout fente á douille | 13/16" |
| Vaso para bujías / Spark plug socket / Douille á bougie | |



NEW

| COD | | PCS. | + | ○ | Kg |
|-------|---------|------|------|---------------------------------------|-----|
| Cu-Be | Al-Bron | | | | |
| 74275 | 74276 | 14 | 3/4" | 21-24-27-30-32-34-36-38 41-46-50mm | 8,3 |

| Especificaciones técnicas / Technical specification / Détails techniques | |
|--|-------|
| Carraca / Ratchet / Cliquet | 320mm |
| Mango corredizo en T / Sliding T handle / Poigne coulissante | 400mm |
| Alargadera / Extension / Rallonge | 200mm |



NEW

| COD | | PCS. | + | ○ | Kg |
|-------|---------|------|------|--|-----|
| Cu-Be | Al-Bron | | | | |
| 74277 | 74278 | 20 | 3/4" | 21-22-23-24-26-27-28-29-30-31- 32-34-36-38-41-46-50mm | 8,3 |

| Especificaciones técnicas / Technical specification / Détails techniques | |
|--|-------|
| Carraca / Ratchet / Cliquet | 400mm |
| Mango corredizo en T / Sliding T handle / Poigne coulissante | 200mm |
| Alargadera / Extension / Rallonge | |



NEW

| COD | | PCS. | + | ○ | Kg |
|-------|---------|------|----|--|------|
| Cu-Be | Al-Bron | | | | |
| 74279 | 74280 | 18 | 1" | 30-31-32-34-36-38-41-46-50-55- 60-65-70-75-80mm | 18,5 |

| Especificaciones técnicas / Technical specification / Détails techniques | |
|--|-------|
| Mango corredizo en T / Sliding T handle / Poigne coulissante | 400mm |
| Alargadera / Extension / Rallonge | 200mm |
| Articulación flexible / Flexible joint / Articulation universelle | 120mm |



NEW

Cu-Be cobre berilio / beryllium copper / cuivre beryllium / Kupfer Beryllium / koper beryllium / rame-berillio
Al-Bron aluminio bronce / aluminium bronze / alliage aluminium-bronze / Aluminium Bronze / aluminium brons / aluminio bronz

**LLAVES DE VASO DE IMPACTO / IMPACT SOCKET WRENCHES / DOUILLES A CHOC /
IMPACT STECKSCHLÜSSEL EINSÄTZE / BUSSOLA AD IMPULSI / SLAGDOPSLEUTELS /
CHAVES DE CAIXA DE IMPACTO**

3/4"

| COD | | | | |
|-------|---------|----|----|------|
| Cu-Be | Al-Bron | | | |
| 72314 | 72315 | 24 | 55 | 350 |
| 72316 | 72317 | 27 | 55 | 380 |
| 72318 | 72319 | 30 | 60 | 500 |
| 72320 | 72321 | 32 | 60 | 530 |
| 72322 | 72323 | 36 | 60 | 560 |
| 72324 | 72325 | 41 | 65 | 780 |
| 72326 | 72327 | 46 | 65 | 900 |
| 72328 | 72329 | 50 | 70 | 1100 |

1"

| COD | | | | |
|-------|---------|----|----|------|
| Cu-Be | Al-Bron | | | |
| 72330 | 72331 | 19 | 60 | 650 |
| 72332 | 72333 | 21 | 60 | 670 |
| 72334 | 72335 | 22 | 60 | 680 |
| 72336 | 72337 | 24 | 60 | 690 |
| 72338 | 72339 | 26 | 60 | |
| 72340 | 72341 | 27 | 60 | 700 |
| 72342 | 72343 | 29 | 60 | 720 |
| 72344 | 72345 | 30 | 60 | 750 |
| 72346 | 72347 | 32 | 60 | |
| 72348 | 72349 | 34 | 70 | 780 |
| 72350 | 72351 | 35 | 70 | 850 |
| 72352 | 72353 | 36 | 70 | 870 |
| 72354 | 72355 | 38 | 70 | 890 |
| 72356 | 72357 | 41 | 70 | 920 |
| 72358 | 72359 | 46 | 80 | 1200 |
| 72360 | 72361 | 50 | 80 | 1500 |
| 72362 | 72363 | 52 | 90 | 1700 |
| 72364 | 72365 | 55 | 90 | 1800 |
| 72366 | 72367 | 58 | 90 | 1900 |
| 72368 | 72369 | 60 | 90 | 2000 |
| 72370 | 72371 | 65 | 90 | 2300 |
| 72372 | 72373 | 70 | 90 | 2700 |
| 72374 | 72375 | 75 | 90 | 3000 |
| 72376 | 72377 | 80 | 90 | 3300 |



1.3/16"

| COD | | | | |
|-------|---------|----|----|------|
| Cu-Be | Al-Bron | | | |
| 72378 | 72379 | 50 | 90 | 1800 |
| 72380 | 72381 | 52 | 90 | 1900 |
| 72382 | 72383 | 55 | 90 | 2000 |
| 72384 | 72385 | 58 | 90 | 2100 |
| 72386 | 72387 | 60 | 90 | |
| 72388 | 72389 | 65 | 90 | 2400 |
| 72390 | 72391 | 70 | 90 | 2600 |
| 72392 | 72393 | 75 | 90 | 3000 |
| 72394 | 72395 | 80 | 90 | 3400 |

PASADOR DE SEGURIDAD / SECURITY PIN / GOUPILLE DE SECURITE / SICHERUNGSSTIFT / COPPIGLIA / VEILIGHEIDSPIN
PINO DE SEGURANÇA

| COD | | | | Ø x L(mm) | | |
|-------|---------|---------|--|-----------|------|----|
| Cu-Be | Al-Bron | | | | | |
| 73621 | 73622 | 3-4" | | 24-30mm | 6x30 | 10 |
| 73623 | 73624 | | | 32-50mm | 6x40 | |
| 73625 | 73626 | 1" | | 19-41mm | 6x50 | 15 |
| 73627 | 73628 | | | 46-80mm | 6x60 | 20 |
| 73629 | 73630 | 1.3/16" | | 50-80mm | 6x65 | 25 |



LLAVES ESPECIALES / SPECIAL WRENCHES / CLÉS SPÉCIALES / SPEZIELL ZANGEN CHIAVE SPECIALE / SPECIALE SLEUTELS / CHAVES ESPECIAIS

LLAVE EN "C" / C WRENCH / CLÉ EN C / C SCHLÜSSEL / CHIAVE A C / C SLEUTEL / CHAVE EM C

| COD | | | | |
|-------|---------|-----|----|------|
| Cu-Be | Al-Bron | | | |
| 72418 | 72419 | | | |
| | | 450 | 40 | 1100 |



LLAVE EN "C" DOBLE / DOUBLE C WRENCH / CLÉ EN DOUBLE C / DOPPEL C SCHLÜSSEL / CHAIVE DOPPIA A C / DUBBELE C SLEUTEL / CHAVE EM C DUPLA

| COD | | | | | |
|-------|---------|-----|----|----|-----|
| Cu-Be | Al-Bron | | | | |
| 72420 | 72421 | | | | |
| | | 200 | 20 | 15 | 380 |



GANCHO GIRADOR DE VÁLVULAS / VALVE WHEEL HOOK / FIXATION GIRATOIRE DE VALVE / VENTILHAKEN
GANCIO GIREVOLE PER VALVOLE / VENTIELSLEUTEL / GANCHO DE RODA VÁLVULAS

| COD | | | | |
|-------|---------|-----|----|------|
| Cu-Be | Al-Bron | | | |
| 72422 | 72423 | | | |
| | | 200 | 30 | 250 |
| 72424 | 72425 | | | |
| | | 300 | 32 | 500 |
| 72426 | 72427 | | | |
| | | 250 | 35 | 350 |
| 72428 | 72429 | | | |
| | | 300 | 40 | 450 |
| 72430 | 72431 | | | |
| | | 350 | 45 | 570 |
| 72432 | 72433 | | | |
| | | 375 | 48 | 600 |
| 72434 | 72435 | | | |
| | | 400 | 50 | 650 |
| 72436 | 72437 | | | |
| | | 450 | 55 | 900 |
| 72438 | 72439 | | | |
| | | 500 | 60 | 1150 |
| 72440 | 72441 | | | |
| | | 550 | 65 | 1300 |
| 72442 | 72443 | | | |
| | | 600 | 70 | 1400 |
| 72444 | 72445 | | | |
| | | 650 | 75 | 1600 |
| 72446 | 72447 | | | |
| | | 700 | 80 | 1700 |
| 72448 | 72449 | | | |
| | | 750 | 85 | 2100 |
| 72450 | 72451 | | | |
| | | 800 | 90 | 2200 |





LLAVE DE VALVULA LARGA / LONG VALVE SPANNER / CLE POUR LONGUES VALVES / LANGER VENTIL-SCHLÜSSEL / LANBE MOERSLEUTEL VOOR VENTIEL / CHAVE LARGA PER VALVOLE / CHAVE DE VALVULA LONGA



| COD | | | | | |
|-------|---------|--------|------|-----|------|
| Cu-Be | Al-Bron | Øx | Øy | | |
| 71432 | 71435 | | | | |
| | | 3-7" | 18mm | 215 | 400 |
| 71433 | 71436 | | | | |
| | | 8-15" | 24mm | 400 | 900 |
| 71434 | 71437 | | | | |
| | | 16-20" | 30mm | 490 | 1400 |
| 71441 | 71445 | | | 800 | 6400 |



LLAVE TAPONADORA / BUNG WRENCH / CLE OUVRE-BIDONS / PFROPFEN-SCHLÜSSEL / CHIAVE APRIFUSTI
STOP MOERSLEUTEL / CHAVE ABRE BIDÕES



| COD | |  |  |
|-------|---------|---|---|
| Cu-Be | Al-Bron | | |
| 71446 | 71447 | 300 | 800 |

 LLAVE TAPONADORA UNIVERSAL / MUTI-HEAD BUNG WRENCH / CLE UNIVERSELLE Á BOUCHON / MULTI-HEAD
FASSSCHLÜSSEL / CHIAVE A TAPPO UNIVERSALE / MULTI KOP DRUMSLEUTEL / CHAVE DE BUJÕES UNIVERSAL



| COD | |  |  |
|-------|---------|---|---|
| Cu-Be | Al-Bron | | |
| 72452 | 72453 | 385 | 1200 |





ABREBIDONES / DRUM OPENER / OUVRES BIDONS / FASSÖFFNER / APRITOIO A TAMBURO / VATOPENER / ABRE BIDONS

| COD | |  |  |  |
|-------|---------|---|---|---|
| Cu-Be | Al-Bron | | | |
| 74282 | - | 485 | 3,2 | 1 |



 ABRIDOR DE TONELES DE CARBURO / CARBIDE DRUM OPENER / OUVREUR DE BIDON DE CARBURE / KARBID FASSÖFFNER
APRITOIO A TAMBURO DEL CARBURO / CARBID VATOPENER / CHAVE DE CARBURO PARA ABRIR TAMBORES

| COD | |  |  |
|-------|---------|---|---|
| Cu-Be | Al-Bron | | |
| 72169 | 72170 | 280 | 625 |

 LLAVE DE GANCHO / HOOK SPANNER / CLE D'ACCROCHE / ECKZANGE / HOEKSLEUTEL / CHIAVE A SETTORE
CHAVE DE GANCHO



| COD | | CAP |  |  |
|-------|---------|-----------|---|---|
| Cu-Be | Al-Bron | | | |
| 71392 | 71409 | 12 - 14 | 105 | 40 |
| 71393 | 71410 | 16 - 20 | 108 | 50 |
| 71394 | 71411 | 25 - 28 | 130 | 80 |
| 71395 | 71412 | 30 - 32 | 168 | 100 |
| 71396 | 71413 | 34 - 36 | | |
| 71397 | 71414 | 40 - 42 | 170 | 150 |
| 71398 | 71415 | 45 - 50 | | |
| 71399 | 71416 | 52 - 55 | 205 | 200 |
| 71400 | 71417 | 58 - 62 | | |
| 71401 | 71418 | 68 - 75 | 255 | 500 |
| 71402 | 71419 | 80 - 90 | | |
| 71403 | 71420 | 90 - 100 | 305 | 700 |
| 71404 | 71421 | 95 - 100 | | |
| 71405 | 71422 | 100 - 110 | 330 | 800 |
| 71406 | 71423 | 110 - 115 | | |
| 71407 | 71424 | 120 - 130 | 340 | 900 |
| 71408 | 71425 | 135 - 145 | | |

 LLAVE DE GANCHO ARTICULADA / ADJUSTABLE HOOK SPANNER / CLE D'ACCROCHE ARTICULEE / ZANGE MIT VERSTELLBARE
BACKE / TANG MET VERSTELBARE HAAK / CHIAVE A SETTORE REGOLABILE / CHAVE DE GANCHO ARTICULADA



| COD | | CAP |  |  |
|-------|---------|---------|---|---|
| Cu-Be | Al-Bron | | | |
| 71426 | 71429 | 32-75 | 205 | 200 |
| 71427 | 71430 | 50-120 | 285 | 500 |
| 71428 | 71431 | 115-170 | 310 | |



HERRAMIENTA PARA TUBO / PIPE TOOLS / OUTILLAGE TUBE / ROHR WERKZEUGE
FERRAMENTI PER TUBI / PIJPGEREEDSCHAP / FERRAMENTA PARA TUBOS
LLAVE HEAVY DUTY / HEAVY DUTY PIPE WRENCH / CLE SERRE-TUBES H.D. / EINHAND-ROHRZANGEN
GIRATUBI MODELLO AMERICANO PESANTE / VERSTERKTE PIJPTANG / CHAVE HEAVY DUTY

| COD | |  |  |  |
|-------|---------|---|---|---|
| Cu-Be | Al-Bron | | | |
| 70121 | 71458 | 8" | 1" | 0,35 |
| 70122 | 71459 | 10" | 1.1/2" | 0,83 |
| 70123 | 71460 | 12" | 2" | 1,3 |
| 70124 | 71461 | 14" | 2" | 1,7 |
| 70125 | 71462 | 18" | 2.1/2" | 2,6 |
| 70126 | 71463 | 24" | 3" | 4,5 |
| 70127 | 71464 | 36" | 5" | 8,8 |
| 70128 | 71465 | 48" | 6" | 15,8 |





LLAVE SUECA 45° / SWEDISH PIPE WRENCH 45° / SERRE-TUBES SUEDOISE 45° / EKROHRZANGE 45°
GIRATUBI MOD. SUEDESE 45° / PIJPTANG ZWEEDS MODEL 45° / CHAVE SUECA 45°

| COD | |  |  |  |
|-------|---------|---|---|---|
| Cu-Be | Al-Bron | | | |
| 70129 | 71466 | 1.1/2" | 420 | 1,4 |
| 70130 | 71467 | 2" | 560 | 2,5 |





LLAVE SPUD / SPUD PIPE WRENCH / CLE SPUD / VERSTELLBARE ROHRZANGE / GIRATUBI MODELLO SPUD
VERSTELLBARE PIJPTANG / CHAVE PARA TUBO SPUD

| COD | |  |  |  |
|-------|---------|---|---|---|
| Cu-Be | Al-Bron | | | |
| 71822 | 71823 | 12" | 2.5/8" | 1,2 |





LLAVE DE CORREA / STRAP WRENCH / CLE A SANGLE / GURTROHRZANGE / GIRATUBI A NASTRO / BANDTANG
CHAVE DE CORREIA

| COD | |  |  |  |
|-------|---------|---|---|---|
| Cu-Be | Al-Bron | | | |
| 73906 | 73907 | 300 | 3" | 800 |

NEW
LLAVE DE CADENA / CHAIN PIPE WRENCH / CLE A CHAINE / KETTEN-ROHRZANGE / CHIAVE DE CATENA / KETTINGTANG
CHAVE CORRENTE

| COD | |  |  |  |
|-------|---------|---|---|---|
| Cu-Be | Al-Bron | | | |
| 72976 | 72977 | 4" | 600 | 3,8 |
| 72978 | 72979 | 6" | 600 | 4,2 |
| 72980 | 72981 | 8" | 900 | 8,5 |
| 72982 | 72983 | 12" | 900 | 9,5 |

NEW

| COD | |  |  |  |
|-------|---------|---|---|---|
| Cu-Be | Al-Bron | | | |
| 70131 | 71468 | 2" | 600 | 2,2 |
| 70132 | 71469 | 4" | 600 | 2,8 |
| 70133 | 71470 | 6" | 600 | 3,5 |





CORTATUBOS DE ACERO / STEEL PIPE CUTTER / COUPE-TUBES ACIER / ROHRABSCHNEIDER / TAGLIATUBI PER FERRO
BUIZENSNIJDER / CORTA TUBOS AÇO

| COD | |  |  |  |  |
|-------|---------|---|---|---|---|
| Cu-Be | Al-Bron | | | | |
| 70134 | 71471 | 2" | 380 | 60 | 2,4 |





TORNILLO DE BANCO PARALELO / PARALLEL BENCH VICE / ETAU A MORS PARALLELES / PARALLELSCHRAUBSTÖCKE
MORSA DA BANCO PARALLELA / BANKSCHROEF MET PARALLELE BEKKEN-VAST MODEL / TORNO DE BANCADA PARALELO

| COD | |  |  |  |
|-------|---------|---|---|--|
| Cu-Be | Al-Bron | | | |
| 70482 | 71636 | 4" | 100 | 15 |
| 70483 | 71637 | 5" | 140 | 17,7 |
| 70486 | 72191 | 6" | | 20 |
| 70487 | 72192 | 7" | 200 | 25 |



PRENSA / CLAMP / PRESSE / KNEBEL / MORSETTO / BARCLAMP / PRENSA

| COD | |  | X | Y |  |
|-------|---------|---|-----|-----|---|
| Cu-Be | Al-Bron | | | | |
| 72478 | 72479 | 210 | 60 | 36 | 1200 |
| 72480 | 72481 | 250 | 80 | 36 | 1400 |
| 72482 | 72483 | 290 | 100 | 36 | 1600 |
| 72484 | 72485 | 340 | 150 | 50 | 2000 |
| 73418 | 73425 | 400 | 250 | 150 | 4900 |



SARGENTOS / CLAMPS / SERRE-JOINTS / ZWINGEN / MORSETTI SERRAGIUNTI / KLEMMEN / GRAMPOS
MOD. F



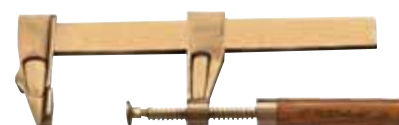

| COD | | CAP (mm) |  |
|-------|---------|----------|---|
| Cu-Be | Al-Bron | | |
| 74250 | 74251 | 400 | 2200 |



NEW

DESTORNILLADORES / SCREWDRIVERS / TOURNEVIS / SCHRAUBENDREHER
CACCIAVITI / SCHROEVENDRAAIER / CHAVES DE FENDA

MECANICO / SLOTTED / MECANICIEN / WERSTATT / PER MECCANICI / SCHROEVENDAAIER VOOR SLEUF SCHROEVEN / MECÂNICO

| COD | |  |  |  |  |
|-------|---------|---|---|---|--|
| Cu-Be | Al-Bron | | | | |
| 72258 | 72279 | 50 | 3 | 82 | 35 |
| 72259 | 72280 | | 4,5 | | 43 |
| 72260 | 72281 | | 3 | | 35 |
| 72261 | 72282 | 75 | 4 | 103 | 45 |
| 72262 | 72283 | | 5 | | 70 |
| 72263 | 72284 | | 4 | | 45 |
| 72264 | 72285 | 100 | 5 | 103 | 75 |
| 72265 | 72286 | | | | 85 |
| 72266 | 72287 | | 6 | | 100 |
| 72267 | 72288 | 150 | 7 | 112 | 110 |
| 72268 | 72289 | | | | 125 |
| 72269 | 72290 | | 8 | | 140 |
| 72270 | 72291 | 200 | | | 165 |
| 72271 | 72292 | 250 | 9 | | 185 |
| 72272 | 72293 | 200 | 10 | | 260 |
| 72273 | 72294 | 300 | | 235 | |
| 72274 | 72295 | 250 | | | 245 |
| 72275 | 72296 | 300 | 11 | | 290 |
| 72276 | 72297 | 350 | | 320 | |
| 72277 | 72298 | 400 | 12 | 150 | 400 |
| 72278 | 72299 | 450 | 13 | | 480 |



ELECTRICISTA / ELECTRICIEN / ELEKTRIKER / PER ELETTRICISTI / SCHROEVENDRAAIER VOOR SLEUFSCHROEVEN
MODEL ELEKTRICIEN

| COD | | | | | |
|-------|---------|-----|----|-----|-----|
| Cu-Be | Al-Bron | | | | |
| 71581 | 71588 | 50 | 3 | | 50 |
| 71582 | 71589 | 100 | 4 | 75 | 70 |
| 71583 | 71590 | 150 | | | 80 |
| 72306 | 72308 | 100 | 5 | | 100 |
| 72307 | 72309 | 200 | | | 200 |
| 71584 | 71591 | 100 | 6 | 95 | 100 |
| 71585 | 71592 | 150 | 8 | 105 | 200 |
| 71586 | 71593 | 200 | 10 | | |
| 71587 | 71594 | 300 | | | 300 |



PHILIPS

| COD | | | | | |
|-------|---------|------|-----|-----|-----|
| Cu-Be | Al-Bron | | | | |
| 72909 | 72910 | PH-0 | 60 | 75 | 40 |
| 71595 | 71599 | PH-1 | 80 | | 50 |
| 71596 | 71600 | PH-2 | 100 | 95 | 70 |
| 71597 | 71601 | PH-3 | 150 | | 80 |
| 71598 | 71602 | PH-4 | 200 | 105 | 100 |



DE VASO HEXAGONAL / HEXAGONAL SOCKET / DOUILLE HEXAGONALE / SCHRAUBENDREHER EINSATZ HEX
BUSSOLE ESAGONALI / DOPSLEUTELINZET HEX / CHAVE DE CAIXA HEXAGONAL

| COD | | | | | |
|-------|---------|-----|-----|-----|-----|
| Cu-Be | Al-Bron | HEX | | | |
| 73879 | 73880 | 6 | 90 | 100 | 85 |
| 73881 | 73882 | 8 | 100 | 110 | 100 |
| 73883 | 73884 | 10 | 110 | | 140 |
| 73885 | 73886 | 13 | 120 | 120 | 180 |
| 73887 | 73888 | 16 | | | 220 |
| 73889 | 73890 | 17 | | | 230 |



DESTORNILLADOR ACODADO / OFFSET SCREWDRIVER / TOURNEVIS CONTRE COUDÉ / GEKRÖPFTE SCHRAUBENDREHER
CACCIAVITE DOPPIO / GEBOGEN SCHROEVENDRAAIER / CHAVE DE FENDAS EM ÂNGULO

| COD | | | | | |
|-------|---------|-----|----|--|-----|
| Cu-Be | Al-Bron | | | | |
| 72462 | 72463 | 72 | 6 | | 25 |
| 72464 | 72465 | 125 | 8 | | 50 |
| 72466 | 72467 | 196 | 10 | | 125 |



1000V

| COD | | | | |
|-------|---------|-------|--|----|
| Cu-Be | Al-Bron | | | |
| 72225 | 72224 | PH-0 | | 50 |
| 72227 | 72226 | 4X100 | | 60 |



1.000V
IEC 900 resp.
DIN EN 60 900

**PALAS Y RASTRILLOS / SHOVELS AND RAKES / PELLES ET RACLETTES / SCHAUFEL
UND RECHEN / PALE E RASTRELLI / SCHOPPEN EN HARKEN / PÁS E ANSINHOS**

| COD | | L mm | A mm | B mm | SP |
|-------|---------|---------|---------|---------|------|
| Cu-Be | Al-Bron | | | | |
| 71615 | 71616 | 1350 | 240 | 290 | 1500 |

**PALA PUNTA / ROUND POINT SHOVEL / PELLE EN POINTE / SCHWANENHALSSCHAUFEL / PALA A PUNTA TONDA /
SCHEP MET ZWANEHALS / PA DE BICO**

| COD | | L mm | A mm | B mm | SP |
|-------|---------|---------|---------|---------|------|
| Cu-Be | Al-Bron | | | | |
| 71617 | 71618 | 1350 | 240 | 290 | 1500 |

**PALA DE CAVAR / EDING SPADE / PELLE BÊCHE / SCHAUFEL VIERECKING / PALA PER SCAVARE / SCHEP VIERKANT
PA DE VALAR**

| COD | | L mm | A mm | B mm | SP |
|-------|---------|---------|---------|---------|------|
| Cu-Be | Al-Bron | | | | |
| 71619 | 71620 | 1120 | 280 | 180 | 1500 |

PALETA / BRICKLAYER / SPATULE / MAUERKELLE / PALETTA / STUKADOORSGEREEDSCHAP / COLHER

| COD | | L mm | A mm | B mm | SP |
|-------|---------|---------|---------|---------|-----|
| Cu-Be | Al-Bron | | | | |
| 73772 | 73773 | 335 | 215 | 130 | 650 |

AZADA / HOE / HOUE / HAUE / ZAPPA / TREKSCHOFFEL / ENXADA

| COD | | L mm | SP |
|-------|---------|---------|------|
| Cu-Be | Al-Bron | | |
| 74253 | 74254 | 130x130 | 1000 |
| 74255 | 74256 | 200x200 | 1600 |

**HORQUILLA 3 PUNTAS / 3 PRONG FORK / FOURCHE À TROIS POINTES / SPATENGABEL MIT 2 ZINKEN / FORCA A 3 PUNTE
RIEKVORK / FORQUILHA 3 PONTAS**

| COD | | L mm | SP |
|-------|---------|---------|------|
| Cu-Be | Al-Bron | | |
| 74231 | 74232 | 200 | 1500 |

**HORQUILLA 4 PUNTAS / 4 PRONG FORK / FOURCHE À QUATRE POINTES / SPATENGABEL MIT 4 ZINKEN / FORCA A 4 PUNTE
RIEKVORK / FORQUILHA 4 PONTAS**

| COD | | L mm | SP |
|-------|---------|---------|------|
| Cu-Be | Al-Bron | | |
| 74234 | 74235 | 320 | 2000 |

**RASTRILLO LIMPIADOR DE OXIDO / RUST CLEANING RAKE / RACLETTE POUR NETTOYAGE DE L'OXIDE / RECHEN F/ROST
RASTRELLO PER PULIRE L'OSSIDO / ROEST SCHOONMAKENDE HARK / ANSINHO LIMPADOR DE OXIDO**

| COD | | L mm | SP |
|-------|---------|---------|-----|
| Cu-Be | Al-Bron | | |
| 74237 | 74238 | 100x350 | 900 |

RASTRILLO / RAKE / RACLETTE / RECHEN / RASTRELLO / HARK / ANSINHO

| COD | | L mm | SP |
|-------|---------|---------|------|
| Cu-Be | Al-Bron | | |
| 74258 | 74259 | 350x100 | 1300 |
| 74260 | 74261 | 450x120 | 1500 |

Cu-Be cobre berilio / beryllium copper / cuivre beryllium / Kupfer Beryllium / koper beryllium / rame-berillio
Al-Bron aluminio bronce / aluminium bronze / alliage aluminium-bronze / Aluminium Bronze / aluminium brons / aluminio bronz

CORTE / CUTTING / OUTILS COUPANTS / SCHNEIDWERKZEUG / ARCHETTI / SNIJWERKTUIGEN

CORTAVARILLAS / BOLT CUTTERS / COUPE-BOULONS / BOLZENSCHNEIDER / TAGLIABULLONI / BOUTENSCHAREN / CORTA VARAO

| COD | | | |
|-------|---------|-----|------|
| Cu-Be | Al-Bron | | |
| 73415 | 73423 | 24" | 3000 |

CIZALLA DE PASO LIBRE A LA DERECHA / RIGHT CUT NIPPER SHEAR / CISAILLE A PASSAGE DROIT LIBRE
SCHNEIDSCHERE RECHTS / CESCOIA TAGLIO DESTRO / KNIPSCHAAR RECHTS / TESOURA DE PASSAGEM LIVRE A DIREITA

| COD | | | |
|-------|---------|-----|-----|
| Cu-Be | Al-Bron | | |
| 70528 | 70545 | 275 | 600 |



TIJERAS / SCISSORS / CISEAUX / SCHERE / CESCOIE / SCHAAR / TESOIRA

| COD | | | |
|-------|---------|-----|-----|
| Cu-Be | Al-Bron | | |
| 70529 | 70546 | 225 | 300 |



| COD | | | |
|-------|---------|-----|----|
| Cu-Be | Al-Bron | | |
| 72460 | 72461 | 150 | 90 |



| COD | | | |
|-------|---------|-----|-----|
| Cu-Be | Al-Bron | | |
| 73892 | 73893 | 290 | 220 |
| 73894 | 73895 | 360 | 850 |

TIJERAS DE HOJALATERO / TIN SNIPS / CISEAUX DE TOLIER / BLECHSCHEREN / BLIKSCHAREN / CESCOIA PER LATTONNIERI
TESOURAS DE CHAPA

| COD | | | |
|-------|---------|-----|-----|
| Cu-Be | Al-Bron | | |
| 72458 | 72459 | 300 | 450 |

ARCO DE SIERRA / HACK SAW / MONTURE DE SCIE A METAUX / METALLSÄGEN GEBOGEN / ARCHETTI / ZAAGBOGEN
ARCO DE SERRA

| COD | | | |
|-------|---------|-----|-----|
| Cu-Be | Al-Bron | | |
| 72220 | 72221 | 500 | 600 |

HOJAS PARA ARCO DE SIERRA / HACKSAW BLADES / LAMES DE SCIES / METALLSÄGEBLÄTTER / LAME PER ARCHETTI/
ZAAGBLADEN / FOLHA DE SERRA

| COD | | | |
|-------|---------|-----|----|
| Cu-Be | Al-Bron | | |
| 72223 | | 300 | 30 |



SIERRA MANUAL / HANDSAW / SCIE À MAIN / HANDSÄGE / ARCO MANUALE / HANDZAAG / SERROTE MANUAL

| COD | | | |
|-------|---------|-----|-----|
| Cu-Be | Al-Bron | | |
| 72468 | 72469 | 370 | 125 |





Cu-Be cobre berilio / beryllium copper / cuivre beryllium / Kupfer Beryllium / koper beryllium / rame-berillio

Al-Bron aluminio bronce / aluminium bronze / alliage aluminium-bronze / Aluminium Bronze / aluminium brons / aluminio bronz

ANTICHISPA / NON-SPARKING / ANTI-DEFLAGRANT / FUNKENFREI ANTISCINTILLA / VONKVRIJE / ANTI-DEFLAGRANTE



SERRUCHO / HANDSAW / SCIE ÉGOÏNE / HANDSÄGE / SEGHETTO / HANDZAAG / SERROTE

| COD | |  |  |
|-------|---------|---|---|
| Cu-Be | Al-Bron | | |
| 74228 | 74229 | 700 | 530 |





NEW

CUCHILLOS / KNIVES / COUTEAUX / MESSER / COLTELLI / MESSER / FACAS



| COD | |  |  |
|-------|---------|---|---|
| Cu-Be | Al-Bron | | |
| 71611 | 71612 | 30x200 | 70 |



| COD | |  |  |
|-------|---------|---|---|
| Cu-Be | Al-Bron | | |
| 71613 | 71614 | 250 | 90 |





NAVAJA DE ELECTRICISTA / ELECTRICIAN KNIFE / COUTEAU ELECTRICIEN / ELEKTRIKER MESSER / COLTELLO PER ELETTRICISTI / ELECTRICIENSMESS / NAVALHA DE ELECTRICISTA

| COD | |  |  |
|-------|---------|---|---|
| Cu-Be | Al-Bron | | |
| 73741 | 73742 | 70x180 | 180 |



NEW

BROCAS / TWIST DRIL / FORET ÉTAGER / BOHRER / PUNTE PER TRAPANO / SPIRAALBOOR / BROCAS



| COD | Cu-Be |  |  |  |
|-------|-------|---|---|---|
| 73632 | 6 | | | |
| 73633 | 7 | 120 | 35 | |
| 73634 | 8 | 140 | 55 | |
| 73635 | 9 | 160 | 80 | |
| 73636 | 10 | 180 | 110 | |
| 73637 | 11 | 200 | 150 | |
| 73638 | 12 | 220 | 200 | |
| 73639 | 13 | 240 | 250 | |
| 73640 | 14 | 260 | 320 | |
| 73641 | 15 | 280 | 400 | |
| 73642 | 16 | 300 | 470 | |
| 73643 | 17 | 320 | 540 | |
| 73644 | 18 | 320 | 650 | |
| 73645 | 19 | 320 | 720 | |
| 73646 | 20 | 330 | 820 | |



NEW



LIMAS / FILES / LIMES / FEILEN / LIMA / VIJLEN / LIMAS

LIMA PLANA / HAND FILE / LIME PLATE / HANDFEILE / LIMA PIATTA / HANDVIJL / LIMA PARALELA

| COD | |  |  |
|-------|---------|---|---|
| Cu-Be | Al-Bron | | |
| 71607 | 71609 | 200 | 350 |
| 71608 | 71610 | 300 | 740 |





LIMAS MEDIA CAÑA / HALF ROUND FILES / LIMES DEMI-RONDES / HALBRUND FEILEN / LIMA MEZZATONDA / HALFRONDE VIJLEN
LIMAS MEIA CANA

| COD | |  |  |
|-------|---------|---|---|
| Cu-Be | Al-Bron | | |
| 71603 | 71604 | 200 | 450 |



LIMA REDONDA / ROUND FILE / LIME RONDE / RUND FEILE / RONDE VIJL / LIME TONDE / LIMATÃO REDONDO

| COD | |  |  |
|-------|---------|---|---|
| Cu-Be | Al-Bron | | |
| 71605 | 71606 | 200 | 350 |

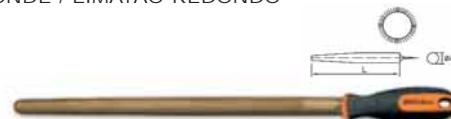



Cu-Be cobre berilio / beryllium copper / cuivre beryllium / Kupfer Beryllium / koper beryllium / rame-berillio



Al-Bron aluminio bronce / aluminium bronze / alliage aluminium-bronze / Aluminium Bronze / aluminium brons / aluminio bronz

MISCELANEA / MISCELLANEOUS / MELANGEE / VERSCHIEDENE / MISCELLANEA / DIVERSE
MISTURA



CINCEL / FLAT CHISEL / CISEAUX / MAURERMEISSEL / SCALPELLI / METSELAARSBEITEL / ESCOPRO

| COD | |  |  |
|-------|---------|---|---|
| Cu-Be | Al-Bron | | |
| 70447 | 71509 | 150x22 | 300 |
| 70448 | 71510 | 200x22 | 400 |
| 70449 | 71511 | 250x24 | 600 |
| 70450 | 71512 | 300x24 | 800 |
| 70451 | 71513 | 400x27 | 1000 |



CINCEL EN PUNTA / CROSS CUTTING CHISEL / BROCHE / DURCHSCHLAGMEISSEL / SCALPELLI A PUNTA / DOORSLAGBEITEL
PONTEIRO

| COD | |  |  |
|-------|---------|---|---|
| Cu-Be | Al-Bron | | |
| 73778 | 73779 | 140 | 270 |
| 73780 | 73781 | 200 | 450 |
| 73782 | 73783 | 300 | 800 |

CORTAFRIOS CILINDRICO / CYLINDRICAL CHISEL / NÉDANE CYLINDRIQUE / ZYLINDRISCHE MEIß EL / SCALPELLO CILINDRICO
TAGLIO A FREDDO / CILINDRISCHE BEITEL / ESCOPRO CILINDRICO



| COD | |  | Ø (mm) |  |
|-------|---------|---|--------|---|
| Cu-Be | Al-Bron | | | |
| 73788 | 73789 | 14x160 | 14 | 175 |
| 73790 | 73791 | 16x160 | 16 | 230 |
| 73792 | 73793 | 18x160 | 18 | 280 |
| 73794 | 73795 | 18x200 | 18 | 370 |
| 73796 | 73797 | 20x200 | 20 | 470 |
| 73798 | 73799 | 24x250 | 24 | 800 |
| 73800 | 73801 | 24x300 | 24 | 1000 |
| 73802 | 73803 | 25x300 | 25 | 1250 |
| 73804 | 73805 | 25x400 | 25 | 1400 |
| 73806 | 73807 | 25x500 | 25 | 1800 |
| 73808 | 73809 | 30x500 | 30 | 2650 |

CORTAFRIOS HEXAGONAL / HEXAGONAL CHISEL / BÉDANE HÉXAGONALE / HEX MEIß EL / SCALPELLO ESAGONALE
TAGLIO A FREDDO / HEX BEITEL / ESCOPRO HEXAGONAL

| COD | |  |  |  |
|-------|---------|---|---|---|
| Cu-Be | Al-Bron | | | |
| 73811 | 73812 | 12x150 | 10 | 100 |
| 73813 | 73814 | 16x200 | 14 | 250 |
| 73815 | 73816 | 18x160 | 16 | 260 |
| 73817 | 73818 | 16x250 | 14 | 320 |
| 73819 | 73820 | 19x300 | 17 | 700 |
| 73821 | 73822 | 19x350 | 17 | 900 |
| 73823 | 73824 | 24x600 | 22 | 1800 |
| 73825 | 73826 | 28x300 | 25 | 1100 |
| 73827 | 73828 | 35x500 | 30 | 2700 |



GRANETE / CENTRE PUNCH / CHASSE-CLOUS / KÖRNER / PUNTE DA CENTRO / DOORSLAG / PUNÇÃO DE BICO



| COD | |  |  |
|-------|---------|---|---|
| Cu-Be | Al-Bron | | |
| 71514 | 71516 | 100 | 60 |
| 71515 | 71517 | 150 | 80 |



Cu-Be cobre berilio / beryllium copper / cuivre beryllium / Kupfer Beryllium / koper beryllium / rame-berillio



Al-Bron aluminio bronce / aluminium bronze / alliage aluminium-bronze / Aluminium Bronze / aluminium brons / aluminio bronz

BOTADOR / DRIFT PIN BARREL & STRAIGHT / CHASSE RIVETS / DURCHSCHLÄGER / PUNZONE / DOORSLAG / PUNÇÃO

| COD | | |  |  |
|-------|---------|--------|---|---|
| Cu-Be | Al-Bron | mm | | |
| 70426 | 71472 | 2 | 150x10 | 60 |
| 70427 | 71473 | 3 | | |
| 70428 | 71474 | 4 | | |
| 70429 | 71475 | 5 | | |
| 70430 | 71476 | 6 | | |
| 70431 | 71477 | 7 | 150x12 | 70 |
| 70432 | 71478 | 8 | | |
| 70433 | 71479 | 9 | 150x14 | 200 |
| 70434 | 71480 | 10 | | |
| 70435 | 71481 | 11 | 150x16 | 300 |
| 70436 | 71482 | 12 | | |
| 70437 | 71483 | 13 | 150x18 | 400 |
| 70438 | 71484 | 14 | | |
| 70439 | 71485 | 15 | 200x20 | 500 |
| 70440 | 71486 | 16 | | |
| 70441 | 71487 | 17 | 200x22 | 800 |
| 70442 | 71488 | 18 | | |
| 70443 | 71489 | 19 | 250x24 | 900 |
| 70444 | 71490 | 20 | | |
| 70445 | 71491 | 21 | 250x26 | 950 |
| 70446 | 71492 | 22 | | |
| | | inch. | | |
| 73583 | 73572 | 7/8" | 250x26 | 1000 |
| 73584 | 73573 | 1" | | |
| 73585 | 73574 | 1.1/8" | | |
| 73586 | 73575 | 1.1/4" | | |
| 73587 | 73576 | 1.3/8" | | |
| 73588 | 73577 | 1.1/2" | | |
| 73589 | 73578 | 1.5/8" | | |
| 73590 | 73579 | 1.3/4" | | |
| 73591 | 73580 | 1.7/8 | | |



BOTADOR / PIN PUNCH / CHASSE-GOUPILLES / DURCHSCHLÄGER / PUNTE / DOORSLAG / PUNÇÃO

| COD | | |  |  |
|-------|---------|-----|---|---|
| Cu-Be | Al-Bron | mm | | |
| 71518 | 71527 | 1,4 | 110 | 50 |
| 71519 | 71528 | 1,8 | | |
| 71520 | 71529 | 2,4 | | |
| 71521 | 71530 | 2,8 | | |
| 71522 | 71531 | 3 | | |
| 71523 | 71532 | 4 | 120 | 60 |
| 71524 | 71533 | 5 | 130 | |
| 71525 | 71534 | 6 | 140 | |
| 71526 | 71535 | 8 | 150 | |
| | | | | |
| | | | | 100 |
| | | | | 160 |



PUNTERO / DIAMOND POINT CHISEL / BURIN / KÖRNER / PUNTE / DOORSLAG / PUNÇÃO

| COD | | |  |  |
|-------|---------|-----|---|---|
| Cu-Be | Al-Bron | mm | | |
| 71544 | 71548 | 200 | 16 | 300 |
| 71545 | 71549 | 250 | 17 | 500 |
| 71546 | 71550 | 300 | 19 | 600 |
| 71547 | 71551 | 400 | 20 | 1000 |

 PUNTERO ESPECIAL / CAULKING TOOL / BURIN SPECIAL / KÖRNER LANG / PUNTE SPECIALI / LANGE DOORSLAG
PUNÇÃO ESPECIAL

| COD | | |  |
|-------|---------|---------|---|
| Cu-Be | Al-Bron | mm | Kg |
| 71552 | 71557 | 1000-32 | 6,5 |
| 71553 | 71558 | 1200-36 | 9,5 |
| 71554 | 71559 | 1500-36 | 13,5 |
| 71555 | 71560 | 1000-50 | 16 |
| 71556 | 71561 | 1200-50 | 18 |



CUÑA / WEDGE / COIN / KEIL / CUNEO / WIG / CUNHA

| COD | | | | | |
|-------|---------|-----|------|------|------|
| Cu-Be | Al-Bron | | y mm | x mm | g |
| 70452 | 71493 | 100 | 50 | 10-0 | 200 |
| 70453 | 71494 | 135 | 50 | 18-0 | 500 |
| 70454 | 71495 | 150 | 25 | 8-0 | 100 |
| 70455 | 71496 | | | 13-0 | 200 |
| 70456 | 71497 | 150 | 40 | 8-0 | 400 |
| 70457 | 71498 | 150 | 50 | 13-0 | 400 |
| 70458 | 71499 | 180 | 13 | 6-0 | 300 |
| 70459 | 71500 | 180 | 32 | 13-0 | |
| 70460 | 71501 | 180 | 50 | 19-0 | 700 |
| 70461 | 71502 | 200 | 20 | 30-0 | 500 |
| 70462 | 71503 | 200 | 30 | | 800 |
| 70463 | 71504 | 200 | 40 | 40-0 | 1300 |
| 70464 | 71505 | 200 | 50 | 12-0 | 500 |
| 70465 | 71506 | 230 | 40 | 20-0 | 800 |
| 70466 | 71507 | 250 | | 30-0 | 1300 |
| 70467 | 71508 | 300 | 50 | 40-0 | 2500 |



PALANCA / PINCHBAR / PINCE A TALON / BRECHSTANGE / LEVA / BREEKIJZER / AVALANCA

| COD | | | |
|-------|---------|---------|-----|
| Cu-Be | Al-Bron | | |
| 70468 | 71570 | 19x500 | 1,3 |
| 70469 | 71571 | 23x800 | 2,9 |
| 70470 | 71572 | 28x1000 | 4,4 |

BARRA DE DESENCOFRAR / WRECKING BAR / PINCE MONSEIGNEUR / BRECHEISEN / APRICASSE CON LEVA CHIODI
BREEKIJZER / PE DE CABRA

| COD | | | |
|-------|---------|--------|-----|
| Cu-Be | Al-Bron | | |
| 71573 | 71577 | 16x460 | 1,3 |
| 71574 | 71578 | 19x600 | 2,4 |
| 71575 | 71579 | 19x760 | 3 |
| 71576 | 71580 | 19x900 | 3,3 |



PALANCA / PINCHBAR / PINCE A TALON / BRECHSTANGE / LEVA / BREEKIJZER / AVALANCA

| COD | | | | |
|-------|---------|--------|----|-----|
| Cu-Be | Al-Bron | Ø (mm) | | |
| 73833 | 73834 | 500 | 15 | 0,7 |
| 73835 | 73836 | | 19 | 1 |
| 73837 | 73838 | | 20 | 1,2 |
| 73839 | 73840 | | 25 | 1,8 |
| 73841 | 73842 | | 30 | 2,7 |
| 73843 | 73844 | 600 | 25 | 2,2 |
| 73845 | 73846 | | 30 | 3,3 |
| 73847 | 73848 | | 23 | 2,1 |
| 73849 | 73850 | 800 | 25 | 3 |
| 73851 | 73852 | | 30 | 4,3 |
| 73853 | 73854 | 850 | 30 | 4,6 |
| 73855 | 73856 | | 25 | 3,8 |
| 73857 | 73858 | 1000 | 28 | 4,6 |
| 73859 | 73860 | | 30 | 5,4 |
| 73861 | 73862 | | 25 | 4,6 |
| 73863 | 73864 | 1200 | 30 | 6,6 |
| 73865 | 73866 | | 30 | 8,4 |



Cu-Be cobre berilio / beryllium copper / cuivre beryllium / Kupfer Beryllium / koper beryllium / rame-berillio

Al-Bron aluminio bronce / aluminium bronze / alliage aluminium-bronze / Aluminium Bronze / aluminium brons / aluminio bronzo

ANTICHISPA / NON-SPARKING / ANTI-DEFLAGRANT / FUNKENFREI ANTISCINTILLA / VONKVRIJE / ANTI-DEFLAGRANTE

HERRAMIENTA DE REMATAR / CAULKING TOOL / CLE DE FINITION / ABDICHTEN-WERKZEUG / UTENSILI DA SVENDERE / AFDICHTGEREEDSCHAP / FERRAMENTA DE CALAFETAR

| COD | | | X | H | |
|-------|---------|-----|----|---|-----|
| Cu-Be | Al-Bron | | | | |
| 72601 | 72602 | 200 | 20 | 5 | 450 |
| 72603 | 72604 | 250 | | 8 | 625 |

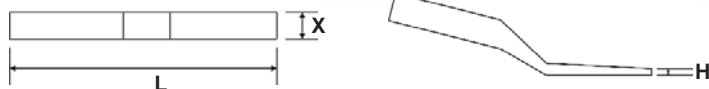

BARRA DE REMATAR / CAULKING TOOL / PINCE DE MONTEUR / STEMMWERKZEUG / BARRA SENZAFINE / WATERDICHTMAKEND GEREEDSCHAP / PE DE CALAFETAR

| COD | | | | |
|-------|---------|------|----|----|
| Cu-Be | Al-Bron | | | |
| 73830 | 73831 | 1200 | 50 | 16 |



CINCELES NEUMÁTICOS / PNEUMATIC CHISELS / BURINS PNEUMATIQUES / PNEUMATISCHE MEISSEL
SCALPELLO PNEUMATICO/ PNEUMATISCHE BEITEL / ESCOPROS PNEUMÁTICOS

| COD | | X | Y | Z | |
|-------|---------|----|-----|-----|------|
| Cu-Be | Al-Bron | | | | |
| 72583 | 72584 | 28 | 150 | 350 | 3200 |



| COD | | X | | Ø | |
|-------|---------|----|-----|----|-----|
| Cu-Be | Al-Bron | | | | |
| 72585 | 72586 | 10 | 125 | 12 | 120 |
| 72587 | 72588 | | 175 | | 170 |



| COD | | X | | Y | |
|-------|---------|----|-----|-----|--|
| Cu-Be | Al-Bron | | | | |
| 72589 | 72590 | 10 | 125 | 150 | |
| 72591 | 72592 | | 175 | 190 | |

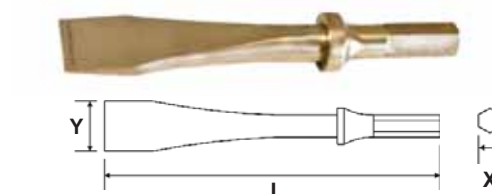

| COD | | X | | Y | |
|-------|---------|----|-----|-----|--|
| Cu-Be | Al-Bron | | | | |
| 72593 | 72594 | 10 | 125 | 150 | |
| 72595 | 72596 | | 175 | 190 | |

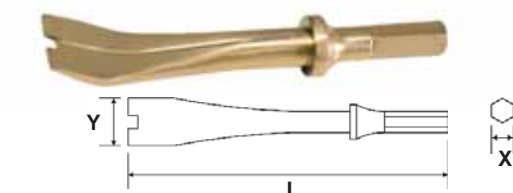

| COD | | X | | Y | |
|-------|---------|----|-----|-----|--|
| Cu-Be | Al-Bron | | | | |
| 72597 | 72598 | 10 | 125 | 150 | |
| 72599 | 72600 | | 175 | 190 | |

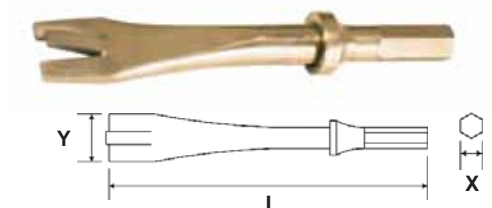

TRAZADOR / MARKING TOOL / TRACEUR / MARKIERUNGSWERKZEUG / TRACCIATORE / MARKEERGEREEDSCHAP / TRAÇADOR

| COD | | | Ø (mm) | |
|-------|---------|-----|--------|------|
| Cu-Be | Al-Bron | | | |
| 74217 | 74218 | 400 | 12 | 450 |
| 74219 | 74220 | 600 | 16 | 1000 |



| COD | | | Ø (mm) | |
|-------|---------|-----|--------|----|
| Cu-Be | Al-Bron | | | |
| 72216 | 72217 | 190 | 4 | 15 |
| 74222 | 74223 | 250 | 4 | 20 |



PUNZON / AWL / POINTEAU / AHLE / PUNZONI / ELS / PUNÇÃO

| COD | | | Ø (mm) | |
|-------|---------|---------|--------|----|
| Cu-Be | Al-Bron | | | |
| 74225 | 74226 | 100x200 | 3 | 50 |

GANCHOS AJUSTABLES PARA BIDONES / ADJUSTABLE BARREL HOOKS / CROCHETS AJUSTABLES POUR BIDONS
VERSTELBARE FASSHAKEN / GANCIO REGOLABILE PER BIDONI / VERSTELBARE VAT HAAK / GANCHOS AJUSTÁVEIS PARA BIDONS

| COD | | Ø MAX (mm) | CAP (Kg) | |
|-------|---------|------------|----------|------|
| Cu-Be | Al-Bron | | | |
| 74247 | 74248 | 1060 | 700 | 3200 |

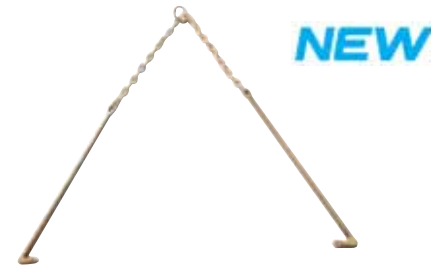
RASQUETA / LONG BLADE SCRAPER / LONGUE LAME / FLACHSCHABER / RASCHIETTO / SCHRAPER VOOR STEELMONTAGE
RASCADOR

| COD | | mm | |
|-------|---------|---------|-----|
| Cu-Be | Al-Bron | | |
| 71562 | 71566 | 60x185 | 1,2 |
| 71563 | 71567 | 100x225 | 1,5 |
| 71564 | 71568 | 150x180 | 2,6 |
| 71565 | 71569 | 125x225 | |



ESPATULA / SCRAPER / SPATULE / SPACHTEL / SPATOLA / SCHILDERMES / ESPATULA



| COD | | | |
|-------|---------|---------|-----|
| Cu-Be | Al-Bron | | |
| 70471 | 71621 | 25x200 | 50 |
| 70472 | 71622 | 30x200 | 60 |
| 70473 | 71623 | 40x200 | |
| 70474 | 71624 | 50x200 | 80 |
| 70475 | 71625 | 60x200 | 90 |
| 70476 | 71626 | 75x200 | 100 |
| 70477 | 71627 | 80x200 | |
| 70478 | 71628 | 100x200 | 130 |



Cu-Be cobre berilio / beryllium copper / cuivre beryllium / Kupfer Beryllium / koper beryllium / rame-berillio



Al-Bron aluminio bronce / aluminium bronze / alliage aluminium-bronze / Aluminium Bronze / aluminium brons / aluminio bronzo

RASPADOR / SCRAPER / RACLOIR / SCHABER / RASCHIETTO / SCHRAPER / RASPADOR



| COD | |  |  |
|-------|---------|---|---|
| Cu-Be | Al-Bron | | |
| 73759 | 73760 | 95x480 | 650 |



NEW



| COD | |  |  |
|-------|---------|---|---|
| Cu-Be | Al-Bron | | |
| 72155 | 72156 | 50x900 | 650 |



| COD | |  |  |
|-------|---------|---|---|
| Cu-Be | Al-Bron | | |
| 73744 | 73745 | 50x900 | 650 |



NEW



| COD | |  |  |
|-------|---------|---|---|
| Cu-Be | Al-Bron | | |
| 73750 | 73751 | 50x695 | 900 |
| 73752 | 73753 | 75x710 | 1100 |
| 73754 | 73755 | 100x710 | 1200 |
| 73756 | 73757 | 150x750 | 2000 |



NEW



| COD | |  |  |
|-------|---------|---|---|
| Cu-Be | Al-Bron | | |
| 72167 | 72168 | 40x270 | 350 |



| COD | |  |  |
|-------|---------|---|---|
| Cu-Be | Al-Bron | | |
| 73747 | 73749 | 48x300 | 400 |





NEW

| COD | |  |  |
|-------|---------|---|---|
| Cu-Be | Al-Bron | | |
| 73762 | 73763 | 75x600 | 650 |



NEW



RASPADOR CURVO / ARCHED SCRAPER / GRATTOIR COURBÉ / SPACHTEL FÜR GEBOGEN FLÄCHEN / RASPE CURVE
SCHRAPER VOOR GEBOGEN VLAKKEN / RASPADOR CURVO

| COD | |  |  |
|-------|---------|---|---|
| Cu-Be | Al-Bron | | |
| 73765 | 73766 | 50x190 | 400 |
| 73767 | 73768 | 100x210 | 650 |
| 73769 | 73770 | 150x220 | 800 |



NEW

RASPADOR PLANO / FLAT SCRAPER / RACLOIR PLATTE / FLACHSCHABER / RASCHIETTO PIATTO / VLAKKE SCHRAPER
RASPADOR PLANO

| COD | |  |  |
|-------|---------|---|---|
| Cu-Be | Al-Bron | | |
| 72157 | 72162 | 30x200 | 300 |
| 72158 | 72163 | 30x300 | 425 |
| 72159 | 72164 | 35x350 | 575 |
| 72160 | 72165 | 50x350 | 900 |
| 72161 | 72166 | 60x400 | 1400 |



RASQUETA TRIANGULAR / TRIANGULAR SCRAPER / RACLOIR TRIANGULAIRE / DREIECKIGER SPACHTEL / RASCHIETTO TRIANGOLARE / DROEHOEK SCRAPER / RASCADOR TRIANGULAR

| COD | | L | L ₁ | GP |
|-------|---------|-----|----------------|-----|
| Cu-Be | Al-Bron | | | |
| 73422 | 73399 | 360 | 255 | 250 |

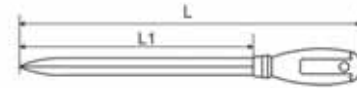

| COD | | L | GP |
|-------|---------|---------|------|
| Cu-Be | Al-Bron | | |
| 73775 | 73776 | 150x470 | 1000 |



PICO Y RASQUETA / SCRAPER PICK AND SCALER / PIQUE ET RACLETTE / REINIGUNGSWERKZEUG / PICCONE E RASCHIETTI REINIGUNGSCHRAPER / BICO E PÁ

| COD | | L | GP |
|-------|---------|--------|------|
| Cu-Be | Al-Bron | | |
| 73785 | 73786 | 75x450 | 1200 |



CUBO / BUCKET / CUBE / EIMER / SECCHIO / EMMER / BALDE

| COD | | Ø | L | GP |
|-------|--|-----|-----|------|
| Cu-Be | | | | |
| 72486 | | 270 | 250 | 1500 |



CUCHARA RECOGEDORA DE AZUCAR / SUGAR SCOOP / CUILLÈRE À SUCRE / SCHÖPFSCHAUFEL / RACCOGLITORE DI ZUCCHERI / CONCAAF SCHRAPER / COLHER PARA AÇUCAR

| COD | | L | GP |
|-------|--|-----|-----|
| Cu-Be | | | |
| 72487 | | 150 | 130 |
| 72488 | | 200 | 335 |
| 72489 | | 270 | 635 |



RECOGEDOR / DUSTPAN / PELLE / HANDSCHAUFEL / RACCOGLITORE / VULBLIK / RECIPIENTE

| COD | | L | GP |
|-------|--|-----|-----|
| Cu-Be | | | |
| 72490 | | 350 | 580 |



AGUJA / NEEDLE / AIGUILLE / NADEL / AGO / NAALD / AGULHA

| COD | | L | Ø (mm) | GP |
|-------|---------|-----|--------|-----|
| Cu-Be | Al-Bron | | | |
| 73868 | 73869 | 250 | 6 | 80 |
| 73870 | 73871 | 300 | 8 | 150 |
| 73872 | 73873 | 400 | 7 | 160 |
| 73874 | 73875 | 500 | 10 | 320 |



NEW

AGUJA / NEEDLE / AIGUILLE / NADEL / AGO / NAALD / AGULHA

| COD | | L (mm) | Ø (mm) | UF |
|-------|---------|--------|--------|----|
| Cu-Be | Al-Bron | | | |
| 73877 | - | 180 | 3 | 12 |

NEW

EMBUDO / FUNNEL / ENTONNOIR / TRICHTER / IMBUTO / TRECHTER / FUNIL

| COD | | Ø MAX (mm) | L (mm) | UF |
|-------|---------|------------|--------|-----|
| Cu-Be | Al-Bron | | | |
| 74240 | - | 160 | 130 | 230 |
| 74241 | - | | 150 | 250 |

NEW

 BOMBA MANUAL DE ACEITE / PORTABLE OIL PUMP / BURETTE À HUILE / TRAGBARE ÖLPUMPE / POMPA DELL'OLIO MANULE
DRAAGBARE OLIEPOMP / BOMBA MANUAL PARA ÓLEO

| COD | | Ø (mm) | L (mm) | UF |
|-------|---------|--------|--------|------|
| Cu-Be | Al-Bron | | | |
| 74243 | - | 165 | 1100 | 2300 |

NEW

CAZO / DIPPER / LOUCHE / TRICHTER KANNE / RECIPIENTE / BEERTRECHTER / CONCHA

| COD | | Ø (mm) | L (mm) | UF |
|-------|---------|--------|--------|------|
| Cu-Be | Al-Bron | | | |
| 74245 | - | 85 | 350 | 2300 |

NEW

 PLOMADA / LINER / CORDEAU RECHARGEABLE / SCHLAGSCHNURROLLER / GESSO TRACCIATORE / SLAGLIJNMOLEN
LINHAS DE TRAÇAR

| COD | | Ø MAX (mm) | L (mm) | UF |
|-------|---------|------------|--------|-----|
| Cu-Be | Al-Bron | | | |
| 72454 | 72455 | 60 | 50 | 250 |



POLEA / CHAIN HOIST / PALAN / KETTENZUG / PARANCHI A MANO CON CATENA / KETTINGAKEL / DIFERENCIAL MANUAL

| COD | | Kg. | CAP | Kg. |
|-------|---------|------|-----|-----|
| Cu-Be | Al-Bron | | | |
| 71638 | 71642 | 500 | 3 m | 14 |
| 71639 | 71643 | 1000 | | 18 |
| 71640 | 71644 | 2000 | | 22 |
| 71641 | 71645 | 3000 | | 30 |
| 72141 | 72142 | 5000 | | |



GRILLETE / SHACKLE / MANILLE / SCHÄKEL / GRILLI / SCHAKEL / MANILHA

| COD | | max. | a | b | L | UF |
|-------|---------|---------|----|----|----|-----|
| Cu-Be | Al-Bron | | | | | |
| 73429 | 73424 | 1200 kg | 30 | 50 | 55 | 170 |



CEPILLOS / BRUSHES / BROSSES / STAHLBÜRSTEN / SPAZZOLE / STAALBORSTELS / ESCOVAS

| COD | L | g |
|-------|-------|-----|
| 70479 | 3X350 | 170 |
| 70480 | 4X350 | 200 |
| 70481 | 5X350 | 220 |

LATON / BRASS / LAITON

| COD | L | g |
|-------|-------|-----|
| 71632 | 5X180 | 200 |

LATON / BRASS / LAITON

| COD | L | g |
|-------|-------|-----|
| 72739 | 3x350 | 150 |

LATON / BRASS / LAITON

| COD | L | g |
|-------|-------|-----|
| 73419 | 5x180 | 60 |
| 72526 | 4x290 | 170 |

LATON / BRASS / LAITON

| COD | Nº Filas Rows | L | g |
|-------|---------------|-----|-----|
| 61581 | 4 | 240 | 150 |

LATON / BRASS / LAITON

| COD | L | g |
|-------|----------|------|
| 71634 | 22.2x150 | 700 |
| 73426 | 32x200 | 1000 |

LATON / BRASS / LAITON



NEW



NEW



PICOS / PICKS / DECINTROIRES / MAURER HAMMERS / PICCONI / PICADEIRA

| Cu-Be | Al-Bron | L | H | B | Kg |
|-------|---------|------|-----|----|-----|
| 72143 | 72147 | 1050 | 360 | 53 | 1,1 |
| 72144 | 72148 | | 385 | 55 | 1,7 |
| 72145 | 72149 | | 410 | 56 | 2 |
| 72146 | 72150 | | 470 | | 2,5 |



HACHA / AXE / HACHE / AXTE / ASCIA / BIJLE / MACHADO

| Cu-Be | Al-Bron | L | H | B | g |
|-------|---------|-----|-----|----|-----|
| 72153 | 72154 | 340 | 200 | 98 | 950 |



HACHA BOMBERO / FIREMAN TYPE AXE / HACHE POUR POMPIERS / FEUERWEHRAXT / ASCIA TIPO PER POMPIERI
BRANDWEER BIJL / MACHADO DE BOMBEIRO

| Cu-Be | Al-Bron | L | H | B | Kg |
|-------|---------|-----|-----|----|-----|
| 72151 | 72152 | 340 | 145 | 82 | 1,3 |



Cu-Be cobre berilio / beryllium copper / cuivre beryllium / Kupfer Beryllium / koper beryllium / rame-berillio

Al-Bron aluminio bronce / aluminium bronze / alliage aluminium-bronze / Aluminium Bronze / aluminium brons / aluminio bronzo

MARTILLOS / HAMMERS / MARTEAUX / HÄMMER / MARTELLI / HAMERS / MARTELOS

 MARTILLO DE BOLA / BALL PEIN HAMMER / MARTEAU A BOULE / SCHLOSSER HAMMER / MARTELLO A PALLA
 ENGELSE HAMER / MARTELO DE BOLA

| COD | | L mm | gf |
|-------|---------|---------|-----|
| Cu-Be | Al-Bron | | |
| 70488 | 71743 | 280 | 200 |
| 70489 | 71744 | 310 | 500 |
| 70490 | 71745 | 340 | 700 |
| 70491 | 71746 | 350 | 900 |

 MARTILLO MECANICO DE PEÑA / ENGINEER'S CROSS PEIN HAMMER / MARTEAU A GARNIR / MECCANICO CON PENNA /
 SCHLOSSER HAMMER / MECÁNICO DE PENA

| COD | | L mm | gf |
|-------|---------|---------|-----|
| Cu-Be | Al-Bron | | |
| 70492 | 71747 | 310 | 500 |
| 70493 | 71748 | 350 | 900 |

 MARTILLO ALEMÁN / GERMAN TYPE MACHINIST'S HAMMER / MARTEAU DE MECANICIEN / SCHLOSSER HAMMER
 MARTELLO TEDESCO / BANKHAMER / MARTELO TIPO ALEMÃO

| COD | | L mm | gf |
|-------|---------|---------|------|
| Cu-Be | Al-Bron | | |
| 70494 | 71749 | 300 | 100 |
| 70495 | 71750 | | 200 |
| 70496 | 71751 | | 300 |
| 70497 | 71752 | 310 | 500 |
| 70498 | 71753 | | 800 |
| 70499 | 71754 | 340 | 1000 |
| 70500 | 71755 | 400 | 1500 |
| 70501 | 71756 | 450 | 2000 |

 MACETA OCTOGONAL / SLEDGE HAMMER / MASSE OCTOGONALE / SCHLAGHAMMER / MAZZETTA OTTOGONALE / MOKER HAMER
 MARRETA OCTOGONAL



| COD | | L mm | Kg |
|-------|---------|---------|-----|
| Cu-Be | Al-Bron | | |
| 70502 | 71757 | 370 | 1 |
| 70503 | 71758 | | 1,5 |
| 70504 | 71759 | | 2 |
| 70505 | 71760 | | 2,5 |
| 70506 | 71761 | | 3 |
| 70507 | 71762 | | 4,5 |
| 70508 | 71763 | | 5 |
| 70509 | 71764 | | 6,8 |
| 70510 | 71765 | 8 | |
| 72213 | 72211 | 900 | 10 |
| 72975 | 72974 | | 12 |

 MACETA CUADRADA TIPO ALEMÁN / GERMAN TYPE STONING HAMMER / MASSETTE TYPE ALLEMAND / FÄUSTEL / MAZZETA
 MARRETA

| COD | | Kg | L mm |
|-------|---------|-----|---------|
| Cu-Be | Al-Bron | | |
| 70511 | 71766 | 400 | 1 |
| 70512 | 71767 | | 1,5 |
| 70513 | 71768 | | 2 |
| 70514 | 71769 | | 2,5 |
| 70515 | 71770 | | 3 |
| 72098 | 72099 | 860 | 3,5 |





MARTILLO DE CORTE / CUT-OFF HAMMER / MARTEAU DE COUPE / SCHNEIDHAMMER / MARTELLO DE TAGLIO / LASBIKHAMER
MARTELO DE CORTE

| COD | |  |  |
|-------|---------|---|---|
| Cu-Be | Al-Bron | | |
| 70516 | 71771 | 400 | 1,3 |
| 70517 | 71772 | | 2,1 |





PICO DE CALDERERO / CHIPPING HAMMER / PIC DE CHAUDRONNIER / KESSELSTEINHAMMER / PICCONE DA BATTIRAME
PADEIRA DE CALDEIREIRO

| COD | |  |  |
|-------|---------|---|---|
| Cu-Be | Al-Bron | | |
| 70518 | 71773 | 280 | 200 |
| 70519 | 71774 | 355 | 400 |
| 70520 | 71775 | 400 | 600 |
| 70521 | 71776 | 400 | 900 |





MARTILLO PARA PIEDRA / STONE WEDGE / MARTEAU DE TAILLEUR DE PIERRE / MAURERHAMMER / MARTELLO PACCAPIETRE
DE CANTEIRO

| COD | |  |  |
|-------|---------|---|---|
| Cu-Be | Al-Bron | | |
| 70522 | 71777 | 400 | 1 |





PALA MARTILLO / BRICKLAYER'S HAMMER / PELLE-MARTEAU / MAURERHAMMER / MARTELLO PICCONE / PA-MARTELO

| COD | |  |  |
|-------|---------|---|---|
| Cu-Be | Al-Bron | | |
| 70523 | 71778 | 340 | 600 |
| 70524 | 71779 | 340 | 800 |





MARTILLO DE UÑA / CLAW HAMMER / MARTEAU D'EMBALLER / KLAUEN HAMMER / MARTELLO CARPENTIERE
MARTELO DE UNHA

| COD | |  |  |
|-------|---------|---|---|
| Cu-Be | Al-Bron | | |
| 70525 | 71780 | 275 | 500 |
| 70526 | 71781 | 338 | 700 |



MARTILLO DE NYLON / NYLON HAMMER / MARTEAU NYLON / PLASTIK HAMMER / MARTELLO DI NYLON / MARTELO DE NYLON



| COD | |  |  |  |
|-------|---------|---|---|---|
| Cu-Be | Al-Bron | | | |
| 70527 | 71782 | 50 | 340 | 800 |
| 73473 | 73393 | 55 | 400 | 1000 |





Cu-Be cobre berilio / beryllium copper / cuivre beryllium / Kupfer Beryllium / koper beryllium / rame-berillio

Al-Bron aluminio bronce / aluminium bronze / alliage aluminium-bronze / Aluminium Bronze / aluminium brons / aluminio bronzo

MACETA OCTOGONAL / SLEDGE HAMMER / MASSE OCTOGONALE / SCHLAGHAMMER / MAZZETTA OTTOGONALE / MOKER HAMER / MARRETA OCTOGONAL



| COD | |  |  |
|-----------|-----|---|---|
| Lat/Brass | | | |
| 72740 | 280 | 300 | |
| 72741 | 310 | 500 | |
| 72742 | | 1000 | |
| 72743 | 400 | 1500 | |
| 72744 | | 2000 | |
| 72745 | | 3000 | |
| 72746 | | 4000 | |
| 72747 | 900 | 5000 | |
| 72748 | | 7000 | |
| 72749 | | 10000 | |



| COD | |  |  |
|-------|-----|---|---|
| Cu | | | |
| 72750 | 350 | 450 | |
| 72751 | 400 | 1000 | |
| 72752 | 800 | 2500 | |
| 72753 | | 3600 | |
| 72754 | | 4500 | |
| 72755 | 900 | 5400 | |
| 72756 | | 6400 | |
| 72757 | | 10000 | |





MAZA TIPO TAMBOR / DRUM TYPE STONNIG HAMMER / MASSETTE CONIQUE / LEICHMETALLHAMMER / MAZZA TIPO A TAMBURO
LICHTMETALEN HAMER / MAÇO DE COBRE COM CABO DE FIBRA DE VIDRO

| COD | |  |  |
|-------|-----|---|---|
| Cu | | | |
| 72758 | 280 | 300 | |
| 72759 | 310 | 570 | |
| 72760 | 340 | 810 | |
| 72761 | 350 | 1100 | |
| 72762 | 400 | 1600 | |
| 72763 | | 2300 | |



MAZA CUADRADA TIPO ALEMAN / GERMAN TYPE STONING HAMMER / MASE CARREE TYPE ALLEMAND / STEINSCHLAGHAMMER /
STEINSLEGGER / MAZZA MARRETA QUADRADA

| COD | |  |  |
|-----------|-------|---|---|
| Lat/Brass | Cu | | |
| 72764 | 72773 | 350 | 500 |
| 72765 | 72774 | | 1000 |
| 72766 | 72775 | 400 | 1500 |
| 72767 | 72776 | | 1800 |
| 72768 | 72777 | | 2000 |
| 72769 | 72778 | | 2700 |
| 72770 | 72779 | 900 | 3600 |
| 72771 | 72780 | | 4000 |
| 72772 | 72781 | | 5000 |



24 ANTICHISPA / NON-SPARKING / ANTI-DEFLAGRANT / FUNKENFREI ANTISCINTILLA / VONKVRIJE / ANTI-DEFLAGRANTE



MARTILLO DE BOLA / BALL PEIN HAMMER / MARTEAU A BOULE / SCHLOSSERHAMMER / MARTELLO A PALLA / ENGELSE HAMMER
MARTELO DE BOLA

| COD | | L | W |
|-----------|-------|-----|------|
| Lat/Brass | Cu | | |
| 72782 | 72788 | 280 | 230 |
| 72783 | 72789 | | |
| 72784 | 72790 | 310 | 450 |
| 72785 | 72791 | 340 | 680 |
| 72786 | 72792 | 350 | 910 |
| 72787 | 72793 | 400 | 1130 |



MARTILLO DE PICAR / SCALING HAMMER / MASSETTE À PIQUER / SCHWEISSERHAMMER / LASHAMER
MARTELLO PER SCANALARE / PICADEIRA COM CABO DE FIBRA DE VIDRO

| COD | | L | W |
|-----------|----|-----|-----|
| Lat/Brass | Cu | | |
| 72794 | | 330 | 205 |
| 72795 | | 350 | 370 |



MACETA DE LATÓN / BRASS MALLET / MASSETTE LAITON / MESSINGHAMMER / MAZZETTA DI OTTONE / MESSINGHAMMER
MAÇO DE LATAO COM CABO DE FIBRA DE VIDRO

| COD | | L | W |
|-----------|----|-----|------|
| Lat/Brass | Cu | | |
| 72796 | | 900 | 4500 |
| 72797 | | | 5400 |
| 72798 | | | 7650 |



MACETA DE COBRE / COPPER MALLET / MASSETTE CUIVRE / KUPFERHAMMER / MAZZETTA DI RAME / KOPEREN HAMER
MARRETA DE COBRE COM CABO DE FIBRA DE VIDRO

| COD | | L | W |
|-------|----|-----|------|
| Cu | Cu | | |
| 72799 | | 350 | 1330 |



YUNQUE / ANVIL BLOCK / ENCCLUME / AMBOSSBLOCK / INCUDINE / AMBEELD / BIGORNA

| COD | | AxBxC (mm) | Kg |
|-------|---------|-------------|----|
| Cu-Be | Al-Bron | | |
| 73734 | 73735 | 92x92x63 | 3 |
| 73736 | 73737 | 111x111x75 | 5 |
| 73738 | 73739 | 160x160x114 | 16 |



Cu-Be cobre berilio / beryllium copper / cuivre beryllium / Kupfer Beryllium / koper beryllium / rame-berillio
Al-Bron aluminio bronce / aluminium bronze / alliage aluminium-bronze / Aluminium Bronze / aluminium brons / aluminio bronzo
Lat/Brass latón / brass / laiton / Messing / messing / ottone / latao
Cu cobre / copper / cuivre / Kupfer / koper / rame / cobre

ACETILEX: ALEACIÓN ACETILEX, TRABAJO SEGURO INCLUSO EN AMBIENTES DE ACETILENO
ACETILEX ALLOY, SAFE WORK EVEN IN ACETHYLENE ENVIRONMENTS
ALLIAGE ACETILEX, TRAVAIL SÛR MÊME EN PRÉSENCE D'ACÉTYLÈNE

LLAVES / WRENCHES / CLES / SCHLÜSSEL / CHIAVI / SLEUTELS / CHAVES

LLAVES COMBINADAS / COMBINATION WRENCHES / CLES MIXTES / RINGSCHLÜSSEL / CHIAVI COMBinate
RINGSTEEKSLEUTELS / CHAVES BOCA E LUNETE



mm

| COD |  |  |  |
|-------|---|---|---|
| 72867 | 6 | 115 | 36 |
| 72868 | 7 | 120 | 43 |
| 72869 | 8 | 125 | 50 |
| 72870 | 9 | 130 | 66 |
| 72871 | 10 | 135 | 72 |
| 72872 | 11 | 140 | 77 |
| 72873 | 12 | 145 | 94 |
| 72874 | 13 | 155 | 105 |
| 72875 | 14 | 165 | 110 |
| 72876 | 15 | 175 | 121 |
| 72877 | 16 | 185 | 165 |
| 72878 | 17 | 195 | 177 |
| 72879 | 18 | 205 | 208 |
| 72880 | 19 | 215 | 221 |
| 72881 | 20 | 225 | 250 |
| 72882 | 21 | 235 | 273 |
| 72883 | 22 | 245 | 294 |
| 72884 | 23 | 255 | 368 |
| 72885 | 24 | 265 | 399 |
| 72886 | 25 | 270 | 422 |
| 72887 | 26 | 275 | 441 |
| 72888 | 27 | 285 | 508 |
| 72889 | 28 | 293 | 552 |
| 72890 | 29 | 300 | 662 |
| 72891 | 30 | 310 | 689 |
| 72892 | 32 | 330 | 809 |



FIJA DE GOLPE / SLOGGING OPEN WRENCH / A FOURCHE A FRAPPER / SCHLAG MAULSCHLÜSSEL / FISSE AD IMPULSO
STEEKSLAGSLEUTEL / BOCA DE IMPACTO



mm

| COD |  |  |  |
|-------|---|---|---|
| 72901 | 30 | 185 | 457 |
| 72902 | 32 | 195 | 541 |
| 72903 | 36 | 210 | 761 |
| 72904 | 41 | 225 | 1003 |
| 72905 | 46 | 240 | 1286 |
| 72906 | 50 | 255 | 1407 |
| 72907 | 55 | 270 | 1748 |
| 72908 | 60 | 285 | 2003 |



ESTRELLA DE GOLPE / SLOGGING RING / POLYGONALE A FRAPPER / SCHLAG RINGSCHLÜSSEL / POLIGONALE AD IMPULSO
RINGSLAGSLEUTEL / LUNETE DE IMPACTO

mm

| COD |  |  |  |
|-------|---|---|---|
| 72893 | 30 | 163 | 420 |
| 72894 | 32 | 177 | 494 |
| 72895 | 36 | 208 | 609 |
| 72896 | 41 | 225 | 830 |
| 72897 | 46 | 243 | 1040 |
| 72898 | 50 | 254 | 1202 |
| 72899 | 55 | 264 | 1418 |
| 72900 | 60 | 275 | 1701 |







24 ANTICHISPA / NON-SPARKING / ANTI-DEFLAGRANT / FUNKENFREI ANTISCINTILLA / VONKVRIJE / ANTI-DEFLAGRANTE



ACETILEX: ALEACIÓN ACETILEX, TRABAJO SEGURO INCLUSO EN AMBIENTES DE ACETILENO
ACETILEX ALLOY, SAFE WORK EVEN IN ACETHYLENE ENVIRONMENTS
ALLIAGE ACETILEX, TRAVAIL SÛR MÊME EN PRÉSENCE D'ACÉTHYLÈNE

LLAVES HEXAGONALES / HEXAGONAL KEYS / CLES MALES / INBUSSCHLÜSSEL / CHIAVI ESAGONALI / INBUSSLEUTELS
CHAVES HEXAGONAIS

mm

| COD |  |  |  |  |
|-------|---|---|---|---|
| 72856 | 2 | 38 | 13 | 7 |
| 72857 | 3 | 59 | 25 | 9 |
| 72858 | 4 | 65 | 30 | 11 |
| 72859 | 5 | 79 | 32 | 18 |
| 72860 | 6 | 85 | 37 | 28 |
| 72861 | 7 | 88 | 43 | 37 |
| 72862 | 8 | 92 | 44 | 55 |
| 72863 | 9 | 97 | 44 | 67 |
| 72864 | 10 | 110 | 45 | 90 |
| 72865 | 11 | 119 | 48 | 125 |
| 72866 | 12 | 130 | 52 | 160 |







CUÑA / WEDGE / COIN / KEIL / WIG / CUNEO / CUNHA

| COD |  |  |  |
|-------|--|--|--|
| 72851 | 100x50 | 10-0 | 211 |
| 72852 | 150x50 | 13-0 | 420 |
| 72853 | 180x50 | 19-0 | 735 |
| 72854 | 200x50 | 12-0 | 525 |
| 72855 | 230x40 | 20-0 | 789 |







DESTORNILLADORES / SREWDRIVERS / TOURNEVIS / SCHRAUBENDREHER / CACCIAVITI
SCHROEVENDRAAIER / CHAVES DE VENDA

ELECTRICISTA / ELECTRICIEN / ELEKTRIKER / PER ELETTRICISTI / SCHROEVENDRAAIER VOOR SLEUFSCHROEVEN
MODEL ELEKTRICIEN / ELECTRECISTA

| COD |  |  |  |  |
|-------|---|---|---|---|
| 72825 | 50 | 3 | 83 | 41 |
| 72826 | | 4 | | 52 |
| 72827 | 100 | 5 | 103 | 105 |
| 72828 | | 6 | | 116 |
| 72829 | 150 | 8 | 112 | 160 |







PHILIPS

| COD |  |  |  |  |
|-------|---|---|---|---|
| 72830 | 60 | PH-0 | 83 | 44 |
| 72831 | 80 | PH-1 | | 77 |
| 72832 | 100 | PH-2 | 103 | 83 |
| 72833 | 150 | PH-3 | 112 | 182 |



POZIDRIV



| COD |  |  |  |  |
|-------|---|---|---|---|
| 72834 | 50 | PZ-0 | 83 | 39 |
| 72835 | 75 | PZ-1 | | 50 |
| 72836 | 100 | PZ-2 | 103 | 94 |
| 72837 | 150 | PZ-3 | 112 | 160 |



ACETILEX: ALEACIÓN ACETILEX, TRABAJO SEGURO INCLUSO EN AMBIENTES DE ACETILENO
ACETILEX ALLOY, SAFE WORK EVEN IN ACETHYLENE ENVIRONMENTS
ALLIAGE ACETILEX, TRAVAIL SÛR MÊME EN PRÉSENCE D'ACÉTHYLÈNE



MARTILLOS / HAMMERS / MARTEAUX / HÄMMER / MARTELLI / HAMERS / MARTELOS

MARTILLO DE BOLA / BALL PEIN HAMMER / MARTEAU A BOULE / SCHLOSSER HAMMER / MARTELLO A PALLA
ENGELSE HAMER / MARTELO DE BOLA

| COD |  |  |
|-------|---|---|
| 72838 | 310 | 500 |
| 72839 | 340 | 680 |
| 72840 | 350 | 910 |





MARTILLO ALEMAN / GERMAN TYPE MACHINIST'S HAMMER / MARTEAU DE MECANICIEN / SCHLOSSER HAMMER
MARTELLO TEDESCO / BANKHAMER / MARTELO TIPO ALEMÃO

| COD |  |  |
|-------|--|--|
| 72841 | 310 | 500 |
| 72842 | | 800 |
| 72843 | 340 | 1000 |



MACETA OCTOGONAL / SLEDGE HAMMER / MASSE OCTOGONALE / SCHLAGHAMMER / MAZZETTA OTTOGONALE
MOKER HAMER / MARRETA OCTOGONAL

| COD |  |  |
|-------|---|---|
| 72844 | | 1000 |
| 72845 | 400 | 1500 |
| 72846 | | 2000 |
| 72847 | | 3000 |
| 72848 | 900 | 4000 |
| 72849 | | 5000 |



PICO DE CALDERERO / CHIPPING HAMMER / PIC DE CHAUDRONNIER / KESSELSTEINHAMMER / PICCONE DA BATTIRAME
PICADEIRA DE CALDEIREIRO

| COD |  |  |
|-------|---|---|
| 72850 | 280 | 400 |



TITANIO
TITANIUM
TITANE



**ANTI-MAGNETICA DE TITANIO / NON-MAGNETIC TITANIUM
AMAGNETIQUE EN TITANE**

Las herramientas de Titanio EGA Master han sido desarrolladas con la más alta tecnología, y fabricadas en aleación de Titanio 6Al-4V, para ser usadas en los más exigentes y avanzados campos tales como la aviación, equipos hospitalarios, aplicaciones aeroespaciales y militares. Estas propiedades hacen que esta aleación sea la mejor que actualmente existe para aplicaciones críticas y especiales que requieren una gran capacidad mecánica, combinada con características que otra aleación no puede conseguir, como la de ser no-magnética etc. Muchas aplicaciones requieren herramientas completamente no magnéticas para no causar ninguna alteración, por ejemplo dispositivos muy sensibles usados en laboratorios, hospitales, centros de transformación, estaciones de radar, antenas etc.

EGA Master Titanium Tools have been developed with the help of the most advanced technology. They are manufactured with Titanium alloy, 6Al-4V, which has been used in the most innovative and advanced fields, such as aviation, military and aerospace applications. Its properties make this alloy the best one among the current existing ones for special and critical applications that require high mechanical properties, combined together with features that no other steel alloy tool can reach, like Non-Magnetism. Many applications require the use of totally non-magnetic tools in order to avoid any magnetic disturbance, such as very sensitive electronic devices used in laboratories, hospitals, power plants, etc.

L'outillage en Titane d' EGA Master a été développé avec la plus haute technologie, alliage de Titane 6Al-4V, utilisé dans les domaines les plus avancés et les plus techniques comme l'aviation, l'industrie militaire et les applications aérospaciales. Les propriétés du Titane font de cet alliage, le meilleur pour des applications critiques et spéciales qui requièrent une grande résistance mécanique, combinée avec d'autres caractéristiques que d'autres alliages de fer n'ont pas, comme l'amagnétisme. Beaucoup d'applications nécessitent des caractéristiques totalement amagnétiques, pour ne pas causer d'altération magnétique, par exemple, avec des dispositifs très sensibles utilisés dans les laboratoires, les hôpitaux et les centres de transformation...

| PROPIEDADES PROPERTIES PROPRIETES | APLICACIÓN Y BENEFICIOS APPLICATION & BENEFITS APPLICATIONS |
|---|---|
| 100% seguridad de anti-magnetismo 100% non-magnetic safety 100% sécurité anti-magnétique | Esencial para equipos que requieren una completa seguridad no magnética Essential for equipments that require complete non-magnetic safety, avoiding magnetic disturbance Essentiel pour des équipements nécessitant de l'outillage amagnétique |
| Inoxidable (más que el acero inoxidable) Rustproof (more than stainless steel) Inoxidable (plus que l'inox) | Especialmente concebidos para aplicaciones en entornos corrosivos como pueden ser en trabajos en la marina o de aplicaciones de bomberos Specially well suited for applications in corrosive environments like the ones encountered in marine works or fire-fighting applications Spécialement conçu pour des lieux à fort taux de corrosion, comme des travaux marins ou des utilisations par des pompiers |
| Extremadamente resistente al ácido Extremely Acid Resistant Extremely Acid Resistant | Perfecto para la industria química, herramienta duradera Perfect for Chemical Industry, long lasting tools Parfait pour l'industrie chimique, outillage à longue durabilité |
| Hipoalergénico Hypoallergenic Hipoalergénique | También apropiado por el incremento diario de alergias hacia materiales como el Ni, la alergia más frecuente, presente en la mayoría de las aleaciones de acero Also appropriate for the daily increasing allergies to materials such as Ni, the most frequent allergy, present on most of the steel alloys Aussi approprié pour éviter les allergies, tous les jours croissants, au matériau tel que le Nickel (allergie la plus fréquente), présent dans les alliages d'acier |
| 45% más ligero que el acero 45% lighter than steel 45% plus léger que l'acier | Evita las modernas y frecuentes lesiones causadas por movimientos de carga, como pueden ser la tendinitis o bursitis Avoids modern and frequent injuries caused by repetitive load movements, such as tendinitis or bursitis Fait éviter les lésions fréquentes du monde moderne telles que les tendinites, dues à la manipulation de poids |

MAT.: Ti 6Al-4V

| | | |
|--|-------------------------|-----------|
| Composición Composition Composition | V | 3,5%-4,5% |
| | Al | 5,5%-6,8% |
| | Otros / Others / Autres | <1% |
| Dureza / Hardness / Dureté | 30-40HRC | |
| Temperatura de fusión / Melting Temperatura / Temperature de fusion | 1650°C | |
| Resistencia a la tracción / Tensile Strength / Resistance à la traction | 993N/mm2 | |

PRINCIPALES CAMPOS DE APLICACIÓN / MAIN APPLICATION FIELDS / PRINCIPAUX CHAMPS D'APPLICATION

| PROPIEDAD ANTIMAGNÉTICA NON-MAGNETIC PROPERTY PROPRIÉTÉ ANTIMAGNÉTIQUE | INOXIDABLE Y RESISTENTE AL ÁCIDO RUSTPROOF AND ACID RESISTANT PROPERTIES INOXIDABLE EL RÉSISTANT À L'ACIDE |
|--|--|
| Marina / Navy / Marine | Trabajos al exterior/ Outdoor works Travaux extérieurs |
| Servicios de reparación de Electrónica y dispositivos Eléctricos Electronic and Electric device repairing services Services de réparation Electronique et dispositifs électriques | Construcciones de Diques Dock constructions Construction de docks |
| Fabricantes de Electrónica y dispositivos Eléctricos Electronic and Electric device manufacturers Fabricants d'électronique et de dispositifs électriques | Aplicaciones sub-acuáticas Scuba Diving applications Applications Sous-marines |
| Estaciones de servicio y energía Power stations Stations-service et energie | Industria química Chemical Industry Industrie chimique |
| Defensa / Defence / Defense | Bomberos / Fire-fighters / Pompiers |
| Fuerzas aéreas / Air Forces / Forces aériennes | Instalaciones de desalinización de aguas Water De-salination Installations Usine de désalement d'eau |
| Fabricante de armas Weapon fabrication Fabricants d'armes | Defensa / Defence / Defense |
| Trabajos ferroviarios / Railway works Travaux ferrovières | Fuerzas aéreas / Air Force / Forces aériennes |
| Telecomunicaciones / Telecommunication Telecommunications | Marina / Navy / Marine |
| Aplicaciones aeroespaciales Aerospace applications / Applications aérospaceales | Industrias farmacéuticas / Pharmaceutical Industries / Industrie Pharmaceutique |
| Aviación / Aviation / Aviation | Construcción de barcos / Ship building Construccion navale |
| Laboratorios de alta tecnología / High Tech Laboratorios Laboratoires de haute technologie | Plataformas exteriores de Gas y petróleo Offshore oil and gas platforms Plateformes extérieures de gaz et de pétrole |
| Hospitales (escanners, rayos X, MRI, ECG, Dispositivos desfibriladores) Hospitals (scanners, X-ray, MRI, ECG, Defibrillation devices, CRT...) Hopitaux (scanners, rayons X, MRI, ECG, Dispositifs desfibrilateurs) | Fabricas de sal Salt Industry Usine de sel |
| Industrias farmacéuticas / Pharmaceutical Industries Industrie pharmaceutique | |
| Industrias nucleares / Nuclear Industries / Industries nucleaires | |
| NMR imanes, espectrómetros, grandes imanes Tesla NMR Magnets, Spectrometers, High Tesla Magnets NMR aimans, spectromètres, électronique à raisonnance magnétique | |

INSTRUCCIONES DE USO Y GARANTÍA / INSTRUCTIONS FOR USE & WARRANTY / INSTRUCTIONS DE GARANTIE ET D'UTILISATION

1 Las herramientas de Titanio no pueden alcanzar la dureza de las herramientas convencionales, esto es debido al hecho de que la composición del material hace que sea imposible que sea inducida su dureza. Por esta razón el uso de las herramientas de Titanio debe tener un especial cuidado, evitando sobreesfuerzos.

Titanium Tools cannot reach the hardness of conventional tools, due to the fact that the material composition makes it impossible to be induction hardened. For this reason the use of Titanium Tools has to be carried out with special care, avoiding overstraining, heating, etc.

L'outillage Titane ne peut pas avoir la même dureté que l'outillage traditionnel, car la composition du matériau empêche l'induction de la dureté. Pour cela, il requière une attention spéciale, en évitant la rupture, la chaleur...

2 El uso de herramientas de Titanio no debe ser la única medida preventiva en áreas en las que se ha diseñado para ello. Otros objetos, como ropa o material presencial deben ser también adecuados.

The use of Titanium Tools must not be the only preventive measure in areas which the items are designed for. Other items, clothes or present material must also be adequate.

L'utilisation d'outillage en Titane ne doit pas être le seul moyen de prévention dans les environnements pour lequel il est conçu. D'autres objets, comme les vêtements et matériaux présents doivent aussi être adaptés aux applications anti-déflagrantes.

3 Las herramientas de Titanio de EGA Master tienen una garantía de por vida. En el caso de defecto de fabricación, deberá serán reparadas o reemplazadas sin ningún coste. El uso indebido es considerado como una excepción de la garantía.

EGA Master Titanium Tools are provided with lifetime warranty. In case an EGA Master tool breaks or fails to perform under normal and correct use, it will be repaired or replaced free of cost. Any misuse, abuse or normal service wear is considered as an exception to the warranty.

L'outillage en Titane d'EGA Master a une garantie à vie. Dans le cas d'une rupture ou en présence de vices à la livraison, l'outillage devra être réparé ou remplacé sans aucun surcoût. Une utilisation non conforme exclut la garantie.

25 ANTI-MAGNETICA DE TITANIO / NON-MAGNETIC TITANIUM AMAGNETIQUE EN TITANE



ALICATES / PLIERS / PINCES / ZANGEN / PINZE / UITVOERING / ALICATES

UNIVERSALES / COMBINATION / UNIVERSELLES / KOMBIZANGEN / UNIVERSALE / COMBINATIETANG / UNIVERSAIS

| COD |  |  |
|-------|---|---|
| 71646 | 160 | 150 |
| 71647 | 200 | 250 |



TELEFONISTA / LONG NOSE / TELEPHONE / TELEFONZANGEN / TELEFONISTI / TELEFOONTANG / TELEFONISTA

| COD |  |  |
|-------|---|---|
| 71648 | 180 | 100 |
| 71649 | 200 | 100 |



CORTE DIAGONAL / DIAGONAL CUTTING PLIERS / COUPANTES DIAGONALES / KRAFTSEITENSCHNEIDER / TAGLIO LATERALE
ZIKNIPTANG / CORTE DIAGONAL

| COD |  |  |
|-------|---|---|
| 71650 | 160 | 100 |
| 71651 | 200 | 100 |



ALICATE TIPO FORD / SLIP JOINT PLIER / PINCE BIPRISE / MECHANIKERZANGE / PINCE PER GASISTI
TANG DUBBELE INSTELLING / ALICATE MOTORISTA

| COD |  |  |
|-------|---|---|
| 71731 | 200 | 250 |



ALICATES CIRCLIPS / CIRCLIPS PLIERS / PINCES POUR CIRCLIPS / ZANGEN FÜR SICHERUNGSRINGE / PINZE PER ANELLI
BORGVEERTANGEN / ALICATES FREIOS

| COD |  |  |  |
|-------|---|---|---|
| 72082 | 180mm | 19-60 | 100 |



ALICATES PARA TERMINALES / CRIMPING PLIERS / PINCES A SERTIR LES COSSES / KABELKLEMMZANGE
KABELSCHDENTANG / PINZA PER CAPICORDA / ALICATE PARA CRAVAR TERMINAIS

| COD |  |  |
|-------|---|---|
| 71652 | 200 | 120 |



TENAZAS / PINCERS / ZANGE / TENAILLES / TENAGLIE / NIPTANG / ALICATES

PICO DE LORO / GROOVE JOINT / MULTIPRISE A CREMAILLERE / WASSERPUMPENZANGE / PINZE REGOLABILI
WATERPOMPTANG MET RILLENVERSTELLING / BICO DE PAPAGAIO

| COD |  |  |
|-------|---|---|
| 72532 | 250 | 250 |
| 72533 | 370 | 570 |



**PINZAS / TWEEZERS / BRUCELLES / GREIFFPINZETTEN / PINZETTE DI PRECISIONES
PINCETTES / PINÇAS**

| COD | | |
|-------|-----|----|
| 71657 | 155 | 30 |
| 71658 | 155 | 30 |
| 71659 | 155 | 30 |

LLAVES / WRENCHES / CLES / SCHLÜSSEL / CHIAVI / SLEUTELS / CHAVES

LLAVE AJUSTABLE / ADJUSTABLE WRENCH / CLE A MOLETTE / ROLLGABELSCHÜSSEL / CHIAVE REGOLABILI A RULLINO / VERSTELBARE STEUTEL / CHAVE AJUSTAVEL

| COD | | CAP | |
|-------|-----|------|-----|
| 71655 | 8" | 25mm | 110 |
| 71656 | 10" | 30mm | 220 |



LLAVE DINAMOMETRICA / TORQUE WRENCH / CLE DYNAMOMETRIQUE / DREHMOMENTSCHLÜSSEL / CHIAVE DINAMOMETRICA / CHAVE DINAMOMETRICA

| COD | | Nm | | |
|-------|------|--------|-----|-----|
| 74295 | 3/8" | 30-160 | 410 | 500 |
| 74296 | 1/2" | | | |





| COD | | Nm | | |
|-------|------|-------|-----|-----|
| 72540 | 3/8" | 10-15 | 310 | 400 |

 LLAVES FIJAS / OPEN-END WRENCHES / CLES PLATES / GABELSCHLUSSEL / CHIAVI FISSE / STEKSLEUTELS
CHAVES DUAS BOCAS



| COD | | |
|-------|---------------|-----|
| 71967 | 5-5,5mm | 20 |
| 71660 | 6-7mm | 20 |
| 71968 | 8-9mm | 20 |
| 71661 | 8-10mm | 20 |
| 71825 | 10-11mm | 30 |
| 71662 | 10-12mm | 30 |
| 71824 | 12-13mm | 40 |
| 71663 | 12-14mm | 50 |
| 71890 | 14-15mm | 70 |
| 71664 | 14-17mm | 100 |
| 71826 | 16-17mm | 100 |
| 71665 | 17-19mm | 100 |
| 71827 | 18-19mm | 100 |
| 71666 | 19-22mm | 150 |
| 71973 | 20-22mm | 150 |
| 71974 | 21-23mm | 150 |
| 71667 | 22-24mm | 150 |
| 71975 | 24-27mm | 250 |
| 71976 | 25-28mm | 250 |
| 71977 | 30-32mm | 300 |
| 71891 | 1/4-5/16" | 20 |
| 71892 | 5/16-3/8" | 20 |
| 71893 | 3/8-7/16" | 30 |
| 71894 | 1/2-9/16" | 50 |
| 71895 | 9/16-5/8" | 50 |
| 71896 | 19/32-11/16" | 100 |
| 71897 | 5/8-11/16" | 100 |
| 71898 | 11/16-3/4" | 100 |
| 71899 | 3/4-25/32" | 100 |
| 71900 | 3/4-7/8" | 150 |
| 71901 | 13/16-7/8" | 150 |
| 71902 | 15/16-1" | 200 |
| 71903 | 1-1.1/8" | 250 |
| 71904 | 1.1/16-1.1/8" | 250 |
| 71905 | 1.1/16-1.1/4" | 300 |



LLAVES COMBINADAS / COMBINATION WRENCHES / CLES MIXTES / GABELSCHLUSSEL / CHIAVI FISSE / STEEKSLEUTELS /
CHAVES DUAS BOCAS





| COD |  |  |
|-------|---|---|
| 71978 | 6mm | 20 |
| 71668 | 7mm | 30 |
| 71669 | 8mm | 30 |
| 71670 | 9mm | 30 |
| 71671 | 10mm | 40 |
| 71672 | 11mm | 40 |
| 71673 | 12mm | 40 |
| 71674 | 13mm | 50 |
| 71675 | 14mm | 50 |
| 71676 | 15mm | 100 |
| 71677 | 17mm | 100 |
| 71979 | 18mm | 125 |
| 71678 | 19mm | 150 |
| 71679 | 22mm | 200 |
| 71680 | 24mm | 250 |
| 71980 | 25mm | 270 |
| 71981 | 26mm | 300 |
| 71982 | 27mm | 350 |
| 71983 | 28mm | 350 |
| 71984 | 29mm | 400 |
| 71681 | 30mm | 410 |
| 71985 | 32mm | 450 |
| 71986 | 36mm | 500 |
| 71987 | 41mm | 750 |
| 71988 | 46mm | 1050 |
| 71828 | 7/32" | |
| 71829 | 15/64" | 15 |
| 71832 | 1/4" | 20 |
| 71830 | 5/16" | 30 |
| 71831 | 7/16" | 40 |
| 71833 | 1/2" | 50 |

LLAVES ACODADAS / DOUBLE OFFSET RING WRENCHES / CLES POLYGONALES / RINGSCHLUSSEL / CHIAVI POLIGONALI /
RINGSLEUTELS / CHAVES LUNETA

| COD |  |  |
|-------|---|---|
| 71989 | 5-5,5mm | 20 |
| 71682 | 6-7mm | 30 |
| 71990 | 6-8mm | 30 |
| 71991 | 8-9mm | 30 |
| 71683 | 8-10mm | 30 |
| 71992 | 9-11mm | 30 |
| 71993 | 10-11mm | 30 |
| 71684 | 10-12mm | 30 |
| 71994 | 11-13mm | 40 |
| 71995 | 12-13mm | 45 |
| 71685 | 12-14mm | 50 |
| 71996 | 13-15mm | 70 |
| 71997 | 14-15mm | 80 |
| 71998 | 14-16mm | 90 |
| 71686 | 14-17mm | 100 |
| 71687 | 17-19mm | 100 |
| 71999 | 18-19mm | 100 |
| 72000 | 18-20mm | 125 |
| 71688 | 19-22mm | 150 |
| 72001 | 20-22mm | 150 |
| 72002 | 21-23mm | 200 |
| 71689 | 22-24mm | 250 |
| 72003 | 24-27mm | 300 |
| 72004 | 25-28mm | 350 |
| 72005 | 26-29mm | 370 |
| 72006 | 27-30mm | 400 |
| 72007 | 30-32mm | 450 |
| 72008 | 28-36mm | 470 |
| 72009 | 32-36mm | 500 |
| 72010 | 41-46mm | 600 |





LLAVE DE CARRACA REVERSIBLE / REVERSIBLE RATCHET HANDLE / CLE A REVERSIBLE / UMSCHALTKNARRE /
CHIAVE A CRICCO REVERSIBLE / RATEL MET OMKEERMECHANISME / ROQUETE REVERSIBLE

| COD |  |  |  |  |
|-------|---|---|---|---|
| 71783 | 1/4" | 150 | | 180 |
| 71784 | 3/8" | 180 | | 230 |
| 71785 | 1/2" | 220 | | 300 |







LLAVES HEXAGONALES / HEXAGONAL KEYS / CLES MALES / INBUSSCHLÜSSEL / CHIAVI ESAGONALI / INBUSSLEUTEL
CHAVES HEXAGONAIS
STANDARD

| COD |  |  |  |  |
|-------|---|---|---|---|
| 71963 | 1,5 | 45 | 14 | 5 |
| 71964 | 2 | 48 | 16 | 10 |
| 71965 | 2,5 | 55 | 18 | 10 |
| 71966 | 3 | 62 | 20 | 15 |
| 72043 | 3,5 | 63 | 23 | 15 |
| 71712 | 4 | 69 | 25 | 20 |
| 71713 | 5 | 79 | 28 | 20 |
| 71714 | 6 | 90 | 32 | 50 |
| 71972 | 7 | 93 | 34 | 70 |
| 71715 | 8 | 99 | 36 | 90 |
| 72044 | 9 | 105 | 38 | 110 |
| 71716 | 10 | 112 | 40 | 130 |
| 72045 | 11 | 119 | 42 | 150 |
| 72046 | 12 | 126 | 45 | 180 |
| 72047 | 14 | 142 | 56 | 210 |
| 72048 | 17 | 161 | 63 | 250 |







SERIE LARGA / LONG SERIE / LANGE FORM / SERIE LUNGA / LANGE SERIE / SERIE LONGA

| COD |  |  |  |  |
|-------|--|--|--|--|
| 72049 | 1,5 | 90 | 14 | 10 |
| 72050 | 2 | 98 | 16 | 10 |
| 72051 | 3 | 109 | 20 | 15 |
| 72052 | 3,5 | 114 | 23 | 25 |
| 72053 | 4 | 119 | 25 | 30 |
| 72054 | 5 | 129 | 28 | 30 |
| 72055 | 6 | 145 | 32 | 55 |
| 72056 | 7 | 153 | 34 | 90 |
| 72057 | 8 | 159 | 36 | 120 |
| 72058 | 9 | 174 | 38 | 130 |
| 72059 | 10 | 182 | 40 | 160 |





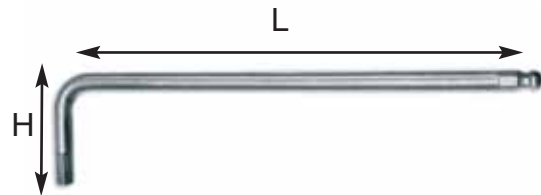

LLAVES HEXAGONALES DE BOLA / BALLPOINT HEXAGONAL KEYS / CLES MALES A TETE SPHERIQUE / KUGELKOPF
INBUSSCHLÜSSEL / CHIAVI ESAGONALI CON TESTA SFERICA / INBUSSLEUTEL MET BOLLE KOP / CHAVES HEXAGONAIS ESFE-
RICAS

| COD |  |  |  |  |
|-------|---|---|---|---|
| 72060 | 1,5mm | 88 | 14 | 5 |
| 72061 | 2mm | 99 | 16 | 10 |
| 72062 | 2,5mm | 109 | 18 | 10 |
| 72063 | 3mm | 125 | 20 | 15 |
| 71717 | 4mm | 139 | 25 | 20 |
| 71718 | 5mm | 155 | 28 | 20 |
| 72064 | 5,5mm | 155 | 28 | 30 |
| 71719 | 6mm | 176 | 32 | 50 |
| 72065 | 7mm | 188 | 34 | 70 |
| 71720 | 8mm | 201 | 36 | 90 |
| 72066 | 9mm | 215 | 38 | 110 |
| 71721 | 10mm | 228 | 40 | 130 |
| 72067 | 11mm | 244 | 42 | 150 |
| 72068 | 12mm | 258 | 45 | 180 |
| 72069 | 14mm | 276 | 56 | 210 |
| 72070 | 17mm | 299 | 63 | 250 |
| 71838 | 1/16" | 88 | 14 | 5 |
| 71839 | 5/64" | 99 | 16 | 10 |
| 71840 | 3/32" | 109 | 18 | 10 |
| 71841 | 1/8" | 125 | 20 | 15 |
| 71842 | 5/32" | 139 | 25 | 20 |
| 71843 | 3/16" | 155 | 28 | 20 |
| 71844 | 7/32" | 176 | 32 | 30 |
| 71845 | 1/4" | 188 | 34 | 60 |
| 71846 | 5/16" | 201 | 36 | 90 |
| 71847 | 3/8" | 215 | 38 | 120 |



25 ANTI-MAGNETICA DE TITANIO / NON-MAGNETIC TITANIUM AMAGNETIQUE EN TITANE

LLAVE ALLEN CON MANGO EN "T" / ALLEN KEY WITH "T" HANDLE / CLÉ HÉXAGONALE EMMANCHÉE EN T / INBUSSCHLÜSSEL MIT T-GRIFF / 6-KANT SLEUTEL MET T GREEP / CHIAVE A T ESAGONALE CON IMPUGNATURA IN PLASTICA / CHAVES MACHO SEXTAVADO COM CABO EM T



| COD |  |  |  |  |
|-------|---|---|---|---|
| 72503 | 3 | 43 | 155 | 65 |
| 72504 | 4 | | | |
| 72505 | 5 | | | |
| 72506 | 6 | 54 | 165 | 75 |
| 72507 | 8 | | | |
| 72508 | 10 | | | |



LLAVES DE VASO / SOCKET WRENCHES / DOUILLES / STECKSCHLUSSEL / BUSSOLE / DOPEN CHAVES DE CAIXA



1/4"

1/4" MM

| COD |  |  |
|-------|---|---|
| 71701 | 4 | 5 |
| 71702 | 5 | 5 |
| 71703 | 6 | 5 |
| 71704 | 7 | 5 |
| 71705 | 8 | 5 |
| 71706 | 9 | 10 |
| 71707 | 10 | 10 |
| 71708 | 11 | 15 |
| 71709 | 12 | 15 |
| 71710 | 13 | 20 |
| 71711 | 14 | 20 |



1/4" INCHES



| COD |  |  |
|-------|---|--|
| 72039 | 1/8" | 5 |
| 72040 | 3/16" | 5 |
| 72041 | 1/4" | 5 |
| 72042 | 3/8" | 10 |

MANGO CORREDIZO EN "T" / SLIDING "T" HANDLE / POIGNEE COULISSANTE / T-GLEITGRIFF / ASTA CON QUADRO ESCORREVOLO "T" WRINGSTAAF / CABO "T" CORREDIÇO

| COD |  |  |  |
|-------|---|---|---|
| 72497 | 1/4" | 150 | 150 |



ALARGADERA / EXTENSION / RALLONGE / VERLÄNGERUNG / PROLUNGA / VERLENGSTUK / EXTENÇÃO

| COD |  |  |  |
|-------|---|---|---|
| 72494 | 1/4" | 100 | 150 |
| 72495 | 1/4" | 150 | 200 |



3/8"

3/8" MM

| COD |  |  |
|-------|---|---|
| 72011 | 4 | 15 |
| 72012 | 5 | 15 |
| 72013 | 6 | 20 |
| 72014 | 7 | 20 |
| 72015 | 8 | 25 |
| 72016 | 9 | 25 |
| 71691 | 10 | 25 |
| 71692 | 11 | 25 |
| 71693 | 12 | 25 |
| 71694 | 13 | 25 |
| 71695 | 14 | 35 |
| 71696 | 15 | 45 |
| 71697 | 16 | 45 |
| 71698 | 17 | 60 |
| 71699 | 18 | 60 |
| 71700 | 19 | 60 |



3/8" INCHES

| COD | C |  |
|-------|---------|---|
| 72017 | 5/16" | 25 |
| 72018 | 3/8" | 25 |
| 72019 | 7/16" | 25 |
| 72020 | 1/2" | 25 |
| 72021 | 9/16" | 40 |
| 72022 | 5/8" | 45 |
| 72023 | 11/16" | 60 |
| 72024 | 1.1/16" | 80 |
| 72025 | 1.1/4" | 90 |



3/8" MM SERIE LARGA / LONG SERIE / LANGE FORM / SERIE LUNGA / LANGE SERIE / SERIE LONGA



| COD | C |  |
|-------|----|---|
| 72026 | 6 | 30 |
| 72027 | 7 | 30 |
| 72028 | 8 | 30 |
| 72029 | 9 | 30 |
| 72030 | 10 | 35 |
| 72031 | 11 | 35 |
| 72032 | 12 | 35 |
| 72033 | 13 | 35 |
| 72034 | 14 | 60 |
| 72035 | 15 | 70 |
| 72036 | 16 | 75 |
| 72037 | 17 | 90 |
| 72038 | 18 | 90 |

MANGO CORREDIZO EN "T" / SLIDING "T" HANDLE / POIGNEE COULISSANTE / T-GLEITGRIFF
ASTA CON QUADRO ESCORREVOLO / "T" WRINGSTAAF / CABO "T" CORREDIÇO



| COD |  |  |  |
|-------|---|---|---|
| 72498 | 3/8" | 250 | 250 |



ALARGADERA / EXTENSION / RALLONGE / VERLÄNGERUNG / PROLUNGA / VERLENGSTUK / EXTENÇÃO

| COD |  |  |  |
|-------|---|---|---|
| 72491 | 3/8" | 100 | 150 |
| 72492 | 3/8" | 200 | 250 |

ARTICULACIÓN UNIVERSAL / UNIVERSAL JOINT / CARDAN UNIVERSEL / KARDANGELLENK / SNODO CARDANICO
DOP MET CARDANGEWRIJCH / CARDAN UNIVERSAL

| COD |  |  |
|-------|---|---|
| 72500 | 3/8" | 100 |



BERBIQUÍ / SPEEDER HANDLE / VILLEBREQUIN / WINDE / LEVA GIROBECCHINO / OMSLAG / MANIVELA

| COD |  |  |  |
|-------|---|---|---|
| 72496 | 3/8" | 400 | 300 |

MANGO ACODADO / OFFSET HANDLE / MANCHE CONTRE COUDÉ / GEKRÖPFTE HANDGRIFF / DOPPIO MANICO /
GEBOGEN HANDVAT / CABO DESALINHADO

| COD |  |  |
|-------|---|---|
| 72502 | 3/8" | 300 |



25 ANTI-MAGNETICA DE TITANIO / NON-MAGNETIC TITANIUM AMAGNETIQUE EN TITANE

1/2"

1/2" MM

| COD | C |  |
|-------|----|---|
| 71850 | 7 | 25 |
| 71851 | 8 | 25 |
| 71852 | 9 | 25 |
| 71853 | 10 | 30 |
| 71854 | 11 | 30 |
| 71855 | 12 | 30 |
| 71856 | 13 | 30 |
| 71857 | 14 | 30 |
| 71858 | 15 | 35 |
| 71859 | 16 | 35 |
| 71860 | 17 | 35 |
| 71861 | 18 | 40 |
| 71862 | 19 | 40 |
| 71863 | 20 | 40 |
| 71864 | 21 | 45 |
| 71865 | 22 | 50 |
| 71866 | 23 | 55 |
| 71867 | 24 | 55 |
| 71868 | 25 | 60 |
| 71869 | 26 | 60 |
| 71870 | 27 | 65 |
| 71871 | 28 | 80 |
| 71872 | 29 | 90 |
| 71873 | 30 | 100 |
| 71874 | 31 | 105 |
| 71875 | 32 | 120 |



1/2" INCHES

| COD | C |  |
|-------|---------|---|
| 71876 | 1/4" | 25 |
| 71877 | 7/16" | 25 |
| 71878 | 1/2" | 30 |
| 71879 | 9/16" | 35 |
| 71880 | 5/8" | 35 |
| 71881 | 11/16" | 35 |
| 71882 | 3/4" | 40 |
| 71883 | 13/16" | 40 |
| 71884 | 7/8" | 50 |
| 71885 | 15/16" | 55 |
| 71886 | 1" | 60 |
| 71887 | 1.1/16" | 70 |
| 71888 | 1.1/8" | 90 |

MANGO CORREDIZO EN "T" / SLIDING "T" HANDLE / POIGNEE COULISSANTE / T-GLEITGRIFF
ASTA CON QUADRO ESCORREVOLO / "T" WRINGSTAAF / CABO "T" CORREDIÇO

| COD |  |  |  |
|-------|---|---|---|
| 72499 | 1/2" | 250 | 250 |



ALARGADERA / EXTENSION / RALLONGE / VERLÄNGERUNG / PROLUNGA / VERLENGSTUK / EXTENÇÃO

| COD |  |  |  |
|-------|---|---|---|
| 72493 | 1/2" | 100 | 150 |



ARTICULACIÓN UNIVERSAL / UNIVERSAL JOINT / CARDAN UNIVERSEL / KARDANGELENK / SNODO CARDANICO
DOP MET CARDANGEWIRCH / CARDAN UNIVERSAL

| COD |  |  |
|-------|---|---|
| 72501 | 1/2" | 150 |



**DESTORNILLADORES / SCREWDRIVERS / TOURNEVIS / HANDSCHRAUBER / CACCIAVITI
SCHROEVENDRAAIER / CHAVES DE FENDA**

ELECTRICISTA / ELECTRICIAN / ELECTRICIEN / ELEKTRIKER / SCHROEVENDRAAIER VOOR SLEUFSCHROEVEN / PER ELETTRICISTI

| COD | | | | |
|-------|-----|----|-----|-----|
| 72071 | 50 | 3 | | 50 |
| 71971 | 100 | 3 | | 60 |
| 71969 | 150 | 3 | 75 | 65 |
| 71722 | 100 | 4 | | 70 |
| 72072 | 150 | 4 | | 70 |
| 72073 | 100 | 5 | | 75 |
| 71723 | 150 | 5 | 92 | 80 |
| 72074 | 100 | 6 | | 90 |
| 72075 | 125 | 6 | 102 | 100 |
| 71970 | 150 | 8 | | |
| 71724 | 200 | 10 | 116 | |
| 71725 | 300 | 10 | | |



| COD | | | | |
|-------|-----|----|--|----|
| 72193 | 50 | 3 | | 50 |
| 72194 | 100 | 3 | | 60 |
| 72195 | 150 | 3 | | 70 |
| 72196 | 100 | 4 | | |
| 72197 | 150 | 4 | | |
| 72198 | 100 | 5 | | |
| 72199 | 150 | 5 | | |
| 72200 | 100 | 6 | | |
| 72201 | 125 | 6 | | |
| 72202 | 150 | 8 | | |
| 72203 | 200 | 10 | | |
| 72204 | 300 | 10 | | |

PHILIPS

| COD | | | | |
|-------|-----|------|-----|-----|
| 71726 | 75 | PH-0 | 75 | 50 |
| 71727 | 100 | PH-1 | 92 | 55 |
| 71728 | 150 | PH-2 | 110 | 70 |
| 71729 | 200 | PH-3 | | 80 |
| 71730 | 250 | PH-4 | 116 | 100 |



| COD | | | | |
|-------|-----|------|--|-----|
| 72205 | 75 | PH-0 | | 40 |
| 72206 | 100 | PH-1 | | 50 |
| 72207 | 150 | PH-2 | | 70 |
| 72208 | 200 | PH-3 | | 80 |
| 72209 | 250 | PH-4 | | 100 |



**DESTORNILLADOR ACODADO / OFFSET SCREWDRIVER / TOURNEVIS CONTRE COUDÉ / GEKRÖPFTE SCHRAUBENDREHER /
CACCIAVITE DOPPIO / GEBOGEN SCHROEVENDRAAIER / CHAVE DE FENDAS EM ÂNGULO**

| COD | | | |
|-------|--------|-----|----|
| 72528 | 4x0,8 | 100 | 10 |
| 72529 | 6x1 | 150 | 25 |
| 72530 | 10x1,5 | 250 | 90 |



MISCELANEA / MISCELLANEOUS / MELANGEE / VERSCHIEDENE / MISCELLANEA / DIVERSE
MISTURA

BOTADOR / PIN PUNCH / CHASE-GOUPILLES / SPLINTREIBER / PUNTE / DOORSLAG / PUNÇÃO



| COD | mm |  |  |
|-------|-------|---|---|
| 72077 | 2,5mm | 110 | 25 |
| 72078 | 3mm | 110 | 35 |
| 72079 | 4mm | 120 | 35 |
| 72080 | 5mm | 120 | 45 |
| 72081 | 6mm | 130 | 55 |

MARTILLO DE BOLA / BALL PEIN HAMMER / MARTEAU A BOULE / SCHLOSSER HAMMER / MARTELLO A PALLA / ENGELSE
HAMER / MARTELO DE BOLA

| COD |  |
|-------|---|
| 72083 | 450 |





TIJERA / SCISSORS / CISEAUX / SCHEREN / FORBICI / SCHAREN / TESOURA



| COD |  |  |
|-------|---|---|
| 71889 | 225mm | 180 |



CUCHILLOS / KNIVES / COTEAUX / MESSER / COLTELLI / MESSER / FACAS

| COD |  |  |  |
|-------|---|---|---|
| 72509 | 225 | 100 | 75 |
| 72527 | 250 | 130 | 80 |

CINCEL / FLAT CHISEL / CISEAUX DE MAÇON / MAURERMEISSEL / SCALPELLI PER MURATORI / METSELAARSBEITEL
ESCOPRO

| COD |  mm |  mm |  |
|-------|--|--|---|
| 72534 | 16 | 165 | 130 |
| 72535 | 22 | 125 | |



ESPATULA / SCRAPER / SPATULE / SPACHTEL / SPATOLA / SCHILDERMES / ESPATULA

| COD |  mm |  mm |  |
|-------|--|--|---|
| 72536 | 90 | 40 | 35 |



RAYADOR / MARKING TOOL / TRACEUR / MARKIERWERKEUG / ATREZZO PER MARCARE / ARKEER GEREEDSCHAP / RISCADOR

| COD |  |  |
|-------|---|---|
| 72531 | 200 | 12 |

BARRA PATA DE GALLO / CROW BAR / PINCE A LEVIER / BRECHSTANGE / BARRA A ZAMPA DI GALLO / BREEKSTANG
PÉ DE CABRA

| COD |  |  |
|-------|---|---|
| 72537 | 18" | 370 |

BARRA DE DESENCOFRAR / WRECKING BAR / PINCE MONSEIGNEUR / BRECHEISEN / APRICASSE CON LEVA CHIODI
BREEKIJZER / PE DE CABRA

| COD |  |  |
|-------|---|---|
| 72538 | 18" | 750 |





ATEX (Atmósfera - Explosiva)
ATEX (Explosive - Atmosphere)
ATEX (Atmosphère - Explosive)

designación ex / ex designation / désignation ex

ATEX (Atmósfera - Explosiva) / ATEX (Explosive - Atmosphere) / ATEX (Atmosphère - Explosive)

Directiva 94/9/EC

Articula las disposiciones legales a tomar por los estados miembros para los aparatos y sistemas de protección diseñados para su uso en áreas potencialmente explosivas.
Nuevo: ATEX 95 (Antiguo: ATEX 100a)

94/9/EC Directive

Harmonises legal provisions of member states for devices and protection systems for designated use in potentially explosive areas.

New: ATEX 95 (Old: ATEX 100a)

Directive 94/9/EC

Coordonne les dispositions légales à prendre dans les états membres pour les appareils et les systèmes de protection dessinés pour une utilisation dans des aires potentiellement explosives.
Nouveau: ATEX 95 (Ancien: ATEX 100a)

Directiva 1999/92/CE

Requerimientos mínimos para la mejora de la salud y la seguridad del trabajador en peligro ante atmósferas explosivas.

Nuevo: ATEX 137 (Antiguo: ATEX 118a)

1999/92/CE Directive

Minimum requirements for improving the health and safety protection of the worker at risk from explosive atmospheres.

New: ATEX 137 (Old: ATEX 118a)

Directive 1999/92/CE

Exigences minimum pour l'amélioration de la santé et de la sécurité du travailleur en danger dans des atmosphères explosives
Nouveau: ATEX 137 (Ancien: ATEX 118a)

Ejemplos de denominación: / Designation examples: / Exemples de désignations:

Uso en atmósferas gaseosas / Use in gaseous atmospheres / Utilisation en atmosphères gazeuses: II 1 G EEx ia IIC T4

Uso en atmósferas de polvo / Use in dusty atmospheres / Utilisation en atmosphères poussiéreuses: II 2 D T90°C IP64

Uso para aplicaciones de minería / Use for mining applications / Application pour des utilisations: I M2 EEx ia I



II 1 GD EEx ia IIC T4 T90°C IP64

Grupo de aparatos / Device group / Groupe d'appareils

I = minería / mining / minière
II = todas las demás áreas explosivas / all other explosive areas
tout le reste des zones explosives

Categoría / Category / Catégorie

1 = Zonas 0/20
2 = Zonas 1/21
3 = Zonas 2/22
M1= Minería (En caso de grisú, es posible seguir trabajando)
Mining (In case of firedamp, continuation of operation is possible)
Minier (En cas de grisou, le travail peut continuer)
M2= Minería (En caso de grisú, debe apagarse)
Mining (Must be switched off in case of firedamp)
Minier (En cas de grisou, on doit l'éteindre)

Atmósfera

G= Gas / gas / gaz
D= Polvo / dust / poussière
(Mining - no details)

Tipos de protección frente a la ignición:

Types of ignition protection:
Types de protections face à l'ignition:

o = inmersión en aceite / oil immersion
immersion dans l'huile
p = presurización / pressurisation / préssurisation
q = relleno de polvo / powder filling
rempli de poussière
d = carcasa resistente a la presión
pressure-proof housing
carcasse résistante à la pression
e = aumento de seguridad / increased safety
augmentation de la sécurité
ia = seguridad intrínseca (requerida para la Zona 0*)
*depende de la categoría del aparato
intrinsic safety (required for Zone 0*)
*depends on device category
sécurité intrinsèque (recommandé pour la zone 0*)
*dépend de la catégorie d'appareil
ib = seguridad intrínseca (adecuada para la Zona 1 (+2))
intrinsic safety (adequate for Zone 1 (+2))
sécurité intrinsèque (adequat pour les zones 1 (+2))
m = encapsulado / encapsulation / capsulé
s = protección especial / special protection
protection spéciale
n = funcionamiento normal bajo condiciones normales (sólo para la Zona 2)
normal operation under normal conditions (for Zone 2 only)
fonctionnement normal en conditions normales (uniquement zone 2)
nA = antichispa / non-sparking / anti-déflagrant
nC= contactos protegidos / protected contacts
contacts protégés
nR = carcasa resistente al vapor / vapour-proof housing / carcasse résistante à la vapeur
nL = energía limitada / limited energy / énergie limitée
nP = simplificada / simplified / simplifiée

Clases de temperatura:

(Máxima temperatura de una superficie en la que el gas puede penetrar en el caso de fallo del aparato. No debería usarse en las zonas Ex de polvo.)

Temperature classes:
(Max. temperature of a surface that gas can penetrate in the event of device failure. Should not be used in dust-ex-markings.)

Classes de température:
(Température maximum d'une surface dans laquelle le gaz peut pénétrer lors d'une défaillance de l'appareil. Ne doivent pas être utilisés dans les zones Ex de poussière.)

T1=450°C
T2 =300°C
T3 =200°C
T4 =135°C
T5 =100°C
T6 = 85°C

Grupo de explosión

(Dato facilitado para los aparatos usados en las áreas definidas como potencialmente explosivas por gas)

Explosion group
(Data only for devices used in areas rendered potentially explosive by gas)

Groupe d'explosion
(Renseignement donné pour les appareils utilisés dans les aires définies comme potentiellement explosives au gaz)

I= Metano (minería) / Methane (mining)
Méthane (mines)

IIA = Propano / Propane / Propane

IIB = Etileno / Ethylene / Ethylène

IIC = grupo más peligroso (e.j. hidrógeno)
most dangerous group (e.g. hydrogen)
groupe plus dangereux (e.x. hydrogène)

designación ex / ex designation / désignation ex

T90°C

Máxima temperatura superficial / Max. surface temperature
Température maximum en surface

(Dato facilitado para los aparatos usados en las áreas definidas como potencialmente explosivas por polvo –raramente también utilizado en las gaseosas.)

(Data for devices used in areas rendered potentially explosive by dust - rarely also used in gas ex marking.)

(Renseignements donnés pour les appareils utilisés dans les aires définies comme potentiellement explosives par la poussière et rarement utilisés dans des aires gazeuses.)

Máxima temperatura de una superficie en caso de fallo del aparato (o durante su uso normal en los aparatos de categoría 3) que puede ser alcanzada en una atmósfera Ex.

Evaluación por el usuario:

a) Temperatura límite 1=2/3 de la temperatura mínima de ignición del polvo presente.

b) Temperatura límite 2=mínima temperatura de quemado del polvo presente menos 75K (grados kelvin) (se aplica para capas de polvo de espesores de hasta 5mm).

El valor más pequeño de los límites de temperatura debe estar por encima de la máxima temperatura superficial indicada para el aparato.

Maximum temperature of a surface during a machine error (normal operation in the case of category 3 devices) that can be reached by the ex atmosphere.

Evaluation by the user:

a) Limit temperature 1=2/3 of min. ignition temperature of dust present

b) Limit temperature 2=min. glow temperature of dust present minus 75k (applies for layer thicknesses of up to 5mm)

The smaller value for the limit temperature must be above the indicated max. surface temperature of the device.

Température maximale d'une surface qui peut être atteinte dans une atmosphère Ex. dans le cas d'une défaillance d'un appareil (ou durant son utilisation normale dans les machines de catégorie 3)

Evaluation par l'utilisateur:

a) Température limite 1=2/3 de la température minimum d'ignition de la poussière présente

b) Température limite 2=température minimum de brûlure de la poussière présente moins de 75k (degrés kelvin) (elle s'applique pour des couches de poussières jusqu'à 5mm)

La valeur la plus basse de température doit être au-dessus de la température maximale superficielle indiquée pour l'appareil.

IP64

Código IP / IP Code / Code IP

(Dato facilitado sólo para aparatos usados en las áreas definidas como potencialmente explosivas por polvo.)

Data only for devices used in areas rendered potentially explosive by dust. Renseignements donnés uniquement pour les appareils utilisés dans des aires définies comme potentiellement explosives par la poussière.

Figure 1 Protección contra el contacto y cuerpos extraños:

5=Protección contra depósitos de polvo

6=Protección contra penetración de polvo

Figure 2 Protección contra el agua

Protección contra:

0=(no protección)

1=goteo vertical de agua

2=goteo de agua sobre aparato en funcionamiento inclinado 15°

3=agua pulverizada

4=agua pulverizada

5=chorro de agua

6=fuerte chorro de agua

7=inmersión temporal

8=inmersión continua

Figure 1 Contact and foreign body protection:

5=Protection against dust deposits

6=Protection against dust penetration

Figure 2 Water protection

Protection against:

0=(no protection)

1=vertically falling drip water

2=drip water on operating device inclined to 15° 3=spray water

3=spray water

4=spray water

5=jet water

6=strong jet water

7=temporary immersion

8=continuous immersion

Figure 1 Protection contre le contact et les corps étrangers:

5=Protection contre les dépôts de poussière

6=Protection contre la pénétration de poussière

Figure 2 Protection contre l'eau

Protection contre:

0=(pas de protection)

1=goutte verticale

2=gouttes d'eau avec une inclinaison de 15° sur un appareil en fonctionnement

3=eau pulvérisée

4=eau pulvérisée

5=jet d'eau

6=jet d'eau puissant

7=immersion temporaire

8=immersion continue



designación ex / ex designation / désignation ex

Protección frente a la explosión

Los principales principios para una segura e íntegra protección frente a la explosión son los siguientes:

1. Tomar medidas para evitar las atmósferas Ex siempre que sea posible.
2. Tomar medidas que prevengan la ignición de atmósferas Ex.
3. Tomar medidas que limiten los efectos de la explosión hasta un grado seguro.

Esto se diferencia de:

Protección primaria frente a la explosión:

Tomar precauciones para prevenir o restringir la formación de atmósferas Ex explosivas.

Protección secundaria frente a la explosión:

Éste abarca el segundo grupo de medidas, las cuales tienen la intención de prevenir la ignición de una atmósfera capaz de explotar.

Explosion Protection

The important principles for integrated safety explosion protection are as follows:

1. Measures are taken to avoid hazardous atmospheres whenever possible.
2. Measures are taken which prevent the ignition of hazardous atmospheres.
3. Measures are taken which limit the explosive effect to a safe degree.

This differs from:

Primary explosive protection:

These are precautions taken to prevent or restrict the formation of hazardous explosive atmospheres.

Secondary explosive protection:

This covers the second group of measures, which are intended to prevent the ignition of an atmosphere that is capable of exploding.

Protection contre l'explosion

Los principios los más importantes para una protección sûre e entière contre l'explosion sont les suivants:

1. Adopter les mesures nécessaires pour éviter tant que possible la zone Ex
2. Prendre les mesures de prévention contre l'ignition en atmosphère Ex
3. Prendre les mesures qui limitent les effets de l'explosion à un niveau nul

Celá se différencie de:

La protection primaire contre l'explosion:

Prendre des précautions pour prévenir ou réduire la formation d'atmosphères Ex explosives

La protection secondaire contre l'explosion:

Celui-ci comprend le second groupe de moyens, ceux qui ont l'intention de prévenir l'ignition d'une atmosphère qui peut exploser.

| Definición de acuerdo con la Directiva 1999/92/EC (Atex 137) Definition in accordance with 1999/92/EC Directive (ATEX 137) Définition en accord à la Directive 1999/92/EC (Atex 137) | Valores de referencia (no estandarizados) Reference values (not standardised) Valeurs de référence (non standardisés) | Zona Zone Zone | Debe usarse un aparato de la siguiente categoría (ver la Directiva 1999/92/EC - ATEX 137) A device from the following device category must be used (see 1999/92/EC-ATEX 137 Directive) On doit utiliser un appareil de la catégorie suivante (Voir la Directive 1999/92/EC - ATEX 137) | e |
|---|--|----------------------|--|---|
| Área donde con frecuencia o bien durante un largo periodo de tiempo está presente una atmósfera potencialmente explosiva mezcla de aire y gases inflamables, vapores o niebla. / Area in which a potentially explosive atmosphere as a mixture of air and flammable gases, vapours or mists is present either frequently or over a prolonged period. / Aire où fréquemment ou durant une longue période, une atmosphère potentiellement explosive avec un mélange d'air et de gaz inflammable, de vapeurs ou de brouillard, est présente | P>1000 h/a | 0 | 1 | G |
| Área donde bajo un funcionamiento normal puede formarse ocasionalmente una atmósfera potencialmente explosiva mezcla de aire y gases inflamables, vapores o niebla. / Area in which under normal operation a potentially explosive atmosphere as a mixture of air and flammable gases, vapours or mists can occasionally form. / Aire dans laquelle en conditions normales, peut se former occasionnellement une atmosphère potentiellement explosive avec un mélange d'air et de gaz inflammable, de vapeurs ou de brouillard. | 10...1000 h/a | 1 | 2 (1G también posible also possible aussi possible) | G |
| Área donde bajo un funcionamiento normal no se presenta normalmente una atmósfera potencialmente explosiva aunque puede presentarse durante un breve periodo de tiempo. / Area in which under normal operation a potentially explosive atmosphere as a mixture of air and flammable gases, vapours or mists is not normally present but may occur for just a short period. / Aire dans laquelle en conditions normales, il n'y a pas d'atmosphère potentiellement explosive, malgré une possibilité d'apparition sur de courtes durées. | <10 h/a | 2 | 3 (1G, 2G también posible / also possible aussi possible) | G |
| Área donde está presente constantemente, durante periodos prolongados o bien con frecuencia, una atmósfera potencialmente explosiva en forma de nube de polvo inflamable. / Area in which a potentially explosive atmosphere in the form of a cloud of flammable air-borne dust is present either constantly, over prolonged periods or frequently. / Aire dans laquelle, une atmosphère potentiellement explosive en forme de nuage de poussière inflammable, est constante ou présente sur de longues durées. | >1000 h/a | 20 | 1 | D |
| Área donde bajo un funcionamiento normal puede formarse una atmósfera potencialmente explosiva en forma de nube de polvo inflamable. / Area in which under normal operation a potentially explosive atmosphere in the form of a cloud of flammable air-borne dust can occasionally form. / Aire dans laquelle, en conditions normales, une atmosphère potentiellement explosive sous forme de nuage de poussières inflammables, peut se former. | 10...1000 h/a | 21 | 2 (1D también posible also possible aussi possible) | D |
| Área donde bajo un funcionamiento normal no se presenta normalmente una atmósfera potencialmente explosiva en forma de nube de polvo inflamable aunque puede presentarse durante un breve periodo de tiempo. / Area in which under normal operation a potentially explosive atmosphere in the form of a cloud of flammable air-borne dust is not normally present although may occur for just a short period. / Aire dans laquelle en conditions normales, une atmosphère potentiellement explosive sous forme de nuage de poussières n'est pas présente, mais peut apparaître un bref instant. | <10 h/a | 22 | 3 (1D, 2D también posible / also possible aussi possible) | D |

designación ex / ex designation / désignation ex

División en Clases de Temperatura

La indicación de la clase de temperatura puede garantizarse sólo si se respeta la temperatura ambiente especificada para el aparato en uso (mirar datos técnicos o chapa de características). Su estricto cumplimiento es un requisito obligatorio. Una vez que la máxima temperatura superficial de cualquier aparato alcance la temperatura de ignición de la atmósfera Ex circundante, puede ocurrir una explosión.

Debido a esto, todo equipo-material clasificado dentro del Grupo II se divide en clases de temperatura. Para tener en cuenta la posibilidad de atmósferas Ex potenciales, la temperatura de ignición más baja debe ser mayor que la máxima temperatura superficial.

Division into Temperature Classes

The temperature class indication can be guaranteed only if the ambient temperature specified for the operating device is respected (see Technical Data or Rating Plate). Strict compliance is a mandatory requirement. Once the maximum surface temperature of any apparatus reaches the ignition temperature of the surrounding hazardous atmosphere an explosion can occur.

Because of this, all equipment classified to Group II is divided into temperature classes. To allow for the possibility of potential hazardous atmospheres, the lowest ignition temperature must always be higher than the maximum surface temperature.

Division en classes de températures

L'indication de la classe de température peut être garantie uniquement si nous respectons la température ambiante, spécifiée pour l'appareil en fonctionnement (voir les renseignements techniques ou la table de caractéristiques). Son application stricte est une obligation. Quand la température superficielle maximale de tout appareil atteint la température d'ignition de l'atmosphère Ex circulant, il peut se produire une explosion.

C'est pour cela, que tout équipement - matériel classifié dans le Groupe II, est divisé en classes de températures. Pour prendre en compte, la possibilité d'atmosphère Ex potentielle, la température d'ignition la plus basse doit être supérieure à la température maximale superficielle.

Clases de temperatura de gases inflamables y vapores y temperaturas superficiales permitidas del aparato en uso de acuerdo con la DIN EN 50014
Temperature classes of flammable gases and vapours and permitted surface temperatures of the operating device in accordance with DIN EN 50014
Classes de températures de gaz inflammables et de vapeurs et de températures superficielles autorisées pour l'appareil utilisé en accord avec la norme DIN EN 50014

| Clase de temperatura Temperature class Classe de température | T1 | T2 | T3 | T4 | T5 | T6 |
|--|--|---|--|---|------|---|
| Temperatura de ignición (°C) Ignition temperature in °C Température d'ignition (°C) | >450 | >300 | >200 | >135 | >100 | >85 |
| Máxima temperatura superficial (°C) Maximum temperature in °C Température maximum superficielle (°C) | 450 | 300 | 200 | 135 | 100 | 85 |
| Ejemplos: Examples: Exemples: | Propano / Propane Propane Metano / Methane Méthane Amoniaco / Ammoniac Ammoniac | Etileno / Ethylene Ethylène Alcoholes / Alcohols Alcools Acetileno / Acetylene Acétylène | Petróleo / Petrol Pétrole Disolventes Solvents Dissolvents | Etiléter / Ethylether Etiléter Acetaldehído Acetaldehyde Acetaldehyde | - | Disulfuro de carbono Carbon-disulphide Disulfure de carbone |

Por debajo del nivel de explosión
Below Explosive Level
Au dessous du niveau d'explosion

Area Ex / Explosive Area / Zone Ex

Por encima del nivel de explosión
Above Explosive Level
Au dessus du niveau d'explosion

Mezcla pobre / Mixture too thin / Mélange pauvre

No combustión / No combustion / Pas d'explosion

No explosión / No explosion / Pas d'explosion



Mezcla rica / Mixture too rich / Mélange riche

Combustión parcial / Partial combustion / Combustion partielle

No explosión / No explosion / Pas d'explosion

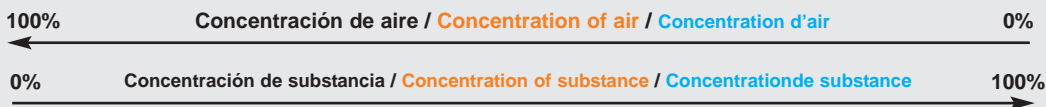

Las explosiones dependen de muchos parámetros. Sólo para condiciones atmosféricas y sustancias puras se muestran valores y datos suficientemente comparativos. Una explosión puede ocurrir solamente donde una sustancia inflamable en forma de gases, vapores, humos y polvo se encuentra con suficiente oxígeno para alimentar la combustión y allí es donde se localiza la fuente de ignición.

Ejemplo:
Hidrógeno: entre 4,0 y 77,0 % en aire
Propano: entre 1,7 y 10,6 % en aire
Amoniaco: entre 15,4 y 33,6 % en aire
Metano: entre 4,4 y 16,5 % en aire

Explosions are dependent on many parameters. Only for atmospheric conditions and pure substances sufficient comparative values and data are shown. An explosion can only occur where a flammable substance in the form of gases, vapours, smoke and dust exists along with sufficient oxygen to support combustion and there is a source of ignition.

E.g.:
Hydrogen: 4,0 to 77,0 % in air
Propane: 1,7 to 10,6 % in air
Ammonia: 15,4 to 33,6 % in air
Methane: 4,4 to 16,5 % in air

Les explosions dépendent de beaucoup de paramètres. Uniquement pour des conditions atmosphériques et des substances pures nous pouvons montrer des valeurs et des données suffisamment comparables. Une explosion peut se produire uniquement en présence de substances inflammables sous forme de gaz, de vapeurs, de fumées et de poussières, avec suffisamment d'oxygène pour alimenter la combustion, c'est, là que se trouve la source de l'ignition.

Exemple:
Hydrogène: entre 4,0 et 77,0 % dans l'air
Propane: entre 1,7 et 10,6 % dans l'air
Ammoniac: entre 15,4 et 33,6 % dans l'air
Méthane: entre 4,4 et 16,5 % dans l'air



Fundamentos de la protección frente a la explosión de polvo Fundamentals of dust explosion protection Bases de la protection contre l'explosion de poussières

Principios fundamentales:

El fabricante de aparatos en uso en áreas definidas como potencialmente explosivas por causas del polvo, debe indicar la máxima temperatura superficial de todos los aparatos en los que el polvo pueda penetrar (usualmente expresado en °C –la indicación de la clase de temperatura debería evitarse aquí). Esta temperatura es parte de la denominación Ex.

Ejemplos de denominación:

II 2 D T90°C IP64

(Si el tipo de protección frente a la ignición está basado en la carcasa, el ratio de protección de la carcasa debería también estar indicado por un código IP).

o II 2 D Ex iaD 21 T96°C

(Este aparato ya ha sido aprobado de acuerdo al nuevo estándar legal IEC "Seguridad Intrínseca del Polvo") –"iaD". Este estándar legal especifica que la denominación también contenga la zona correspondiente –en este caso 21).

Protección frente a la explosión de polvo – temperatura:

Los parámetros de combustión y explosión para el polvo dependen de su condición. Los parámetros que afectan al comportamiento de la combustión y la explosión incluyen el tamaño de las partículas, la forma de las partículas, el contenido de agua, la pureza y donde sea aplicable, el contenido de disolventes inflamables. La distribución del tamaño de las partículas y el valor medio (valor promedio de los tamaño de partícula) debería también ser conocido.

De acuerdo con la Directiva 1999/92/EG (ATEX 137, reemplazando a: ATEX 118a), el operario del sistema/empleador está obligado a hacer una evaluación sobre el peligro y debe por tanto saber la mínima temperatura de quemado del polvo.

Existen simples cálculos para determinar las dos "temperaturas" y son:

- Temperatura límite 1 = 2/3 de la temperatura mínima de ignición.
- Temperatura límite 2 = temperatura mínima de ignición* menos 75K.

Estas 2 temperaturas límite deben ser examinadas para confirmar cuál de ellas garantiza la mayor seguridad.

Ejemplo 1:

Temperatura mínima de ignición= +330°C,
Temperatura mínima de quemado= +300°C:

- Temperatura límite 1 = $2/3 \times +330^\circ\text{C} = +220^\circ\text{C}$
- Temperatura límite 2 = $+300^\circ\text{C} - 75\text{K} = +225^\circ\text{C}$

Mayor seguridad: Temperatura límite (1) = +220°C
Aquí debe usarse un aparato con una temperatura superficial máxima en caso de fallo $\leq +220^\circ\text{C}$. Según lo indicado, la denominación del aparato incluye el valor correspondiente.

Fundamental principles:

The manufacturer of operating devices for areas rendered potentially explosive through dust must indicate the maximum surface temperature of all devices that dust can penetrate (usually expressed in °C - indication of the temperature class should be avoided here). This temperature is part of the dust Ex-designation.

Designation examples:

II 2 D T90°C IP64

(If the ignition protection type is based on the housing, the housing protection rating should also be stated as an IP Code).

or II 2 D Ex iaD 21 T96°C

(This device has already been approved according to the new IEC de-jure standard "Intrinsic Dust Safety) - "iaD". This de jure standard specifies that the designation also contains the corresponding zone - in this case 21)

Dust explosion protection - temperature:

Combustion and explosion parameters for dusts depend on their condition. Parameters that affect combustion and explosion behaviour include particle size, particle shape, water content, purity and where applicable the content of the flammable solvents. The particle size distribution and the mean value (value for average particle size) should also be known.

In accordance with 1999/92/G Directive (ATEX 137, replacing: ATEX 118a), the system operator/employer is obliged to make a hazard assessment and must therefore be aware of the minimum glow temperature of the dust.

There are simple calculations to determine the two "temperatures" and they are carried out thus:

- Limit temperature 1 = 2/3 of minimum ignition temperature
- Limit temperature 2 = minimum ignition temperature* minus 75°K

These two limit temperatures must now be examined to confirm which guarantees the greater safety.

Example 1:

Minimum ignition temperature = +330°C,
minimum glow temperature = +300°C:

- Limit temperature 1 = $2/3 \times +330^\circ\text{C} = +220^\circ\text{C}$
- Limit temperature 2 = $+300^\circ\text{C} - 75^\circ\text{K} = +225^\circ\text{C}$

Greater safety: Limit temperature (1) = +220°C
Here a device with a max. surface temperature in the event of failure $\leq +220^\circ\text{C}$ must be used. As stated, the device designation includes a corresponding value.

Principes fondamentaux:

Le fabricant de matériel, destiné aux aires définies comme potentiellement explosives à cause de la poussière, doit indiquer la température maximum superficielle sur tous les appareils, à laquelle la poussière peut entrer (normalement exprimée en °C -l'indication de la classe de température devrait être évitée). Cette température fait partie de la désignation Ex.

Exemples de désignations:

II 2 D T90°C IP64

(Si le type de protection contre l'ignition est sur la carcasse, le ratio de protection de la carcasse devrait aussi être indiqué par un code IP).

ou II 2 D Ex iaD 21 T96°C

(Cet appareil a été déjà certifié suivant la nouvelle norme légale IEC "Sécurité intrinsèque de la poussière") -"iaD". Cette norme légale spécifie que la dénomination inclut aussi la zone correspondante, dans ce cas 21)

Protection contre l'explosion de poussière - température:

Les paramètres de combustion et d'explosion de la poussière dépendent de sa forme. Les paramètres qui conditionnent le comportement de la combustion et de l'explosion, incluent la taille, la forme des particules, le contenu de l'eau, la pureté et son lieu d'application, le contenu des dissolvants inflammables. La répartition de la dimension des particules et la valeur moyenne (valeur moyenne de la taille des particules) devrait être aussi connue.

En accord avec la directive 1999/92/EG (ATEX 137, remplaçant: ATEX 118a), l'opérateur du système/employé est obligé de faire une évaluation du risque et doit connaître au minimum la température minimale de combustion de la poussière.

Il existe de simples calculs pour déterminer les deux "températures" et ce sont:

- Température limite 1 = 2/3 de la température minimale d'ignition
- Température limite 2 = température minimale d'ignition* moins 75K

Ces deux températures minimales doivent être connues pour confirmer laquelle fournit la plus grande sécurité

Exemple 1:

Température minimum d'ignition= +330°C,
Température minimum de combustion= +300°C:
a) Température limite 1 = $2/3 \times +330^\circ\text{C} = +220^\circ\text{C}$
b) Température limite 2 = $+300^\circ\text{C} - 75\text{K} = +225^\circ\text{C}$

Plus grande sécurité: Température limite (1) = +220°C

Ici, nous devons utiliser un appareil d'une température maximale superficielle en cas de problème $\leq +220^\circ\text{C}$. Suivant l'indication, la dénomination de l'appareil inclut la valeur correspondante.

Fundamentos de la protección frente a la explosión de polvo Fundamentals of dust explosion protection Bases de la protection contre l'explosion de poussières

Ejemplo 2:

Temperatura mínima de ignición= +186°C,
Temperatura mínima de quemado= +180°C:
a) Temperatura límite 1 = $2/3 \times +186^\circ\text{C} = +124^\circ\text{C}$
b) Temperatura límite 2 = $+180^\circ\text{C} - 75\text{K} = +105^\circ\text{C}$

Mayor seguridad: Temperatura límite (2) = +105°C
Aquí debe usarse un aparato con una temperatura superficial máxima en caso de fallo $\leq +105^\circ\text{C}$.

*El valor para la temperatura de quemado se aplica con capas de polvo de espesores de 5mm. La temperatura de seguridad debe incrementarse para mayores espesores de capa.

Caso especial – Aparatos de Categoría 3

A diferencia de los aparatos de Categoría 1 y 2, para los aparatos de Categoría 3 (de uso solamente en las Zonas 2 y 22 respectivamente) no deben tenerse en cuenta los peligros potenciales en caso de fallo (cortocircuitos, conexiones rotas, etc.). El aparato se evalúa solamente respecto a los peligros durante un funcionamiento normal. Es relativamente poco probable que el aparato falle al mismo tiempo que se presenta una breve atmósfera explosiva. Por lo tanto no se requiere ningún Certificado de Test de Aprobación del Tipo EC para los aparatos de Categoría 3. El fabricante puede confirmar que el aparato en uso cumple con el pertinente estándar. Sin embargo, los aparatos EGA Master de Categoría 3 están todavía siendo probados por un centro de certificación y EGA Master está por ello concediendo declaraciones de conformidad. (Naturalmente, los aparatos de Categoría 2 también ofrecen una significativa seguridad en las Zonas 2 y 22 respectivamente).

Las explosiones por polvo - aunque su existencia sea de naturaleza menor - ocurren relativamente con mucha frecuencia.

Un folleto informativo de la Organización Gubernamental de la Salud de la República Federal de Alemania afirma:

"De acuerdo a la documentación publicada por las aseguradoras, se establece que ocurre por media una explosión por polvo al día en la República Federal de Alemania, de las cuales una cuarta parte es causada por polvos de alimentación."

Las explosiones por polvo son un problema global. En EEUU, entre 1980 y 1990, por ejemplo, se registraron alrededor de 200 explosiones por polvo serias con polvos de alimentación, siendo causa de 54 muertes, 256 heridos y un daños a la propiedad de más de 165 millones de dólares.

Example 2:

Minimum ignition temperature = +186°C,
minimum glow temperature = +180°C:
a) Limit temperature 1 = $2/3 \times +186^\circ\text{C} = +124^\circ\text{C}$
b) Limit temperature 2 = $+180^\circ\text{C} - 75^\circ\text{K} = +105^\circ\text{C}$

Greater safety: Limit temperature (2) = +105°C
Here a device with a max. surface temperature in the event of failure $\leq +105^\circ\text{C}$ must be used.

*The value for the glow temperature applies with a dust layer thickness of 5mm. The temperature safety distance must be increased for larger layer thicknesses.

Special case - Category 3 devices

In contrast to Category 1 and 2 devices, potential hazards in the event of failure (e.g. short circuiting, connection break etc.) do not have to be considered for Category 3 devices (for use only in Zones 2 respectively 22). The device is evaluated only in respect of hazards during normal operation, it is relatively unlikely that the device should fail at the same time as a short-term explosive atmosphere is present. No EC Type Approval Test Certificate is therefore required for Category 3 operating devices. The manufacturer may confirm that the operating device complies with the relevant standard. Nonetheless, EGA Master Category 3 devices are still tested by a certified centre and. EGA Master is then awarded a declaration of conformity. (- Of course, Category 2 operating devices also offer significantly greater safety in Zones 2 respectively 22.)

Dust explosions - albeit of a predominantly minor nature - occur relatively frequently.

A leaflet issued by the Government Safety Organisation of the Federal Republic of Germany states:

"According to documentation published by property insurers, it can be assumed that an average of one dust explosion per day occurs in the Federal Republic of Germany; around one in four of these explosions are caused by foodstuff or animal feed dusts."

Dust explosions are a world-wide problem. Between 1980 and 1990 in the USA, for example, some 200 serious foodstuff or animal feed related dust explosions were recorded, causing 54 deaths, 256 injuries and property damage amounting to 165 million US dollars.

Exemple 2:

Température minimale d'ignition= +186°C,
Température minimum de combustion= +180°C:
a) Température limite 1 = $2/3 \times +186^\circ\text{C} = +124^\circ\text{C}$
b) Température limite 2 = $+180^\circ\text{C} - 75\text{K} = +105^\circ\text{C}$

Plus grande sécurité: Température limite (2)= +105°C
Dans ce cas nous devons utiliser un appareil avec une température superficielle maximum en cas de problème de $\leq +105^\circ\text{C}$.

*La valeur pour la température de combustion s'applique sur les couches de poussière les plus épaisses de 5 mm. La température de sécurité doit être augmentée pour de plus grandes épaisseurs de couche.

Cas particulier - Appareils de Catégorie 3

A la différence des appareils de catégories 1 et 2, pour les appareils de catégorie 3 (d'utilisation uniquement en zones 2 et 22 respectivement) nous ne prenons pas en compte les dangers potentiels dus aux pannes (courcircuits, connexions défectueuses, etc.). L'appareil est uniquement évalué pour les dangers en fonctionnement normal. Il est relativement peu probable que l'appareil ait un problème en même temps que la présence d'une atmosphère explosive. Le Certificat de Test de contrôle du type EC n'est pas obligatoire pour les appareils de catégorie 3. Le fabricant peut confirmer que l'appareil utilisé remplit les conditions de la norme. Mais, les appareils EGA Master de Catégorie 3 sont testés par un centre de certification et c'est pour cela qu' EGA Master délivre une déclaration de conformité. (Naturellement, les appareils de catégorie 2 offrent aussi une sécurité significative dans les Zones 2 et 22 respectivement).

Les explosions par la poussière -malgré que leurs existences à l'état naturel ne sont pas fréquentes - elles se produisent relativement souvent.

Un dossier d'information de l'Organisation Gouvernementale de la Santé de la République fédérale allemande affirme que:

"Conformément à la documentation publiée par les compagnies d'Assurance, il est établi qu'il se produit chaque jour, en RFA, une explosion par la poussière, dont d'entre elles sont provoquées par des poussières alimentaires."

Les explosions par la poussière sont un problème global. En EEUU, entre 1980 et 1990, par exemple, furent dénombrées plus de 200 explosions sérieuses par la poussière alimentaire, provoquant 54 morts, 256 blessés et des destructions matérielles évaluées à 165 millions de dollars.

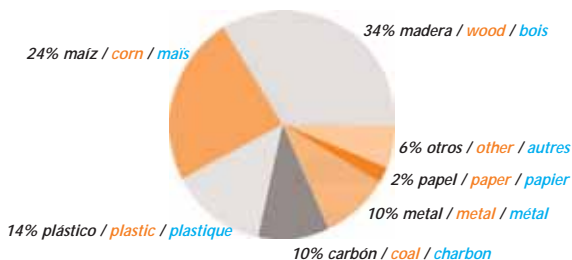

Explosiones de polvo por tipo de polvo
Dust explosions by dust type
Explosions de poudre par type de poudre

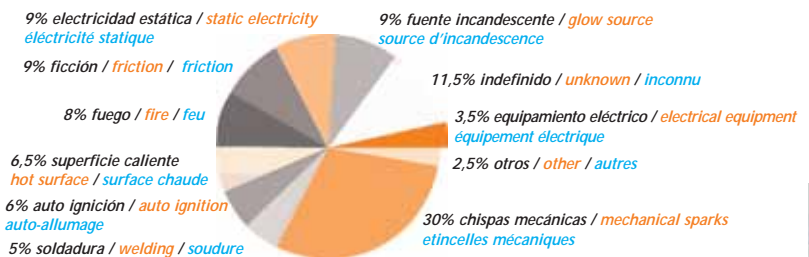

Fuentes de ignición de aparatos eléctricos
Ignition sources by electrical operating device type
Sources d'ignition d'appareils électriques



Fundamentos de la protección frente a la explosión de polvo Fundamentals of dust explosion protection Bases de la protection contre l'explosion de poussières

Las Fuentes de ignición de aparatos eléctricos representan solamente una pequeña proporción de las causas de ignición por polvo existentes -debido principalmente a las medidas de seguridad establecidas para la construcción de plantas eléctricas en zonas potencialmente explosivas.

La introducción de la regulación en plantas eléctricas en áreas potencialmente explosivas - ElexV" [1.4]- en 1980 especificó un tipo de certificado para los instrumentos eléctricos usados en la Zona 10 (desde 01.07.2003 en las Zonas 20 y 21).

Los instrumentos "protegidos contra explosiones por polvo", cuya temperatura superficial permanece por debajo del límite aceptable para una capa de polvo estandarizada de 5mm, pueden, aun cuando exista un certificado oficial, convertirse en fuente de peligro si, contrariamente a las condiciones, se cubren completamente por una capa espesa de polvo.

Electrical operating devices represent only a small proportion of the ignition sources found to cause dust explosions -not least due to the safety stipulations in the regulations for erecting electrical plants in potentially-explosive areas.

The introduction of the (Regulation on electrical plants in potentially-explosive areas) - ElexV" [1.4] in 1980 specified a type examination certificate for electrical operating devices used in Zone 10 (from 01.07.2003 in Zones 20 and 21).

"Dust explosion-protected" operating devices, the surface temperatures of which lies below the acceptable limit for standardised dust thickness of 5mm, can, despite the existence of an official test certificate, become a danger source if, contrary to the conditions, they become covered or completely encased with a thick layer of dust.

Les sources d'ignition d'appareils électriques représentent uniquement une petite proportion des causes d'ignition par les poussières existantes -Cela du principalement aux mesures de sécurité établies pour la construction d'usines électriques en zones potentiellement explosives.

L'introduction de la régulation dans les usines électriques dans des aires potentiellement explosives - ElexV" [1.4]- en 1980 précisa un type de certificat pour les appareils électriques utilisés en zone 10 (depuis 01.07.2003 dans les zones 20 et 21).

Les appareils "protégés contre les explosions par la poussière", dont la température superficielle reste au-dessous de la limite acceptable pour une couche de poussière d'une épaisseur standardisée de 5mm, peuvent, quand il existe un certificat officiel, devenir une source de danger si, contrairement aux conditions ils sont totalement couvert d'une épaisse couche de poussière.

Tipos de protección contra ignición Types of ignition protection Types de protections contre l'ignition

Tipo de ignición "n"

La protección contra ignición n se puede aplicar únicamente para aparatos de la categoría 3, empleados en áreas clasificadas como potencialmente explosivas por gases. Como aquí no se considera la operación normal y no se contemplan fallos de equipo, se dan pocas diferencias en la designación del tipo de protección contra ignición:

nA: equipo eléctrico antichispa (máquinas rotativas, fusibles, lámparas, indicadores y equipamiento de baja energía).

nC: equipos con generación de chispa o altas temperaturas superficiales en condiciones operativas.

nR: carcasa a prueba de vapores.

nL: equipamientos y circuitos de baja energía.

nP: carcasa contra sobrepresiones.

Ignition protection type "n"

Ignition protection type n is applicable only for Category 3 operating devices used in areas rendered potentially explosive by gases. Because only normal operation and no equipment failures are considered here, small differences occur in the designation for ignition protection type:

nA: non-sparking electrical equipment (revolving machines, fuses, lamps, gauges and equipment with low energy).

nC: Sparking equipment or equipment with hot surface under operating conditions (dosed indexing mechanism and non-ignitable components, air-tight equipment, leak-proof sealed equipment).

nR: vapour-proof casing.

nL: equipment and circuit with limited energy.

nP: simplified overpressure casing.

Type d'ignition "n"

La protección contra l'ignition ne peut être appliquée uniquement pour des appareils de catégorie 3, utilisés sur des aires classées comme potentiellement explosives par des gaz. Comme ici, l'opération n'est pas considérée normale, et nous ne tenons pas compte des pannes de l'équipement, il y a peu de différences dans la désignation du type de protection contre l'ignition:

nA: équipement électrique anti-déflagrant (machines rotatives, fusibles, lampes, indicateurs et équipement de basse tension)

nC: Equipements générateurs d'étincelles ou de hautes températures superficielles en conditions opérationnelles.

nR: carcasse à l'épreuve des vapeurs.

nL: équipements et circuits de basse tension.

nP: carcasse contre les surpressions.

Tipos de protección contra ignición Types of ignition protection Types de protections contre l'ignition

| Forma de la protección contra ignición Form of ignition protection Forme de la protection contre l'ignition | Descripción esquemática Schematic description Description schématique | Principio básico Basic principle Principe de base | standard |
|---|---|---|--|
| General | | Precauciones generales de diseño y comprobación del material eléctrico diseñado para zonas Ex. / General provisions for the design and testing of electrical equipment which is designed for the ex range. / Dispositions générales pour le dessin et le test électrique équipement désigné par le Zone ex. | EN 50014 |
| Seguridad incrementada Increased safety Sécurité augmentée | e | Sólo se aplica a equipos o componentes que normalmente no generan arcos o chispas, no consiguen altas temperaturas y los voltajes principales no superan 1kV. / Only applies to equipment or the components of which usually do not generate sparks or arcs, do not adopt dangerous temperatures and the mains voltage of which does not exceed 1 kV. / S'appliquent uniquement á des appareils ou des composants qui normalement ne génèrent pas d'arcs ni d'étincelles, n'arrivent pas á de hautes températures et á des voltage principaux inférieurs 1kV. | EN 50 019 IEC 60 079-7 FM 3600 UL 2279 |
| Carcasa a prueba de presión Pressure-proof casing Carcasse á l'épreuve de la pression | d | En caso de ignición dentro de la carcasa, la explosión es contenida en el interior. / In the case of an ignition inside the casing, the explosion is contained within the casing. / En cas d'ignition á l'intérieur de la carcasse, l'explosion est contenue. | EN 50 018 IEC 60 079-1 FM 3620 UL 2279 |
| Presurización Pressurisation Préssurisation | p | La fuente de ignición esta sellada por un gas protector de ignición bajo presión. La atmósfera medioambiental no puede introducirse en el gas protector de ignición. / Ignition source is sealed in by an ignition protection gas which a under overpressure (mind, 0.5 mbar) Ignition protection gas the environment atmosphere cannot enter. / La source d'ignition est isolée par un gaz protecteur sous pression. L'atmosphère du milieu-ambient ne peut entrer en contact avec le gaz protecteur. | EN 50016 IEC 60 079-2 FM 3620 NFPA 496 |
| Seguridad intrínseca Intrinsic safety Sécurité intrinsèque | i | Se evitan arcos, chispas y altas temperaturas a través de la restricción en la energía del circuito. / By restriction of the energy in the circuit the development of inadmissibly high temperatures, ignition sparks and arcs are avoided. / On évite les arcs, les étincelles et les hautes températures au travers de la restriction de l'énergie du circuit. | EN 50 020 IEC 60 079-11 FM 3610 UL 2279 |
| Inmersión en aceite Oil immersion Immersion dans l'huile | o | El equipo o parte de él es sumergido en aceite, el cual los separa del ambiente. / Equipment or parts of the equipment are put into an oil casing - by which they are separated from the ex atmosphere. / Tout ou partie de l'équipement est immergé dans de l'huile, ce qui l'isole de l'air ambient. | EN 50 015 IEC 60 079-6 FM 3600 UL 2279 |
| Relleno de polvo Powder filling Rempli de poussière | q | La fuente de ignición esta encapsulada en arena de grano fino, lo que evita que el ambiente EX no pueda ser prendido por un arco. / Ignition source encased by fine-grained sand -the environment ex atmosphere cannot be ignited by an arc. / La source d'ignition est capsulée dans du sable très fin, ce qui évite que l'air ambient EX ne puisse être atteint par un arc. | EN 50 017 IEC 60 079-18 FM 3600 |
| Encapsulación Encapsulation Capsulage | m | Encapsulando la fuente de ignición en un material lechoso, no puede prender la atmósfera Ex. / By encapsulating the ignition source into a grouting material, it cannot ignite an ex atmosphere. / La source d'ignition est capsulée dans un matériau laiteux, elle ne peut être atteinte par l'atmosphère Ex. | EN 50 028 IEC 60 079-18 FM 3600 UL 2279 |
| No incendiaria Non-incendive Pas d'allumage | n <p>Zona 2. En esta forma de protección contra la ignición se combinan varios métodos de protección contra la ignición. Zone 2. In this form of ignition protection multiple methods of ignition are combined. Zone 2. Dans cet etui de protection contre l'ignition multiples methods d'ignition protection est combinée.</p> | Aplicación ligeramente simplificada de otras formas de protección contra la ignición de la zona 2 - "n" simboliza "no incendiaria". Slightly simplified application of other zone-2 forms of ignition protection - "n" stands for "non-incendive". Application très simple de une autre zone-2 forme of ignition protection - "n" stands for "non-incendive". | EN 50 021 IEC 60 079-15 |



Grado de protección IP / IP degree protection / IP grade de protection

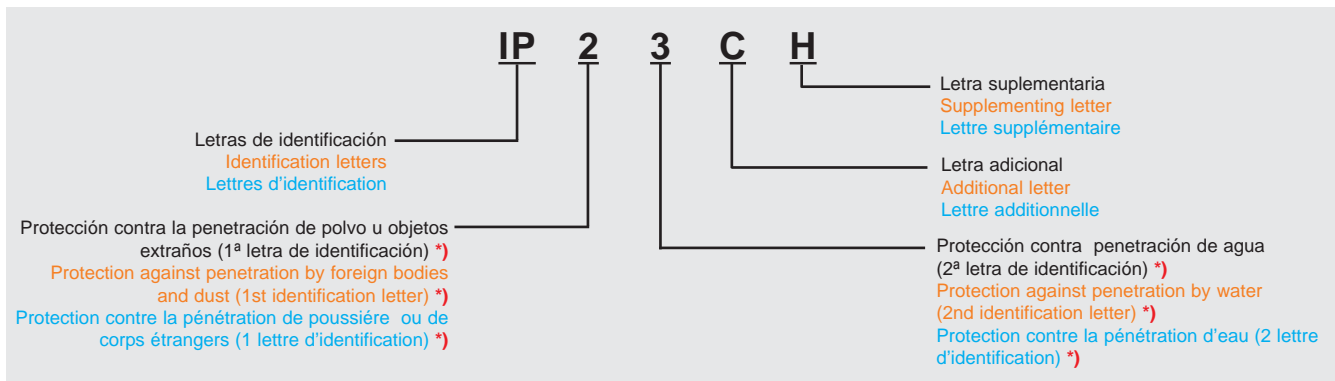

*) Si el grado de protección no debiera ser especificado, entonces los caracteres se reemplazan por una X ej. IP X4

*) Should no degree of protection be specified, then the characters are replaced with the letter X e.g. IP X4

*) Si le grade de protection ne devrait pas être spécifié, alors les caractères seraient remplacés par un X ex. IP X4

| 1ª letra ident 1st ident letter 1 lettre ident | Grado de protección Degree of protection Grade de protection | Símbolo Symbol Symbole |
|--|--|------------------------------|
| 0 | Sin protección / No protection / Sans protection | |
| 1 | Protección contra penetración de partículas extrañas de gran tamaño, 0>50 mm. Sin protección contra acceso intencionado. / Protection against penetration by large foreign bodies, 0>50 mm. No protection against intentional access / Protection de pénétration de particules étrangères de grande taille, 0>50 mm. Sans protection contre une entrée volontaire. | |
| 2 | Protección contra penetración de partículas extrañas de pequeño tamaño 0>12,5 mm, exclusión de dedos u objetos similares. / Protection against small foreign bodies, 0>12,5 mm, exclusion of fingers or similar objects. / Protection contre la pénétration de particules étrangères de petite taille, 0>12,5 mm, exclusion faite de doigts ou objets similaires. | |
| 3 | Protección contra penetración de partículas extrañas de pequeño tamaño, 0>2,5 mm, exclusión de herramientas, cables u objetos similares. / Protection against small foreign bodies, 0>2,5mm, exclusion of tools, wires or similar objects. / Protection contre la pénétration de particules étrangères de petite taille, 0>2,5 mm, hors outils, cables ou objets similaires. | |
| 4 | Protección contra partículas granulares, 0>1mm, exclusión de herramientas, cables u objetos similares. / Protection contre des particules granuleuses, 0>1mm, hors outils, cables ou objets similaires. / Protection contre des particules granuleuses, 0>1mm, hors outils, cables ou objets similaires. | |
| 5 | Protección contra deposiciones de polvo (protección contra polvo), exclusión completa de acceso. / Protection against dust deposits (dustprotected), complete exclusion of access. / Protection contre des dépôts de poussières (protection contre poussière), totalement hermétique. | |
| 6 | Protección total contra deposiciones de polvo (protección contra polvo), exclusión completa de acceso. / Totally protection against dust deposits (dust protected), complete exclusion of access. / Protection totale contre dépositions de poussière (protection contre poussière), complète exclusion d'accès. | |

| 1ª letra ident 1st ident letter 1 lettre ident | Grado de protección Degree of protection Grade de protection | Símbolo Symbol Symbole |
|--|--|------------------------------|
| 0 | Sin protección / No protection / Sans protection | |
| 1 | Protección contra caída de agua cayendo de forma vertical. / Protection against drops of water falling vertically (water drop) / Protection contre la tombée d'eau de forme verticale. | |
| 2 | Protección contra caída de agua en ángulo, inclinado a 15° de la posición normal de operación. / Protection against water falling at an angle (water drop), inclined at 15° to the normal operating position. / Protection contre des chutes d'eau, inclinées a 15° par rapport à la position normale. | |
| 3 | Protección contra spray de agua, hasta 60° de la vertical. / Protection against water spray, up to 60° from the vertical. / Protection contre des brumisations, jusqu'à 60° de la verticale. | |
| 4 | Protección contra salpicaduras de agua desde cualquier dirección. / Protection against water splashes from any direction. / Protection de projections d'eau de toutes directions. | |
| 5 | Protección contra chorro de agua desde cualquier dirección. / Protection against water jet from any direction. / Protection de jets d'eau provenant de toutes directions. | |
| 6 | Protección contra mar ajetreado o fuerte chorro de agua (Protección contra inundaciones). / Protection against heavy sea or strong water jet (Flooding protection). / Protection contre une tempête ou un fort jet d'eau (Protection contre les inondations) | |
| 7 | Protección contra inmersión en agua a cierta presión durante cierto tiempo. / Protection against submersion in water at a certain pressure and for a certain period. / Protection contre immersion en l'eau à certaine pression et pendant certain temps. | |
| 8 | Protección contra inmersión en agua continua. / Protection against continuous submersion in water. / Protection totale contre une immersion dans l'eau. | |

| Letra adicional Additional letter Lettre additionnelle | Significado (facultativo) Significante (facultative) Significatif (facultatatif) |
|--|--|
| A | Parte posterior de la mano / Back of the hand / Partie postérieure de la main |
| B | Dedo / Finger / Doigt |
| C | Herramientas / Tools / Outils |
| D | Cable / Wire / Cable |

| Letra suplementaria Supplementing letter Lettre supplémentaire | Significado (facultativo) Significante (facultative) Significatif (facultatatif) |
|--|--|
| H | Aparato de alto voltaje / High voltage apparatus / Appareil de haut voltage |
| M | Máquina en marcha / Machine running / Machine en marche |
| S | Máquina parada / Machine not running / Machine arrêtée |
| W | Condiciones meteorológicas / Weather conditions / Conditions météorologiques |

Division por zonas / Division into zones / Division par zones

La seguridad es nuestra primera prioridad

En todos los lugares donde se produzcan, procesen, transporten o almacenen sustancias inflamables, la seguridad es extremadamente importante- especialmente en las industrias químicas y petroquímicas, en la producción de petróleo y gas natural y en la minería.

Con el objetivo de proveer el mayor nivel de seguridad, la mayoría de las legislaciones estatales han desarrollado leyes y regulaciones al respecto. En un entorno cada vez más globalizado, se han dado pasos importantes en la estandarización y puesta en común de las guías a seguir en la protección contra explosiones. Es la Unión Europea la que abanderará este camino. La directiva 94/9/EG supuso el comienzo hacia la unificación. Desde el 1 de Julio de 2003 todos los aparatos deben estar aprobados según esta directiva.

Significado de la clasificación por zona:

Zona 0/20: Peligro presente en todo momento, por largos periodos de tiempo o frecuentemente.

Zona 1/21: Peligro presente ocasionalmente.

Zona 2/22: Peligro presente de forma poco frecuente o por corto espacio de tiempo.

Safety is our first st priority

At all places where inflammable substances are produced, processed, transported or stored, safety is extremely important - especially in the chemical and petrochemical industry, in oil and natural gas production and in mining.

In order to provide the highest level of safety possible, most state's legislations have developed corresponding conditions in the form of laws, regulations and standards. In the course of globalisation, enormous progress could be made in uniform guidelines for explosion protection. It is the European Union that is leading the way. The 94/9/EG guideline lays the foundation for a complete unification. As of 01 July 2003, all new devices must be approved in accordance with this guideline.

Meaning of the zone classification:

Zone 0/20: Danger is always present, for a long time or frequently

Zone 1/21: Danger is occasionally present

Zone 2/22: Danger is seldom present or present for a short time

La sécurité est notre première priorité

Dans tous les lieux où on produit, transforme, transporte ou emmagasine des substances inflammables, la sécurité est extrêmement importante- spécialement dans l'industrie chimique et pétrochimique, dans la production de pétrole et de gaz et dans les mines.

Ayant pour objectif d'atteindre le plus haut niveau de sécurité, la plus grande partie des législations étatiques, a développé des lois et des réglementations à ce sujet. Dans un environnement toujours plus globalisé, de grands pas ont été faits pour la normalisation et la mise en commun des chemins à suivre pour la protection contre les explosions. C'est l'Union Européenne qui a initié ce chemin. La directive 94/9/EG fut mise en oeuvre lors de l'unification. Depuis le 1^{er} juillet 2003 tous les appareils doivent être approuvés suivant cette directive .

Signification de la classification par zone:

Zone 0/20: Danger présent à tout moment, par longues ou fréquentes périodes .

Zone 1/21: Danger présent occasionnellement.

Zone 2/22: Danger présent peu fréquent ou sur de très courtes durées.

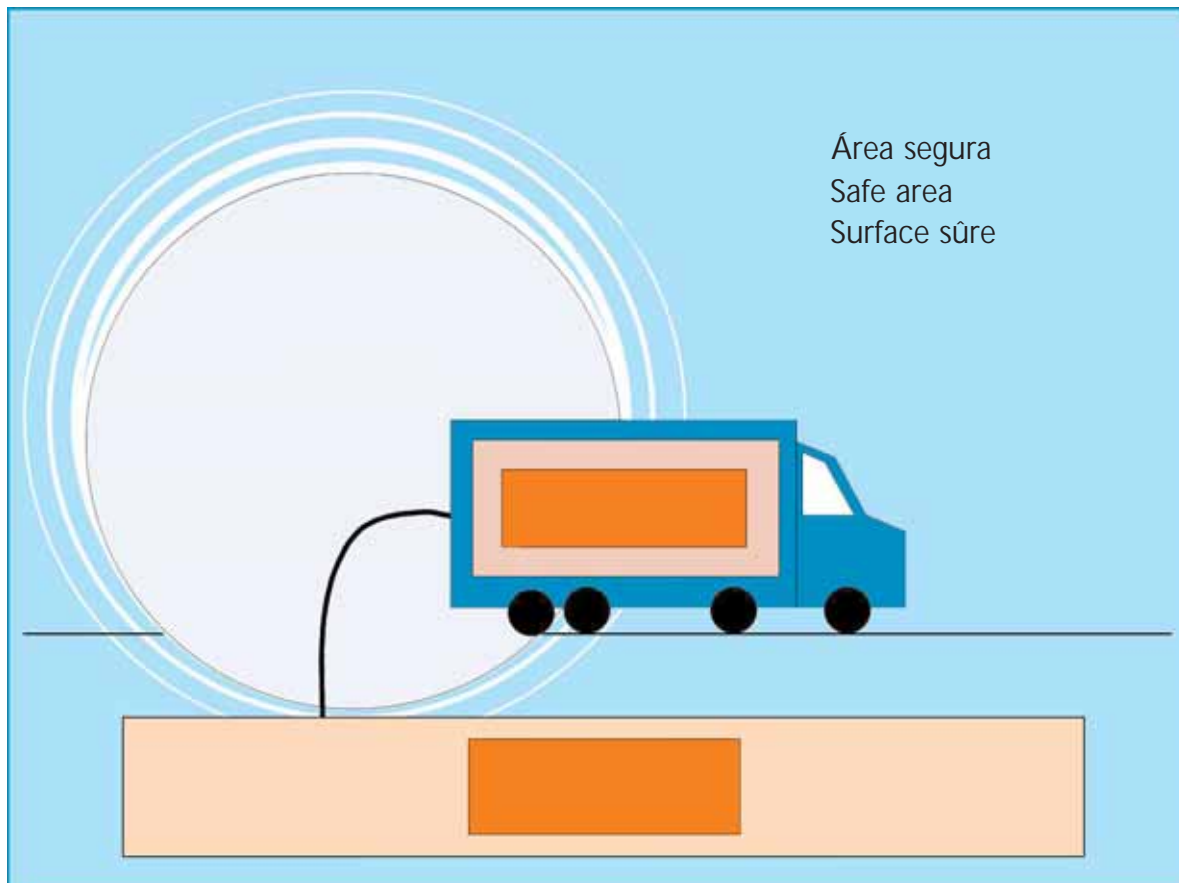

COMUNICACIÓN / COMMUNICATION / COMMUNICATION

TELÉFONO MÓVIL INTRÍNSECAMENTE SEGURO MASTEREX-HANDY 04
INTRINSICALLY-SAFE MOBILE PHONE MASTEREX-HANDY 04
TÉLÉPHONE PORTABLE INTRINSÈQUEMENT SÛR MASTEREX-HANDY 04

MASTEREX-HANDY 04



Combinando lo último en tecnologías de comunicación y la seguridad intrínseca, este móvil dispone de duración telefónica y comunicación de datos permanente, convirtiendo este producto en indispensable en zonas Ex en cuanto a seguridad y efectividad.

El MasterEx-Handy 04 es un robusto teléfono móvil que cuenta con funciones de transmisión de datos y voz en áreas peligrosas. Transmisión rápida de datos vía HSCSD (máximo 43.2 kbit/s en dirección de recepción) y GPRS (máximo 40.2 kbits en dirección de recepción) son dos de las muchas características del MasterEx-Handy 04. El GPRS ofrece un servicio rápido de acceso a internet prácticamente en cualquier lugar donde se esté. Cuenta además con infrarrojos que posibilitan el uso de una PDA y con un mecanismo de apunte de notas en áreas Ex. Lleva integrado navegador WAP (versión 1.2.1) que permite un acceso rápido y fácil del móvil a Internet.

Combining the latest in i.s. and communication technologies, this mobile phone provides both permanent telephonic availability and Data communications, making this product indispensable for safe and effective working in Ex-hazardous areas.

The MasterEx-Handy 04 is a robust mobile phone that provides unparalleled Data and Voice communication functions in the Ex-hazardous area. Fast Data transmission via HSCSD (maximum 43.2 kbit/s in receiving direction) and GPRS (maximum 40.2 kbit/s in receiving direction) are just two of the many features of the MasterEx-Handy 04. With GPRS fast access to mobile internet services is available practically wherever you are. In addition, the infrared interface enables the use of suitable PDA and Notebook devices to be used in Ex-hazardous areas. An integrated WAP browser (version 1.2.1) allows for fast and easy access to the mobile internet.

Ce portable qui est une combinaison du Nec plus ultra en technologie et de la sécurité intrinsèque, dispose d'une durée d'appel et de communication de renseignements permanente, rendant ce produit indispensable dans les zones Ex pour la sécurité et l'efficacité. Le MasterEx-Handy 04 est un portable robuste qui est doté de fonctions de transmission d'informations écrites et orales dans des zones dangereuses. Transmission rapide de renseignements via HSCSD (max 43.2 Kbit/s en envoi et réception) et de GPRS (max. 40.2 Kbit/s en envoi et réception), ce sont deux des multiples caractéristiques du MasterEx-Handy04. Le GPRS offre un service rapide d'accès à Internet, pratiquement en tous lieux. De plus il est doté d'infrarouges ce qui permet l'utilisation d'un PDA avec un dispositif de prise de notes sur zone Ex. Il a un navigateur WAP intégré (version 1.2.1) qui permet un accès rapide et facile du portable à internet.

Funciones:

- Móvil tribanda – comunicación a través de redes sobre los cinco continentes.
- Tecnología Java TM para descargas rápidas de programas.
- GPRS (General Packet Radio Service).
- HSCSD (High Speed Data Transmission).
 - Bluetooth.
 - Fax/modem integrado.
 - Navegador WAP2 1.2.1-
- Configuración controlada por tiempo.
- Almacenamiento de 500 entradas cada una capaz de archivar 3 números de teléfono y texto.
- Pantalla de alta resolución para gráficos y con iluminación a contra luz.
- Pantalla dinámica, ajuste automático de pantalla para una legibilidad óptima.
 - Superficie de contacto infrarroja.
- Control por voz para más de 10 voces.

Functions:

- Triband mobile phone - communication via three networks on five continents.
- JavaTM-Technology for fast download of programmes.
- GPRS (General Packet Radio Service)
- HSCSD (High Speed Data Transmission)
 - Bluetooth
 - Integral faxmodem.
 - WAP2 1.2.1- Browser
- User defined and time controlled profiles.
- Up to 500 telephone book entries each with 3 call numbers and a text area.
- High resolution full-graphic display with backlighting.
- Dynamic display, automatic adjustment of the display for optimum readability.
 - Infrared interface.
- Voice controlled selection facility for up to 10 names.

Fonctions:

- Portable tri-bandes – communication par réseaux sur les cinq continents.
- Technologie Java TM pour le téléchargement rapide de programmes.
- GPRS (General Packet Radio Service)
- HSCSD (High Speed Data Transmission)
 - Bluetooth
 - Faxmodem intégré
 - Navigateur WAP2 1.2.1-
- Configuration contrôlée par temps
- Stockage de 500 entrées chacune capable d'archiver 3 numéros de tel. et de texte.
- Ecran en haute résolution pour des graphiques et un éclairage à contre jour.
- Ecran dynamique, ajustement automatique de l'écran pour une lisibilité optimale.
 - Superficie de contact infrarouge.
- Contrôle vocal pour plus de 10 voix.

COMUNICACIÓN / COMMUNICATION / COMMUNICATION

MASTEREX-HANDY 04



COD

79500

El MasterEx-Handy 04:

Tanto en Europa, Asia, Australia o América, el MasterEx-Handy 04 opera mundialmente con cualquiera de las tres diferentes frecuencias de red y escoge automáticamente la red óptima GSM para todos los continentes.

Datos Ex:

Designación Ex:
Ex 2 G EEx ib IICT4

EC-Certificado de conformidad:

ZELM 02 ATEX 0107

Condiciones estándar:

- MasterEx-Handy 04 para redes GSM (disponible sin tarjeta SIM)
- Cargador de batería LGH 04 - UK Pin
- Funda de cuero
- Batería Ex-AMH 04

Accesorios:

- Estación de cambio de escritorio DCH 9 (sin cargador) (cod. 79518)
- Módulo de batería de recambio Ex-AMH 04 (cod. 79519)
- Cargador de batería LGH 04 - Euro Pin (cod. 79520)

The MasterEx-Handy 04:

Whether in Europe, Asia, Australia or America, the MasterEx-Handy 04 operates worldwide on three different network frequencies and automatically chooses the optimum GSM network on all continents.

Ex-data:

Ex-designation:
Ex 2 G EEx ib IICT4

EC-Certificate of conformity:

ZELM 02 ATEX 0107

Standard delivery:

- MasterEx-Handy 04 for GSM networks (supplied without SIM card)
- LGH 04 battery charger - UK Pin
- Leather case
- Ex-AMH 04 Ex-battery

Accessories:

- Desktop charging station DCH 9 (without charger) (cod. 79518)
- Spare Ex-AMH 04 battery module (cod. 79519)
- LGH 04 battery charger - Euro Pin (cod. 79520)

LE MasterEx-Handy 04:

Tant en Europe, Asia, Australie ou Amérique, le MasterEx-Handy 04 opère mondialement avec n'importe quelle des 3 fréquences de réseau et prend automatiquement le réseau optimal GSM sur tous les continents.

Renseignements Ex:

Désignation Ex:
Ex II 2 G EEx ib IIC T4

EC-Certificat de conformité:

ZELM 02 ATEX 0107

Conditions standards:

- MasterEx-Handy 04 pour réseau GSM (disponible sans carte SIM)
- Chargeur de batteries LGH 04 - UK Pin
- Etui en cuir
- Ex-AMH 04 Ex-batterie

Accessoires:

- Poste de changement d'écriture DCH 9 (sans chargeur) (cod. 79518)
- Module de batterie de rechange Ex-AMH 04 (cod. 79519)
- Chargeur de batteries LGH 04 - Euro (cod. 79520)

| Especificaciones técnicas / Technical specification / Détails techniques | |
|--|-------------------------------|
| Tipo de red / Network type / Type de réseau | Tribanda / Triband / Tribande |
| Redes / Networks / Réseau | GSM 900/ GSM 1800/ GSM 1900 |
| Potencia de transmisión / Transmitter power / Puissance de transmission | ≤2 W / ≤1 W / ≤1 W |
| Rango de temperaturas de operación / Operating temperature range / Températures d'utilisation | 0°C +40°C |
| Rango de temperaturas de almacenamiento / Storage temperature range / Températures de stockage | -5°C +50°C |
| Dimensiones / Dimensions / Dimensions | 129x47x31mm |
| Batería / Power supply / Batterie | Ex-AMH 04 |
| Peso / Weight / Poids | 140g |
| Tiempo de duración encendido / Stand-by time / Durée appareil allumé | max. 360 h |
| Tiempo de comunicación / Talk time / Durée de communication | max. 6 h* |

* El tiempo de operación puede variar en función de la red cogida, de la tarjeta SIM, y de la aplicación.

* Operating time can vary depending on the network settings, SIM cards and the application.

* Le temps de conexión peut varier suivant le réseau choisi, de la carte SIM, et de l'application.



COMUNICACIÓN / COMMUNICATION / COMMUNICATION

RADIOTRANSMISOR INTRÍNSICAMENTE SEGURO MASTEREX-PMR 1000
 INTRINSICALLY-SAFE TWO-WAY-RADIO MASTEREX-PMR 1000
 RADIO-TRANSMETTEUR INTRINSÈQUEMENT SÛR MASTEREX-PMR 1000



MasterEX-PMR 1000

COMUNICACIÓN EN LAS ZONAS EX

La comunicación segura y fiable es un aspecto muy importante en las zonas Ex. Se deben cumplir estrictos requisitos por parte de todos los transmisores de radio, para asegurar una comunicación segura, incluso en largas distancias. El transmisor de radio portátil MasterEx-PMR 1000 se desarrolló específicamente para este propósito. Con la certificación ATEX en protección clase Ex II 2 G Eex ib IICT4 y Ex II 3 D T130°C IP 54, este aparato cumple con las normas más recientes y se puede usar en las zonas 1 y 2, o la 22. La frecuencia de banda desde 446.000 MHz hasta 446.100 MHz se extendió al uso público por ERC tras la publicación de su ERC/DEC (98) 25, 26, 27 el 1 Diciembre de 1998. Todos los aparatos manuales con antena fija que trabajan en ese rango de frecuencias están de acuerdo con la norma autorizada ETS 300296 y se permite su uso legal y sin coste en muchos países europeos. El MasterEx-PMR 1000 cumple las rígidas especificaciones del IP54 y por tanto satisface la alta demanda industrial y proporciona fiabilidad especialmente para aplicaciones en zonas Ex. La máxima potencia de transmisión está limitada a 500 mW ERP, proporcionando un rango de hasta 5 km. Los sistemas de ondas piloto CTCSS y DCS se configuran para codificación analógicas y digitales selectivas. Una variedad de ondas piloto permite al usuario comunicarse dentro de grupos. Todas las funciones de la radio pueden ser fácilmente configuradas vía PC usando el software opcional.

COMMUNICATION IN EX-AREAS

Safe and reliable communication is an important aspect in Ex-hazardous areas. Stringent requirements have to be satisfied by all radio transceivers used, to ensure a safe communication, even over long distances. The MasterEx-PMR 1000 portable radio transceiver was developed specifically for this purpose. Featuring ATEX certification in protection class Ex II 2 G Eex ib IICT4 or Ex II 3 D T130°C IP 54, the device complies with the very latest standards and can be used in Zones 1 and 2, or 22. The frequency band ranging from 446.000 MHz to 446.100 MHz was opened for public use by the ERC with the publication of its decision ERC/DEC(98) 25, 26, 27 dated 1 December 1998. All handheld devices with fixed antenna which operate in this frequency range conform to the ETS 300296 licensing standard and are allowed to be used license- and chargefree in many European countries. The MasterEx-PMR 1000 fulfils the rigid specifications of IP54 and therefore meets the high demand for industrial ruggedness and reliability especially for applications in Ex-hazardous areas. The maximum transmission power is limited to 500 mW ERP giving a range of up to 5 km. The CTCSS and DCS pilot tone systems are configured for selective analogue and digital coding. A variety of pilot tones enables users to communicate within groups. All functions of the radio unit can be easily preconfigured via PC using the optional software kit.

COMMUNICATION DANS LES ZONES EX

La communication sûre et fiable est un aspect très important dans les zones Ex. Elle doit suivre des conditions requises strictes par tous les opérateurs de radio, pour assurer une communication sûre y compris sur des longues distances. Le transmetteur de radio portable MasterEx-PMR 1000 a été spécialement conçu pour ces problèmes. Avec la certification ATEX en protection classe Ex II 2 G Eex ib IICT4 or Ex II 3 D T130°C IP 54, cet appareil remplit les conditions des normes les plus récentes et il peut être utilisé dans les zones 1 y 2, o la 22. La fréquence de 446.000 MHz à 446.100 MHz est étendue à l'utilisation publique ERC suite à la publication de ERC/DEC (98) 25, 26, 27 le 1 Décembre 1998. Tous les appareils à antenne fixe travaillant dans cet éventail de fréquences sont conformes à la norme autorisée ETS 300296 et est permis son utilisation légale sans coût dans beaucoup de pays européens. Le MasterEx-PMR 1000 remplit les dures conditions IP54 il répond à la grande demande industrielle et donne une fiabilité totale pour des applications en zones Ex. La puissance de transmission est limitée a 500 mW ERP, et une distance de 5 km. Les systèmes d'ondes pilotes CTCSS et DCS se configurent pour une codification analogique et digitale sélectives. Une variété d'onde pilote permet à l'utilisateur une communication au sein d'un groupe. Toutes les fonctions de la radio peuvent facilement être configurés via PC en utilisant le software optionnel.

COMUNICACIÓN / COMMUNICATION / COMMUNICATION



COD

79501

MasterEX-PMR 1000

El MasterEx-PMR 1000 es un radiotransmisor para la comunicación inalámbrica en las zonas EX.

- 8 canales
- Llamada DCS selectiva para transmisión y recepción
- Alcance hasta 5 km
- Función de búsqueda
- Aprobado para las zonas EX polvo (zona 22)
- Supresor de ruido de fondo (9 niveles)
- TOT (tiempo límite de transmisión)
- Función ahorro de batería
- Grado de protección IP54

Datos Ex:

Denominación Ex:
EX II 2G EEx ib IICT4
EX II 3D T130°C IP54

Certificado del tipo de examinación:
ZELM 05 ATEX 0271

Equipamiento:

- Unidad de radio MasterEx-PMR 1000
- Pack de baterías-Ex Ex-AM PMR 1000
- Pinza para cinto para el MasterEx-PMR 1000
- Cargador LS PMR 1000
- Unidad de alimentación PS PMR 1000
- Manual de instrucciones

Accesorios opcionales:

- Funda portadora de cuero (cod. 79521)
- Combinación remota altavoz / micrófono Ex-HS 01 (cod. 79522)
- Pack de baterías de repuesto (cod. 79523)
- Set de carga (cod. 79524)
- Software (cod. 79525)

The MasterEx-PMR 1000 is a license and charge-free two-way radio for wireless communication in Ex-hazardous areas.

- 8 channels
- DCS selective call for transmission and reception
- Up to 5 km range
- Scan function
- Approved for dust-Ex-areas (zone 22)
- Squelch tail elimination (9 levels)
- TOT (transmission time limit)
- Battery save function
- 1P54 protection rating

Ex-data:

Ex-designation:
EX II 2G EEx ib IICT4
EX II 3D T130°C IP54

Type examination certificate:
ZELM 05 ATEX 0271

Standard delivery:

- Radio unit MasterEx-PMR 1000
- Ex-battery pack Ex-AM PMR 1000
- Belt clip for MasterEx-PMR 1000
- Charger LS PMR 1000
- Power supply unit PS PMR 1000
- Operating instructions

Optional accessories:

- Leather carrying case (cod. 79521)
- Remote speaker / microphone combination Ex-HS 01 (cod. 79522)
- Spare battery pack (cod. 79523)
- Charging Set (cod. 79524)
- Software kit (cod. 79525)

Le MasterEx-PMR 1000 est un radio-transmetteur pour la communication inalámbrica dans les zones EX.

- 8 canaux
- Appel DCS sélective pour la transmission et la réception
- Couverture jusqu'à 5 km
- Fonction de recherche
- Approuvé pour les zones EX poussière (zone 22)
- Suprésion de bruit de fond (9 niveaux)
- TOT (temps limite de transmission)
- Fonction d'économie d'énergie
- Type de protection IP54

Renseignements Ex:

Désignation Ex:
EX II 2G EEx ib IICT4
EX II 3D T130°C IP54

Certificat du type de test:
ZELM 05 ATEX 0271

Equipement:

- Unité de radio MasterEx-PMR 1000
- Pack de piles-Ex Ex-AM PMR 1000
- Pince de ceinture pour le MasterEx-PMR 1000
- Chargeur LS PMR 1000
- Unité d'alimentation PS PMR 1000
- Manuel d'instructions

Accessoires options:

- Etui en cuir (cod. 79521)
- Possibilité Haut.-parleur / microphone Ex-HS 01 (cod. 79522)
- Pack de piles de rechange (cod. 79523)
- Set de charge (cod. 79524)
- Software (cod. 79525)

Especificaciones técnicas / Technical specification / Détails techniques

| | |
|---|---|
| Rango de frecuencia / Frequency range / Eventail de fréquences | 446.00625 - 446.09375 MHz |
| Sensibilidad / Sensitivity / Sensibilité | approx. 0,25 µV a 12 dB SINAD |
| Anchura de canal / Channel spacing / Longueur de canal | 12,5 kHz |
| Max. potencia de transmisión / Max. transmission power / Max. Puissance de transmission | 500 mW ERP |
| Protección IP / IP protection / Protection IP | IP 54 |
| Batería / Battery / Batterie | Recargable de litio / Rechargeable lithium ion Rechargeable de lithium |
| Temp. ambiente / Ambient temp / Temp. ambiante | -20°C ... +50°C |
| Autonomía / Operating time / Autonomie | approx. 12 horas (90% en apoyo, 5%TX, 5%RX) |
| Peso / Weight / Poids | approx. 430g |



MEDICIÓN / MEASURING / MESURE

MEDIDOR DE TEMPERATURA SIN CONTACTO MASTEREX-MP 4
 INTRINSICALLY-SAFE NON-CONTACT TEMPERATURE METER MASTEREX-MP 4
 LE THERMOMÈTRE À DISTANCE SANS CONTACT MASTEREX-MP 4



MasterEX-MP 4

El equipo MasterEx-MP 4 para mediciones de temperatura sin contacto intrínsecamente seguro es un robusto instrumento fácil y manejable en áreas peligrosas.

The intrinsically-safe non-contact temperature measuring equipment MasterEx-MP 4 is a robust yet exceedingly handy and easy to use instrument for temperature measuring in hazardous areas.

Le thermomètre à distance MasterEx-MP 4 intrinsèquement sécuritaire est un robuste et très petit appareil manuable pour mesurer les températures dans des zones à risque.

Especificaciones técnicas / Technical specification / Détails techniques

| | |
|---|--|
| Rango de temperatura / Temperature range / Echelle de température | -18°C - +260°C (0°F - +500°F) |
| Resolución / Resolution / Précision de la mesure | 0.5°C (1.0 F) |
| Señalización del objetivo / Target sighting / Pointage de la cible | laser (tipo II / class II) |
| Precisión (a 23°C) / Accuracy / Exactitude | -18°C...-1 °C ±3°C - 1 °C...+260°C ±2°C or ±2% |
| Repetibilidad / Repeatability / Répétabilité | ±2°C or 2% |
| Tiempo de Respuesta / Response time / Temps de réponse | 500ms |
| Emisibilidad / Emissivity / Emission | ajuste 0,95 / preset 0,95 |
| D/L óptico / Optics D/L / Optique D/L | = 0,166 |
| Respuesta espectral / Spectral response / Réponse spectrale | 7 - 18 µm |
| Rango ambiental de operación / Ambient operating range / Champ d'action ambient | 0°C...+50°C |
| Rango de temperaturas de almacenamiento / Storage temperature range / Température de stockage | -20°C... +65°C |
| (sin batería) / (without battery) / (sans piles) | |
| Humedad relativa / Relativ humidity / Humidité relative | 10 - 95% (>30°C) non condensing / sin condensación / sans condensation |
| Alimentación de energía / Power supply / Puissance des batteries | 9V alkaline - IEC 6LR61 |
| Dimensiones / Dimensions / Dimensions | 152x101x38mm |
| Peso / Weight / Poids | ~200g |

MEDICIÓN / MEASURING / MESURE



COD

79502

MasterEX-MP 4

Beneficios de la medición sin contacto

Aumenta la seguridad cuando se determina la temperatura a objetos en movimiento o sin antenas. Significa que el calor por fricción no afecta a la medición. No deja marcas ni imperfecciones al ser el objeto medido.

Tiempo de respuesta

Rápida y exacta. La respuesta pirométrica que emite energía es de 20 a 1000 veces más rápida que los termómetros tradicionales de contacto directo.

Para mediciones de temperatura sin contacto y monitorización de temperatura en áreas peligrosas

- Gran exactitud
- Operaciones simples
- Rápida respuesta
- Señalización del objeto por láser
- Medida desde la Zona 1 hasta la Zona 0

Datos Ex:

Designación Ex:
EX II2G EEx ia IICT4
EC-Certificado de continuidad:
TÜV 00 ATEX 1580 X

Bajo mantenimiento y no agresivo

El procedimiento no afecta a la temperatura del objeto que está siendo medido.

- El que no haya contacto del detector significa que no hay riesgo por contacto.
- No es necesario fijar o sujetar puntos sobre el objeto o el equipo.

Para alcanzar objetivos difíciles y objetos en movimiento

- La óptica del pirómetro se dirige al objeto que va a medir y con la señal de láser es posible apuntar objetos pequeños y distantes.

- Los materiales peligrosos y agresivos pueden ser medidos con seguridad sin miedo a dañar el equipo. El tamaño compacto del pirómetro permite que se pueda usar incluso en posiciones de mucha dificultad, sólo es necesario que exista una línea clara desde la señal al objetivo. Con la medición por contacto directo la capacidad de calor o la conducción de calor del objeto puede transferir un escaso flujo de calor al aparato de medida.

The benefits of non-contact measurement

Increased safety when determining the temperature of fast moving objects. No antennas mean that frictional heat cannot affect the measurement. No mark or blemish is left on the object being measured.

Response time

Fast and accurate. Pyrometers respond to emitted energy and are around 20 to 1000 times quicker than traditional direct contact thermometers.

For non-contact temperature measurement and monitoring of temperature processes in Ex-hazardous areas

- High accuracy
- Simple operation
- Quick response time
- Laser target sighting
- Measure from Zone 1 into Zone 0

Ex-data:

Ex designation:
EX II2G EEx ia IICT4
EC-Certificate of Conformity:
TÜV 00 ATEX 1580 X

Low maintenance and non invasive

The temperature of the object being measured is not affected by the procedure.

- Non contact of the detector means no wear and tear.
- No fixing or fastening points required on either the object or equipment.

Hard to reach objects and moving materials

- The optics of the pyrometer are aimed at the object to be measured and with the laser sighting it is possible for both small and distant objects to be targeted.

- Hazardous and aggressive materials can be safely measured - and without fear of damaging the equipment. The compact size of the pyrometer allows it to be used in even the most awkward positions, with only a clear line of sight to the target area being required. With direct contact measurement, poor heat conduction or heat capacity of the object can prevent insufficient heat flow to a measuring device.

Les bénéfices d'un appareil de mesure à distance

Il augmente la sécurité lors de la mesure d'objets mobiles. Les antennes n'empêchent pas la prise de température. Pas de marque, ni de défaut ne peuvent gêner la mesure.

Temps de réponse

Rapide et précise. Les pyromètres répondent à l'énergie dégagée et sont plus rapides entre 20 à 1000 fois que les traditionnels thermomètres de contact.

Pour une mesure de température à distance en évitant le contact avec l'appareil de test dans les zones à risques

- Grande exactitude
- Simple d'utilisation
- Réponse rapide
- Pointage de la cible par laser
- Mesure de la zone zone 1 à la zone 0

Ex-data:

Ex designation:
EX II2G EEx ia IICT4
EC-Certificat de conformité:
TÜV 00 ATEX 1580 X

Petit entretien et sans intervention

La température de l'objet étant mesurée elle n'est pas affectée.

- L'absence de contact fait éviter l'usure et les accrocs.
- Aucune fixation n'est nécessaire pour chacun des objets ou équipements.

Difficulté d'atteindre des objets ou des matériaux en mouvement

- Les optiques du pyromètre pointent l'objet à mesurer et avec la vise laser il est possible de pointer des objets petits et distants.

- Des matériaux à risque peuvent être mesurés en sécurité sans dommage pour l'équipement. La forme compacte du pyromètre lui permet une utilisation dans les positions les plus inconfortables avec une visée claire. Avec une mesure par contact, la faible chaleur de conduction ou de potentiel de l'objet peut empêcher une bonne mesure.



MEDICIÓN / MEASURING / MESURE

INDICADOR ULTRASONICO DE ESPESOR DE PARED INTRÍNSECAMENTE SEGURO
 MASTEREX 1071 / INTRINSICALLY-SAFE ULTRASONIC WALL THICKNESS GAUGE
 MASTEREX 1071 / CALCULATEUR ULTRASONIQUE D'ÉPAISSEUR DE PAROI INTRINSÈ-
 QUEMENT SÛR MASTEREX 1071



With the MasterEx 1071 measurements of wall thicknesses can be made quickly and accurately in the range of 0,7 to 400 mm.

There are three different probes available to cover this wide measuring range, each of which can be easily and conveniently changed inside the hazardous area.

- standard probe: 1,5 to 250 mm
- mini probe: 0,7 to 25 mm
- low frequency probe: 5 to 400 mm

Due to its compact size and operating time of over 200 hours this easy to use instrument is essential whenever the continuous supervision of minimum wall thicknesses is required. For example, it is possible to check the thickness of protective coats or for the erosion of pipe or tank walls even while the plant is operating. By using the limit value guides, minimum and maximum values can be set and are registered by an audible signal.

The calibration functionality of the Instrument means that adjustments can be made to compensate for the type of material being measured, this is done by one of two ways:

1. entering the sound velocity of the corresponding material
2. measuring a material with known thickness and adjusting the instrument to that reference.

These adjusted parameters then stay in the memory even when switching off the instrument. Display resolution and sensitivity are also fully adjustable and as with all the other functions, are easily selected from the straightforward menu.

MasterEX-1071

Con el MasterEx-1071 las medidas del espesor de las paredes pueden realizarse de forma rápida y precisa en el rango de 0,7 a 400 mm.

Hay 3 sondas diferentes disponibles para cubrir este amplio rango de medidas, cada una de las cuales puede ser cambiada fácilmente y según convenga dentro de la zona de peligro.

- Sonda standard: de 1,5 a 250 mm
- Mini sonda: de 0,7 a 25 mm
- Sonda de baja frecuencia: de 5 a 400 mm

Debido a su compacto tamaño y su autonomía de alrededor de 200 horas, este sencillo instrumento es esencial siempre que se requiera una continua supervisión del espesor de paredes delgadas. Así por ejemplo, es posible comprobar el espesor de capas de protección o la erosión de tuberías o paredes de depósitos incluso cuando la planta está funcionando. Usando las guías de valores límite, el mínimo y el máximo pueden ser fijados y se registran mediante una señal auditiva.

La función de calibración del instrumento significa que pueden hacerse ajustes para compensar el tipo de material que está siendo medido, haciéndose esto de una de estas 2 formas:

1. introduciendo la velocidad del sonido del material correspondiente.
2. midiendo un material de grosor conocido y ajustando el instrumento a esa referencia.

Estos parámetros ajustados permanecen en la memoria incluso cuando se apaga el instrumento. La resolución y sensibilidad de la pantalla también son completamente ajustables y como las otras funciones, son fácilmente seleccionables desde un sencillo menú.

Avec le MasterEx 1071 les calculs d'épaisseur de paroi peuvent être réalisés rapidement et précisément de 0,7 à 400 mm.

Il existe 3 sondes différentes pour calculer toutes les épaisseurs de paroi, chacune d'elles peuvent être changée facilement à souhait dans la zone et ce sans danger.

- Sonde standard: de 1,5 à 250 mm
- Mini sonde: de 0,7 à 25 mm
- Sonde en basse fréquence: de 5 à 400 mm

Grâce à sa taille compacte et son autonomie de 200 heures approx., cet instrument simple est essentiel pour toutes mesures continues de parois minces. De cette façon, il est possible de vérifier l'épaisseur de couches de protection ou l'usure de tubes ou de parois de citernes, même en période de travail. En utilisant les tables de valeurs limites, le minimum et le maximum peuvent être fixés et sont enregistrés par signal auditif.

La fonction de mesure de l'instrument indique que des réglages peuvent se faire pour compenser le type de matériau qui est mesuré, le faisant de deux façons:

1. En introduisant la vitesse de son du matériau correspondant
2. En mesurant un matériau d'épaisseur connue et en ajustant l'instrument à cette référence

Par la suite, les paramètres restent enregistrés en permanence dans en mémoire, même en éteignant l'appareil. La résolution et la sensibilité de l'écran sont totalement réglables et les autres fonctions sont facilement sélectionnables, à partir de menu très simple.

MEDICIÓN / MEASURING / MESURE



MasterEX-1071

Para comprobar el grosor de paredes delgadas de tuberías y depósitos en zonas Ex.

Rangos:

- Sonda standard: de 1,5 a 250 mm
- Mini probe: de 0,7 a 25 mm
- o sonda de baja frecuencia: de 5 a 400 mm

Las sondas pueden ser cambiadas en las zonas Ex
Precisión $\pm 0,05$ mm

Funciones:

- Guías de valores límite y regulación
- Sensibilidad ajustable
- Fácil de usar
- Modo de ahorro de energía

Datos Ex:

Denominación Ex:
Ex II 2 (1) G EEx ia IIC T4
EC-Certificado de Conformidad:
PTB 97 ATEX 2231 X

Equipamiento:

Echometer 1071-Ex Incl. pilas, estuche y 100 ml de gel de acople de ultrasonidos

Opciones & Accesorios:

- Sonda Standard DSE 10,416 PB 4 (cod. 79526)
- Acoplamiento para la sonda standard (cod. 79527)
- Películas Vulcollan (10 pcs.) para DSE 10,41 6 PB 4 (cod. 79528)
- Sonda de baja frecuencia DSE 18125 PB 1,5 (cod. 79529)
- Acoplamiento para la sonda de baja frecuencia (cod. 79530)
- Películas Vulcollan (10 pcs.) para DSE 18125 PB 1,5 (cod. 79531)
- Sonda Mini DSE 4,214 PB 8 (cod. 79532)
- Películas Vulcollan (10 pcs.) para DSE 4,214 PB 8 (cod. 79533)
- Gel de acople de ultrasonidos ECHOTRACE 500 ml. (cod. 79534)

For checking minimum wall thickness of pipes and tanks in Ex-hazardous areas.

Ranges:

- Standard probe: 1,5 to 250 mm o mini probe: 0,7 to 25 mm
- Low frequency probe: 5 to 400 mm

Probes can be changed in Ex-zones Accuracy $\pm 0,05$ mm

Functions:

- Limit value guides and monitoring
- Adjustable sensitivity
- Easy to use
- Energy saving mode

Ex-data:

Ex designation:
Ex II 2 (1) G EEx ia IIC T4
EC-Certificate of conformity:
PTB 97 ATEX 2231 X

Standard delivery:

Echometer 1071-Ex Incl. primary cells, case and 100 ml of ultrasound couplant gel

Options & Accessories:

- Standard probe DSE 10,416 PB 4 (cod. 79526)
- Handle-collar for standard probe (cod. 79527)
- Vulcollan films (10 pcs.) for DSE 10,41 6 PB 4 (cod. 79528)
- Low frequency probe DSE 18125 PB 1,5 (cod. 79529)
- Handle-collar for low frequency probe (cod. 79530)
- Vulcollan films (10 pcs.) for DSE 18125 PB 1,5 (cod. 79531)
- Mini probe DSE 4,214 PB 8 (cod. 79532)
- Vulcollan films (10 pcs.) for DSE 4,214 PB 8 (cod. 79533)
- ECHOTRACE ultrasound couplant gel 500 ml. (cod. 79534)

Pour tester les épaisseurs de parois fines des tubes et des cuves en zones Ex.

Catégories:

- Sonde standard: de 1,5 à 250 mm
- Mini sonde: de 0,7 a 25 mm
- o sonde en basse fréquence: de 5 a 400 mm

Les sondes peuvent être changées en zone Ex
Précision $\pm 0,05$ mm

Fonctions:

- Echelles de valeurs limites et régulation
- Sensibilité ajustable
- Utilisation aisée
- Mode d'économie d'énergie

Renseignements Ex:

Désignation Ex:
Ex II 2 (1) G EEx ia IIC T4
EC-Certificat de conformité:
PTB 97 ATEX 2231 X

Equipment:

Echometer 1071-Ex Incl. piles, étui et 100 ml de gel de raccord des ultrasons

Options & Accessoires:

- Sonde Standard DSE 10,416 PB 4 (cod. 79526)
- Raccord pour la sonde standard (cod. 79527)
- Pellicules Vulcollan (10 pcs.) pour DSE 10,41 6 PB 4 (cod. 79528)
- Sonde de basse fréquence DSE 18125 PB 1,5 (cod. 79529)
- Raccord pour la sonde en basse fréquence (cod. 79530)
- Pellicules Vulcollan (10 pcs.) pour DSE 18125 PB 1,5 (cod. 79531)
- Mini sonde DSE 4,214 PB 8 (cod. 79532)
- Pellicules Vulcollan (10 pcs.) pour DSE 4,214 PB 8 (cod. 79533)
- Gel de raccord des ultra-sons ECHOTRACE 500 ml. (cod. 79534)

Especificaciones técnicas / Technical specification / Détails techniques

| | |
|---|---|
| Clase de protección / Ingress protection / Type de protection | IP54 |
| Dimensiones / Dimensions / Dimensions | 120x65 x25 mm |
| Peso / Weight / Poids | 150 g |
| Temperatura de trabajo / Operating temperature / Température de travail | -10°C - +40°C |
| Temperatura de almacenaje / Storage temperature / Température de stockage | -20°C- +60°C (sin pilas / without batteries sans piles) |
| Alimentación / Supply / Alimentation | 2 x pilas / batteries / piles AA - IEC LR6 |
| Autonomía / Working time / Autonomié | 200 horas de continuo funcionamiento 1-2 años de stand-by / 200 hours continuous operation 1-2 years stand-by / 200 heures en continu fonctionnement 1-2 ans de stand-by |
| Instrumento / Instrument / Instrument | zone 1 |
| Sondas / Probes / Sondes | zone 0 |
| Gel de contacto / Contact gel / Gel de contact | Perfecta conexión entre el sensor y el material Perfect connection between sensor and material Connexion parfaite entre le capteur et le matériau |
| Película de Vulcollan / Vulcollan film / Pellicule de Vulcollan | Evita desgastar la sonda si se usa en superficies ásperas / Prevents wear of probe if it is used on rough surfaces / Il évite l'usure de la sonde s'il est utilisé sur des superficies avec des aspérités |



MEDICIÓN / MEASURING / MESURE

TESTER MAGNÉTICO INTRÍSECAMENTE SEGURO MASTEREX MAGNET 12
 INTRINSICALLY SAFE MAGNET PROBE MASTEREX MAGNET 12
 TESTEUR DE MAGNÉTISME INTRINSÈQUEMENT SÛR MASTEREX MAGNET 12

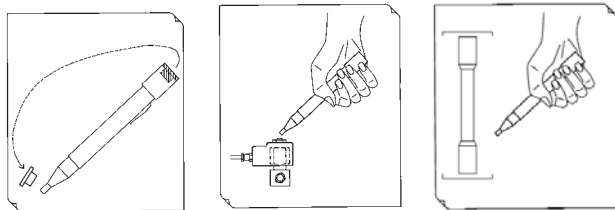
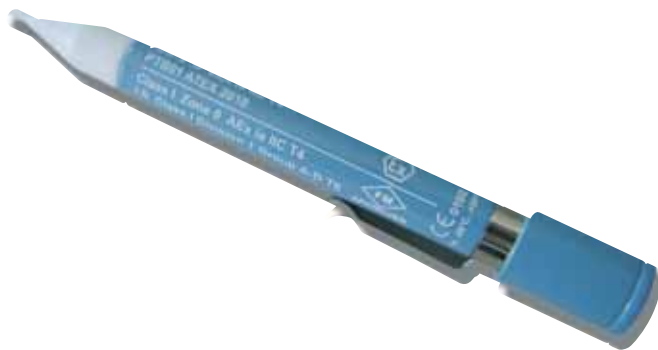

MasterEx Magnet 12 is a pen-sized magnet probe, designed to detect magnetic fields in hazardous areas. Within seconds it is possible to detect whether or not a solenoid valve is electrically activated.

Connection to electronic circuitry or opening of terminal boxes is rendered unnecessary.

The highly sensitive probe point of the MasterEx Magnet 12 only needs to be brought near the coil of a solenoid valve, if the probe shows a red light this indicates that the magnet is activated. In the same manner tests can be carried out on flowmeters or any other equipment that is working magnetically, even when located in hazardous areas.

The MasterEx Magnet 12 comes with an integral test magnet that is securely fitted in such a way that it cannot be easily lost. Using this magnet, tests can be carried out to establish the working state of both unit and batteries.

After any check the MasterEx Magnet 12 will automatically switch off if it is no longer being used. This ensures a long battery life.

The clip attached to the instrument's side secures it from accidental loss and allows the maintenance engineer to easily carry it at all times.

MasterEX MAGNET 12

MasterEx Magnet 12 es un medidor magnético tamaño lápiz, diseñado para detectar campos magnéticos en áreas peligrosas. En pocos segundos es capaz de detectar cualquier solenoide que esté eléctricamente activada.

No es necesario una conexión al circuito eléctrico o abrir una caja de terminales.

La alta sensibilidad del punto del tester de MasterEx Magnet 12 provoca que sólo con acercarse a la bobina del solenoide, si ésta muestra una luz roja, indica que el campo magnético está activado. De la misma manera esta prueba se puede efectuar cerca sobre fluxómetros u otros equipamientos que trabajen magnéticamente, incluso cuando estén localizadas en áreas peligrosas.

El MasterEx Magnet 12 viene integrado con un imán de seguridad para que no pueda ser perdido con facilidad. Usando este imán, la prueba se puede efectuar para conocer el estado de trabajo de la unidad y de las baterías.

Después de cualquier chequeo el MasterEx Magnet 12 se apagará automáticamente si no es utilizado durante un tiempo. Esto asegura una larga vida de las baterías.

El clip incluido en un lado del aparato lo asegura por si hay pérdidas accidentales y permite al ingeniero llevarlo todo el tiempo con facilidad.

Magnet-Ex 12 est un mesureur de magnétisme de la grandeur d'un stylo, dessiné pour détecter des champs magnétiques dans des zones dangereuses. En peu de secondes il est capable de détecter quelconque solénoïde qui est activé électriquement.

Il n'y a pas besoin de connexion au circuit électrique ou d'ouvrir le coffret de terminaux.

La grande sensibilité de la pointe du testeur MasterEx Magnet 12 permet de détecter à l'approche de la bobine du solénoïde, par l'allumage d'une lumière rouge, que le champ magnétique est activé. De la même manière ce test peut s'effectuer près d'un fluxomètre ou d'autres équipements qui travaillent magnétiquement y compris quand ils sont dans des zones dangereuses.

El MasterEx Magnet 12 est fourni avec un aimant de sécurité intégré pour qu'il ne se perde pas facilement. En utilisant cet aimant, le test peut s'effectuer pour connaître l'état de travail de l'unité et des batteries.

Après tout contrôle le MasterEx Magnet 12 s'éteindra automatiquement s'il n'est pas utilisé durant un certain temps. Cela assure une meilleure durée de vie aux piles.

Le clip du côté de l'appareil est une sécurité contre la perte et permet à l'utilisateur de le porter facilement.

MEDICIÓN / MEASURING / MESURE

MasterEX MAGNET 12

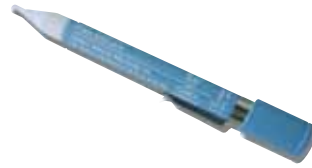

COD

79504

Para solenoides, transformadores, fluxómetros, relés en áreas peligrosas.

Propiedades:

- Alta sensibilidad
- No es necesario contacto con el objeto
- Resistente a la suciedad
- Indicador óptico

Datos Ex:

Designación Ex:
EX II 2G EEX ia IICT4
EC-Certificado de Conformidad:
PTB 01 ATEX 2018

For testing solenoid valves, relays, transformers and flow-meters in Ex-hazardous areas.

Properties:

- Highly sensitive
- No contact with test object required
- Resistant to dirt
- Indication: optical

Ex-data:

Ex designation:
EX II 2G EEX ia IICT4
EC-Certif cate of Conformlty:
PTB 01 ATEX 2018

Pour des solénoïdes, transformateurs, fluxomètres, réseaux dans des zones dangereuses.

Propriétés:

- Haute sensibilité
- Le contact avec l'objet n'est pas nécessaire
- Résistant à la saleté
- Indicateur: optique

Renseignements Ex:

Désignation Ex:
EX II 2G EEX ia IICT4
EC-Certificat de conformité:
PTB 01 ATEX 2018

Especificaciones técnicas / Technical specification / Détails techniques

| | |
|---|--|
| Campos magnéticos detectables / Detectable magnetic fields / Champs magnétiques détectables | alternos, directos, continuos / alternating, direct and permanent fields / alternés, directs, continus |
| Detección / Detection / Détection | no hay contacto con el objeto / no contact with test object required pas de contact avec l'objet |
| Indicación / Indication / Indication | óptica: LED / optical, built-in LED / Optique LED |
| Alimentación de energía / Power supply / Alimentation d'énergie | 2 baterías estándar AAA de acuerdo al IEC LR03, NiCd bat. recargables / 2 x standard batteries AAA according to IEC LR03 or NiCd rechargeable batteries 2 Piles standards AAA conforme á IEC LR03, NiCd bat. rechargeables |
| Temperatura de Trabajo / Working temperature / Température de travail | -20°C ... +50°C |
| Temperatura de almacenamiento / Storage temperature / Température de stockage | -40°C ... +60°C |
| Clase de protección / Ingress protection / Type de protection | IP 54 |
| Material de la carcasa / Casing material / Matière de la coque | metal/punto de prueba plástico / metal/plastic probe point metal/pointe de test plastique |
| Dimensiones / Dimensions / Dimensions | 150xØ18mm |
| Peso / Weight / Poids | 60g (baterías incluidas / batteries included / piles incluses) |



MEDICIÓN / MEASURING / MESURE

TESTER DE CONTINUIDAD INTRÍNSECAMENTE SEGURO MASTEREX-DT 12
 INTRINSICALLY-SAFE CONTINUITY TESTER MASTEREX-DT 12
 TESTEUR DE CONTINUITÉ MASTEREX-DT 12 INTRINSÈQUEMENT SÛR



MasterEX-DT 12

El MasterEx-DT 12 es un robusto medidor manual de continuidad intrínsecamente seguro para ambientes Ex. Los componentes electrónicos están insertados en la carcasa del palpador, lo que permite que ambas manos estén libres para llevar a cabo la prueba.

La combinación de indicaciones ópticas y acústicas permite usarlo incluso en ambientes ruidosos.

The MasterEx-DT 12 intrinsically-Safe continuity tester is a handy and robust testing device for use in Ex-hazardous areas. The electronics are housed in the test probe, which means that both hands are free to be able to carry out the test operation.

The combination of optical and acoustic indication allows usage even in noisy environments.

Le MasterEX-DT 12 testeur de continuité de courant, intrinsèquement sécuritaire, est un testeur manuable et robuste pour les zones à risqué. L'électronique est logé dans le testeur, ce qui signifie que les deux mains suffisent pour réaliser l'opération de test.

La combinaison des indications acoustiques et visuelles permet l'usage dans un environnement bruyant.

Especificaciones técnicas / Technical specification / Détails techniques

| | |
|---|---|
| Temperatura de trabajo / Working temperature / Température de service | -20°C ... +50°C |
| Resistencia / Resistance / Résistance | 10Ω - 450Ω |
| Test de inductividad / Inductivity test / Test d'induction | 10mH- 1H |
| Test de capacidad / Capacity test / Test de capacité | 0.5μF- 1000μF |
| Test de diodo / Diode test / Test de diode | 2 secciones de diodo / 2 diode sections 2 morceaux de diode |
| Inductividad máx. externa / Max. external inductivity / Induction externe maximum | 1H |
| Capacidad máx externa / Max. external capacity / Capacité maximum externe | 1000F |
| Máx. error de corriente de salida / Max. error output flow I_o / Erreur maximum de debit de courant | 5mA |
| Max. error de voltaje de salida / Max. error output voltage U_o / Erreur max de debit de voltage | 3.3V |
| Resist. Máx. de voltaje fuera de zona Ex / Max. external voltage resistance outside of ex-zone Retour maximum de voltage extérieur de la Ex-zone | $U_m = 420V_{eff}$ |
| Duración de la operación / Duration of operation / Durée de l'opération. | approx. 20h (continuo / continuous / continue) |
| Lectura visual / Visual readout / Lecture visuelle | 4 x LED (en el medidor / in test probe dans la sonde test) |
| Lectura acústica / Acoustic readout / Lecture acoustique | altavoz / loudspeaker / haut-parleur |
| Dimensiones del medidor / Test probe dimensions / Dimensions de l'appareil de test (Minus Pol) | 50x 180 mm (l x d) |
| Altura / Overall length / Longueur | 1,40 m (de palpador a palpador / test probe to test probe / de la source à la sonde) |
| Peso / Weight / Poids | approx. 200g (baterías incluidas / batteries included / piles incluses) |
| Alimentación de energía / Power supply / Alimentation d'énergie | 2 x LR03 - IEC |

MEDICIÓN / MEASURING / MESURE



MasterEX-DT 12

Tester de continuidad con indicaciones acústicas y ópticas para probar rápidamente la continuidad eléctrica en áreas EX.

Condiciones estándar:

- MasterEx-DT 12
- 2 tapas protectoras
- 2 x LR03 (AAA) baterías

Accesorios:

- Tapas protectoras (cod. 79535)
- Batería de recambio LR03(AAA) (cod. 79536)

Aplicaciones:

- Test de cableado y contactos eléctricos
- Test de resistencia
- Test de capacidad
- Test de inductividad
- Establecer la dirección en la que transmiten los semiconductores.

Datos Ex:

Designación Ex:
Ex 2 G EEx la IICT4

EC-Certificado de Conformidad:
TUV 03 ATEX 2120

Continuity tester with acoustic and optical indication for fast testing of electrical continuity in Ex-hazardous areas.

Standard delivery:

- MasterEx-DT 12
- 2 protective caps
- 2 x LR03 (AAA) batteries

Accessories:

- Protective caps (cod. 79535)
- Spare battery LR03(AAA) (cod. 79536)

Application:

- Testing of wiring and electrical contacts
- Testing of resistances
- Testing of capacities
- Testing of inductivities
- Establishing the transmitting direction of semi-conductors.

Ex-data:

Ex-designation:
Ex 2 G EEx la IICT4

EC-Certificate of Conformity:
TUV 03 ATEX 2120

Testeur de continuité de courant avec indicateur d'acoustique et d'optique pour un rapide test de continuité de courant dans les aires á risque.

Livraison standard:

- MasterEx-DT 12
- 2 couvercles de protection
- 2 x LR03 (AAA) piles

Accessoires:

- Couvercles de protection (cod. 79535)
- Piles de rechange LR03 (AAA) (cod. 79536)

Application:

- Test de montage et de contacts électriques
- Test de résistance
- Test de capacité
- Test d'inductions
- Etablissement de la direction de transmission des semi-conducteurs.

Renseignements Ex:

Désignation Ex:
Ex 2 G EEx la IICT4

EC-Certificat de conformité:
TUV 03 ATEX 2120

EGGA *Master* S.A.
ART IN INNOVATION



ILUMINACIÓN / ILLUMINATION / ECLAIRAGE

LINTERNA LED DE BOLSILLO INTRÍNSECAMENTE SEGURA MASTEREX LITE LED 30
INTRINSICALLY-SAFE LED POCKET TORCH MASTEREX LITE LED 30
LAMPE DE POCHE LED INTRINSÈQUEMENT SÛR MASTEREX LITE LED 30

MasterEX LITE LED 30

Compacta y de fácil manejo, la MasterEx Lite LED 30 es ideal como luz de inspección en las zonas Ex.

Compact and easy to handle, the MasterEx Lite LED 30 is ideal for inspection lighting in Ex-hazardous areas.

Compacte et facile d'usage, la MasterEx Lite LED 30 est idéale comme lumière d'inspection en zone Ex.

| Especificaciones técnicas / Technical specification / Détails techniques | |
|--|---|
| Temperatura ambiente Ta / Ambient temperature Ta Température ambiante Ta | -20°C... +50°C |
| Temperatura de almacenamiento / Storage temperature Température de stockage | -20°C... +60°C |
| Autonomía / Operating time / Autonomie | 80 h |
| Suministro eléctrico / Power supply Équipement électrique | 3 x LR 1 como por IEC (baterías verificadas) / 3 x LR 1 as per IEC (type proofed batteries) / 3 x LR 1 comme pour IEC (piles vérifiées) |
| Peso / Weight / Poids | approx. 160 g (con baterías / with batteries avec piles) |
| Dimensiones / Dimensions / Dimensions | 140x26mm(Lxd) |

La MasterEx Lite LED 30 es una linterna LED compacta, robusta y de fácil manejo, certificada de acuerdo con ATEX para su uso en las zonas EX clasificadas como Zona 2, 1 y 0 además de la 22 y la 21.

- Autonomía: 80 horas
- Robusta carcasa metálica
- 3-LED's con reflectores
- Vida estimada del LED de hasta 100.000 horas de funcionamiento
- Certificada para su uso en las Zonas- Ex 22 y 21 (polvo)

Datos Ex:

Denominación-Ex:
Ex II 1G EEx ia IIC T4
Ex II 2D T90°C IP52

EC-Certificado de conformidad:
ZELM 02 ATEX 0104

Equipamiento:

- MasteEx Lite LED 30
- Baterías
- Estuche de nylon
- Correa para la muñeca

Accesorios:

- Batería de repuesto LR1 (cod. 79537)
- Funda de cuero (cod. 79538)

The MasterEx Lite LED 30 is a compact, robust and easily operated LED-Torch, certified in accordance with ATEX for use in Ex-hazardous areas classified as Zone 2,1 and 0 as well as 22 and 21.

- Operating time 80 hours
- Robust metal housing
- 3-LED's with reflectors
- LED life expectancy up to 100.000 operating hours
- Certified for use in Dust Ex-Zones 22 and 21

Ex-data:

Ex-designation:
Ex II 1G EEx ia IIC T4
Ex II 2D T90°C IP52

EC-Certificate of conformity:
ZELM 02 ATEX 0104

Standard delivery:

- Lite-Ex LED 30
- Batteries
- Nylon case
- Wrist strap

Accessories:

- Spare battery LR 1 (cod. 79537)
- Leather holster (cod. 79538)

La MasterEx Lite LED 30 est une lampe LED compacte, robuste et facile d'utilisation, certifiée conforme à ATEX pour son usage dans les zones EX classifiées comme zone 2, 1 y 0 en plus de la 22 et la 21.

- Autonomie 80 heures
- Carcasse métallique robuste
- 3-LED's avec réflecteur
- Durée de vie estimée du LED jusqu'à 100.000 heures de fonctionnement
- Certifiée pour une utilisation en zones- Ex 22 y 21 (poussière)

Renseignements Ex:

Désignation Ex:
Ex II 1G EEx ia IIC T4
Ex II 2D T90°C IP52

EC-Certificat de conformité:
ZELM 02 ATEX 0104

Équipement:

- MasteEx Lite LED 30
- Piles
- Etui en nylon
- Courroie pour poignée

Accessoires:

- Pile de rechange LR1 (cod. 79537)
- Etui en cuir (cod. 79538)

ILUMINACIÓN / ILLUMINATION / ECLAIRAGE

LINTERNA LED INTRÍNSECAMENTE SEGURA MASTEREX LITE PL 30
INTRINSICALLY-SAFE LED TORCH MASTEREX LITE PL 30
LAMPE LED INTRINSÈQUEMENT SÛR MASTEREX LITE PL 30
MasterEX LITE PL 30

La linterna LED MasterEx Lite PL 30 proporciona unas prestaciones sin igual.

El LED de 3 vatios está alimentado por 3 pilas LR14 que le proporcionan muchas horas de autonomía. Con un gran ratio de protección: IP 65, su carcasa polimérica y anti-estática está ergonómicamente diseñada para un agarre seguro y confortable incluso en las más difíciles condiciones. Encender la linterna no podría ser más fácil: simplemente hay que girar su cabeza. Este innovador mecanismo de encendido facilita su uso incluso cuando se utilizan guantes además de que al ser un mecanismo de "no-contacto", reduce la necesidad de repararlo ahorrando tiempo y dinero. La linterna LED Ex-PL30 está disponible tanto en su versión intrínsecamente segura para su uso en la zona EX 0/20 como también en una versión para su uso fuera de las zonas EX.

The MasterEx Lite PL 30 LED torch gives unrivalled high performance.

The 3-watt LED unit is powered by 3 x LR14 batteries, providing many hours of use. With a high IP65 protector rating, the anti-static polymer housing of the unit is ergonomically designed to be comfortably and securely held - even in the most difficult conditions. Switching on the torch could not be easier - simply twist the 'ring-switch'. This Innovative switch mechanism means that even when wearing gloves the user can easily operate the torch and because it is a 'non-contact' mechanism the need for repair is reduced - saving time and money. The LED torch Ex-PL 30* is available as an intrinsically safe version for use in Ex-zone 0/20 and also in a rugged version for use in the non-Ex area.

La lampe LED MasterEx Lite PL 30 offre des prestations sans égal

Le LED de 3 watts est alimenté par 3 piles LRI4 qui lui confèrent beaucoup d'heures d'autonomie. Avec un très bon ratio de protection: IP 65, sa carcasse en polymère et anti-statique a un profil ergonomique pour une prise sûre et confortable y compris dans les positions les plus difficiles. Allumer la lampe ne peut être plus facile: il suffit de tourner la tête. Ce mécanisme d'allumage innovateur permet son utilisation avec des gants, étant un mécanisme de non-contact, il réduit les réparations tout en économisant du temps et de l'argent. La lampe LED Ex-PL30 est disponible tant dans la version intrinsèquement sécuritaire pour l'utilisation en zone EX 0/20 que dans la version pour une utilisation hors des zones EX.

COD

79507

Especificaciones técnicas / Technical specification / Détails techniques

| | |
|--|----------------------------------|
| Temperatura ambiente Ta / Ambient temperature Ta / Température ambiante Ta | -20°C ... +50°C |
| Fuente de luz / Light source / Source de lumière | x 3-Watt LED |
| Alimentación / Power supply / Alimentation | 3x LR 14 batteries (type-tested) |
| Clase de protección / Protection rating / Catégorie de protection | IP 65 |
| Peso / Weight / Poids | approx. 550g |
| Dimensiones / Dimensions / Dimensions | 55/42 x 220 mm |

La linterna LED de grandes prestaciones MasterEx Lite PL 30 está especialmente diseñada para resistir en ambientes industriales a un uso diario y gracias a su nuevo mecanismo de encendido basado en el giro de su cabeza, esta operación se hace de forma rápida y fácil.

- Zona Ex 0 / 20
- 1 x LED gran resistencia (3 vatios)
- 4000 Lux
- Carcasa robusta
- Gran ratio de protección: IP 65

Datos Ex:

Denominación Ex:
Ex II 1G EEx ia IIC T4
Ex II 1D T130°C IP65

EC-Certificado de conformidad:
ZELM 05 ATEX 0272 X

Equipamiento estándar:

- Linterna
- Pilas

Accesorios:

- Pilas de repuesto (cod. 79539)

The MasterEx Lite PL 30 LED high performance torch is especially designed to withstand daily use in industrial environments and with the new 'ring-switch' mechanism, operation is made quickly and easily.

- Ex-zone 0 / 20
- 1 x high performance LED (3-watt)
- 4000 Lux
- Robust housing
- High protection rating of IP 65

Ex-data:

Ex-designation:
Ex II 1G EEx ia IIC T4
Ex II 1D T130°C IP65

EC-Certificate of conformity:
ZELM 05 ATEX 0272 X

Standard delivery:

- Torch
- Batteries

Accessories:

- Spare batteries (cod. 79539)

La lampe LED de grandes prestations MasterEx Lite PL 30 est spécialement conçue pour résister dans l'ambiance industrielle avec une utilisation quotidienne et grâce à son nouveau mécanisme d'allumage basé sur le pivotement de la tête, cette opération se fait rapidement et aisément.

- Zone Ex 0 / 20
- 1 x LED grande résistance (3 watts)
- 4000 Lux
- Carcasse robuste
- Grand ratio de protection: IP 65

Renseignements Ex:

Denomination Ex:
Ex II 1G EEx ia IIC T4
Ex II 1D T130°C IP65

EC-Certificat de conformité:
ZELM 05 ATEX 0272 X

Équipement standart:

- Lampe
- Piles

Accessoires:

- Piles de rechange (cod. 79539)



ILUMINACIÓN / ILLUMINATION / ECLAIRAGE

LINTERNAS INTRÍNSECAMENTE SEGURAS MASTEREX LITE 15, 20, 23 & 25
INTRINSICALLY-SAFE TORCHES MASTEREX LITE 15, 20, 23 & 25
LAMPES INTRINSÈQUEMENT SÛR MASTEREX LITE 15, 20, 23 & 25

MasterEX LITE 25

COD

79511



MasterEX LITE 23

COD

79510



MasterEX LITE 20

COD

79509



MasterEX LITE 15

COD

79508

MasterEX LITE 15, 20, 23 & 25

El novedoso rango de linternas intrínsecamente seguras - con prácticas características tales como foco láser ajustable, dispositivo anti-giro y bombilla de repuesto integrada. Alojado en una carcasa de metal robusto que junto a unos anillos de goma integrados proporcionan una empuñadura segura en las zonas Ex.

The ultimate range of intrinsically-safe torches - with handy features such as adjustable beam focus, anti-roll device and integrated spare bulb. Housed in a solid metal casing that has integral rubber rings to provide a sure grip in hazardous areas.

La nouvelle gamme de lampes intrinsèquement sécuritaire, avec des caractéristiques pratiques telles que le faisceau laser ajustable, le dispositif anti-pivotant et l'ampoule de rechange intégrée. Logée dans une coque de métal robuste, munie d'anneaux en caoutchouc intégrés, assurent une prise parfaite en zones Ex.

Especificaciones técnicas / Technical specification / Détails techniques

| | MasterEx Lite 25 | MasterEx Lite 23 | MasterEx Lite 20 | MasterEx Lite 15 |
|---|-------------------------|-------------------------|------------------------|------------------------|
| Temperatura ambiente Ta / Ambient temperature Ta Température ambiante Ta | -40°C +40°C | -40°C +40°C | -40°C +40°C | -40°C +40°C |
| Suministro eléctrico / Power supply / Alimentation électrique | 2xLR20 | 2xLR 14 | 3xLR6 | 2xER6 |
| Bombilla / Bulb / Ampoule | AMPERCELL AC2C12DIBB | AMPERCELL AC2C12DIBB | AMPERCELL AC23001BB | AMPERCELL AC26401BB |
| Autonomía / Operating time / Autonomie | 17 h | 9 h | 5 h | 4,5 h |
| Clase de protección / Ingress protection / Type de protection | IP 54 | IP 54 | IP 54 | IP 54 |
| Peso / Weight / Poids | approx 740 g | approx 420 g | approx 152 g | approx 120 g |

MasterEx Lite ...
...carcasa de aluminio antichispa

Datos-Ex:
Denominación Ex:
EX II2 G EEx e ia IIC T4

EC-Certificado de conformidad:
TÜV 99 ATEX 1409

Accesorios:

MasterEx Lite 25

- Estuche de cuero, lentes de repuesto (cod. 79546)
- Bombilla de repuesto tipo AC2C12DIBB (cod. 79547)

MasterEx Lite 23

- Estuche de cuero, lentes de repuesto (cod. 79544)
- Bombilla de repuesto tipo AC2C12D/BB (cod.79545)

MasterEx Lite20

- Estuche de cuero, lentes de repuesto (cod.79542)
- Bombilla de repuesto tipo AC2300/BB (cod.79543)

MasterEx Lite 15

- Estuche de cuero, lentes de repuesto (cod.79540)
- Bombilla de repuesto tipo AC26401BB (cod.79541)

MasterEx Lite ...
...non-sparking aircraft aluminium

Ex-data:
Ex designation:
EX II2 G EEx e ia IIC T4

EC-Certificate of conformity:
TÜV 99 ATEX 1409

Accessories:

MasterEx Lite 25

- Leather carry case, spare lens (cod. 79546)
- Spare bulb type AC2C12DIBB (cod. 79547)

MasterEx Lite 23

- Leather carry case, spare lens (cod. 79544)
- Spare bulb type AC2C12D/BB (cod.79545)

MasterEx Lite20

- Leather carry case, spare lens (cod.79542)
- Spare bulb type AC23001BB (cod.79543)

MasterEx Lite 15

- Leather carry case, spare lens (cod.79540)
- Spare bulb type AC26401BB (cod.79541)

MasterEx Lite ...
...coque alu anti-déflagrant

Renseignements-Ex:
Désignation Ex:
EX II2 G EEx e ia IIC T4

EC-Certificat de conformité:
TÜV 99 ATEX 1409

Accessoires:

MasterEx Lite 25

- Etui en cuir, lentilles de rechange (cod. 79546)
- Ampoule de rechange type AC2C12DIBB (cod. 79547)

MasterEx Lite 23

- Etui en cuir, lentilles de rechange (cod. 79544)
- Ampoule de rechange type AC2C12D/BB (cod.79545)

MasterEx Lite20

- Etui en cuir, lentilles de rechange (cod.79542)
- Ampoule de rechange type AC2300/BB (cod.79543)

MasterEx Lite 15

- Etui de cuir, lentilles de rechange (cod.79540)
- Ampoule de rechange type AC2640/BB (cod.79541)

ILUMINACIÓN / ILLUMINATION / ECLAIRAGE

LINTERNA INTRÍNSECAMENTE SEGURA CON CARCASA DE GOMA MASTEREX LITE HD 10
 INTRINSICALLY-SAFE RUBBER CASED TORCH MASTEREX LITE HD 10
 LAMPE INTRINSÈQUEMENT SÛR AVEC COQUE EN CAOUTCHOUC MASTEREX LITE HD 10

MasterEX LITE HD 10



COD

79512

Linterna diseñada y apropiada para su uso en las zonas Ex.

- Bombilla resistente al golpe
- Carcasa robusta a prueba de golpes
- Práctica cuerda de amarre

Datos-Ex:

Denominación Ex:
Ex II 2G EEx ia Eric T4

EC-Certificado de Conformidad:
TÜV 00 ATEX 1556

Accesorios:

- Estuche de cuero (cod.79548)
- Bombilla de repuesto tipo KPR 102 (cod.79549)

A torch designed and suitable for use in Ex-hazardous areas.

- Shock resistant bulb
- Rugged and shock proof housing
- Practical hand loop

Ex-data:

Ex designation:
Ex II 2G EEx ia Eric T4

EC-Certificate of conformity:
TÜV 00 ATEX 1556

Accessories:

- Leather carry case (cod.79548)
- Spare bulb type KPR 102 (cod.79549)

Lampe dessinée et appropriée pour une utilisation en zone Ex.

- Ampoule résistante aux coups
- Coque robuste à l'épreuve des coups
- Bride pratique de fixation

Renseignements-Ex:

Denomination Ex:
Ex II 2G EEx ia e IIC T4

EC-Certificat de conformité:
TÜV 00 ATEX 1556

Accessoires:

- Etui en cuir (cod.79548)
- Ampoule de rechange type KPR 102 (cod.79549)

Especificaciones técnicas / Technical specification / Détails techniques

| | |
|--|---|
| Temperatura ambiente Ta / Ambient temperature Ta / Température ambiante Ta | -20°C ... +40°C |
| Suministro eléctrico / Power supply / Alimentation électrique | 2 x LR6/AA |
| Bombilla / Bulb / Ampoule | KPR102-Sonca / KPR104-Philips/ 2127 OSRAM |
| Autonomía / Operating time / Autonomie | hasta 3,5h / up to 3,5 h / jusqu'à 3,5 h |
| Clase de protección / Ingress protection / Type de protection | IP 65 |
| Peso / Weight / Poids | approx 200 g |
| Dimensiones / Dimensions / Dimensions | 165x44mm |

EGA Master S.A.
 ART IN INNOVATION



ILUMINACIÓN / ILLUMINATION / ECLAIRAGE

LÁMPARA DE MANO INTRÍNSECAMENTE SEGURA MASTEREX SHL 300
INTRINSICALLY SAFE HANDLAMP TYPE MASTEREX SHL 300
LAMPE À MAIN INTRINSÈQUEMENT SÛR MASTEREX SHL 300

MasterEX SHL 300

La MasterEx SHL 300 es un nuevo tipo de lámpara de mano completamente nuevo certificado para Zonas 0 y 20. Al desarrollar este aparato, el usuario fue el primero en ser considerado –para facilitar su portabilidad y el manejo con una sola mano a la vez que le proporcionase una iluminación excepcionalmente alta.

El especial diseño de la MasterEx SHL 300 la convierte de forma simultánea en altamente ergonómica y funcional. Su mango, su distribución de peso, combinada con una meticulosa colocación de interruptores y displays hacen de ella un aparato óptimo.

Como lámpara LED recargable de mano certificada para su uso en Zona 0 / 20, la MasterEx SHL 300 es verdaderamente única, un producto de clase mundial de fácil portabilidad y segura operabilidad en toda clase de emplazamientos.

Adicionalmente, la MasterEx SHL 300 es también altamente apropiada para su uso por los servicios de extinción de incendios porque cumple los exigentes requisitos de la norma DIN 14642 sobre el equipamiento a llevar por éstos, para las lámparas protegidas de explosiones.

El utilizar 3 potentes LEDs de 3 vatios no solo la convierte en lámpara de mano más brillante de su tipo, sino también a conseguir una fiabilidad operativa excepcionalmente alta. Esto es debido, en parte, a que los LEDs tiene una vida de alrededor de 100.000 horas, pero también, a su "controlador inteligente" que asegura una alta iluminación incluso en el caso de que falle uno de ellos.

Se puede contar con la MasterEx SHL 300 en cualquier situación, porque junto con a su foco se encuentran también integradas las funciones luz de emergencia y luz destellante y los opcionales coloreados filtros difusores – los cuales se encajan fácilmente dentro de la cabeza pivotante.

El cargador está también diseñado para su fácil uso y manejo con una sola mano. No existen mecanismos de cierre para amarrar la lámpara – simplemente insertar el MasterEx SHL 300 dentro del cargador y está seguramente acoplada. El cargador-disponible de red y para el coche- puede sujetarse en ambas posiciones: horizontal y vertical.

La MasterEx SHL 300 es un tipo de iluminación a mano totalmente nuevo certificado para zonas 0 y 20. Los criterios de desarrollo del producto ont été la facilité de port, l'utilisation à une seule main et un éclairage de très haute qualité.

Le dessin spécifique de la MasterEx SHL 300 lui confère une grande ergonomie et fonctionnalité. Son manche, sa répartition du poids, combinés à une bonne disposition des interrupteurs et displays maximisent cette lampe.

Comme la lampe LED elle est rechargeable et certifiée pour son utilisation en zone 0 / 20, la MasterEx SHL 300, elle est unique, de classe mondiale, facile à porter d'une sécurité opérationnelle dans tous les endroits.

De plus, la MasterEx SHL 300 est totalement appropriée pour les services incendie, car elle remplit les conditions exigentes de la norme DIN 14642, concernant l'équipement de protection anti explosions.

De posséder 3 LEDs puissants de 3 watts, non seulement elle a le faisceau le plus brillant des lampes à main, mais elle procure une fiabilité exceptionnellement importante. Ceci est dû, en partie au fait que les LEDs ont une durée de vie de 100.000 heures, mais aussi, à son "contrôle intelligent" qui assure un "Éclairage important".

Même si un Led faillit toutes situations, car conjointement à son faisceau, sont intégrées les fonctions de lumière de secours, anti-éblouissement et les options de filtres diffuseurs colorés se placant facilement sur la tête pivotante.

Le chargeur est aussi conçu pour une utilisation aisée d'une seule main. Il n'existe pas de mécanisme de serrage pour fixer la lampe, uniquement mettre le MasterEx SHL 300 à l'intérieur du chargeur pour qu'elle soit bien connectée. Le chargeur disponible pour secteur ou voiture peut être fixé horizontalement ou verticalement.

The MAsterEx SHL 300 is a completely new type of handheld spotlight certified for Zones 0 and 20. In developing this device, the user was given primary consideration -for ease of carrying and single handed operation whilst providing exceptional high illumination power.

The special design of the MAsterEx SHL 300 means that it is both ergonomic and functional. The handle, the weight distribution ratio, combined with the careful arrangement of switches and displays all go to provide an optimised device.

As a rechargeable LED Handlamp certified for use in Zone 0 / 20, the MAsterEx SHL 300 is truly a unique, world class product that can be easily carried and safely operated in all manner of locations.

Additionally, the MAsterEx SHL 300 is also highly suitable for use by the fire-fighting services as it fulfils the stringent requirements of the fire-fighting equipment standard -DIN 14642 - for explosion-protected Handlamps.

Utilising 3 high-power 3-watt LEDs not only gave rise to the brightest handheld spotlight of its kind, it also achieved an extremely high operational reliability. This is due, in part, to the LEDs having a service life of around 100,000 hours, but also, to the 'intelligent controller' that assures a high illumination power even in the event of single LED failure.

You can depend on the MAsterEx SHL 300 in every situation, because along with the spotlight there is also the integrated emergency and flashing light functions and the optional diffusing and coloured filters – which are fitted easily into the pivoting head.

The charging station is also designed for easy use and single handed operation. There are no locking mechanisms to have to deal with – simply insert the MAsterEx SHL 300 into the charging station and it is securely engaged. The charging station –available for either mains or vehicle operation- can be fixed in place both horizontally and vertically.

ILUMINACIÓN / ILLUMINATION / ECLAIRAGE

MasterEX SHL 300



COD

79513

CHARGING STATION



COD

V

79514

110/230 V AC

79517

12/24 V DC

La MasterEx SHL 300 es una robusta lámpara de mano especialmente diseñada para los entornos industriales y los servicios de extinción de incendios. Certificada para su uso en áreas potencialmente explosivas de zonas 20 y 1 o 20 y 21 de acuerdo con la Directiva 1999/92/EC (ATEX 137), esta linterna de mano dispone de gran número de innovadoras funciones que maximizan su uso y facilitan su empleo.

- Certificada para Zona 0 y 20
- Iluminación de 9000 Lux -generadas por 3 potentes LEDs
- Vida aproximada de los LED 100.000 h
- Carcasa robusta y antiestática Dimensionada para IP 65
- Cabeza oscilante
- Óptima distribución de peso -ergonómico y comfortable transporte
- Display indicador de capacidad de batería (5 sectores)
- Función luz de emergencia con alto brillo
- Modo destelleante

Datos-Ex:

Denominación Ex:
II 1G Ex ia IIC T4
II 1D Ex tD A20 IP65 T108°C
EC-Certificado de conformidad: pendiente

Accesorios:

- Set de coloreados filtros difusores - blanco, rojo, verde y amarillo (cod.79550)
- Cargador de red (cod.79514)
- Cargador para el coche (cod.79517)
- Correa de amarre (cod.79551)

The MAsterEx SHL 300 is a robust Handlamp specifically designed for industrial environments and the firefighting services. Certified for use in potentially explosive areas of Zones 20 and 1 or 20 and 21 in accordance with Directive 1999/92/EC (ATEX 137), this Handlamp boasts a number of innovative functions that maximise the use and ease of operation.

- Zone 0 and 20 certified
- 9000 Lux illumination power - generated by 3 high-power LEDs
- LED service life of approx. 100.000 h
- Robust, anti-static housing -rated to IP 65
- Pivoting head
- Optimum distribution of weight -ergonomic and comfortable to carry
- Battery capacity display (5 section indicator)
- Emergency light function with high brightness
- Flash mode

Ex-Data:

Ex-designation:
II 1G Ex ia IIC T4
II 1D Ex tD A20 IP65 T108°C
EC-Certificate of conformity: pending

Accessories:

- Set of coloured diffusing filters -white, red, green and yellow. (cod.79550)
- Charging station for mains voltage operation (cod.79514)
- Charging station for vehicle / car voltage operation (cod.79517)
- Carrying strap (cod.79551)

La MasterEx SHL 300 est une lampe á main robuste spécialement conçue pour les environnements industriels et les services incendies. Certifiée pour son utilisation dans des aires potentiellement explosives de zones 20 et 1 ou 20 et 21 suivant la directive 1999/92/EC (ATEX 137), cette lampe á main dispose d'un grand nombre de fonctions novatrices qui optimisent son utilisation.

- Certifiée pour les zones 0 et 20
- Eclairage de 9000 Lux - généré par 3 LEDs puissants
- Durée de vie des LED 100.000 h
- Carcasse robuste et anti-statique - Développée en IP 65
- Tête oscillante
- Répartition du poids optimale -ergonomique et de transport aisé
- Display indicateur de batteries (5 secteurs)
- Fonction avec lumière de secours d'une grande brillance
- Mode anti-éblouissement

Renseignements-Ex:

Denomination Ex:
II 1G Ex ia IIC T4
II 1D Ex tD A20 IP65 T108°C
EC-Certificat de conformité en cours

Accessoires:

- Set de filtres diffuseurs colorés - blanc, rouge, vert et jaune (cod.79550)
- Chargeur sur secteur (cod.79514)
- Chargeur de voiture (cod.79517)
- Bride de fixation (cod.79551)

Especificaciones técnicas / Technical specification / Détails techniques

| | |
|--|---|
| Temperatura ambiente Ta / Ambient temperature Ta / Température ambiante Ta | -20 ... +50°C |
| Temperatura de almacenamiento / Storage temperature / Température de stockage | -30 ... +60°C |
| Autonomía con batería cargada / Operating time with charged battery / Autonomie de la batterie chargée | 6h @ 100% on / 12h @ 50% on |
| Dimensiones / Dimensions / Dimensions | 140mm x 190mm x 300mm |
| Peso / Weight / Poids | approx. 2,2kg |
| Clase de protección / IP rating / Type de protection | IP65 |
| Resistencia al disolvente / Solvent resistance / Résistance au dissolvant | Acetona / Acetone / Acétone |
| Protección ESD / ESD protection / Protection ESD | Carcasa antiestática / Anti-static housing Carcasse anti-statique |
| Denominación CE / CE designation / Dénomination CE | CE 0102 |
| Suministro eléctrico / Power supply / Alimentation électrique | Pack de baterías Ex 3.7 V, 11 Ah, min. 500 ciclos de carga sin descarga completa y protección ante cortocircuitos / Ex battery pack 3.7 V, 11 Ah, min. 500 charging cycles with over-discharge and short-circuit protection / Pack de batteries Ex 3.7 V, 11 Ah, min. 500 cycles de charges sans complète décharge et protection anti-coupe circuits |
| Lámpara / lamp / lampe | 3 x 3W LEDs |



ILUMINACIÓN / ILLUMINATION / ECLAIRAGE

LINTERNA DE BOLSILLO LED INTRÍNSECAMENTE SEGURA MASTEREX LITE LED 8
INTRINSICALLY-SAFE LED POCKET TORCH MASTEREX LITE LED 8
LAMPE DE POCHE LED MASTEREX LITE LED 8 INTRINSÈQUEMENT SÛR

COD

79515

MasterEX LITE LED 8

Fácil de usar, compacta y siempre a mano, la linterna de bolsillo MAsterEx Lite LED 8 es ideal para cerrar la gama de iluminación.

Easy to use, compact and always on hand, the MAsterEx Lite LED 8 pocket torch ideal for Glose-range lighting.

Utilisation aisée, compacte et toujours á la main, la lampe de poche MAsterEx Lite LED 8 est ideale pour compléter la gamme d'éclairage.

La linterna de bolsillo MasterEx Lite LED 8 es compacta, sólida y fácil de trabajar con ella, para concluir con la gama de iluminación en zonas Ex, trabaja desde la zona 2 a la 1 de acuerdo con la directiva 1999/92/EC (ATEX 137).

- Duración de la operación > 100 horas
- Carcasa de metal robusto
- La vida útil del LED es superior de 100,000 horas operativas
- Posee un clip de seguridad para prevenir encendidos no intencionados
- Fácil de usar gracias a su pequeño tamaño

Datos EX:

Designación Ex:
Ex II 2 G EEx ia IIC T4
EC-Certificado de Conformidad
TÜV 01 ATEX 1692

Accesorios:

- Recambio de diodo de luz blanca (cod.79552)
- Recambio de batería LR 44 (cod.79553)

The Lite-Ex LED 8 is a compact, robust and easily operated LED pocket torch for Glose range lighting in Ex. hazardous areas of Zones 2 and 1 according to Directive 19991921EC (ATEX 137).

- Operating time > 100 hours
- Robust metal housing
- LED life expectancy up to 100,000 operating hours
- Safety clip prevents unintentional switch-on
- Easy to use thanks to Its small size.

Ex-data:

Ex designation:
Ex II2G EEx ia IIC T4
EC-Certificate of conformity:
TÜV 01 ATEX 692

Accessories:

- Spare white light emitting diode (cod.79552)
- Spare battery LR 44 (cod.79553)

La lampe de poche MasterEx Lite LED 8 est compacte, solide et d'une utilisation simple, pour compléter la gamme de lampes pour zones Ex, elle peut être utilisée de la zone 2 á la 1 suivant la directive 1999/92/EC (ATEX 137).

- Durée d'utilisation > 100 heures
- Carcasse en métal robuste
- La vie du LED est supérieure á 100,000 heures effectives
- Elle est munie d'un clips de sécurité pour éviter les allumages involontaires
- Aisée d'utilisation grâce á sa petite taille

Renseignements EX:

Désignation Ex:
Ex II 2 G EEx ia IIC T4
EC-Certificat de conformité
TÜV 01 ATEX 1692

Accessoires:

- Diodo de rechange lumière blanche (cod.79552)
- Batteries LR 44 (cod.79553)

Especificaciones técnicas / Technical specification / Détails techniques

| | |
|---|--|
| Temperatura ambiente Ta / Ambient temperature Ta / Température ambiante Ta | -20°C ... +50°C |
| Temperatura de almacenamiento / Storage temperature / Température de stockage | -20°C ... +50°C |
| Alimentación de energía / Power supply / Alimentation en énergie | 3 x LR 44 IEC |
| Clase de protección / Ingress protection / Type de protection | IP 54 |
| Peso / Weight / Poids | 35g (con baterías / with batteries / avec batteries) |
| Dimensiones / Dimensions / Dimensions | 66x14 mm (LxØ) |

ILUMINACIÓN / ILLUMINATION / ECLAIRAGE

PUNTERO LÁSER INTRÍSECAMENTE SEGURO MASTEREX POINT 02A
INTRINSICALLY-SAFE LASER-POINTER MASTEREX POINT 02A
POINTE LASER INTRINSÈQUEMENT SÛR MASTEREX POINT 02A

COD

79516

MasterEX POINT 02A

**Condiciones estandar:**

- MasterEx-Point 02A
- Baterías 2 x LRO3 (AAA)

Accesorios:

- Batería de repuesto LRO3 (cod.79554)

Características:

- Sólido metal insertado
- Para zonas de Polvo-Ex 22 y 21
- Láser clase 2
- Ligero
- Con clip de retención

Datos-Ex:

Designación Ex:
EX II 2 G EEx Ia IICT4
EX II 2 D Ex iaD 21 T130°C

ECCertificado de conformidad:
ZELM 03 ATEX 0137

Standard delivery:

- MasterEx-Point 02A
- batteries 2 x LRO3 (AAA)

Accessories:

- Replacement battery LRO3 (cod.79554)

Features:

- Robust metal housing
- Dust-Ex zones 22 and 21
- Laser class 2
- Lightweight
- With retaining clip

Ex-data:

Ex designation:
911 2 G EEx Ia IICT4
911 2 D Ex iaD 21 T130°C

EC-Certificate of conformity:
ZELM 03 ATEX 0137

Conditions standards:

- MasterEx-Point 02A
- Piless 2 x LRO3 (AAA)

Accessoires:

- Pile de recharge LRO3 (cod.79554)

Caractéristiques:

- Métal solide inséré
- Pour des zones de poussières-Ex 22 y 21
- Láser classe 2
- Léger
- Avec un clip de rétention

Renseignements-Ex:

Désignation Ex:
Ex II 2G EEx Ia IIC T4
Ex II 2D Ex ia D 21 T130°C

EC Certificat de conformité:
ZELM 03 ATEX 0137

El puntero de láser MasterEx-Point 02A es un mecanismo manual e ideal para señalar objetos que estén en un área peligrosa. Por ejemplo, partes en movimiento e inaccesibles de una planta o maquinaria, pueden ser identificadas con seguridad durante las inspecciones sin tener que interrumpir el proceso o condicionar al personal. La operación es simple –presionando un botón se produce un punto iluminado brillante, el cual es visible a larga distancia. Por ejemplo, en una tubería: se puede destacar el equipo de una instalación donde haya un objeto que vaya a ser reparado o sustituido. Con un sólido metal insertado, con el tamaño de un lápiz y con un clip de retención, el MAsterEx-Point 02 es fácil de llevar en una camisa o en un bolsillo de pantalón. El punteador laser está certificado también para usarlo en zonas de polvo-Ex como son las zonas 22 y 21. La alimentación de energía se hace con baterías homologadas 2 x LRO3 (AAA).

The MasterEx-Point 02A laser beam pointer is a handy sized device ideal for highlighting objects whilst in an Ex-hazardous area. Inaccessible and moving parts on plant and machinery can be Identified safely during inspections without interruption of the process or endangering personnel. Operation is simple -pressing a button produces a bright illuminated point, which is visible over a long distance. For example, pipework: can be then highlighted to show an installation crew where the object to be replaced or repaired is located. With a robust metal housing in a handy pen size with retaining clip, the MAsterEx-Point 02 is easily carried in a shirt or coat pocket. The laser pointer is also certified for use in dust-Ex areas zoned as 22 and 21. Power is supplied from 2 x LRO3 (AAA) type-approved batteries.

La pointe Laser MasterEx-Point 02A est un mécanisme manuel et idéal pour indiquer des objets qui sont dans une zone dangereuse. Par exemple, des corps en mouvement et inaccessibles d'un plancher ou d'une machine, ils peuvent être identifiés lors d'inspections sans avoir à interrompre le processus ou à conditionner le personnel. L'opération est simple -en appuyant le bouton il se produit un point lumineux brillant qui est visible de loin. Par exemple, on peut détacher l'équipement d'une installation qui doit être réparé ou remplacé. Equipée d'une coque robuste, de la taille d'un crayon et avec un clip de rétention, le MAsterEx-Point 02 peut se porter facilement dans la poche de la chemise ou dans la poche du pantalon. La pointe Laser est aussi certifiée pour l'utilisation dans des zones de poussières-Ex comme les zones 22 et 21. L'alimentation se fait avec deux piles homologuées 2 x LRO3 (AAA).

Especificaciones técnicas / Technical specification / Détails techniques

| | |
|--|--|
| Longitud de onda / Wavelength / Longueur d'onde | 630 - 670nm |
| Salida / Output / Sorti | <1mW |
| Tipo de laser / Laser class / Type de laser | 2 |
| Temperatura ambiente Ta / Ambient temperature Ta / Température ambiante Ta | -10°C ... +40°C |
| Baterías / Batteries / Piles | 2 x LRO3 (AAA) |
| Autonomía / Operating time / Autonomie | aprox. 80h (en continuo / continuous operation / en continu) |
| Peso / Weight / Poids | aprox. 60g (con baterías / with batteries / avec batteries) |
| Dimensiones / Dimensions / Dimensions | 140x 12 mm |





**EXPOSITORES / DISPLAYS / PRESENTOIRS / STÄNDER / EXPOSITORE
DISPLAY STAND**